



S STULLER

Tools, Equipment,  
and Metals  
2017-2018

Tools, Equipment, and Metals  
2017-2018





Tools, Equipment, and Metals  
 Published by Stuller, Inc. ©2017  
 302 Rue Louis XIV  
 Lafayette, LA 70508 USA  
 Phone 337 262 7700  
 Stuller.com

When Stuller was founded in 1970, Matt Stuller set out to satisfy the customer. Today, 47 years later, that same vision holds true.

Stuller has been beside you over the years, growing product lines tailored to your needs and creating more ways to help you succeed. We have an extensive inventory that includes fashion jewelry, bridal jewelry, diamonds, gemstones, mountings, findings, tools, metals, packaging, and displays. You are sure to find everything you need, every time.

















Often, you need more than stylish products. So, we design sales aids for just this purpose. Use Stuller.com to get real-time product information available 24/7. Enhancing your tried and true selling techniques with digital solutions is the new world of doing business.

Your success is our ultimate goal.



## Table of Contents

### IMPORTANT SYMBOLS

-  Safety Glasses
-  Safety Mask
-  Respirator Recommended
-  Proper Ventilation
-  First Aid
-  Eye Wash Station
-  Flammable
-  Recommended RPMs
-  Lift Gate Required
-  Hazardous Shipping
-  Hazardous Shipping Does Not Apply
-  Number of Pieces Sold by Unit
-  Weight
-  Video Available Online
-  Stuller Exclusive Product
-  Tried, Tested & Used by Stuller

- 4 Product Index
- 6 Abrasives
- 42 Adhesives
- 48 Bags and Envelopes
- 52 Batteries
- 60 Beading and Stringing Supplies
- 84 Benches
- 90 Bench Tools
- 104 Brushes
- 114 Burs
- 140 Casting
- 204 Cleaning
- 226 Drills and Punches
- 238 Engraving
- 266 Files
- 280 Flex Shafts
- 294 Gauges and Mandrels
- 308 Gemological Instruments
- 320 Hammers
- 328 Lamps
- 336 Loupes and Magnifiers
- 348 Metals
- 402 Metal Drawing and Forming
- 416 Plating Supplies
- 434 Pliers, Cutters, and Shears
- 464 Polishing
- 512 Safety Supplies
- 520 Saw Blades and Frames
- 526 Scales
- 534 Screwdrivers
- 540 Soldering Supplies and Torches
- 578 Testers
- 588 Tweezers
- 600 Videos and Books
- 606 Watch Tools and Supplies
- 628 Ordering Information
- 632 Conversion Charts
- 635 Numerical Index

2-Part Silicone Kits	176,177
3D Printers	138,139
<b>Acetone</b>	46
Acrylic Polishers	31
Activator	428
Adapters	477
Adhesives	618
Air Compressor Hook-Up Kits	291
Air Compressors	244
Air Flex Polishers	39
Air-Scribe	291
Alcohol	429
Allset Kits	292
Analyzers	53,55,59
AnD Scales	526-528
Annealing Pans	566
Anodes	420
Antiquing Solutions	429
Anvils and Vises	100,101
Aprons	433, 519
<b>Ball Peen Hammers</b>	327
Bands	6-7
Bead Boards	73, 74
Bead Bumpers	70
Bead Cord	61
Bead Tweezers	82
Beading Kits	75
Beading	97
Beakers	420
Bench Blocks	100
Bench Jewelers	600
Bench Knives	611,612
Bench Microscopes	245,246
Bench Pins	92,93
Bench Stones	265
Benches	84-87
BenchMate Systems	91
Bending and Forming Pliers	444,448
Bezel Stock	371
Binding Wire	577
Bracelet Mandrels	294,303,307
Brass Hammers	325
Broach Files	278
Buff and Rouge Kits	486,488
Bufs	487-493
Bur Holders	130,135,137-139
Busch Bur Kits and Individuals	114-120
<b>Caddy Kits</b>	550
Calipers	302
Carbon Treatment Kits	427
Carving Wax	156,157,159,160,166,167
Case Closers	606,608-610
Case Openers	607-611
Casting Alloy	359,360
Casting Machines	142-144,146-149
Casting Torches	190, 552,553
Casting	601
Center Punches	237
Ceramic Polishers	25
Ceramic	430
Chairs	89
Chasing Hammers	324
Chasing Tools	96
Check Valves and Arrestors	559
Chelsea Filter	316

<b>Citizen Scales</b>	529
Clamps	92-94
Cleaning Solutions	215-220
Cobalt Twist Drills	230,233
Computerized Engraving	240
Conditioner	511
Controllers	153
Copola Sets	408
Copper Tongs	598
Corrosion-Free Bags and Strips	49
Cotter Pin, Bracelet Pin and EZ Change Kits	626,627
Crimp Beads	69,70
Crimp Tubes	69
Cross-Locking Tweezers	596,597
Crucibles	191-193
Crystal Compounds	619
Curing Lamps	149
Cut-Off Discs	21,22
Cutters	80, 81
CZ Color Set	314
<b>Dapping Tools</b>	407-410
Desk Lamps	329,330,333
Diamond Blades	523
Diamond Burs and Discs	132,133
Diamond-Coated Drills	235
Diamond Files	279
Diamond Impregnated Stones	23,35
Diamond Scales	526,527,529
Diamond Sieves	306
Display Rings	317
Dividers	170, 305,306
Double and Single	464-468,470,472
Polishing Units	
Draw Traps	224
Draw Tools	405,406
Dumont Tweezers	591
Dust Collection Units	467,468,471,473
<b>Ear Plugs</b>	516
Electro Cleaner	428
Electro Melts	145,154
Embossing Hammers	324
End Brushes	106
End Caps	70
Engraving Block Accessories	249,250
Engraving Blocks	247,248
Engraving	603
Epoxy	43-45
Eye Wash Stations	519
<b>Felt Buffs</b>	495-497
Felt Wheels	494
File Cleaner	269
File Handles	279
File Sets	272,273,277-279
Finger Protection	502
Flap Wheels	38-40
Flasks	187
Flat Blades	520-523
Flat Sizing Stock	369
Flux and Flux Bottles	570-573
Flux Brushes	111
Flux	195
Flywheels	134
Foredom Motor Kits	280-284
Foredom Motor Parts and Hangers	285-287

<b>Forming Blocks</b>	410
Fret Hammers and Anvils	320-323
Furnaces	151,152
<b>Gaskets</b>	620,621
Gem Polishers	36
Gem Setting	545,463
Gemological	604
GemOro Microscopes	309
GemOro Scales	527,530,531
GIA Microscopes	308
Gloves	432, 501, 517, 518
Gold Polishers	26-37
Gold Scales	528-533
Grading Light	315
Grain	354-358
Graver Handles	256,257
Graver Lube	265
Gravers	258-262
Green-Line Bags	49
Grobet Motor Kits	284
<b>Hand Cleaners</b>	220
Hand Files	270-279
Handpieces	288-291
Hearing Aid Batteries	57
Holders and Baskets	222,223
Hole-Punch Pliers	456
Hoods	418
Hoses	557,558
Hot Plates	419
Hydro Flux Welders	544,545
<b>Ideal-Tek Pliers</b>	440,441
Ideal-Tek Tweezers	588-590
Individual Screwdrivers	534-538
Ingot Molds	194
Injection Wax	184,185
Inox Tweezers	589,593
Inside-Ring Burs	135
Inside-Ring Polisher	26,30,34,35
Investment Scales	200
Investment	196-199
<b>Jewelry Cleaners</b>	224,225
Jewelry Making	600
Jewelry Marking	411-413
Job Envelopes	51
<b>Knives, Scrapers, and Burnishers</b>	95,96
Knotter	75
<b>Lacquer Solutions</b>	429
Lap Machines	478,480
Lap Wheels	479
Laser Engraving	238,239
Laser Welder Accessories	541
Laser Welders	540,541
Lathes	469,472,474,475
LED Lamps	315, 329-331, 333
Lifters and Pushers	94
Light Boxes	334,335
Lighted Loupes	339,341
Lindstrom Pliers	434,435
Lint Tissues	625
Liquid Compound	505
Loupe Cords	339
Lubricants	228,237, 620
<b>Machine Engraving</b>	241

<b>Magnification Lamps</b>	330,332
Magnifier Glasses	345-347
Magnifiers	340-342
Mallets	326
Mandrels	8,19,24,25,34,37, 158, 477
Mats	74
Matt Wax Tools	158,159
Media Blasters	202,203
Metal Testers	584-587
Metals	601
Micro Motors	280,281
Milgrain Tools	98
Milling Wax	155,160
Mixing Bowls	200
Mold Frames	178
Mold Rubber	174-176
Motors Only	283
Mounted Bristle Brushes	104,105,107,108
Mounted Silicone Wheels	27,28
Movement Trays	624
Multipurpose Brushes	112,113
Multipurpose Sets	538
MX Polishers	38
<b>Needles</b>	63
Non-Magnetic Tweezers	589-591
Nylon Hammers	325
<b>Oilers, Blowers, and Brushes</b>	620,623
Opening Pliers	454,455
Optical Screws	622
<b>Pads</b>	16,17, 59
Panther Bur Kits and Individuals	121-131
Paper	13-16
Parallel Pliers	462
Parts Holder	624,625
Parts	59
Pattern Wire	377
Pearl and Beading Tweezers	595
Pearl Drilling Machine	229
Pearl Holders and Drills	229
Pearls	605
Pen Plating Systems	422,423
Pen Vises	236
Pickle and Pickle Pots	574
Pin Removal Tools	614-616
Planishing Hammers	327
Plastic Tweezers	590
Plates	406
Plating Kits	416,417
Plating Racks	421
Plating Solutions	424-426
Plating Wire	421
Platinum Polishers	19,33,35
Pliers Kits	442,446,452,453
Pliers	80,83
Polariscope and Dichroscope	313
Polishing Clothes	500,501
Polishing Media	511
Polishing Unit Accessories	466,467,469
Post Protectors	427
Power Gravers	242
Practice Rings and Sheet	241
Preform Kits	227
Pulse Welders	542,543
Pumice Polishers	36,37

<b>Punches</b>	410
<b>Raising Hammers</b>	323
Reamers	79
Rechargeable Batteries	57,58
Rectifiers	419
Red Sable	111
Red-Line Bags	48
Regulators	560-562
Respirators	512,513
Revere Pliers	442
Ring Cracker	516
Ring Cutters	457
Ring Finger Gauges	295,298,299,
Ring Mandrels	294-297
Ring Stretchers	414,415
Rolling Mills	402-405
Rolls	8
Rouge	481-486
Rubber Polishers	20,30,33,34
Rulers	304
<b>Safety Glasses</b>	514-516
Satin Finish Wheels	498,499
Saw Blades	520-523
Saw Frames	524
Scratch Brushes	112
Screwdriver Sets	534-539, 622
Scribes and Tracers	253
Scrimps	68
Setting	602
Sharpeners	263, 539
Sharpening Systems	254
Shears and Scissors	80, 81, 457,463
Sheet	361-363
Shellac and Holders	251,252
Shells	9
Silk Cord	60
Skin Protection	516
Sliding Gauges	302
Slim-Line Pliers	443,453
Snap-On Discs	22-24
Solder Chemical Shields	575
Solder Fume Systems	548
Solder Picks	569
Solder Tweezers	596-598
Solder	378-383
Soldering Pads	564,567-569
Specialty Pliers	454,455,457
Spectroscope	313
Spindle Adapters	110
Spindles	475,476
Spiral Blades	523
Spiral Maker	65
Split Ring Tweezers	594
Sponges	16
Spring Bar Tools	625
Sprue Base	188
Sprue Cutters	450,451
Sprue Wax	186
Stampings	384-400
Standard Batteries	56,57
Stands	405
Steam Tweezers	221,222, 598,599
Steamer Additives	216
Steamers	204-208

<b>Steel Shot</b>	511
Sticks	10,12
Stirring Rods	154
Stone Gauges	300,301,304
Stone Papers and Sorting Trays	317
Stone Testers	578-583
Stringing Glue	44
Strip	363
Stuller Pliers	445
Super Glue	42,43
<b>Tanita Scale</b>	527
Tap and Die Sets	411
Test Kits	427
Thank You Envelopes	51
Thermometer	421
Third Hands	564
Thread Burner	76
Titanium Polishers	35
Titanium	231,232
Tool Holders	88
Torch Kits	550-552
Torch Lighters	563
Torch Stands	563
Torch Tips	553,555-557
Triangle Sizing Stock	370
Triplet Loupes	336-339
Tronex Pliers	435-438
Tube Cutters	525
Tubeing	374,375
Tumblers	503, 508
Tungsten Carbide Twist Drills	234
Tweezers	565
Twist Wire	376
<b>U-Namel</b>	431
Ultrasonic Racks	223
Ultrasonic	209-215
Unitized Wheels	17
Unmounted Bristle Brushes	104,105,108
Unmounted Silicone Wheels	26,28,29,36
Utility Boxes	76- 78
Utility Tweezers	594,596
<b>Vacuum Pumps</b>	150
Visors	343,344
<b>Watch and Jewelry Forms</b>	51
Watch Batteries	53-55
Watch Battery Kits	52,54
Watch Cleaning Solutions	618
Watch Hand Removal Tools	617
Watch Repair	603
Wax Burs	135
Wax Files	267
Wax Solvent	173
Wax Templates	161
Wax Wire	163-165
Waxer	170-172
Weights	533
Welding tanks	562
Wire Guardian	69
Wire	63-67, 364-366
Wolf Wax Tools	162,202
Wood Hub Brushes	106,107,109
Write-On Bags	50,51
<b>Xuron Pliers</b>	458,459

All items are priced at jeweler's cost, are sold each, unless otherwise noted, and are subject to change without notice. Visit Stuller.com for our complete product selections, current pricing, and quantity price breaks. | 5



# ABRASIVES

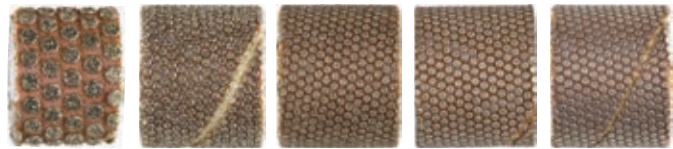

### FLEX DIAMOND BANDS

Excellent for inside ring cleaning, shaping, and carving. They can be used wet or dry on both metals and stones. Cuts sanding time in half. These bands should be used on the expanding drum mandrels: 43-1262 or 43-1266.



**Order # 10-11000** Length 1/2" OD 1/2"

Grit	60	120	200	400	800
12+	\$5.66	\$5.66	\$5.66	\$5.66	\$5.66
6+	\$5.90	\$5.90	\$5.90	\$5.90	\$5.90
1+	\$6.15	\$6.15	\$6.15	\$6.15	\$6.15



### CUBITRON CERAMIC ABRASIVE

These purple bands are coated with a ceramic aluminum-oxide mineral, which is very aggressive and the toughest on the market. They provide longer life, great finish, and dust control all wrapped into one.



**Order # 10-11001** Length 1/2" OD 1/2"

Grit	80	120	220
12+	\$13.71	\$13.71	\$13.71
6+	\$14.30	\$14.30	\$14.30
1+	\$14.90	\$14.90	\$14.90

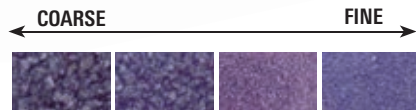

**Kit Order # 10-6000** 12+ \$26.27  
42-Piece Assortment with Mandrel 6+ \$27.81  
1+ \$30.90



### DIAMOND MICRO-FINISHING POLISHING BANDS

The Diamond Micro bands are designed to improve productivity and reduce the cost of finishing. Durable yet flexible due to its unique film design.

**Order # 10-11002** Length 1/2"

Grit	220	320	400	600
12+	\$2.88	\$2.88	\$2.88	\$2.88
6+	\$3.24	\$3.24	\$3.24	\$3.24
1+	\$3.60	\$3.60	\$3.60	\$3.60

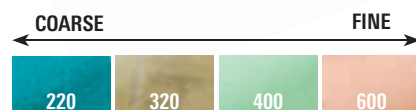

**Kit Order # 10-8420** 12+ \$44.30  
21-Piece Assortment with Mandrel (5 of each grit) 6+ \$46.22  
1+ \$48.15

### SILICON CARBIDE SANDING BANDS

Excellent for miniature sanding. These high-quality bands outlast most other silicon carbide abrasive bands on the market and use special rubber, expanding-head mandrels.



**Order # 10-11003** Length 1/2"

Grit	80	120	180	240	320	120	180
OD	1/2"	1/2"	1/2"	1/2"	1/2"	1/2"	1/4"
12+	\$7.91	\$7.91	\$7.91	\$7.91	\$7.91	\$7.91	\$7.91
6+	\$8.26	\$8.26	\$8.26	\$8.26	\$8.26	\$8.26	\$8.26
1+	\$8.60	\$8.60	\$8.60	\$8.60	\$8.60	\$8.60	\$8.60

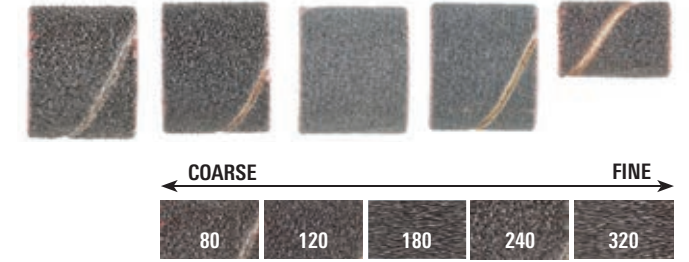

### ALUMINUM OXIDE SANDING BANDS

Aluminum oxide sanding bands provide a fast and smooth cut rate and can be used for clean up and pre-polish work. These sanding bands are durable and last longer than most other bands.

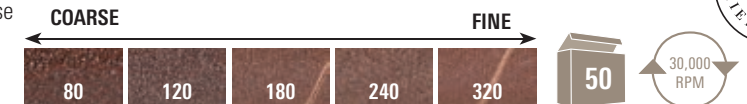

**Order # 10-11004**

Grit	80	120	180	240	320	80	120	180	240	320	80	120	180	240	320	80	120	240
OD	1/2"	1/2"	1/2"	1/2"	1/2"	1/2"	1/2"	1/2"	1/2"	1/2"	1/4"	1/4"	1/4"	1/4"	1/4"	3/8"	3/8"	3/8"
Length	1"	1"	1"	1"	1"	1/2"	1/2"	1/2"	1/2"	1/2"	1/2"	1/2"	1/2"	1/2"	1/2"	1/2"	1/2"	1/2"
12+	\$8.23	\$8.23	\$8.23	\$8.23	\$8.23	\$8.33	\$8.33	\$8.33	\$8.33	\$8.33	\$8.33	\$8.23	\$8.33	\$8.33	\$8.33	\$8.23	\$8.23	\$8.33
6+	\$8.59	\$8.59	\$8.59	\$8.59	\$8.59	\$8.69	\$8.69	\$8.69	\$8.69	\$8.69	\$8.59	\$8.59	\$8.59	\$8.59	\$8.69	\$8.69	\$8.69	\$8.69
1+	\$8.95	\$8.95	\$8.95	\$8.95	\$8.95	\$9.05	\$9.05	\$9.05	\$9.05	\$9.05	\$9.05	\$9.05	\$9.05	\$9.05	\$9.05	\$9.05	\$9.05	\$9.05



### DRUM ARBORS FOR ABRASIVE BANDS

Solid rubber drums mounted on steel arbors expand to hold abrasive bands snugly. The cushioned drum allows the abrasive band to leave an even cut and a smooth finish.



**Order # 10-11005**

OD	1/2"	1/2"	1/2"	1/2"	1/2"	1/2"	1"
Length	1/4"	3/8"	1/2"	1/4"	3/8"	1/2"	1/2"
Shank	3/32"	3/32"	3/32"	1/8"	1/8"	1/8"	1/8"
12+	\$2.02	\$2.12	\$2.12	\$2.12	\$2.12	\$2.25	\$4.19
6+	\$2.11	\$2.21	\$2.21	\$2.21	\$2.21	\$2.35	\$4.37
1+	\$2.20	\$2.30	\$2.30	\$2.30	\$2.30	\$2.45	\$4.55



### RUBBER SANDING DRUM MANDRELS

Solid drum mandrels expand to hold abrasive bands tightly.



**Order # 10-11006**

OD	1/4"	3/8"	1/2"	1/4"	3/8"	1/2"	1/2"
Length	1/2"	1/2"	1/2"	1/2"	1/2"	1/2"	1/2"
Shank	3/32"	3/32"	3/32"	1/8"	1/8"	1/8"	1/8"
12+	\$4.29	\$3.87	\$3.87	\$3.87	\$3.87	\$3.87	\$7.31
6+	\$4.55	\$4.10	\$4.10	\$4.10	\$4.10	\$4.10	\$7.63
1+	\$5.05	\$4.55	\$4.55	\$4.55	\$4.55	\$4.55	\$7.95

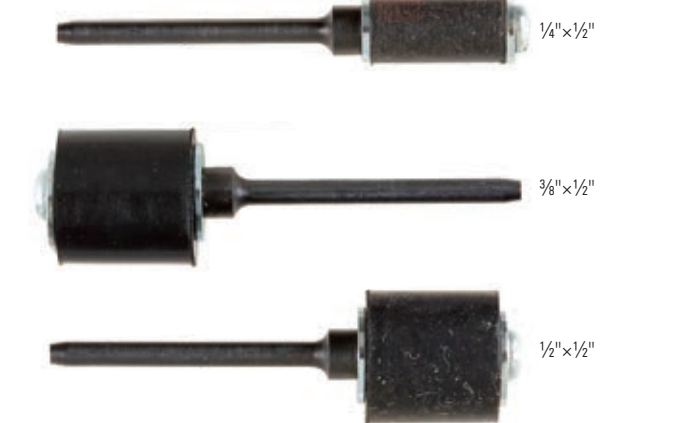

### Left hand threaded for running in reverse operation

Order #	OD x Length	Shank	12+	6+	1+
43-1279	1/2" x 1/2"	3/32"	\$7.31	\$7.63	\$7.95





### 3M® ALUMINUM OXIDE CARTRIDGE ROLLS

Achieve consistent, uniform surface finishes with these aluminum oxide, abrasive paper rolls. Simply cut away the used abrasive material to expose a new sanding surface. Rolls are conveniently mounted on a 3/32" mandrel.

10

Order #	Grit	OD x Length	12+	6+	1+
10-6090	240	1/2" x 1.25"	\$6.12	\$6.48	\$7.20
10-6091	320	1/2" x 1.25"	\$6.12	\$6.48	\$7.20
10-6092	400	1/2" x 1.25"	\$6.12	\$6.48	\$7.20
10-6093	600	1/2" x 1.25"	\$6.12	\$6.48	\$7.20
10-6094	800	1/2" x 1.25"	\$6.12	\$6.48	\$7.20
10-6095	1000	1/2" x 1.25"	\$5.95	\$6.30	\$7.00



### 3M® ALUMINUM-OXIDE CARTRIDGE ROLLS

These cartridge rolls, available in regular and full tapered, provide an economical way of sanding. Layers of the cartridge roll break down, exposing a new sanding surface while sanding.

50

Order #	Grit	OD x Length	12+	6+	1+
10-8122	80	1/2" x 3/4"	\$13.62	\$14.21	\$14.80
10-8123	120	1/2" x 3/4"	\$13.75	\$14.35	\$14.95
10-8124	180	1/2" x 3/4"	\$13.75	\$14.35	\$14.95
10-8125	240	1/2" x 3/4"	\$13.75	\$14.35	\$14.95
10-8126	320	1/2" x 3/4"	\$13.75	\$14.35	\$14.95
10-8151	60	1/2" x 1"	\$15.78	\$16.46	\$17.15
10-8152	80	1/2" x 1"	\$15.78	\$16.46	\$17.15
10-8153	120	1/2" x 1"	\$15.78	\$16.46	\$17.15
10-8155	180	1/2" x 1"	\$15.78	\$16.46	\$17.15
10-8131	240	1/2" x 1"	\$15.69	\$16.37	\$17.05
10-8132	320	1/2" x 1"	\$15.69	\$16.37	\$17.05

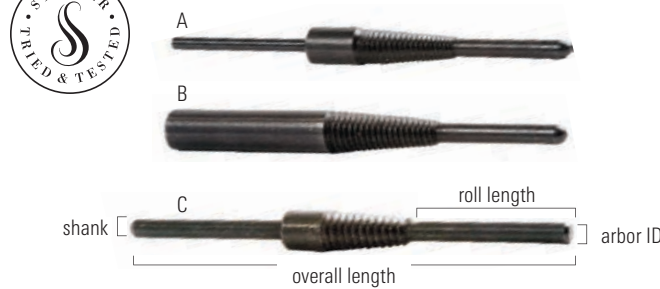

### MANDRELS FOR CARTRIDGE ROLLS

Specially made mandrel accommodates abrasive cartridge rolls.

Item	Order #	Arbor ID	Roll Length	Arbor Length	Shank	12+	6+	1+
A	11-2205	1/8"	2 3/4"	1 1/2"	1/8"	\$3.22	\$3.36	\$3.50
B	11-2204	1/8"	2 1/2"	1 1/2"	1/4"	\$3.22	\$3.36	\$3.50
C	11-2203	1/8"	2 3/4"	1 1/2"	3/32"	\$3.22	\$3.36	\$3.50

### SANDING MANDRELS

Developed by Kate Wolf for sanding and finishing the inside of rings, these stainless steel mandrels are machined true and come with rubber bands to hold the emery paper in place.

Order #	OD x Length	Shank Size	Assortment Quantity	12+	6+	1+
21-0498	—	5/8"	Set of 3	\$8.59	\$9.09	\$10.10
21-0452	3mm x 1/4"	5/8"	Each	\$2.47	\$2.61	\$2.90
21-0003	4mm x 1/2"	5/8"	Each	\$3.78	\$4.01	\$4.45

10,000 RPM

### INSIDE RING SHELLS (EMERY PAPER OR CLOTH)

Drilled for a tapered spindle, these inside ring shells are used to polish and smooth ring insides. Fits over wood mandrel.

12

Order # 10-11007

Grade	Material	12+	6+	1+
4/0 (Finest)	Paper	\$16.28	\$16.99	\$17.70
3/0	Paper	\$16.28	\$16.99	\$17.70
2/0	Paper	\$16.28	\$16.99	\$17.70
1/0	Paper	\$16.28	\$16.99	\$17.70
1	Paper	\$16.28	\$16.99	\$17.70
2	Paper	\$16.28	\$16.99	\$17.70
3 (Coarsest)	Paper	\$16.28	\$16.99	\$17.70
4/0	Cloth	\$14.86	\$15.50	\$16.15
2/0	Cloth	\$14.86	\$15.50	\$16.15
1	Cloth	\$14.86	\$15.50	\$16.15
3	Cloth	\$14.86	\$15.50	\$16.15



### EMERY SHELL KIT

This kit features assorted grits with a wooden cone mandrel. Grits are 4/0, 3/0, 2/0, 1/0, 1, and 2.

Order #	Description	12+	6+	1+
11-3110	Emery Shell Kit (pack of 6)	\$5.57	\$6.36	\$7.95



### WOOD ARBOR

A. Can be used as a 6" polishing stick once coated with adhesive and rolled in abrasive. Arbor hole measures 1/4" for tapered spindle mounting. Made of birch wood.

### WOOD MANDREL

B. Use with emery shells that are held by friction or as a holder for rings, chains, and other items when polishing.

### SPLIT WOOD MANDREL-SPINDLE

C. Insert into the slot of the wood mandrel to create an emery flat wheel. Mandrel fits any tapered shaft. Made of birch wood.

Item	Order #	Description	OD	Length	12+	6+	1+
A	11-2660	Wood Arbor	1/4"	7"	\$1.70	\$1.78	\$1.85
B	11-3330	Wood Mandrel	1/8"	4"	\$1.06	\$1.10	\$1.15
C	11-3060	Split Wood Mandrel	1/8"	4 1/4"	\$1.33	\$1.39	\$1.45

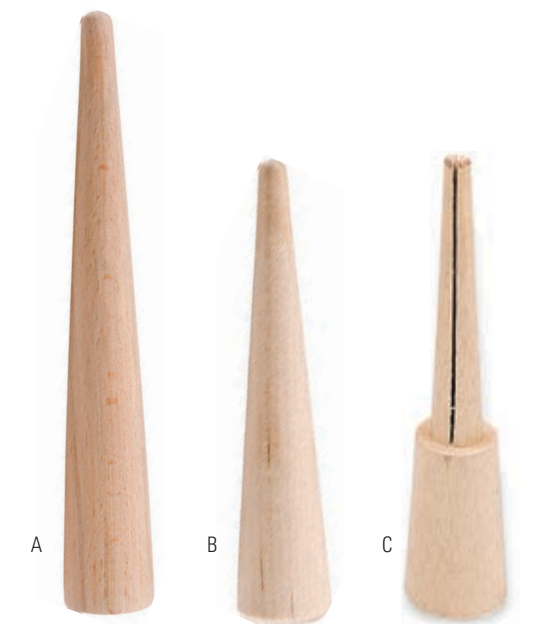



Half-Round - Kit Order # 11-3390



Triangle - Kit Order # 11-3391



Round - Kit Order # 11-3392



**SHAPED SANDING STICKS**

Sanding sticks can be used before you buff or polish a piece to help smooth out deep scratches and surface marring. They can be used to remove corrosion, rust, or other build-up. Many jewelers like them for use on unfired metal clay as well. They are designed so the emery paper is glued to wooden handles to make them easy to hold and easy to use. The wooden handles measure 9/4" and are approximately 7/16" diameter. These emery sanding sticks come in three different grits running from 2/0 (finest) to 3 (coarsest) and three different shapes with so many uses. Sets of three also available. Set pricing not shown.

**Order # 10-11008**

Item	Grit	Grade	12+	6+	1+
A	180	3 (Coarse)	\$2.14	\$2.44	\$3.05
	280	0 (Medium)	\$2.14	\$2.44	\$3.05
	1000	2/0 (Fine)	\$2.14	\$2.44	\$3.05
B	180	3 (Coarse)	\$2.14	\$2.44	\$3.05
	280	0 (Medium)	\$2.14	\$2.44	\$3.05
	1000	2/0 (Fine)	\$2.14	\$2.44	\$3.05
C	180	3 (Coarse)	\$2.59	\$2.75	\$3.05
	280	0 (Medium)	\$2.59	\$2.75	\$3.05
	1000	2/0 (Fine)	\$2.59	\$2.75	\$3.05

**SANDING STICKS**

Handy sanding sticks with molded plastic handles. Both sizes sold with 120 (medium) grit cloth-back sandpaper strips (11" long).

Item	Order #	Description	Grit	Width	12+	6+	1+
D	11-3502	Sanding Stick (Set)	120	1/2"	\$8.42	\$8.91	\$9.90
E	11-3503	Sanding Stick (Set)	120	1"	\$8.42	\$8.91	\$9.90
	11-3504	Refill Pack (pack of 10)	120	1/2"	\$5.23	\$5.54	\$6.15
	11-3505	Assorted Refill Pack (2 of each grit)	80, 120, 180, 220, 400	1"	\$5.19	\$5.49	\$6.10
F	11-3500	Sanding Stick: 1 of each	120, 240	1"	\$14.03	\$14.64	\$15.25
	11-3501	Refill Pack: 1 of each	80, 120, 240	1"	\$8.10	\$8.45	\$8.80

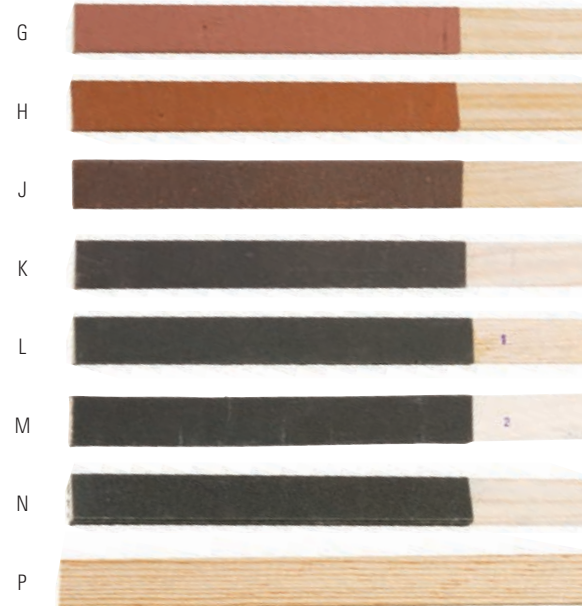

**EMERY STICK**

Emery paper adhered to wood handles for convenient sanding.

**Order # 10-11010**

Item	Grade	WxL	12+	6+	1+
G	4/0	3/4"x9 1/2"	\$0.96	\$1.08	\$1.20
H	3/0	3/4"x9 1/2"	\$0.96	\$1.08	\$1.20
J	2/0	3/4"x9 1/2"	\$0.96	\$1.08	\$1.20
K	0	3/4"x9 1/2"	\$0.96	\$1.08	\$1.20
L	1	3/4"x9 1/2"	\$0.96	\$1.08	\$1.20
M	2	3/4"x9 1/2"	\$0.96	\$1.08	\$1.20
N	3	3/4"x9 1/2"	\$0.96	\$1.08	\$1.20

**Kit Order # 11-3408**

Item	Description	12+	6+	1+
P	Stick Only	\$1.43	\$1.49	\$1.55

**ABRASIVE BOARDS**

Quality abrasive sanding paper is mounted on both sides of this flexible foam board. Ideal for filing, shaping, and smoothing, this file is designed to reach easily into confined areas and in or around contours. Use wet or dry on metal and metal clay.

**Order # 11-3431**

Description	Grit	12+	6+	1+
Red Abrasive Board	400	\$1.64	\$1.85	\$2.05
Green Abrasive Board	800	\$1.64	\$1.85	\$2.05
Blue Abrasive Board	1200	\$1.64	\$1.85	\$2.05
Orange Abrasive Board	2000	\$1.64	\$1.85	\$2.05
Yellow Abrasive Board	2500	\$1.64	\$1.85	\$2.05
White Abrasive Board	3000	\$1.64	\$1.85	\$2.05

**Kit Order # 11-3430**

Description	12+	6+	1+
Abrasive Board Kit (Assorted Colors)	\$7.40	\$8.33	\$9.25

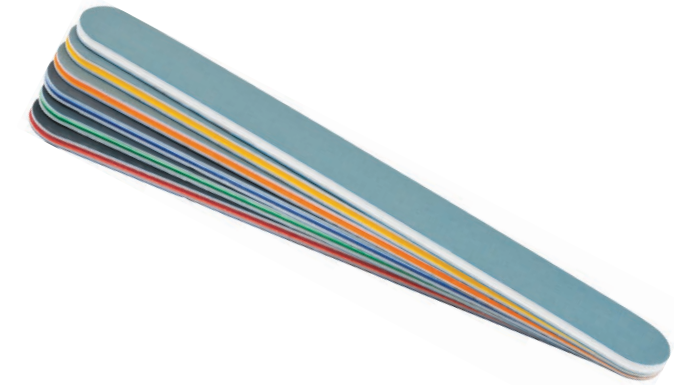

**PRIMO® THREE-STEP POLISHER**

G-TAC three-step polisher consists of 800, 1500, and 4000 grits. The three-step polisher makes quick work on hard to reach places like where head and shanks meet. Also works well on platinum.

Order #	Description	Width	1+
10-8327	3 Step Polisher	6"	\$11.10



**SANDPAPER STICKS**

Provides a fast, easy, and economical way to access detailed, hard-to-reach areas. The 6 1/4" long, tapered, plastic sticks hold a replaceable 1/4" (6.4mm) wide sanding belt. The aluminum-oxide belt is held in place by a patented, spring-loaded mechanism that allows the belt to be rotated 360°, exposing a new sanding surface.

**Order # 10-11009**

Description	Grit	Per Pack	12+	6+	1+
Red Stick	120	Each	\$2.12	\$2.21	\$2.30
Blue Stick	240	Each	\$2.12	\$2.21	\$2.30
Green Stick	320	Each	\$2.12	\$2.21	\$2.30
Yellow Stick	400	Each	\$2.12	\$2.21	\$2.30
Black Stick	600	Each	\$2.12	\$2.21	\$2.30
Belt for Red	120	Pack of 10	\$8.65	\$9.02	\$9.40
Belt for Blue	240	Pack of 10	\$8.65	\$9.02	\$9.40
Belt for Green	320	Pack of 10	\$8.65	\$9.02	\$9.40
Belt for Yellow	400	Pack of 10	\$8.65	\$9.02	\$9.40
Belt for Black	600	Pack of 10	\$7.99	\$8.46	\$9.40







**WATERPROOF ABRASIVE STICK**

High-quality abrasive papers made in Japan. Abrasive papers are pasted five pieces each on both sides of stick. Dispose of each paper one by one after used. Just polish and then dispose it. Available in seven grits from 120-1000 for wide range of polishing steps.

**Order # 11-3506**

Item	Grit	WxL	12+	6+	1+
A	120	3/4"x10"	\$5.57	\$5.81	\$6.05
B	240	3/4"x10"	\$5.57	\$5.81	\$6.05
C	320	3/4"x10"	\$5.57	\$5.81	\$6.05
D	400	3/4"x10"	\$5.57	\$5.81	\$6.05
E	600	3/4"x10"	\$5.57	\$5.81	\$6.05
F	800	3/4"x10"	\$5.57	\$5.81	\$6.05
G	1000	3/4"x10"	\$5.57	\$5.81	\$6.05



**SAND PAPER HOLDERS**

Just put your abrasive paper around the stick and set. Use for filing inside rings, narrow areas, etc. Two types of surfaces are available: square and round.

**Order # 11-3507**

Item	Shape	12+	6+	1+
H	Round	\$12.97	\$13.54	\$14.10
J	Square	\$12.97	\$13.54	\$14.10



Items sold each, unless noted otherwise.



**UTILITY CLOTH ROLL**

Professional shop rolls feature high-quality, aluminum oxide mineral and bonded cloth backings for long abrasive life. A full, resin-over-resin bond construction gives an aggressive cut while providing improved mineral anchorage. 320 grit suitable for applications of ferrous metals. Use with the mandrels shown on page 32.

**Order # 10-11012**

Grit	WxL	12+	6+	1+
120	1"x50 yards	\$21.85	\$23.13	\$25.70
180	1"x50 yards	\$21.85	\$23.13	\$25.70
240	1"x50 yards	\$21.85	\$23.13	\$25.70
320	1"x50 yards	\$41.40	\$43.20	\$45.00



**3M IMPERIAL ABRASIVE SHEETS**

Abrasive sheets use a special bonding technique that allows more uniform cutting and is highly wear-resistant. These sheets feature a waterproof, resin-over-resin bond that resists heat and holds abrasive particles. All sheets are silicon carbide and can be used wet or dry. Can be used with split wood mandrel 11-3060 or split mandrels for handpieces 11-3008 and 11-3009.

**Order # 10-11013**

Grit	WxL	12+	6+	1+
180	9"x11"	\$1.19	\$1.26	\$1.40
220	9"x11"	\$1.19	\$1.26	\$1.40
280	9"x11"	\$1.19	\$1.26	\$1.40
320	9"x11"	\$1.19	\$1.26	\$1.40
400	9"x11"	\$1.19	\$1.26	\$1.40
600	9"x11"	\$1.19	\$1.26	\$1.40
800	9"x11"	\$2.00	\$2.12	\$2.35
1000	9"x11"	\$2.00	\$2.12	\$2.35
1200	9"x11"	\$2.00	\$2.12	\$2.35
1500	9"x11"	\$2.00	\$2.12	\$2.35
2000	9"x11"	\$2.00	\$2.12	\$2.35
2500	9"x11"	\$2.00	\$2.12	\$2.35

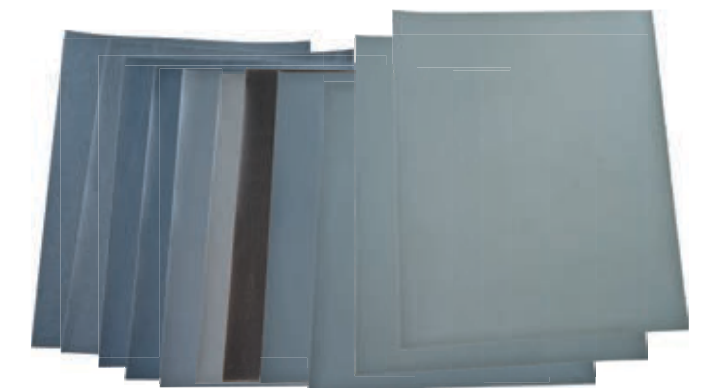

**WATERPROOF EMERY PAPER**

Powerful small particle adhesion provides superior surface finishing. Specially processed micro-grains provide additional cutting surface for fast material removal.

**Order # 10-11011**

Grit	WxL	12+	6+	1+
180	9"x13 3/4"	\$0.88	\$0.99	\$1.10
220	9"x13 3/4"	\$0.88	\$0.99	\$1.10
240	9"x13 3/4"	\$0.88	\$0.99	\$1.10
280	9"x13 3/4"	\$0.88	\$0.99	\$1.10
400	9"x13 3/4"	\$0.88	\$0.99	\$1.10
500	9"x13 3/4"	\$0.88	\$0.99	\$1.10
600	9"x13 3/4"	\$0.88	\$0.99	\$1.10
800	9"x13 3/4"	\$0.88	\$0.99	\$1.10
1000	9"x13 3/4"	\$0.88	\$0.99	\$1.10
1200	9"x13 3/4"	\$0.88	\$0.99	\$1.10

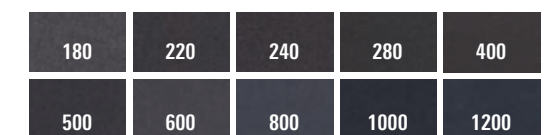

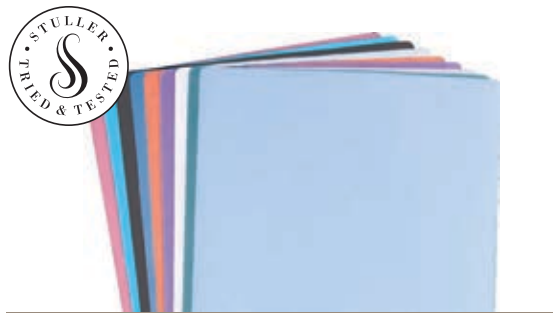

<b>Kit Order # 10-8342</b>	<b>12+</b>	<b>6+</b>	<b>1+</b>
Solid Assortment (10 sheets/box)	\$12.85	\$12.85	\$12.85

**SLURRY COATED POLISHING CLOTH**

Backed by a cotton and rayon material combination, the minerals are micron particles with a unique blend of various types of minerals applied in a slurry coating process. G-Tac slurry coated polishing cloths and strips provide strength and durability provided by a unique backing material which sets them apart from traditional polishing paper, while giving a constant uniform finish. \*Colors may vary.

**Order # 10-8340**

Grit	Color	WxL	12+	6+	1+
360	Dark Gray	4"x7½"	\$11.36	\$11.86	\$12.35
400	Sky Blue	4"x7½"	\$11.36	\$11.86	\$12.35
600	Coral Blue	4"x7½"	\$11.36	\$11.86	\$12.35
800	Egg Shell	4"x7½"	\$11.36	\$11.86	\$12.35
1000	Vibrant Pink	4"x7½"	\$11.36	\$11.86	\$12.35
1200	Dark Blue	4"x7½"	\$11.36	\$11.86	\$12.35
1500	Lavender	4"x7½"	\$11.36	\$11.86	\$12.35
2000	Blue	4"x7½"	\$11.36	\$11.86	\$12.35
4000	Light Blue	4"x7½"	\$11.36	\$11.86	\$12.35



<b>Kit Order # 10-8343</b>	<b>12+</b>	<b>6+</b>	<b>1+</b>
Strip Assortment (120 perforated/box)	\$17.99	\$18.77	\$19.55

**SLURRY COATED POLISHING STRIPS**

Backed by a cotton and rayon material combination, the minerals are micron particles with a unique blend of various types of minerals applied in a slurry coating process. G-Tac slurry coated polishing cloths and strips provide strength and durability provided by a unique backing material which sets them apart from traditional polishing paper, while giving a constant uniform finish. \*Colors may vary.

**Order # 10-8344**

Grit	Color	WxL	12+	6+	1+
360	Black	4"x7"	\$13.25	\$12.72	\$12.19
400	Sky Blue	4"x7"	\$13.25	\$12.72	\$12.19
600	Coral Blue	4"x7"	\$12.95	\$12.43	\$11.19
800	Egg Shell	4"x7"	\$13.25	\$12.72	\$12.19
1000	Vibrant Pink	4"x7"	\$13.25	\$12.72	\$12.19
1200	Dark Blue	4"x7"	\$13.25	\$12.72	\$12.19
1500	Lavender	4"x7"	\$13.25	\$12.72	\$12.19
2000	Blue	4"x7"	\$13.25	\$12.72	\$12.19
4000	Light Blue	4"x7"	\$13.25	\$12.72	\$12.19

**MICRO-POLINET SANDPAPER**

- Micro-Polinet is a very flexible sanding cloth using ultra fine screen-mesh cloth (100 mesh), designed to prevent clogging.
- Both sides are coated with grains.
- Waterproof and oil resistant; can be used for both wet and dry operations.
- Constant sanding ability lasts till the end of its longer life.
- You can cut into any size to meet your purpose.
- Standard size: 210mm x 280mm

**Order # 11-0758**

Grit	Color	Micron	12+	6+	1+
600	Blue	20 µ	\$3.96	\$4.46	\$4.95
800	Yellow	14 µ	\$3.72	\$4.19	\$4.65
1000	Red	11.5 µ	\$3.96	\$4.46	\$4.95
2000	Blue	6.7 µ	\$3.72	\$4.19	\$4.65
3000	Orange	4 µ	\$3.72	\$4.19	\$4.65
4000	Green	3 µ	\$3.72	\$4.19	\$4.65



**EMERY CLOTH**

Traditional cloth sheets provide consistent finish and extra long life. Can be used with split wood mandrel 11-3060 or split mandrels for handpieces 11-3008 and 11-3009.

**Order # 10-11014**

Grit	Grade	WxL	12+	6+	1+
180	Coarse	9"x11"	\$1.23	\$1.31	\$1.45
220-240	Medium	9"x11"	\$1.23	\$1.31	\$1.45
320	Fine	9"x11"	\$1.23	\$1.31	\$1.45



**WET OR DRY POLISHING PAPER**

The nonwoven backing allows easy polishing of interior shapes and contours. Precision, micron grading provides a unique, consistent finish. Can be used with split wood mandrel 11-3060 or split mandrels for handpieces 11-3008 and 11-3009. Kit contains six sheets: one grit each.

**Order # 10-11015**

Grit	Color	Micron	WxL	12+	6+	1+
400	Green	30 µ	8½"x11"	\$1.70	\$1.78	\$1.85
600	Gray	15 µ	8½"x11"	\$1.70	\$1.78	\$1.85
1200	Blue	9 µ	8½"x11"	\$1.70	\$1.78	\$1.85
4000	Pink	3 µ	8½"x11"	\$1.70	\$1.78	\$1.85
6000	Mint Green	2 µ	8½"x11"	\$1.70	\$1.78	\$1.85
8000	Pale Green	1 µ	8½"x11"	\$1.70	\$1.78	\$1.85

**Kit Order # 11-0726**

Kit (6 sheets) 1 each	\$5.57	\$5.81	\$6.05
-----------------------	--------	--------	--------

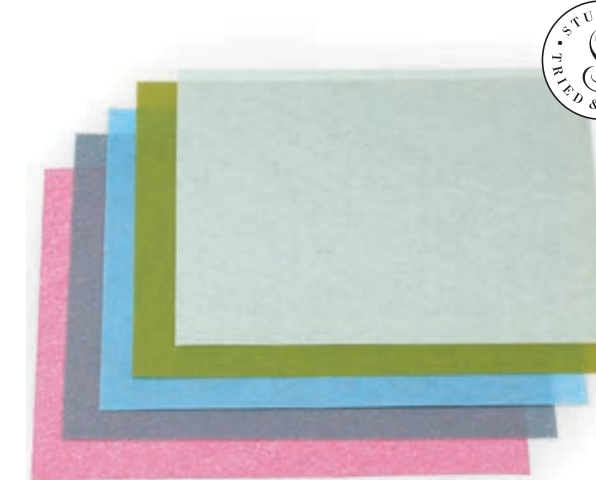

**PLATINUM ABRASIVE PAPER**

Use exclusively for platinum. This abrasive paper is an excellent pre-polish step when working with this precious metal.

**Order # 10-11016**

Grit	Color	Micron	WxL	12+	6+	1+
360	Gray	35 µ	9"x11"	\$1.10	\$1.15	\$1.20
400	Gray	30 µ	9"x11"	\$1.10	\$1.15	\$1.20
500	Gray	20 µ	9"x11"	\$1.10	\$1.15	\$1.20



**MICRO-FINISHING FILM SHEETS**

Use on large surface areas. These special film sheets are micro-graded abrasive, which provides a consistent cut rate and finish. Micro-graded film sheets reduce sanding steps and provide an easy-to-buff finish. Long lasting, these micro-grade films can replace emery papers.

**Order # 10-11017**

Grit	Micron	WxL	12+	6+	1+
220	60 µ	8½"x11"	\$2.07	\$2.16	\$2.25
320	40 µ	8½"x11"	\$2.07	\$2.16	\$2.25
500	20 µ	8½"x11"	\$2.07	\$2.16	\$2.25
600	15 µ	8½"x11"	\$2.07	\$2.16	\$2.25
1200	9 µ	8½"x11"	\$2.07	\$2.16	\$2.25

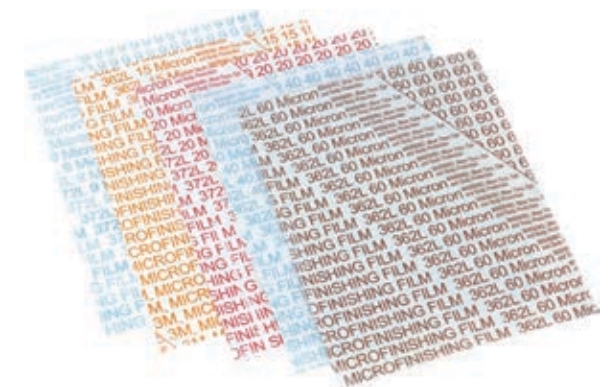



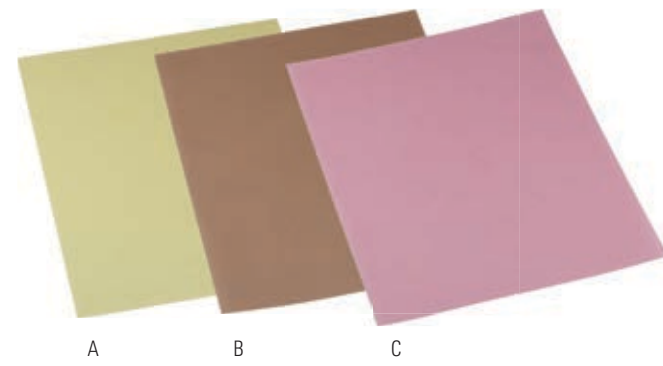

**LAPPING FILM**

Finishing films are designed to reduce the buffing process for platinum and gold. Available in three grits for a three-step finishing process for platinum and a one-step process for gold finishing. The 12 micron (yellow) sheet is used for pre-polish, the five micron (brown) is used to impart a bright finish on platinum, and the three micron (pink) sheet is used to produce an extra bright finish on platinum before the final buffing. For gold, you can use the 12 micron (yellow) sheet, and then go directly to the polishing buff. Use with a 11-3060 split wood mandrel or split mandrels for handpiece 11-3008 and 11-3009.

**Order # 10-11018**

Item	Color	Micron	W×L	12+	6+	1+
A	Yellow	12 μ	8½"×11"	\$1.56	\$1.63	\$1.70
B	Brown	5 μ	8½"×11"	\$1.56	\$1.63	\$1.70
C	Pink	3 μ	8½"×11"	\$1.56	\$1.63	\$1.70

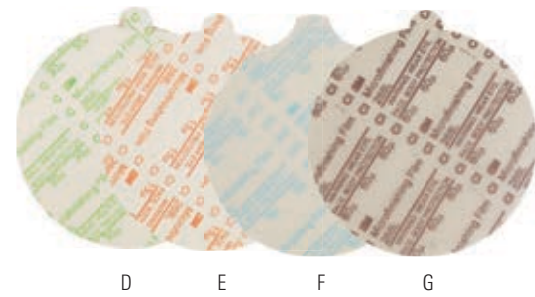

**MICRO-FINISHING DISC**

Superior-graded, aluminum oxide, pressure-sensitive discs that ensure consistent surface finish. Must be used with a 6" aluminum back plate.

**Order # 11-0800**

Item	Micron	OD	12+	6+	1+
D	30 μ	6"	\$1.89	\$2.16	\$2.70
E	15 μ	6"	\$1.89	\$2.16	\$2.70
F	9 μ	6"	\$1.89	\$2.16	\$2.70
G	60 μ	6"	\$1.89	\$2.16	\$2.70



**SANDING SPONGES**

These sanding sponges provide flexibility and will conform to almost any surface and contour. The sponges are coated with a unique slurry that provides a quick, smooth cut in medium and a pre-polish finish in micro-fine. These unique pads can be folded or trimmed to fit in most details and will not gouge surfaces.

**Order # 10-11020**

Item	Grade	W×L	12+	6+	1+
H	Micro Fine	4½"×5½"	\$4.00	\$4.18	\$4.35
J	Ultra-Fine	4½"×5½"	\$4.00	\$4.18	\$4.35
K	Extra Fine	4½"×5½"	\$4.00	\$4.18	\$4.35
L	Fine	4½"×5½"	\$4.00	\$4.18	\$4.35
M	Medium	4½"×5½"	\$2.31	\$2.31	\$2.31
Assorted Set of 5			\$20.88	\$21.79	\$22.70

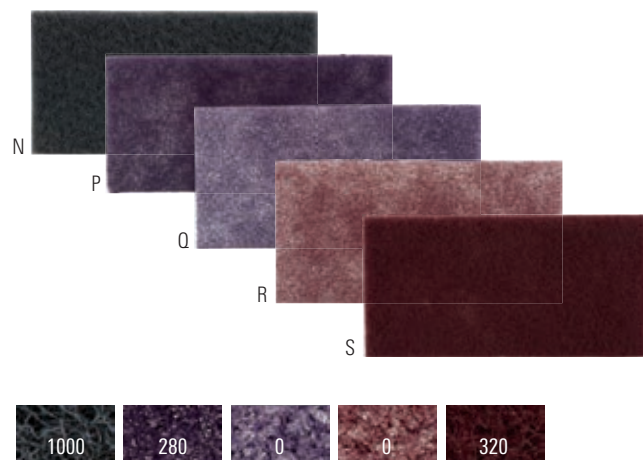

**PRIMO® NON-WOVEN ABRASIVE PADS**

Quality non-hand woven abrasive pad ideal for cleaning, deburring, and creating satin finishes

**Order # 10-8320**

Item	Grit	Color	Type	W×L	12+	6+	1+
N	1000	Gray		5¾"×9"	\$1.61	\$1.68	\$1.75
P	280	Purple		5¾"×9"	\$1.61	\$1.68	\$1.75
Q	0	Light Purple	High Shine	5¾"×9"	\$1.61	\$1.68	\$1.75
R	0	Light Maroon	Ultra High Shine	5¾"×9"	\$1.61	\$1.68	\$1.75
S	320	Maroon		5¾"×9"	\$1.61	\$1.68	\$1.75



**3M HAND PADS**

A.This pad is new to the family of hand-polishing materials. The 96 green pad will provide a smooth, satin finish without leaving scratches.

B.This pad is medium grade and similar to the 7447 pad but has more density and a 30% longer life.

Item	Order #	Grade	W×L	12+	6+	1+
A	<b>10-8164</b>	Satin	6"×9"	\$1.01	\$1.06	\$1.10
B	<b>10-8143</b>	Medium	6"×9"	\$1.75	\$1.82	\$1.90



**3M SCOTCH-BRITE® PADS**

These hand-finished pads have been a standard in the industry for years. These unique pads offer fast, uniform cutting action and are excellent for satin and matte finishes. Pads can also be cut to create your own flap wheel to finish the inside of rings and bracelets.

Item	Order #	Grade	W×L	12+	6+	1+
C	<b>10-8142</b>	Fine	6"×9"	\$1.75	\$1.82	\$1.90
D	<b>10-8140</b>	Coarse	6"×9"	\$3.54	\$3.70	\$3.85
E	<b>10-8141</b>	Medium	6"×9"	\$1.75	\$1.82	\$1.90

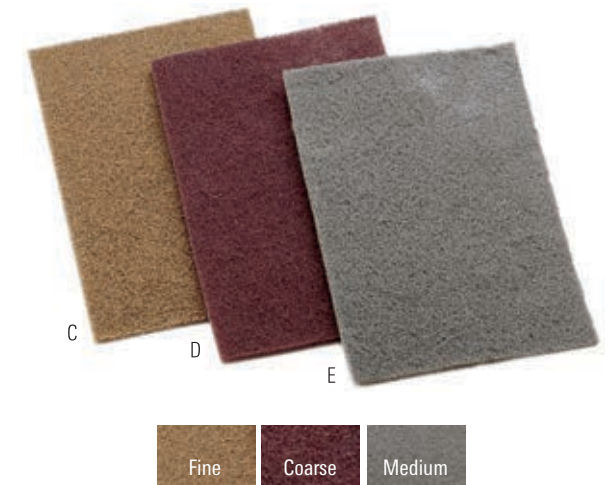

**UNITIZED WHEELS**

Unitized wheels provide a faster cut rate and longer life. Made from a unique construction, they resist loading while providing a smooth-running, chatter-free feeling. Nonwoven technology also allows these wheels to run cool and discourages undercutting and gouging. Unitized wheels are long wearing and have a unique, spring-like action.

**Order # 10-11022**

Item	Grade	OD	Width	Hole ID	12+	6+	1+
F	Coarse	1"	¼"	¼"	\$2.30	\$2.40	\$2.50
G	Medium	1"	¼"	¼"	\$2.30	\$2.40	\$2.50
H	Fine	1"	¼"	¼"	\$2.12	\$2.21	\$2.30
J	Extra Fine	1"	¼"	¼"	\$2.12	\$2.21	\$2.30
K	Coarse	3"	½"	½"	\$12.65	\$13.20	\$13.75
L	Medium	3"	½"	½"	\$12.65	\$13.20	\$13.75
M	Fine	3"	½"	½"	\$11.87	\$12.38	\$12.90
N	Extra Fine	3"	½"	½"	\$11.87	\$12.38	\$12.90

**Extra Mandrels**

<b>43-1283</b>	\$1.48	\$1.67	\$1.85
----------------	--------	--------	--------

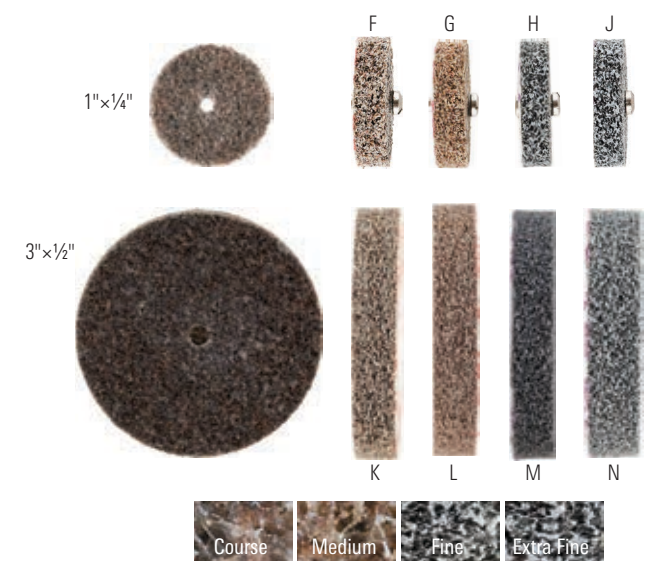





**MOUNTED SATIN FINISH WHEELS**

Mounted on a 3/32" shank.

Order # 10-11021

Item	Grade	OD	Thickness	12+	6+	1+
A	Coarse	7/8"	1/4"	\$1.32	\$1.40	\$1.55
B	Medium	7/8"	1/4"	\$1.32	\$1.40	\$1.55
C	Fine	7/8"	1/4"	\$1.32	\$1.40	\$1.55
D	Luster Bright	7/8"	1/4"	\$1.32	\$1.40	\$1.55



**BRISTLE DISCS**

Kit contains two mandrels (43-1281) and 12 each of the following 9/16" discs: 120, 220, 400, pumice, polish I, and polish II grits.



Item	Order #	Description	12+	6+	1+
A	10-9115	74-Piece, 9/16"	\$58.24	\$60.77	\$63.30

Kit contains two mandrels (43-1282) and 10 each of the following 3/4" discs: 80, 220, 400, and pumice grits.

Item	Order #	Description	12+	6+	1+
B	10-9104	42-Piece Kit, 3/4"	\$36.43	\$38.02	\$39.60

Contains eight each of all sizes and grits along with four mandrels (43-1281). Discs are molded abrasive-filled bristle discs used for deburring, blending, finishing, and polishing.

Item	Order #	Description	12+	6+	1+
C	10-9117	116-Piece Assorted Grits and Sizes	\$88.04	\$91.87	\$95.70



**FLEX TWIST DISC**

EVE Diamond Twists were created specifically for platinum. Each Diamond Twist is imbedded with a diamond formula to ensure an even blend. Diamond Twists are made with the same flexibility as the standard Twists and provide the same high-quality finish.



Order # 11-6527

**GRAY**

OD	Grade	12+	6+	1+
9/16"	Fine	\$0.91	\$0.99	\$1.10
1 1/16"	Fine	\$0.95	\$1.04	\$1.15
1"	Fine	\$1.04	\$1.13	\$1.25



Order # 11-6528

**DARK GRAY**

OD	Grade	12+	6+	1+
9/16"	Medium	\$0.91	\$0.99	\$1.10
1 1/16"	Medium	\$0.95	\$1.04	\$1.15
1"	Medium	\$1.04	\$1.13	\$1.25



Order # 11-6526

**GOLD**

OD	Grade	12+	6+	1+
9/16"	Medium	\$0.91	\$0.99	\$1.10
1 1/16"	Medium	\$0.95	\$1.04	\$1.15
1"	Medium	\$1.04	\$1.13	\$1.25



**SUGGESTED MANDRELS**

Nickel-plated small wheel mandrels.

Mandrel 43-1280	12+	6+	1+
Reinforced Screw Mandrel	\$0.94	\$0.99	\$1.10

**FLEX TWIST DISC**

A new twist developed in Germany for polishing precious and non precious metals. EVE Twist are ideal when used in multiples as a brush or singly as a knife-edge. Extremely Flexible, the new twist action ensures your jewelry receives the ultimate finish.

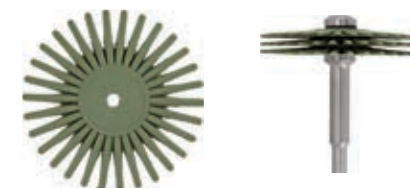

Order # 11-6515

**GREEN**

OD	Grade	12+	6+	1+
9/16"	Extra Fine	\$0.87	\$0.95	\$1.05
1 1/16"	Extra Fine	\$0.95	\$1.04	\$1.15
1"	Extra Fine	\$1.04	\$1.13	\$1.25



Order # 11-6514

**RED/BROWN**

OD	Grade	12+	6+	1+
9/16"	Fine	\$0.87	\$0.95	\$1.05
1 1/16"	Fine	\$0.95	\$1.04	\$1.15
1"	Fine	\$1.04	\$1.13	\$1.25



Order # 11-6512

**BLUE**

OD	Grade	12+	6+	1+
9/16"	Coarse	\$0.87	\$0.95	\$1.05
1 1/16"	Coarse	\$0.95	\$1.04	\$1.15
1"	Coarse	\$1.04	\$1.13	\$1.25



Order # 11-6516

**LIGHT GRAY**

OD	Grade	12+	6+	1+
9/16"	Extra Fine	\$0.87	\$0.95	\$1.05
1 1/16"	Extra Fine	\$0.95	\$1.04	\$1.15
1"	Extra Fine	\$1.04	\$1.13	\$1.25



**EVE FLEX TWIST**

Flexible lamellae enable polishing without altering the surface structure

**Order # 11-6411**

<b>OD</b>	9/16"	1 1/16"
<b>Thickness</b>	1/16"	1/16"
<b>Grade</b>	Extra Coarse	Extra Coarse
<b>12+</b>	\$2.58	\$2.58
<b>6+</b>	\$2.69	\$2.69
<b>1+</b>	\$2.80	\$2.80



**EVE FLEX TWIST**

Flexible lamellae enable polishing without altering the surface structure

**Order # 11-6412**

<b>OD</b>	9/16"	1 1/16"
<b>Thickness</b>	1/16"	1/16"
<b>Grade</b>	Coarse	Coarse
<b>12+</b>	\$2.58	\$2.58
<b>6+</b>	\$2.69	\$2.69
<b>1+</b>	\$2.80	\$2.80



**EVE FLEX TWIST**

Flexible lamellae enable polishing without altering the surface structure

**Order # 11-6413**

<b>OD</b>	9/16"	1 1/16"
<b>Thickness</b>	1/16"	1/16"
<b>Grade</b>	Medium	Medium
<b>12+</b>	\$2.58	\$2.58
<b>6+</b>	\$2.69	\$2.69
<b>1+</b>	\$2.80	\$2.80



**EVE FLEX TWIST**

Flexible lamellae enable polishing without altering the surface structure

**Order # 11-6414**

<b>OD</b>	9/16"	1 1/16"
<b>Thickness</b>	1/16"	1/16"
<b>Grade</b>	Fine	Fine
<b>12+</b>	\$2.58	\$2.58
<b>6+</b>	\$2.69	\$2.69
<b>1+</b>	\$2.80	\$2.80



**EVE FLEX TWIST**

Flexible lamellae enable polishing without altering the surface structure

**Order # 11-6415**

<b>OD</b>	9/16"	1 1/16"
<b>Thickness</b>	1/16"	1/16"
<b>Grade</b>	Extra Fine	Extra Fine
<b>12+</b>	\$2.58	\$2.58
<b>6+</b>	\$2.69	\$2.69
<b>1+</b>	\$2.80	\$2.80

**RADIAL BRISTLE DISCS**

The 3M® small radial bristle discs have a flexible bristle design that can be used for cleaning, pre-polishing, semi-finishing, blending and texturing. Excellent for gold, silver, copper, pewter and brass applications. Especially good for removing the oxides from jewelry without messy compounds. Great for cleaning and maintaining tiny, hard-to-reach areas and fine detail. Recommended speed for most applications: 15,000 RPM's, Maximum (MOS) 20,000

- 36 Grit
- Dark Brown
- 1" Recommended for the following uses:
- Heavy Scale Removal- 15,000 to 20,000 RPM's
- Heavy Cleaning - 15,000 to 20,000 RPM's

**Kit Order # 10-9104**

<b>Description</b>	<b>12+</b>	<b>6+</b>	<b>1+</b>
42-Piece Kit, 3/4"	\$36.43	\$38.02	\$39.60

**Order # 10-11023**

Material	Grit	Color	Micron	OD	12+	6+	1+
Pumice	80	Yellow	—	3/4"	\$1.24	\$1.30	\$1.35
Plastic	220	Red	—	3/4"	\$1.24	\$1.30	\$1.35
Pumice	400	Blue	—	3/4"	\$0.60	\$0.60	\$0.60
Pumice	—	Light Green	1 μ	3/4"	\$1.24	\$1.30	\$1.35
Plastic	—	Peach	6 μ	3/4"	\$1.24	\$1.30	\$1.35
Pumice	120	White	—	9/16"	\$1.36	\$1.44	\$1.60
Pumice	220	Red	—	9/16"	\$1.36	\$1.44	\$1.60
Pumice	400	Blue	—	9/16"	\$1.36	\$1.44	\$1.60
Pumice	—	Pink	—	9/16"	\$1.32	\$1.40	\$1.55
Plastic	—	Light Green	1 μ	9/16"	\$1.36	\$1.44	\$1.60
Pumice	—	Peach	6 μ	9/16"	\$1.32	\$1.40	\$1.55
Plastic	36	Brown	—	1"	\$1.32	\$1.40	\$1.55
Plastic	50	Light Green	—	1"	\$1.36	\$1.44	\$1.60
Plastic	80	Yellow	—	1"	\$1.36	\$1.44	\$1.60
Plastic	120	White	—	1"	\$1.36	\$1.44	\$1.60
Plastic	80	Yellow	—	2"	\$2.25	\$2.35	\$2.45
Plastic	120	White	—	2"	\$1.42	\$1.42	\$1.42
Pumice	220	Red	—	2"	\$2.25	\$2.35	\$2.45
Plastic	400	Blue	—	2"	\$2.25	\$2.35	\$2.45
Plastic	—	Light Green	1 μ	2"	\$2.12	\$2.21	\$2.30
Pumice	—	Peach	6 μ	2"	\$2.25	\$2.35	\$2.45
Pumice	—	Pink	—	2"	\$2.25	\$2.35	\$2.45
Pumice	80	Yellow	—	3"	\$3.13	\$3.26	\$3.40
Plastic	120	White	—	3"	\$2.99	\$3.12	\$3.25
Plastic	220	Red	—	3"	\$3.13	\$3.26	\$3.40
Plastic	400	Blue	—	3"	\$3.27	\$3.41	\$3.55
Pumice	—	Pink	—	3"	\$3.13	\$3.26	\$3.40
Pumice	—	Light Green	1 μ	3"	\$3.13	\$3.26	\$3.40
Pumice	—	Peach	6 μ	3"	\$3.13	\$3.26	\$3.40



**MICRO FIBER DISC**

These new micro-fiber, reinforced separating discs are superior in their cutting ability and are more economical due to their durability. Unlike most ultra-thin separating discs, these do not break easily even when bent. The quality and performance are unmatched by most cutting products.

Order #	Material	OD	Thickness	Per Pack	12+	6+	1+
<b>11-8206</b>	Silicon-Carbide	22"	0.3mm	Pack of 10	\$12.24	\$13.28	\$14.75
<b>11-8206</b>	Silicon-Carbide	22"	0.3mm	Pack of 100	\$95.63	\$101.25	\$112.50
<b>11-8207</b>	Aluminum-Oxide	22"	0.3mm	Pack of 10	\$12.24	\$13.28	\$14.75
<b>11-8207</b>	Aluminum-Oxide	22"	0.3mm	Pack of 100	\$95.63	\$101.25	\$112.50





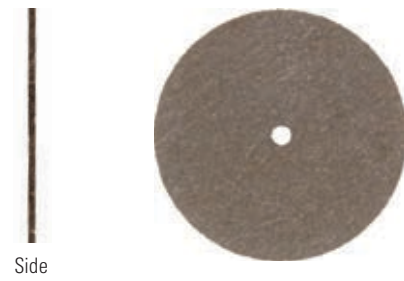

Side

### HIGH-QUALITY CUTOFF DISCS

Made of silicon carbide, these non-contaminating, extra durable discs feature extra thin cutting for gold. Use reinforced mandrel 43-1282.

Order #	OD	Thickness	Per Pack	12+	6+	1+
11-8190	7/8"	0.3mm	Box of 25	\$9.02	\$9.41	\$9.80
11-8192	7/8"	0.3mm	Box of 100	\$31.92	\$33.31	\$34.70
11-8194	7/8"	0.2mm	Box of 25	\$9.02	\$9.41	\$9.80
11-8196	7/8"	0.2mm	Box of 100	\$31.92	\$33.31	\$34.70

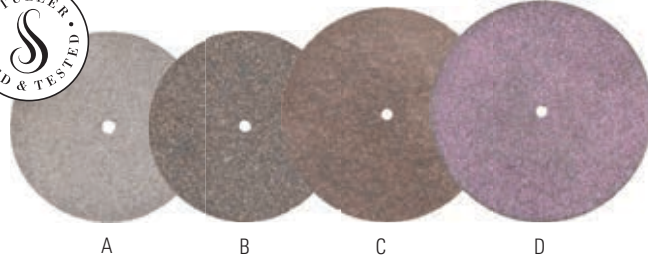

### ALUMINUM OXIDE CUTOFF WHEELS

Fast, cool, and odor-free wheels for cutting and finishing cobalt and hard metals.

Item	Order #	Color	OD	Thickness	12+	6+	1+
A	11-8240	Light Brown	1 1/4"	0.64mm	\$28.01	\$29.66	\$32.95
B	11-8242	Brown	1 1/4"	0.81mm	\$28.01	\$29.66	\$32.95
C	11-8244	Red	1 1/2"	0.64mm	\$28.01	\$29.66	\$32.95
D	11-8246	Ruby	1 1/2"	0.81mm	\$31.37	\$32.74	\$34.10



Side

### SEPARATING DISCS

High-speed, resin-bonded, aluminum oxide and silicon carbide separating discs. These are fast cutting, precise, and long lasting.

Order #	Material	OD	Thickness	12+	6+	1+
11-8197	Aluminum-Oxide	7/8"	0.23mm	\$40.76	\$42.53	\$44.30
11-8198	Aluminum-Oxide	7/8"	0.64mm	\$10.49	\$10.94	\$11.40
11-8204	Silicon-Carbide	7/8"	0.23mm	\$40.76	\$42.53	\$44.30
11-8205	Silicon-Carbide	7/8"	0.64mm	\$11.50	\$12.00	\$12.50

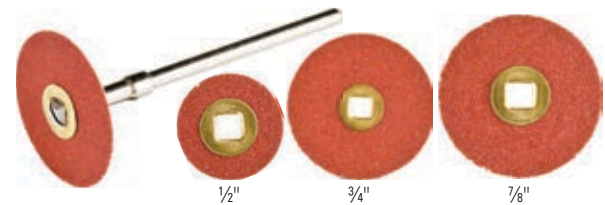

### ADALOX® ALUMINUM OXIDE SNAP-ON DISCS

These reddish-brown aluminum oxide discs are less aggressive than emery and feature thin, resin-bonded, flexible paper. Use with snap-on mandrel 10-7050.

Order # 10-11024

Grade	OD	12+	6+	1+
Coarse	1/2"	\$4.19	\$4.37	\$4.55
Medium	1/2"	\$4.19	\$4.37	\$4.55
Fine	1/2"	\$4.19	\$4.37	\$4.55
Coarse	3/4"	\$4.23	\$4.42	\$4.60
Medium	3/4"	\$4.23	\$4.42	\$4.60
Fine	3/4"	\$4.23	\$4.42	\$4.60
Coarse	7/8"	\$4.23	\$4.42	\$4.60
Medium	7/8"	\$4.23	\$4.42	\$4.60
Fine	7/8"	\$4.23	\$4.42	\$4.60

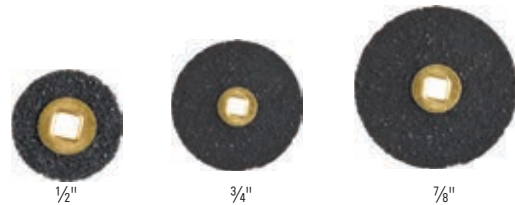

### SILICON CARBIDE DISCS

These black, silicon carbide discs are less aggressive than emery and feature thin, resin-bonded, flexible paper. Use with snap-on mandrel 10-7050.

Order # 10-11025

Grade	OD	12+	6+	1+
Coarse	1/2"	\$4.19	\$4.37	\$4.55
Medium	1/2"	\$4.19	\$4.37	\$4.55
Fine	1/2"	\$4.19	\$4.37	\$4.55
Coarse	3/4"	\$4.19	\$4.37	\$4.55
Medium	3/4"	\$4.19	\$4.37	\$4.55
Fine	3/4"	\$4.19	\$4.37	\$4.55
Coarse	7/8"	\$4.19	\$4.37	\$4.55
Medium	7/8"	\$4.23	\$4.42	\$4.60
Fine	7/8"	\$4.19	\$4.37	\$4.55

### ZIRCONIA PINHOLE SANDING DISCS

Zirconia sanding discs are superior to other conventional abrasives. They aggressively cut and grind metals with uniform, file-like finish, making them ideal for platinum use. Prolong life by using water as a lubricant. Mandrels sold separately.



Order # 10-11030

Grade	OD	12+	6+	1+
Coarse	3/4"	\$8.26	\$8.96	\$9.95
Medium	3/4"	\$8.26	\$8.96	\$9.95
Fine	3/4"	\$8.26	\$8.96	\$9.95
Coarse	7/8"	\$8.26	\$8.96	\$9.95
Medium	7/8"	\$8.26	\$8.96	\$9.95
Fine	7/8"	\$8.26	\$8.96	\$9.95

Mandrel 43-1280	12+	6+	1+
Reinforced Screw Mandrel	\$0.94	\$0.99	\$1.10



### SNAP-ON SANDING DISCS

Mandrels sold separately.

Order # 10-11031

Grade	OD	12+	6+	1+
Coarse	7/8"	\$8.34	\$9.05	\$10.05
Medium	7/8"	\$8.34	\$9.05	\$10.05
Fine	7/8"	\$8.34	\$9.05	\$10.05

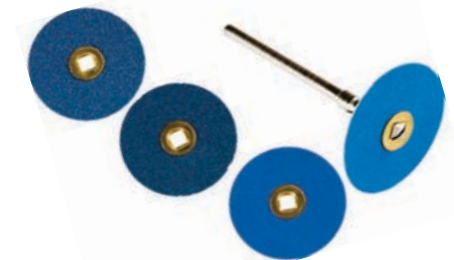

### MOORE'S MAGNUM POLISHERS

Moore's Magnum Polishers feature unique felt-like surfaces specially designed for working with all polishing parts.

Order #	Grade	OD	12+	6+	1+
10-7108	Fine	3/4"	\$24.98	\$26.06	\$27.15
10-7140	Fine	7/8"	\$24.98	\$26.06	\$27.15



### PINK ALUMINUM OXIDE POINTS

Long-lasting pink aluminum oxide points are ideal for fine finishing of non-precious and semi-precious metals. Non-contaminating.

Order # 11-10000

Item	Shape	12+	6+	1+
A	Point	\$21.38	\$22.64	\$25.15
B	Cylinder	\$21.38	\$22.64	\$25.15
C	Cone	\$21.38	\$22.64	\$25.15
D	Inverted Cone	\$21.38	\$22.64	\$25.15
E	Round	\$21.38	\$22.64	\$25.15



### KONTOUR DIAMOND-IMPREGNATED STONES

Diamond-impregnated stones give off very little heat and will cut time when working with harder metals. Medium grit stones used for shaping and contouring. Mounted on 3/32" shanks.

Item	Order #	Shape	OD	Thickness	12+	6+	1+
F	28-6001	Square-Edge	5/8"	1/8"	\$40.25	\$42.00	\$43.75
G	28-6006	Square-Edge	7/8"	1/8"	\$40.25	\$42.00	\$43.75
H	28-6005	Knife-Edge	7/8"	1/8"	\$40.25	\$42.00	\$43.75

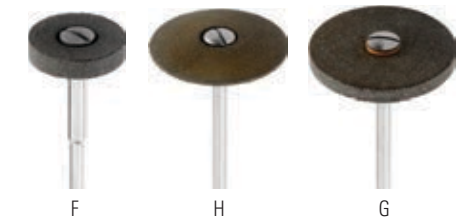

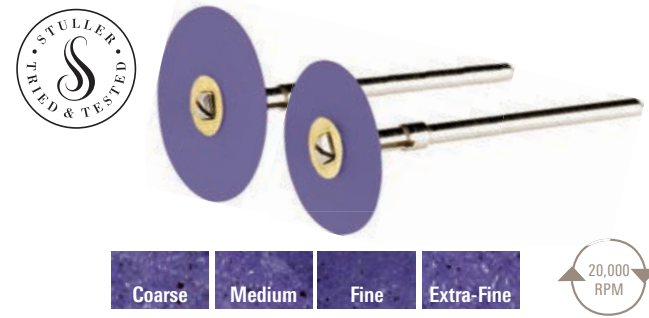

**MOORE PLASTIC SNAP-ON DISCS**  
Sand/plastic snap-on discs are made of white, aluminum-oxide that is bonded to a plastic back. Works well on contoured surfaces. Use with snap-on mandrel 10-7050.

Order # 10-11028 50

Grade	OD	12+	6+	1+
Medium	7/8"	\$5.95	\$6.30	\$7.00
Fine	7/8"	\$5.95	\$6.30	\$7.00
Extra Fine	7/8"	\$5.95	\$6.30	\$7.00
Coarse	3/4"	\$5.95	\$6.30	\$7.00
Medium	3/4"	\$5.95	\$6.30	\$7.00
Fine	3/4"	\$5.95	\$6.30	\$7.00
Extra Fine	3/4"	\$5.95	\$6.30	\$7.00

Mandrel Order # 10-7050	12+	6+	1+
Snap-On Mandrel (3/2" shank)	\$1.74	\$1.89	\$2.10

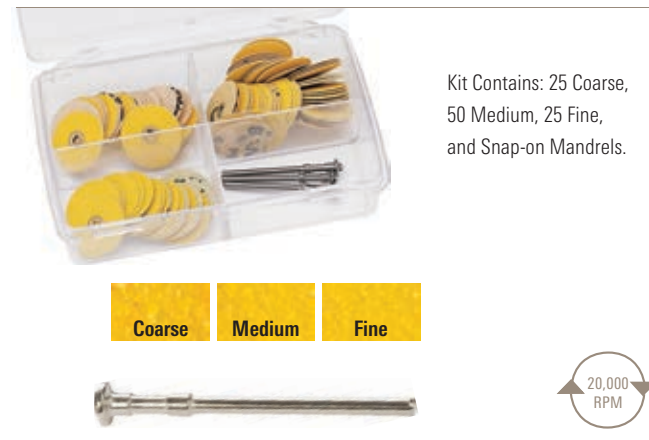

**YELLOW SANDING DISCS**  
This yellow abrasive disc with snap-on feature is used in the pre-finishing process. Exclusive aluminum oxide grit provides excellent results in sanding and smoothing operations. Hard-to-reach places are accessible with the flexible backing.

Order # 10-11029 100

Grade	OD	12+	6+	1+
Coarse	3/4"	\$8.51	\$8.88	\$9.25
Medium	3/4"	\$8.51	\$8.88	\$9.25
Fine	3/4"	\$8.42	\$8.78	\$9.15
Coarse	7/8"	\$8.42	\$8.78	\$9.15
Medium	7/8"	\$8.42	\$8.78	\$9.15
Fine	7/8"	\$8.42	\$8.78	\$9.15

Mandrel Order # 10-7050	12+	6+	1+
Snap-On Mandrel (3/2" shank)	\$1.74	\$1.89	\$2.10

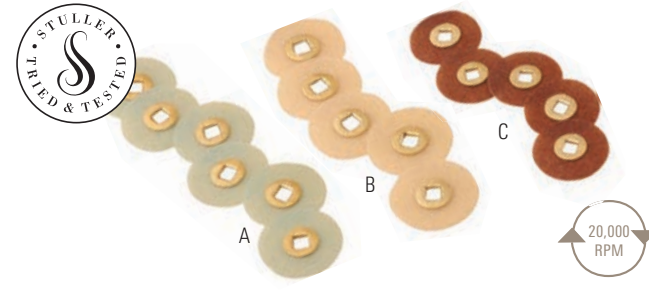

**MAGNUM SNAP-ON SANDING DISCS**  
The aluminum oxide discs work similarly to the Moor plastic and Adalox® discs. They are designed with a special reinforced, waterproof backing. This disc is recommended for fast cutting of acrylics and is excellent for polishing non-precious alloys. Use with snap-on mandrel 10-7050.

Order # 10-11026 100

Item	Grade	Color	OD	12+	6+	1+
A	Fine	Green	7/8"	\$11.64	\$12.14	\$12.65
B	Medium	White	7/8"	\$11.64	\$12.14	\$12.65
C	Coarse	Reddish Brown	7/8"	\$11.64	\$12.14	\$12.65

Mandrel Order # 10-7050	12+	6+	1+
Snap-On Mandrel (3/2" shank)	\$1.74	\$1.89	\$2.10

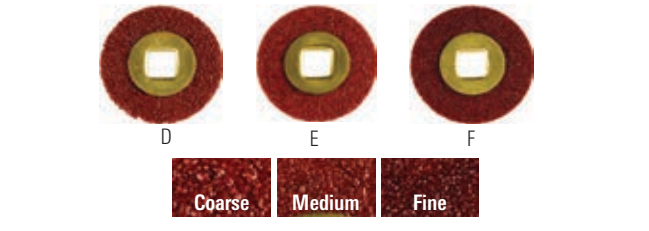

**ALUMINUM OXIDE SANDING DISCS**  
Aluminum oxide grit provides excellent results in sanding and smoothing operations. The flexible backing allows access to hard-to-reach areas. Use with snap-on mandrel 10-7050.

Order # 10-11027 100

Item	Grade	Color	OD	12+	6+	1+
D	Coarse	Brown	1/2"	\$13.05	\$13.82	\$15.35
E	Medium	Brown	1/2"	\$13.05	\$13.82	\$15.35
F	Fine	Brown	1/2"	\$13.05	\$13.82	\$15.35

Mandrel Order # 10-7050	12+	6+	1+
Snap-On Mandrel (3/2" shank)	\$1.74	\$1.89	\$2.10

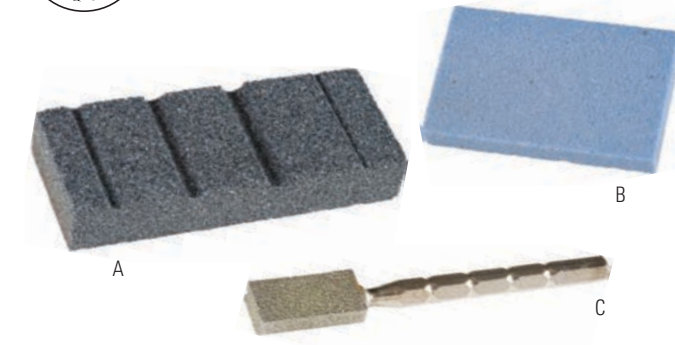

**DIAMOND-COATED DRESSING STONE**  
This diamond-coated block allows fast dressing and shaping of silicone and rubber polishers.

**BLUE DRESSING STONE**  
Light blue abrasive stone used to shape and contour polishers.

**DRESSING STONE**  
Hard, coarse, silicon carbide block with various sized, half-round grooves for cleaning and reshaping abrasive points and wheels.

Item	Order #	Description	WxL	Thickness	12+	6+	1+
A	10-4080	Dressing Stone	1 3/8" x 3 1/2"	3/16"	\$6.35	\$6.62	\$6.90
B	11-6260	Blue Stone	20" x 33"	4"	\$3.17	\$3.31	\$3.45
C	11-6261	Diamond Coated	12" x 25"	6"	\$45.73	\$49.59	\$55.10
	34-2302	Dressing Stone	12" x 25"	6"	\$7.68	\$8.02	\$8.35

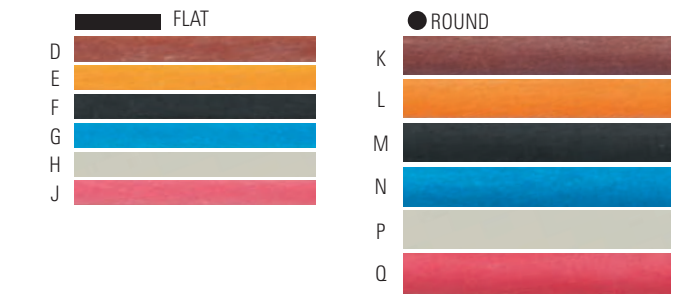

**CERAMIC STONES**  
Ceramic stones are designed for stoning tight corners, pockets, ribs, and slots. One of our most popular series of finishing stones, these are ideal for finishing EDM surfaces. Ceramic super stones will withstand considerable pressure for their relative thinness. The grit of the ceramic fiber is exposed in the cross section of the stones.

Item	Order #	Grit	Color	WxL	Thickness	12+	6+	1+
FLAT								
D	21-1200	300	Light Brown	2 1/2" x 100mm	1mm	\$10.76	\$11.23	\$11.70
E	21-1201	400	Orange	2 1/2" x 100mm	1mm	\$10.76	\$11.23	\$11.70
F	21-1202	600	Brown	2 1/2" x 100mm	1mm	\$10.76	\$11.23	\$11.70
G	21-1203	800	Blue	2 1/2" x 100mm	1mm	\$10.76	\$11.23	\$11.70
H	21-1204	1000	White	2 1/2" x 100mm	1mm	\$10.76	\$11.23	\$11.70
J	21-1205	1200	Red	2 1/2" x 100mm	1mm	\$10.76	\$11.23	\$11.70
ROUND								
K	21-1206	300	Light Brown	3 1/8" x 50mm	3/8mm	\$24.15	\$25.20	\$26.25
L	21-1207	400	Orange	3 1/8" x 50mm	3/8mm	\$24.66	\$25.73	\$26.80
M	21-1208	600	Brown	3 1/8" x 50mm	3/8mm	\$24.66	\$25.73	\$26.80
N	21-1209	800	Blue	3 1/8" x 50mm	3/8mm	\$24.66	\$25.73	\$26.80
P	21-1210	1000	White	3 1/8" x 50mm	3/8mm	\$24.66	\$25.73	\$26.80
Q	21-1211	1200	Red	3 1/8" x 50mm	3/8mm	\$24.66	\$25.73	\$26.80

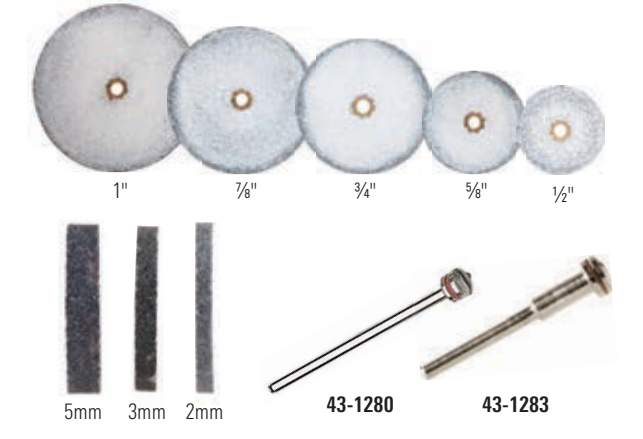

**GENUINE HEATLESS MIZZY WHEELS**  
These unique square-edge wheels are made from silicon carbide and a non-loading binder. Heatless Mizzy Wheels can be used for fast grinding or preparing contact finishes and texturing. Mandrels sold separately.

Order # 11-40000

Width	OD	Thickness	Per Pack	12+	6+	1+
2mm	1/2"	2"	Pack of 10	\$5.06	\$5.28	\$5.50
3mm	1/2"	3"	Pack of 10	\$5.06	\$5.28	\$5.50
3mm	1/2"	3"	Pack of 10	\$5.06	\$5.28	\$5.50
5mm	1/2"	5"	Pack of 10	\$5.06	\$5.28	\$5.50
5mm	1/2"	5"	Pack of 10	\$5.06	\$5.28	\$5.50
2mm	5/8"	2"	Pack of 10	\$5.06	\$5.28	\$5.50
2mm	5/8"	2"	Pack of 10	\$5.06	\$5.28	\$5.50
3mm	5/8"	3"	Pack of 10	\$5.06	\$5.28	\$5.50
5mm	5/8"	5"	Pack of 10	\$5.06	\$5.28	\$5.50
5mm	5/8"	5"	Pack of 10	\$5.06	\$5.28	\$5.50
2mm	3/4"	2"	Pack of 10	\$5.06	\$5.28	\$5.50
2mm	3/4"	2"	Pack of 10	\$5.06	\$5.28	\$5.50
3mm	3/4"	3"	Pack of 50	\$5.06	\$5.28	\$5.50
3mm	3/4"	3"	Pack of 50	\$22.49	\$23.47	\$24.45
5mm	3/4"	5"	Pack of 50	\$22.49	\$23.47	\$24.45
5mm	3/4"	5"	Pack of 50	\$22.49	\$23.47	\$24.45
2mm	7/8"	2"	Pack of 50	\$22.49	\$23.47	\$24.45
2mm	7/8"	2"	Pack of 50	\$22.49	\$23.47	\$24.45
3mm	7/8"	3"	Pack of 50	\$22.49	\$23.47	\$24.45
3mm	7/8"	3"	Pack of 50	\$22.49	\$23.47	\$24.45
5mm	7/8"	5"	Pack of 50	\$22.49	\$23.47	\$24.45
5mm	7/8"	5"	Pack of 50	\$22.49	\$23.47	\$24.45
2mm	1"	2"	Pack of 50	\$22.49	\$23.47	\$24.45
2mm	1"	2"	Pack of 50	\$22.49	\$23.47	\$24.45
3mm	1"	3"	Pack of 50	\$22.49	\$23.47	\$24.45
3mm	1"	3"	Pack of 50	\$22.49	\$23.47	\$24.45
5mm	1"	5"	Pack of 50	\$22.49	\$23.47	\$24.45
5mm	1"	5"	Pack of 50	\$22.49	\$23.47	\$24.45
2mm	1/2"	2"	Pack of 50	\$22.49	\$23.47	\$24.45

Mandrels	12+	6+	1+
43-1280 Reinforced Screw Mandrel	\$0.94	\$0.99	\$1.10
43-1283 1/8" Mandrel (1/8" shank with one silver cap for 1/8" and 1/4" thick wheels)	\$1.48	\$1.67	\$1.85





Contains four square-edge, four knife-edge, one cylinder of each grit and size with mandrels.

Order # 11-60000



### UNMOUNTED SILICONE POLISHING WHEELS

Premium unmounted silicone polishing wheels. Silicone rubber for flexibility and smooth finishing. Each wheel is impregnated with carefully graded silicon-carbide abrasive. These wheels provide a superior finish without messy compounds at a great price. Unmounted wheels have a 1/16" arbor hole. Imported from Germany. Mandrels available on page 32.

<b>Kit Order #11-6052</b>	<b>12+</b>	<b>6+</b>	<b>1+</b>
117-Piece Kit Assortment	\$45.52	\$48.20	\$53.55



#### STEP 1

White  
100 Grit  
Coarse



OD	7/8"	7/8"	5/8"	7/8"	7/8"	5/8"	5/16"	3/8"	1/2"	9/16"
Thickness	1/8"	1/4"	1/8"	1/16"	1/8"	1/8"	13/16"	7/8"	7/8"	1"
Shape	Square-Edge	Square-Edge	Square-Edge	Square-Edge	Knife-Edge	Knife-Edge	Cylinder	Cylinder	Cylinder	Cylinder
12+	\$0.62	\$0.91	\$0.62	\$0.62	\$0.62	\$0.62	\$0.62	\$0.75	\$0.91	\$1.41
6+	\$0.68	\$0.99	\$0.68	\$0.68	\$0.68	\$0.68	\$0.68	\$0.81	\$0.99	\$1.53
1+	\$0.75	\$1.10	\$0.75	\$0.75	\$0.75	\$0.75	\$0.75	\$0.90	\$1.10	\$1.70

#### STEP 2

Black  
220 Grit  
Medium



OD	7/8"	7/8"	5/8"	7/8"	7/8"	5/8"	5/16"	3/8"	1/2"	9/16"
Thickness	1/8"	1/4"	1/8"	1/16"	1/8"	1/8"	13/16"	7/8"	7/8"	1"
Shape	Square-Edge	Square-Edge	Square-Edge	Square-Edge	Knife-Edge	Knife-Edge	Cylinder	Cylinder	Cylinder	Cylinder
12+	\$0.62	\$0.91	\$0.62	\$0.62	\$0.62	\$0.62	\$0.62	\$0.75	\$0.91	\$1.41
6+	\$0.68	\$0.99	\$0.68	\$0.68	\$0.68	\$0.68	\$0.68	\$0.81	\$0.99	\$1.53
1+	\$0.75	\$1.10	\$0.75	\$0.75	\$0.75	\$0.75	\$0.75	\$0.90	\$1.10	\$1.70

#### STEP 3

Blue  
800 Grit  
Fine



OD	7/8"	7/8"	5/8"	7/8"	7/8"	5/8"	5/16"	3/8"	1/2"	9/16"
Thickness	1/8"	1/4"	1/8"	1/16"	1/8"	1/8"	13/16"	7/8"	7/8"	1"
Shape	Square-Edge	Square-Edge	Square-Edge	Square-Edge	Knife-Edge	Knife-Edge	Cylinder	Cylinder	Cylinder	Cylinder
12+	\$0.69	\$1.01	\$0.69	\$0.69	\$0.69	\$0.69	\$0.69	\$0.83	\$1.01	\$1.56
6+	\$0.72	\$1.06	\$0.72	\$0.72	\$0.72	\$0.72	\$0.72	\$0.86	\$1.06	\$1.63
1+	\$0.75	\$1.10	\$0.75	\$0.75	\$0.75	\$0.75	\$0.75	\$0.90	\$1.10	\$1.70

#### STEP 4

Pink  
1200 Grit  
Extra Fine



OD	7/8"	7/8"	5/8"	7/8"	7/8"	5/8"	5/16"	3/8"	1/2"	9/16"
Thickness	1/8"	1/4"	1/8"	1/16"	1/8"	1/8"	13/16"	7/8"	7/8"	1"
Shape	Square-Edge	Square-Edge	Square-Edge	Square-Edge	Knife-Edge	Knife-Edge	Cylinder	Cylinder	Cylinder	Cylinder
12+	\$0.62	\$0.91	\$0.62	\$0.62	\$0.62	\$0.62	\$0.62	\$0.75	\$0.91	\$1.41
6+	\$0.68	\$0.99	\$0.68	\$0.68	\$0.68	\$0.68	\$0.68	\$0.81	\$0.99	\$1.53
1+	\$0.75	\$1.10	\$0.75	\$0.75	\$0.75	\$0.75	\$0.75	\$0.90	\$1.10	\$1.70



### MOUNTED SILICONE POLISHING WHEELS

Premium, ready-to-use, mounted silicone polishers. Get a superior finish without the messy compounds. Excellent for karat golds, platinum, and palladium. 3/32" shanks.

<b>Kit Order # 11-6120</b>	<b>12+</b>	<b>6+</b>	<b>1+</b>
32-Piece Kit: Two of each	\$28.65	\$30.33	\$33.70

Order #11-62000

STEP 1  
Aggressive  
Pre-Finish  
White/100 Grit  
Coarse



OD	1/4"	1/4"	7/16"	7/16"
Thickness	3/8"	1 1/16"	1/8"	1/8"
Shape	Point	Bullet	Square-Edge	Knife-Edge
12+	\$0.96	\$0.96	\$0.96	\$0.96
6+	\$1.08	\$1.08	\$1.08	\$1.08
1+	\$1.20	\$1.20	\$1.20	\$1.20

STEP 2  
Pre-Finish  
Black/220 Grit  
Medium



OD	1/4"	1/4"	7/16"	7/16"
Thickness	3/8"	1 1/16"	1/8"	1/8"
Shape	Point	Bullet	Square-Edge	Knife-Edge
12+	\$0.96	\$0.96	\$0.96	\$0.96
6+	\$1.08	\$1.08	\$1.08	\$1.08
1+	\$1.20	\$1.20	\$1.20	\$1.20

STEP 3  
Finish  
Blue/800 Grit  
Fine



OD	1/4"	1/4"	7/16"	7/16"
Thickness	3/8"	1 1/16"	1/8"	1/8"
Shape	Point	Bullet	Square-Edge	Knife-Edge
12+	\$0.96	\$0.96	\$0.96	\$0.96
6+	\$1.08	\$1.08	\$1.08	\$1.08
1+	\$1.20	\$1.20	\$1.20	\$1.20

STEP 4  
High Polish  
Pink/1200 Grit  
Extra Fine



OD	1/4"	1/4"	7/16"	7/16"
Thickness	3/8"	1 1/16"	1/8"	1/8"
Shape	Point	Bullet	Square-Edge	Knife-Edge
12+	\$0.96	\$0.96	\$0.96	\$0.96
6+	\$1.08	\$1.08	\$1.08	\$1.08
1+	\$1.20	\$1.20	\$1.20	\$1.20



#### GOLD POLISHING KIT

An introductory kit with a generous amount of our standard sized silicone pre-polished, high shine, and long life wheels along with mini-point cylinders and mandrels.



<b>Order #</b>	<b>Description</b>	<b>12+</b>	<b>6+</b>	<b>1+</b>
<b>11-8100</b>	44-Piece Gold Kit	\$41.22	\$43.01	\$44.80



#### PLATINUM/GOLD POLISHING KIT

The most complete kit available features a wide range of silicone pre-polish and high shine wheels: Cutting discs for gold in two sizes; mini-points, mandrels, and cylinders for inside rings; and silipum wheels that won't scratch the stones. Wheels come in square-edge, knife-edge, 7/8", and 5/8". This kit will handle all your polishing needs.



<b>Order #</b>	<b>Description</b>	<b>12+</b>	<b>6+</b>	<b>1+</b>
<b>11-8110</b>	70-Piece Platinum/Gold Polishing Kit	\$48.02	\$50.11	\$52.20

**STULLER PREMIUM SILICONE POLISHERS**

The ultimate polishers for gold and all precious metal alloys in an easy three-step process. Made in Switzerland.

Order #11-61000



**GREEN**  
Finish

20,000 RPM

OD	1/8"	7/32"	7/8"	7/8"
Thickness	7/8"	5/8"	1/8"	1/8"
Shape	Cylinder	Point	Knife-Edge	Square-Edge
12+	\$0.74	\$1.10	\$0.74	\$0.74
6+	\$0.77	\$1.15	\$0.77	\$0.77
1+	\$0.80	\$1.20	\$0.80	\$0.80

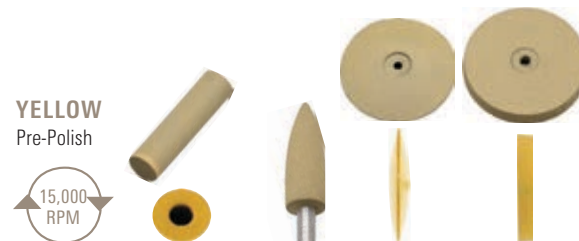

**YELLOW**  
Pre-Polish

15,000 RPM

OD	1/8"	7/32"	7/8"	7/8"
Thickness	7/8"	5/8"	1/8"	1/8"
Shape	Cylinder	Point	Knife-Edge	Square-Edge
12+	\$0.74	\$1.10	\$0.74	\$0.74
6+	\$0.77	\$1.15	\$0.77	\$0.77
1+	\$0.80	\$1.20	\$0.80	\$0.80

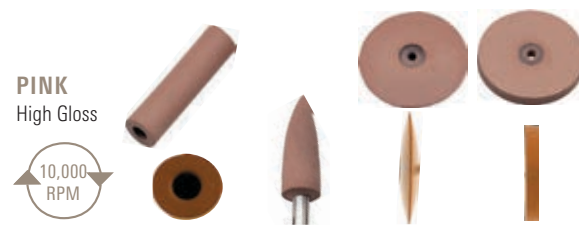

**PINK**  
High Gloss

10,000 RPM

OD	1/8"	7/32"	7/8"	7/8"
Thickness	7/8"	5/8"	1/8"	1/8"
Shape	Cylinder	Point	Knife-Edge	Square-Edge
12+	\$0.74	\$1.10	\$0.74	\$0.74
6+	\$0.77	\$1.15	\$0.77	\$0.77
1+	\$0.80	\$1.20	\$0.80	\$0.80

**SILICONE PRE-POLISH WHEELS**

A coarse wheel for fast cutting and leaving a very smooth surface. Slightly harder and longer lasting than the flexible gray.

Order # 11-81000



**BLUE**  
120 Grit Firm

OD	7/8"	7/8"	1/4"
Thickness	1/8"	1/8"	7/8"
Shape	Square-Edge	Knife-Edge	Cylinder
12+	\$5.57	\$5.57	\$5.57
6+	\$5.81	\$5.81	\$5.81
1+	\$6.05	\$6.05	\$6.05

A dark gray coarse polisher for precious and semi-precious. Leaves a brilliant satin finish that removes scratches and prepares the material for a high-shine gloss.



**GRAY**  
180 Grit Flexible

OD	7/8"	5/8"	7/8"	5/8"	1/4"
Thickness	1/8"	1/8"	1/8"	1/8"	7/8"
Shape	Square-Edge	Square-Edge	Knife-Edge	Knife-Edge	Cylinder
12+	\$5.57	\$5.57	\$5.57	\$5.57	\$5.57
6+	\$5.81	\$5.81	\$5.81	\$5.81	\$5.81
1+	\$6.05	\$6.05	\$6.05	\$6.05	\$6.05

One step harder than the dark gray, this wheel is more coarse and aggressive. Used for precious and non-precious. Excellent for deep scratches.



**WHITE**  
180 Grit Hard

OD	7/8"	5/8"	7/8"	5/8"
Thickness	1/8"	1/8"	1/8"	1/8"
Shape	Square-Edge	Square-Edge	Knife-Edge	Knife-Edge
12+	\$5.57	\$5.57	\$5.57	\$5.57
6+	\$5.81	\$5.81	\$5.81	\$5.81
1+	\$6.05	\$6.05	\$6.05	\$6.05

A wheel made specifically for platinum and softer materials. Pre-polisher that leaves an extremely smooth finish and prepares for the final high-shine.



**LIGHT GREEN**  
200 Grit

OD	7/8"	5/8"	7/8"	5/8"
Thickness	1/8"	1/8"	1/8"	1/8"
Shape	Square-Edge	Square-Edge	Knife-Edge	Knife-Edge
12+	\$5.57	\$5.57	\$5.57	\$5.57
6+	\$5.81	\$5.81	\$5.81	\$5.81
1+	\$6.05	\$6.05	\$6.05	\$6.05



**UNMOUNTED SILICONE PRE-POLISH WHEELS**

A soft silicone wheel for high gloss. Very smooth, leaving a brilliant glossy coat.



**LIGHT BLUE**  
800 Grit

Order #	11-8172	11-8174
OD	7/8"	7/8"
Thickness	1/8"	1/8"
Shape	Square-Edge	Knife-Edge
12+	\$6.30	\$6.30
6+	\$6.58	\$6.58
1+	\$6.85	\$6.85

**PINK**  
1200 Grit

Order #	11-8152	11-8154	11-8156	11-8158	11-8162
OD	7/8"	5/8"	7/8"	5/8"	1/8"
Thickness	1/8"	1/8"	1/8"	1/8"	7/8"
Shape	Square-Edge	Square-Edge	Knife-Edge	Knife-Edge	Cylinder
12+	\$6.30	\$6.30	\$6.30	\$6.30	\$6.30
6+	\$6.58	\$6.58	\$6.58	\$6.58	\$6.58
1+	\$6.85	\$6.85	\$6.85	\$6.85	\$6.85

Used to remove light scratches quickly, leaving a smooth, even finish. Silicon carbide abrasive allows medium fast cutting while the silicone rubber bond produces a smooth finish. Soft, flexible polishers for satin finishes. Made in Germany.



**BLUE**  
Medium Flexible

Order #	11-6060	11-6061	11-6062	11-6063	11-6064
OD	5/8"	7/8"	5/8"	7/8"	5/16"
Thickness	1/8"	1/8"	1/8"	1/8"	13/16"
Shape	Square-Edge	Square-Edge	Knife-Edge	Knife-Edge	Cylinder
12+	\$0.64	\$0.64	\$0.64	\$0.64	\$0.64
6+	\$0.67	\$0.67	\$0.67	\$0.67	\$0.67
1+	\$0.70	\$0.70	\$0.70	\$0.70	\$0.70

Revolutionary green wheel for long-lasting and highly flexible polishers for precious metals. Made from the highest quality raw materials available. Soft, extremely flexible for a matte finish. Made in Germany.



**GREEN**  
Medium

Order #	11-6080	11-6081	11-6082	11-6083	11-6084	11-6085	11-6086	11-6087	11-6088
OD	7/8"	5/8"	1/2"	5/16"	1/4"	7/8"	3/4"	5/8"	1/2"
Thickness	1/8"	1/8"	1/8"	13/16"	1"	3/16"	1/8"	1/8"	1/16"
Shape	Square-Edge	Square-Edge	Square-Edge	Cylinder	Bullet	Knife-Edge	Knife-Edge	Knife-Edge	Knife-Edge
12+	\$0.60	\$0.60	\$0.60	\$0.60	\$0.60	\$0.60	\$0.60	\$0.60	\$0.60
6+	\$0.63	\$0.63	\$0.63	\$0.63	\$0.63	\$0.63	\$0.63	\$0.63	\$0.63
1+	\$0.70	\$0.70	\$0.70	\$0.70	\$0.70	\$0.70	\$0.70	\$0.70	\$0.70







**MOUNTED SYNTHETIC RUBBER POLISHERS**

These flexible polishers are excellent for precious metals but also work well on brass, bronze, and other non-precious metals. Mounted acrylic, rubber polishers are slightly harder than silicone rubber and longer lasting. Safe for use with stones. These ready-to-use polishers are all mounted on 3/32" shank mandrels. Kit excludes smallest point.



<b>Kit Order #11-6124</b>	<b>12+</b>	<b>6+</b>	<b>1+</b>
24-Piece Kit: One of each	\$30.91	\$32.26	\$33.60

**Order # 11-61210**

**BLUE**  
Coarse



OD	1/8"	1/4"	1/4"	5/8"	3/4"	5/8"	5/8"
Thickness	3/8"	3/4"	1 1/16"	1/8"	1/16"	1/8"	1/2"
Shape	Point	Point	Bullet	Knife-Edge	Knife-Edge	Square-Edge	Cylinder
12+	\$1.24	\$1.24	\$1.24	\$1.49	\$1.49	\$2.44	\$2.20
6+	\$1.40	\$1.40	\$1.40	\$1.58	\$1.58	\$2.54	\$2.39
1+	\$1.55	\$1.55	\$1.55	\$1.75	\$1.75	\$2.65	\$2.65

**GRAY**  
Medium



OD	1/8"	1/4"	1/4"	5/8"	3/4"	5/8"	5/8"
Thickness	3/8"	3/4"	1 1/16"	1/8"	1/16"	1/8"	1/2"
Shape	Point	Point	Bullet	Knife-Edge	Knife-Edge	Square-Edge	Cylinder
12+	\$1.24	\$1.32	\$1.43	\$1.49	\$1.49	\$2.20	\$2.20
6+	\$1.40	\$1.40	\$1.49	\$1.58	\$1.58	\$2.39	\$2.39
1+	\$1.55	\$1.55	\$1.55	\$1.75	\$1.75	\$2.65	\$2.65

**RED**  
Fine



OD	1/8"	1/4"	1/4"	5/8"	3/4"	5/8"	5/8"
Thickness	3/8"	3/4"	1 1/16"	1/8"	1/16"	1/8"	1/2"
Shape	Point	Point	Bullet	Knife-Edge	Knife-Edge	Square-Edge	Cylinder
12+	\$1.24	\$1.24	\$1.24	\$1.40	\$1.40	\$2.20	\$2.20
6+	\$1.40	\$1.40	\$1.40	\$1.58	\$1.58	\$2.39	\$2.39
1+	\$1.55	\$1.55	\$1.55	\$1.75	\$1.75	\$2.65	\$2.65

**GREEN**  
Extra Fine



OD	1/8"	1/4"	1/4"	5/8"	3/4"	5/8"	5/8"
Thickness	3/8"	3/4"	1 1/16"	1/8"	1/16"	1/8"	1/2"
Shape	Point	Point	Bullet	Knife-Edge	Knife-Edge	Square-Edge	Cylinder
12+	\$1.24	\$1.24	\$1.24	\$1.23	\$1.40	\$2.20	\$2.20
6+	\$1.40	\$1.40	\$1.40	\$1.40	\$1.58	\$2.39	\$2.39
1+	\$1.55	\$1.55	\$1.55	\$1.75	\$1.75	\$2.65	\$2.65



**UNMOUNTED ACRYLIC POLISHERS.** Square wheels use mandrel 43-1280 or 43-1282. Cylinders use mandrel 43-1280 or 43-1286.



**Order #11-61850**

**SQUARE-EDGE**



**CYLINDER**



Grade	Coarse	Medium	Fine	Extra Fine
Color	Blue	Gray	Red	Green
OD	7/8"	7/8"	7/8"	7/8"
Thickness	1/8"	1/8"	1/8"	1/8"
12+	\$0.69	\$0.69	\$0.69	\$0.69
6+	\$0.72	\$0.72	\$0.72	\$0.72
1+	\$0.75	\$0.75	\$0.75	\$0.75

Grade	Coarse	Medium	Fine	Extra Fine
Color	Blue	Gray	Red	Green
OD	5/16"	5/16"	5/16"	5/16"
Thickness	13/16"	13/16"	13/16"	13/16"
12+	\$0.69	\$0.69	\$0.69	\$0.69
6+	\$0.72	\$0.72	\$0.72	\$0.72
1+	\$0.75	\$0.75	\$0.75	\$0.75

**EVEFLEX TECHNIK SERIES 400**

Hard and long-lasting polishers for non-precious alloys and model casting material. Use for grinding and pre-polishing, removing casting skin, non-precious metals and model casting. Very hard wear-resistant polishers offering a high level of material removal. Featuring a hard, flexible synthetic rubber binder.

**Order # 11-65200**



**BROWN**  
Medium



OD	7/8"	7/8"	9/16"	1 1/16"	1/4"	1/8"
Thickness	1/8"	3/16"	13/16"	1/16"	3/4"	3/8"
Shape	Square-Edge	Square-Edge	Cylinder	Square-Edge	Point	Point
12+	\$0.63	\$0.63	\$0.63	\$0.63	\$1.12	\$1.12
6+	\$0.72	\$0.72	\$0.72	\$0.72	\$1.26	\$1.26
1+	\$0.90	\$0.90	\$0.90	\$0.90	\$1.40	\$1.40

**POLISHING RODS**

Long-lasting, acrylic polishing rods give you a smooth finish in all of your hard-to-reach places. Excellent for use on non-precious and precious metals. Available in 2mm and 3mm diameters and five abrasive grades. Kits include 10 of each rod and a mandrel.



Order #	Grade	Color	OD	Length	12+	6+	1+
11-6165	Extra Coarse	Brown	2mm	20mm	\$0.87	\$0.91	\$0.95
11-6166	Hard	Blue	2mm	20mm	\$0.87	\$0.91	\$0.95
11-6167	Medium	Gray	2mm	20mm	\$0.87	\$0.91	\$0.95
11-6168	Fine	Reddish Brown	2mm	20mm	\$0.87	\$0.91	\$0.95
11-6169	Extra Fine	Green	2mm	20mm	\$0.87	\$0.91	\$0.95
11-6175	Extra Coarse	Brown	3mm	23mm	\$0.87	\$0.91	\$0.95
11-6176	Hard	Blue	3mm	23mm	\$0.87	\$0.91	\$0.95
11-6177	Medium	Gray	3mm	23mm	\$0.87	\$0.91	\$0.95
11-6178	Fine	Reddish Brown	3mm	23mm	\$0.87	\$0.91	\$0.95
11-6179	Extra Fine	Green	3mm	23mm	\$0.87	\$0.91	\$0.95
11-6171	51-Piece Kit Assortment				\$23.87	\$24.91	\$25.95
11-6181	51-Piece Kit Assortment				\$23.87	\$24.91	\$25.95
43-1300	2mm Mandrel (1/8" Arbor hole)				\$4.46	\$4.66	\$4.85
43-1301	3mm Mandrel (1/8" Arbor hole)				\$4.77	\$5.18	\$5.75







**UNMOUNTED AIRFLEX POLISHERS**

Excellent for all types of metal including titanium, unmounted Airflex polishers provide a more flexible wheel than standard, heatless wheels. These new wheels are made with tiny air voids uniformly distributed through the wheel, providing a cool-running, flexible polishing wheel. These Airflex wheels aggressively remove material. Use mandrel 43-1280 or 43-1282.



Order #	Description	12+	6+	1+
11-6172	31-Piece Airflex Kit	\$20.75	\$21.65	\$22.55



**Order # 11-61930**

**SQUARE-EDGE WHEEL**

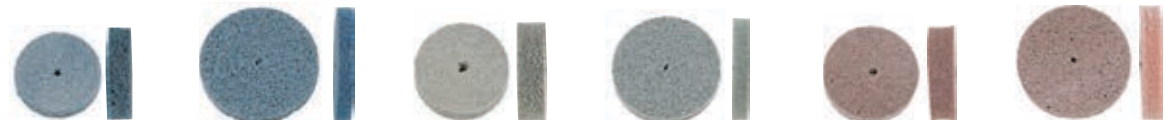

Color	Blue	Blue	Gray	Gray	Pink	Pink
OD	5/8"	7/8"	5/8"	7/8"	5/8"	7/8"
Thickness	1 1/16"	1/8"	1/8"	1/8"	1/8"	1/8"
Grade	Coarse	Coarse	Medium	Medium	Fine	Fine
12+	\$0.78	\$0.78	\$0.72	\$0.72	\$0.72	\$0.72
6+	\$0.82	\$0.82	\$0.77	\$0.77	\$0.77	\$0.77
1+	\$0.85	\$0.85	\$0.85	\$0.85	\$0.85	\$0.85



**CERAMIC POLISHING WHEELS**

Ceramic-infused polishing wheels for smoothing and polishing precious metals, including platinum, gold, silver, and titanium. Available in six color-coded grits, these wheels work faster and last longer than other polishers. Use with mandrel 43-1280.



Order #	Grit	Color	OD x Thickness	12+	6+	1+
11-6091	1500	White	7/8" x 1/8"	\$11.41	\$11.90	\$12.40
11-6092	1000	Gray	7/8" x 1/8"	\$11.41	\$11.90	\$12.40
11-6093	500	Orange	7/8" x 1/8"	\$11.41	\$11.90	\$12.40
11-6094	320	Violet	7/8" x 1/8"	\$11.41	\$11.90	\$12.40
11-6095	180	Green	7/8" x 1/8"	\$11.41	\$11.90	\$12.40
11-6096	120	Blue	7/8" x 1/8"	\$11.41	\$11.90	\$12.40



**STULLER PREMIUM SWISS STEEL POLISHERS**

The most abrasive and toughest polishers for stainless steel and chrome-cobalt alloys. Available in three grits: coarse, medium, and fine. Available in unmounted only. Made in Switzerland.

**Order # 11-63500**

**BROWN**



OD	7/8"	1/4"	7/8"	1/4"	7/8"
Thickness	1/8"	7/8"	1/8"	7/8"	1/8"
Grade	Coarse	Medium	Medium	Fine	Fine
Shape	Square-Edge	Cylinder	Square-Edge	Cylinder	Square-Edge
12+	\$0.74	\$0.74	\$0.74	\$0.74	\$0.74
6+	\$0.77	\$0.77	\$0.77	\$0.77	\$0.77
1+	\$0.80	\$0.80	\$0.80	\$0.80	\$0.80



**STULLER PREMIUM PLATINUM AND GEMSTONE POLISHERS**

Premium polishers for platinum and gemstones. Three-step process produces a high gloss luster on platinum. Made in Switzerland.

**Order # 11-63600**



**WHITE**

Eliminates Scratches

OD	1/4"	1/4"	7/8"	7/8"
Thickness	5/8"	1 1/16"	1/8"	1/8"
Shape	Point	Bullet	Knife-Edge	Square-Edge
12+	\$1.70	\$1.70	\$0.92	\$0.92
6+	\$1.78	\$1.78	\$0.96	\$0.96
1+	\$1.85	\$1.85	\$1.00	\$1.00



**PINK**

Repair Structure

OD	1/4"	1/4"	1/4"	7/8"	7/8"
Thickness	7/8"	5/8"	1 1/16"	1/8"	1/8"
Shape	Cylinder	Point	Bullet	Knife-Edge	Square-Edge
12+	\$0.92	\$1.70	\$1.70	\$0.92	\$0.92
6+	\$0.96	\$1.78	\$1.78	\$0.96	\$0.96
1+	\$1.00	\$1.85	\$1.85	\$1.00	\$1.00



**GRAY**

High Gloss Finish

OD	1/4"	5/8"	5/8"	7/8"	7/8"	1/4"
Thickness	1 1/16"	1/8"	1/8"	1/8"	1/8"	5/8"
Shape	Point	Bullet	Knife-Edge	Square-Edge	Knife-Edge	Square-Edge
12+	\$1.70	\$1.70	\$1.70	\$1.70	\$0.92	\$0.92
6+	\$1.78	\$1.78	\$1.78	\$1.78	\$0.96	\$0.96
1+	\$1.85	\$1.85	\$1.85	\$1.85	\$1.00	\$1.00

**CHROME ALLOYS, STAINLESS STEEL, AND TITANIUM POLISHERS**

Designed for use on high-strength alloys for preparing and high-gloss polishing. Controllable handling with a high level of material removal. Hard, flexible synthetic rubber binder.



**Order # 11-65300**



**BLUE**

OD	7/8"	7/8"	7/8"	1/4"	1/4"	5/8"	7/8"	7/8"	7/8"	1/4"	1/4"	5/8"
Thickness	1/8"	1 1/16"	3/16"	7/8"	1 1/16"	7/8"	1/8"	1/16"	3/16"	7/8"	1 1/16"	7/8"
Grade	Medium	Medium	Medium	Medium	Medium	Medium	Fine	Fine	Fine	Fine	Fine	Fine
Shape	Square-Edge	Square-Edge	Square-Edge	Cylinder	Point	Square-Edge	Square-Edge	Square-Edge	Knife-Edge	Cylinder	Point	Square-Edge
12+	\$0.63	\$0.63	\$0.63	\$0.63	\$1.12	\$1.16	\$0.63	\$0.63	\$0.63	\$0.63	\$1.12	\$1.16
6+	\$0.72	\$0.72	\$0.72	\$0.72	\$1.26	\$1.31	\$0.72	\$0.72	\$0.72	\$0.72	\$1.26	\$1.31
1+	\$0.90	\$0.90	\$0.90	\$0.90	\$1.40	\$1.45	\$0.90	\$0.90	\$0.90	\$0.90	\$1.40	\$1.45

**CYLINDER POLISHING KIT**

Specially designed cylinders for polishing inside rings. Eliminates the use of sand paper rolls. 14-piece kit includes: coarse 180 (blue), fine 220 (gray), extra-fine 800 (green), high-shine 1200 (pink), and two inside ring mandrels (1 - 43-1288 and 1 - 43-1289).



Order #	Description	12+	6+	1+
11-6620	Starter Kit	\$21.62	\$22.56	\$23.50



Order #	11-8180	11-8182	11-8184	11-8186
OD	1/2"	1/2"	1/2"	1/2"
Thickness	1/8"	1/2"	1/2"	1/2"
Grit	180 Coarse	220 Coarse	800 Coarse	1200 High Shine
12+	\$5.35	\$5.35	\$5.35	\$5.35
6+	\$5.81	\$5.81	\$5.81	\$5.81
1+	\$6.45	\$6.45	\$6.45	\$6.45

**JUMBO CYLINDER MANDRELS**

Nickel-plated small wheel mandrels.

Suggested Mandrels	Shank	12+	6+	1+
A 43-1288	Stainless Steel 3/32"	\$2.70	\$2.93	\$3.25
B 43-1289	Stainless Steel 1/8"	\$2.70	\$2.93	\$3.25

**PREMIUM RUBBER POLISHERS**

Rubber polishers used for gold and other precious and semi-precious alloys. Made in Switzerland.



Order #11-63000



**BROWN**  
Pre-Polish

OD	1/4"	1/4"	5/8"	7/8"	5/8"	5/8"	1/8"
Thickness	5/8"	1 1/16"	1/8"	1/16"	1/8"	1/2"	7/8"
Shape	Point	Bullet	Knife-Edge	Knife-Edge	Square-Edge	Cylinder	Square-Edge
12+	\$1.52	\$1.52	\$1.98	\$1.98	\$2.67	\$2.67	\$0.78
6+	\$1.58	\$1.58	\$2.06	\$2.06	\$2.78	\$2.78	\$0.82
1+	\$1.65	\$1.65	\$2.15	\$2.15	\$2.90	\$2.90	\$0.85



**GREEN**  
High Polish

OD	1/4"	5/8"	7/8"	5/8"	7/8"	7/8"
Thickness	5/8"	1/8"	1/16"	1/2"	1/16"	1/8"
Shape	Point	Knife-Edge	Knife-Edge	Cylinder	Square-Edge	Square-Edge
12+	\$1.66	\$2.12	\$1.96	\$2.67	\$0.78	\$0.78
6+	\$1.73	\$2.21	\$2.07	\$2.78	\$0.82	\$0.82
1+	\$1.80	\$2.30	\$2.30	\$2.90	\$0.85	\$0.85

OD	1/4"	5/8"	7/8"
Thickness	1 1/16"	1/8"	1/16"
Shape	Bullet	Square-Edge	Square-Edge
12+	\$1.56	\$1.56	\$1.56
6+	\$1.63	\$1.63	\$1.63
1+	\$1.70	\$1.70	\$1.70

**TITANIUM AND PLATINUM HIGH-PERFORMANCE POLISHING WHEELS**

High-performance polishing wheels available in a medium grit and an extra-fine grit for high-luster polishing. Made in Germany from the highest quality raw materials available. Use mandrels 43-1280 or 43-1282.



Order #11-62620

**GRAY**  
Medium



OD	7/8"	7/8"	1/8"	7/8"	7/8"	5/8"	5/8"
Thickness	1/8"	1/8"	1/8"	1/8"	1/8"	1/8"	1/8"
Shape	Square-Edge	Knife-Edge	Cylinder	Bullet	Cylinder	Square-Edge	Knife-Edge
12+	\$0.60	\$0.60	\$0.60	\$1.70	\$1.96	\$1.70	\$1.70
6+	\$0.63	\$0.63	\$0.63	\$1.78	\$2.07	\$1.78	\$1.78
1+	\$0.70	\$0.70	\$0.70	\$1.85	\$2.30	\$1.85	\$1.85

**LILAC**  
Extra Fine



OD	7/8"	7/8"	1/8"	5/8"	9/16"	5/8"	5/8"
Thickness	1/8"	1/8"	1 1/16"	1 1/16"	1/2"	1/8"	1/8"
Shape	Square-Edge	Knife-Edge	Cylinder	Bullet	Cylinder	Square-Edge	Knife-Edge
12+	\$0.60	\$0.60	\$0.60	\$1.70	\$1.96	\$1.70	\$1.70
6+	\$0.63	\$0.63	\$0.63	\$1.78	\$2.07	\$1.78	\$1.78
1+	\$0.70	\$0.70	\$0.70	\$1.85	\$2.30	\$1.85	\$1.85

**DIAMOND-IMPREGNATED POLISHING KIT**

Platinum diamond-impregnated polishing kit contains nine polishers. Long-lasting, high performance, rubber polishers create a high luster quickly and works especially well with platinum. These individual polishers are mounted and ready to use. One of each fineness of the point, disc, and square-edge polishers (11mm x 14mm) are included in the kit. Shanks are 3/32".

Order #11-62010

Item	Shape	OD	Thickness	12+	6+	1+
A	Square-Edge	7/16"	1/8"	\$10.40	\$10.85	\$11.30
B	Square-Edge	7/16"	3/16"	\$17.71	\$18.48	\$19.25
C	Point	3/16"	9/16"	\$10.40	\$10.85	\$11.30
D	Flex Disc	3/4"	1/16"	\$17.71	\$18.48	\$19.25
E	Square-Edge	7/16"	1/8"	\$10.40	\$10.85	\$11.30
F	Square-Edge	7/16"	3/16"	\$17.71	\$18.48	\$19.25
G	Point	3/16"	9/16"	\$10.40	\$10.85	\$11.30
H	Flex Disc	3/4"	1/16"	\$17.71	\$18.48	\$19.25
J	Square-Edge	1 1/2"	2"	\$10.40	\$10.85	\$11.30
K	Square-Edge	7/16"	3/16"	\$17.71	\$18.48	\$19.25
L	Point	3/16"	9/16"	\$10.40	\$10.85	\$11.30
M	Flex Disc	3/4"	1/16"	\$17.71	\$18.48	\$19.25

Kit Order #11-8099	12+	6+	1+
Non-Precious Metal Polishing Kit	\$32.08	\$36.09	\$40.10







**RUBY POWDER**

Intended for use with hand buffs, brushes, felts, and wood laps. Can be mixed with water or fine oil to form a 5000 grit polishing paste that will impart a high luster. The Ruby powder gives a high luster to platinum, gold, steel, precious stones, pearl, ivory, horn shell, and porcelain.

Order #	Description	Grit	12+	6+	1+
59-1039	High Shine Polishing Powder	5000	\$5.74	\$6.08	\$6.75

**GEM SHINE POLISHING WHEELS**

Polishing wheels designed for removing light surface scratches from soft stones such as onyx, cabochons, and opals. The Gem Shine wheels are impregnated with a polishing paste to provide scratch removal and a final polish on the stone's surface. Comes with five wheels and a reinforced mandrel.

Order #	Description	12+	6+	1+
11-6065	Gem Shine Kit	\$20.78	\$22.01	\$24.45

**MIRACLE GOLD SILICONE WHEEL**

The industries absolute finest rubberized abrasive for final polishing of gold and semi-precious metals. Eliminates the need for rouge. Use mandrel 43-1281.

Item	Order #	Shape	OD	Thickness	12+	6+	1+
A	11-6072	Knife-Edge	7/8"	1/8"	\$17.39	\$18.14	\$18.90
B	11-6074	Square-Edge	7/8"	1/8"	\$17.39	\$18.14	\$18.90

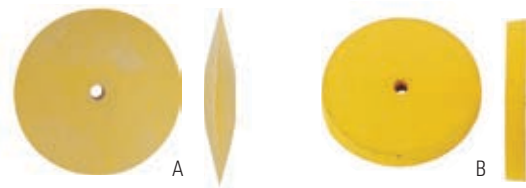

**PUMICE POLISHERS**

Excellent for use on prong and bezel finishing with set stones. Provides safe polishing around precious and synthetic stones. Contains a silicone binder, which provides more durability.

Order #11-62440

**GOLD**  
Medium

OD	Thickness	Shape	12+	6+	1+
5/8"	1/8"	Square-Edge	\$0.72	\$0.77	\$0.85
7/8"	1/8"	Square-Edge	\$0.60	\$0.68	\$0.85
7/8"	1/8"	Knife-Edge	\$0.72	\$0.77	\$0.85
5/8"	1/16"	Knife-Edge	\$1.66	\$1.76	\$1.95
1/4"	1/16"	Point	\$1.66	\$1.76	\$1.95
5/8"	1/8"	Square-Edge	\$1.66	\$1.76	\$1.95
5/8"	1/8"	Knife-Edge	\$0.72	\$0.77	\$0.85

**GRAY**  
Fine

OD	Thickness	Shape	12+	6+	1+
1/2"	1/8"	Square-Edge	\$0.72	\$0.77	\$0.85
7/8"	1/8"	Square-Edge	\$0.60	\$0.68	\$0.85
5/8"	1/8"	Knife-Edge	\$0.72	\$0.77	\$0.85
7/8"	1/8"	Knife-Edge	\$0.60	\$0.68	\$0.85
1/4"	1 1/16"	Point	\$1.66	\$1.76	\$1.95
5/8"	1/8"	Square-Edge	\$1.66	\$1.76	\$1.95
5/8"	1/8"	Knife-Edge	\$1.66	\$1.76	\$1.95

**JEWELER'S PUMICE POLISHERS**

Rubberized pumice polishers provide a very fine result for finishing and a final polish for gold and semi-precious metals. Will not scratch stones. Extra-long lasting.

Order #11-62800

Item	Shape	OD	Thickness	12+	6+	1+
C	Square-Edge	5/8"	1/8"	\$0.98	\$1.04	\$1.15
D	Square-Edge	7/8"	1/8"	\$0.98	\$1.04	\$1.15
E	Knife-Edge	5/8"	1/8"	\$0.98	\$1.04	\$1.15
F	Knife-Edge	7/8"	1/8"	\$0.98	\$1.04	\$1.15

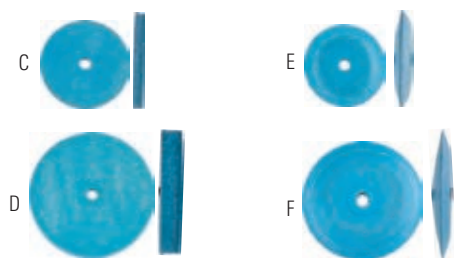

**SILICONE PUMICE WHEELS**

Unique pumice wheel mixed with silicone to last longer than standard pumice wheels. Safe for use on soft stones. Use with mandrels 43-1280 or 43-1281.

Order #11-81640

Item	Shape	OD	Thickness	12+	6+	1+
A	Square-Edge	7/8"	1/8"	\$3.87	\$4.10	\$4.55
B	Square-Edge	5/8"	1/8"	\$3.87	\$4.10	\$4.55
C	Knife-Edge	7/8"	1/8"	\$3.87	\$4.10	\$4.55
D	Knife-Edge	5/8"	1/8"	\$3.78	\$4.10	\$4.55

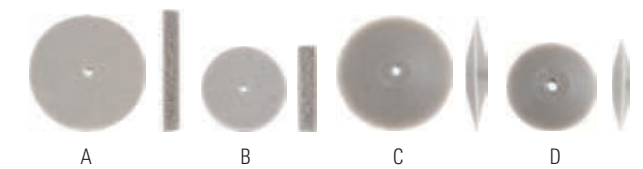

**ALL-IN-ONE POLISHERS**

Introducing a new breakthrough polishing line: these all-in-one polishers. Polish and shine in one step, touchup, and use for precious metals and stones. Long lasting and won't scratch stones. Unmounted. Use with mandrel 43-1281.

Item	Order #	Shape	OD	Thickness	12+	6+	1+
E	11-6600	Square-Edge	5/8"	1/8"	\$0.83	\$0.90	\$1.00
F	11-6601	Square-Edge	7/8"	1/8"	\$0.83	\$0.90	\$1.00
G	11-6602	Knife-Edge	5/8"	1/8"	\$0.83	\$0.90	\$1.00
H	11-6603	Knife-Edge	7/8"	1/8"	\$0.83	\$0.90	\$1.00

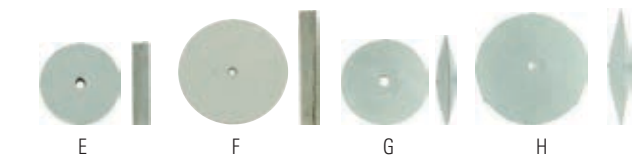

**STAINLESS STEEL MINIATURE MANDRELS**

Long-lasting, acrylic polishing rods give you a smooth finish in all of your hard-to-reach places. Excellent for use on non-precious and precious metals. Available in 2mm and 3mm diameters and five abrasive grades. Kits include 10 of each rod and a mandrel.

Item	Order #	Description	Shank Size	12+	6+	1+
J	43-1300	2mm Mandrel	3/32"	\$4.46	\$4.66	\$4.85
K	43-1301	3mm Mandrel	3/32"	\$4.77	\$5.18	\$5.75
L	43-1302	Mandrel	3/32"	\$1.45	\$1.58	\$1.75
M	43-1303	Reinforced	3/32"	\$1.45	\$1.58	\$1.75
N	43-1304	1/8" Standard	1/8"	\$1.66	\$1.80	\$2.00
P	43-1305	14mm Wheel	3/32"	—	—	\$1.85
Q	43-1306	8mm Wheel	3/32"	\$2.44	\$2.54	\$2.65



**NICKEL-PLATED MINIATURE MANDRELS**

Nickel-plated small wheel mandrels.

Item	Order #	Description	Shank Size	12+	6+	1+
R	43-1280	Reinforced Screw Mandrel	3/32"	\$0.94	\$0.99	\$1.10
S	43-1281	Standard Screw Mandrel	3/32"	\$0.77	\$0.88	\$1.10
T	43-1282	Heavy Duty Mandrel	3/32"	\$1.51	\$1.72	\$2.15
U	43-1283	1/8" Mandrel (1/8" shank with one silver cap for 1/8" and 1/4" thick wheels)	1/8"	\$1.48	\$1.67	\$1.85
V	43-1286	Stainless Steel	3/32"	\$0.77	\$0.88	\$1.10
W	43-1284	3/8" Crew Stainless Steel	3/32"	\$0.68	\$0.72	\$0.80
X	43-1288	Stainless Steel	3/32"	\$2.70	\$2.93	\$3.25
Y	43-1289	Stainless Steel	1/8"	\$2.70	\$2.93	\$3.25
Z	10-7050	Snap-On Mandrel	3/32"	\$1.74	\$1.89	\$2.10



**SPLIT MANDRELS FOR HANDPIECES**

Emery paper is wrapped around this mandrel and used for polishing smaller pieces.

Item	Order #	Description	Length	Shank Size	12+	6+	1+
AA	11-3009	Tapered	2 1/4"	3/32"	\$1.40	\$1.58	\$1.75
AB	11-3010	Slim	2 1/4"	3/32"	\$1.37	\$1.49	\$1.65



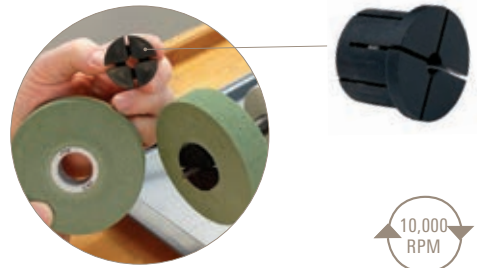

**TAPERED SPINDLE ADAPTERS**

This tapered spindle adapter is to be used on six-inch wheels with center holes that measure one inch.

Order #	Hole ID	12+	6+	1+
10-8208	1"	\$5.33	\$5.56	\$5.79



**EXL II WHEELS**

This wheel is a more aggressive wheel than the light deburring wheel. Excellent for rapid removal of sprues, parting lines, and fire scale. Wheels are 6" x 1" and have a 1" center hole. Be sure to order the correct adapter to fit your size motor shaft.

Order #	Grade	OD	Thickness	Hole ID	12+	6+	1+
10-8128	Medium	6"	1"	1"	\$63.34	\$66.10	\$68.85
10-8127	Fine	6"	1"	1"	\$68.03	\$70.99	\$73.95



**LIGHT DEBURRING WHEELS**

These light deburring wheels have been the #1 choice of jewelry manufacturers for years. Excellent for sprue removal, wheels are 6" in diameter and have a 1" center hole. Flanges are not included. 1" wheel adapter. Two pieces used for wheels with 1" center hole. Order wheel adapter to fit your shaft diameter.

Order #	Grade	OD	Thickness	Hole ID	12+	6+	1+
10-8182	Medium	6"	1"	1"	\$61.13	\$63.79	\$66.45
10-8181	Fine	6"	1"	1"	\$56.17	\$58.61	\$61.05



**STULLER ABRASIVE CLOTH FLAP WHEELS**

Use for light deburring when the casting is not so advanced and scarred. Leaves a typical deep straight mark of the abrasive cloth on the surface, masked by the satin pattern of the abrasive.

**Order # 10-70600**

Grit	OD	Thickness	12+	6+	1+
120	4 1/2"	1 1/8"	\$14.58	\$15.44	\$17.15
180	4 1/2"	1 1/8"	\$14.58	\$15.44	\$17.15
240	4 1/2"	1 1/8"	\$14.58	\$15.44	\$17.15
280	4 1/2"	1 1/8"	\$14.58	\$15.44	\$17.15
320	4 1/2"	1 1/8"	\$14.58	\$15.44	\$17.15
400	4 1/2"	1 1/8"	\$14.58	\$15.44	\$17.15



**ALUMINUM-OXIDE FLAP WHEELS**

The most popular item in the jewelry world is used for every kind of satin finishing pattern from the roughest (Grit A/Coarse) to the finest (Grit/Ultra-Fine).

**Order # 10-70700**

Material	Grade	OD x Thickness	12+	6+	1+
Scotch Brite	Coarse	4" x 1"	\$9.73	\$10.31	\$11.45
Scotch Brite	Medium	4" x 1"	\$9.73	\$10.31	\$11.45
Scotch Brite	Fine	4" x 1"	\$9.73	\$10.31	\$11.45

**Order # 10-70740**

Material	Grade	OD x Thickness	12+	6+	1+
Aluminum Oxide	Extra Fine	4" x 1"	\$9.73	\$10.31	\$11.45
Aluminum Oxide	Fine	4" x 1"	\$9.73	\$10.31	\$11.45
Aluminum Oxide	Super Fine	4" x 1"	\$9.73	\$10.31	\$11.45
Aluminum Oxide	Ultra-Fine	4" x 1"	\$9.73	\$10.31	\$11.45



**CLEAN AND FINISH BUFFS**

High-stretch, clean and finish buffs provide a fast, consistent, and beautiful satin finish. These 1/4" thick discs can be stacked to get the thickness you need.

**Order # 10-81200**

Grade	OD	12+	6+	1+
Medium	4"	\$2.48	\$2.59	\$2.70
Fine	4"	\$2.12	\$2.21	\$2.30
Extra Fine	4"	\$2.16	\$2.26	\$2.35
Medium	6"	\$4.19	\$4.37	\$4.55
Fine	6"	\$3.17	\$3.31	\$3.45



**UNMOUNTED AIRFLEX POLISHING WHEELS**

These new wheels are made with tiny air voids uniformly distributed throughout the wheel. This provides a cool running, flexible polishing wheel excellent for use on precious alloys, platinum, titanium, and stainless steel. Use with wheel mandrel 34-2013 and 34-2014.

**Order # 11-62550**

Item	Grade	OD	Thickness	ID	12+	6+	1+
A	Coarse	4"	5/8"	1/4"	\$18.77	\$19.58	\$20.40
B	Medium	4"	5/8"	1/4"	\$18.77	\$19.58	\$20.40
C	Fine	4"	5/8"	1/4"	\$18.77	\$19.58	\$20.40

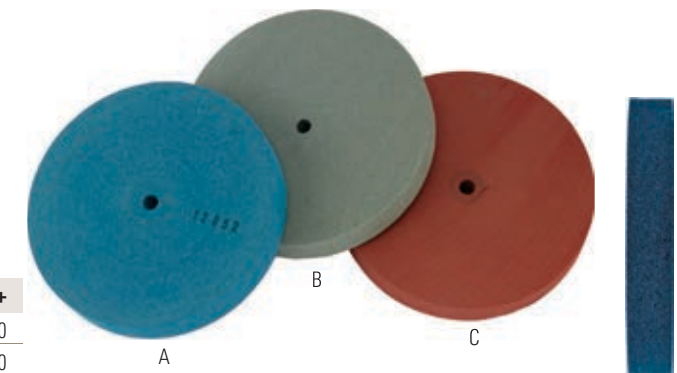





**PRIMO® FLAP BRUSH**

Quality abrasive ideal for creating satin finishes.

**Order #10-8321**

Color	OD	Thickness	ID	Grit	12+	6+	1+
Brown	5"	1"	¼"	280	\$18.72	\$19.54	\$20.35
Purple	5"	1"	¼"	400	\$18.72	\$19.54	\$20.35
Green	5"	1"	¼"	800	\$18.72	\$19.54	\$20.35
Gray	5"	1"	¼"	1000	\$18.72	\$19.54	\$20.35



**PRIMO® BLENDING AND CONVOLUTED WHEELS**

Quality abrasive wheel made from silicon carbide. Ideal for blending, deburring, and pre-polishing.

**Order #10-8322**

Color	OD	Thickness	ID	Grit	12+	6+	1+
Maroon	4"	1"	¼"	320	\$27.51	\$28.70	\$29.90
Green	4"	1"	¼"	400	\$27.51	\$28.70	\$29.90
Gray	4"	1"	¼"	800	\$27.51	\$28.70	\$29.90

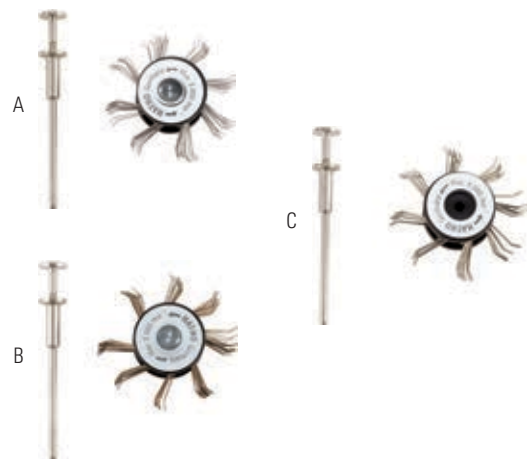

**MINIMAT BRUSH WITH MANDREL**

A. The .3mm Minimats brush allows you to quickly put a fine textured finish on bands or other fine jewelry.

B. The .45mm Minimats brush allows you to quickly put a medium textured finish on bands or other fine jewelry.

C. The .6mm Minimats brush allows you to quickly put a coarse textured finish on bands or other fine jewelry.

**Order #11-7100**

Item	Description	12+	6+	1+
A	.3mm	\$36.81	\$38.97	\$43.30
B	.45mm	\$36.81	\$38.97	\$43.30
C	.6mm	\$36.81	\$38.97	\$43.30



**MINIMAT BRUSH SET WITH MANDREL**

The Minimats brush set comes complete with one wheel, one mandrel, and one set of each size of pins. Use this set to create fine, medium, and coarse textures on bands or other fine jewelry.

Order #	Description	12+	6+	1+
<b>11-7101</b>	.3, .45, and .6mm	\$56.95	\$60.30	\$67.00



## Stuller First® Loyalty Program

EXCELLENT FLAT-RATE SHIPPING PLUS ADDITIONAL BENEFITS

Joining Stuller First is a smart decision. You can save money on shipping, increase profitability, and simplify doing business. Benefits include —

- A Stuller First dedicated team on hand for all your post order needs
- Exclusive promotions and special purchasing opportunities
- Access to our professional online image archive for your marketing and advertising needs
- Automated reorders for your basic stock
- A monthly e-newsletter that keeps you up to date on new benefits and opportunities

Visit [Stuller.com/StullerFirst](http://Stuller.com/StullerFirst) or call the experts at 800-877-7777 to get signed up.



# ADHESIVES



### SUPER NEW-GLUE®

Super strength cyanoacrylate adhesive sets and cures rapidly at room temperature. New-Glue bonds rubber, metal, glass, and plastic. Dries clear and has an excellent resistance to chemicals and low temperatures. Made in the USA.

Order #	Size	Drying Time	12+	6+	1+
12-2120	3 g tube	20-30 seconds	\$1.70	\$1.85	\$2.05



### VIGOR® SUPER GLUE

Strong cyanoacrylate adhesive capable of bonding a combination of metals, plastic, rubber, ceramic, and glass. Sets and cures rapidly at room temperature. Requires no surface treatment. Bond is colorless and transparent.



Order #	Size	Drying Time	12+	6+	1+
12-2117	1.67 oz.	45-60 seconds	\$9.34	\$9.74	\$10.15
12-2118	1.66 oz.	10-20 seconds	\$8.88	\$9.26	\$9.65



### 3M® QUICK-FIX ADHESIVE

3M quick-fix adhesive instantly bonds rubber, plastic, and metal.

Order #	Size	Drying Time	12+	6+	1+
12-2125	1.34 oz.	1 minute	\$22.36	\$23.33	\$24.30



### G-S HYPO TUBE CEMENT

This precision applicator allows you to apply cement inside beads without creating a mess. Recommended for all illusion designs that use plastic, ceramic, glass, and metal beads. Dries clear with no mess. Will not bond fingers.

Order #	Size	Drying Time	12+	6+	1+
12-2050	½ oz tube	10-20 seconds	\$5.80	\$6.05	\$6.30

### TWO-PART JEWELRY EPOXY

Use for making and repairing jewelry. Also works on metal, wood, glass, stones, crystal, and ceramic. Clear, non-shrink formula is resistant to most chemicals. Two-part epoxy sets in just five minutes and withstands temperatures up to 175°F. One fluid ounce total. Dries clear with a two-year shelf life.

Order #	Size	Drying Time	12+	6+	1+
12-0451	2- ½ oz tubes	5 minutes	\$3.31	\$3.46	\$3.60



### 3M® SUPER-STRENGTH ADHESIVE

3M super strength adhesive has a drying time of 30 seconds.

Order #	Size	Drying Time	12+	6+	1+
12-2122	2- ½ oz tubes	30 seconds	\$3.54	\$3.70	\$3.85



### SUPER GLUE QUICK FIX

This is the best product for general use. It works on metal, china, glass, and plastic. Cures light yellow. One part hardener and one part resin. Strength is 1200 psi.

Item	Order #	Size	Drying Time	12+	6+	1+
A	12-2137	2- ½ oz tubes	5 minutes	\$2.47	\$2.61	\$2.90

### SUPER GLUE GEL

Precision applicator works best for a continuous stream of glue. Works on metal, rubber, and plastic. Self-piercing tube.

Item	Order #	Size	Drying Time	12+	6+	1+
B	12-2111	0.07 oz tube	10-20 seconds	\$2.12	\$2.21	\$2.30

### FUTURE GLUE GEL

Bonds instantly, faster than other super glues. Works on multiple surfaces including oily or dirty surfaces. Self-piercing tube. Works on porous and non-porous surfaces including metal, cardboard, and corkboard.

Item	Order #	Size	Drying Time	12+	6+	1+
C	12-2112	2 g tube	10-20 seconds	\$2.12	\$2.21	\$2.30

### SUPER GLUE QUICK FIX

Original formula super glue bonds instantly. Precision applicator extender tip drops super glue into tight spots. Works best on clean, non-porous surfaces including metal, rubber, and plastic.

Item	Order #	Size	Drying Time	12+	6+	1+
D	12-2114	2 g tube	10-20 seconds	\$1.84	\$2.07	\$2.30



A



B



C



D



A

**BONDINI® EVERYTHING GEL**

Fills gaps and cracks and penetrates through grease and oil to form a strong bond. Bonds rubber, stone, plastic, wood, metal, and tile.

Item	Order #	Size	Drying Time	12+	6+	1+
A	12-2113	4 g bottle	10-20 seconds	\$2.47	\$2.61	\$2.90



B

**QUICK SETTING EPOXY**

Bonds vertical surfaces and fills gaps. Works best on rubber, carpet, wood, and plastic. Cures cream color or can be tinted to desired color. Strength is 1200 psi.

Item	Order #	Size	Drying Time	12+	6+	1+
B	12-2138	0.14 oz tubes	5 minutes	\$1.91	\$2.03	\$2.25



C

**QUICK SETTING EPOXY**

Best product for general use. Works best on metal, china, glass, and plastic. Cures light yellow. Strength is 1200 psi.

Item	Order #	Size	Drying Time	12+	6+	1+
C	12-2136	1 oz tube	5 minutes	\$3.28	\$3.69	\$4.10



**BEADALON® BEAD STRINGING GLUE**

Great for use on silk, Nymo, nylon, Elasticity, Elonga, and other stringing materials. Beadalon designers bead stringing glue has a fine-tip applicator, perfect for getting the glue exactly where you need it. No-clog cap keeps the applicator always ready.

Order #	Size	12+	6+	1+
12-2051	10 ml tube	\$4.00	\$4.23	\$4.70



**VIGOR® SUPER GLUE**

Exceptionally effective for stone and pearl settings. Strong ethyl adhesive bonds any combination of metal, plastic, rubber, ceramic, or glass. Sets in 45-60 seconds and dries colorless and transparent.

Order #	Size	Drying Time	12+	6+	1+
12-2115	0.07 oz (2 g)	45-60 seconds	\$2.12	\$2.21	\$2.30

**BEADFIX™ SUPERFAST ADHESIVE**

This adhesive is ideal for adhering glass, stone, metal, plastic, wood, and most other types of beads. Quick adhesion; allow 24 hours dry time for maximum strength. Precision applicators available with 3 gram BeadFix.

Order #	Description	Size	12+	6+	1+
12-2121	Adhesive Glue	0.10 oz (3 g)	\$5.82	\$6.17	\$6.85



**BEADALON® BEAD FIX GEL**

This adhesive is ideal for adhering glass, stone, metal, plastic, wood, and most other types of beads. BeadFix is unaffected by cold and heat and is water resistant. Quick setting, even on absorbent surfaces. When attaching end caps to memory wire, allow 24 hours drying time for maximum strength.

Order #	Description	Size	12+	6+	1+
12-2056	Adhesive Gel	0.43 oz (3 g)	\$6.16	\$6.53	\$7.25



**DEVCON® EPOXY 330 WATER CLEAR**

Excellent for attaching end caps to leather cord, the assembly of stones to metal findings, and mending broken glass and china. Hardens in one hour (approximately) at room temperature and 10 minutes under heat lamp at 200°F. Ideal where clarity is important. Refractive index is 1.3025, tensile strength neat 9,000 pounds with viscosity at 1,200 CPS. Drying Time: 1 hour (10 minutes with heat)

Item	Order #	Description	Size	12+	6+	1+
A	26-6009	Epoxy 220	2- ½ oz tubes	\$5.14	\$5.45	\$6.05
B	26-6010	Epoxy 330	2- ½ oz tubes	\$5.14	\$5.45	\$6.05



**TWO-PART JEWELRY EPOXY**

A high-grade clear synthetic rubber adhesive with superior adhesion characteristics that sets in 10 minutes. Works on all woods, metals, fiberglass, glass, leather, and reinforced plastics. May be used on high wear surfaces.

Order #	Size	12+	6+	1+
12-2135	3.7 oz tube	\$5.31	\$5.63	\$6.25



**DEVCON® EPOXY**

Devcon epoxy adhesive cures and joins materials together by a chemical reaction between the resin and hardener. This reaction results in a high-strength bond that is resistant to most chemicals. Use epoxy adhesive for household, industrial, crafts, or for any job that requires a high-strength, high-quality bond. Works on metal, wood, concrete, glass, ceramics, china, and much more. Sets in five minutes and dries clear with strength up to 1,500 psi.

Item	Order #	Size	Drying Time	12+	6+	1+
C	12-2131	2- ½ oz tubes	5 minutes	\$3.87	\$4.10	\$4.55
D	12-2132	2- ½ oz tubes	10-20 minutes	\$4.80	\$5.09	\$5.65



Adhesives

Adhesives





**GRIFFITH ACETONE**

This quick-drying solvent dissolves most lacquers and cements.

Order #	Description	Size	12+	6+	1+
54-8000	Acetone Solvent	8 oz bottle	\$6.81	\$7.10	\$7.40



**ATTACK GLUE-DISSOLVING COMPOUND**

Dissolves cured epoxy and polyester resins. Cleans cured resins from metal, stone, glass, wood, undrilled pearls, quartz, coral, and many other materials. Do not use with plastic, amber, or amelite.

Order #	Description	Size	12+	6+	1+
38-3250	Dissolving Compound	8 oz can	\$9.48	\$9.89	\$10.30



**3M® HI-TACK ADHESIVE SPRAY**

3M® Hi-Tack 76 spray adhesive forms a very strong bond on many hard to bond materials such as polyethylene sheeting, rubber, fabric, felt, foil, plastics, glass, and other surfaces.

Order #	Drying time	Size	1+
12-3000	1 minute	18 oz can	\$26.80



**OPTICON FRACTURE SEALER**

The standard sealer for sealing stone fractures, this sealer is highly effective in penetrating surfaces. Depending on the stone and mineral content, some of the fractures will not permit an invisible seal.

Order #	Drying time	Size	12+	6+	1+
26-6008	1 Hour 15 minutes (1 hour with heat)	8 oz bottle	\$16.02	\$16.97	\$18.85

# Are You on BenchJeweler.com?



Don't miss out on all that BenchJeweler.com has to offer. It's a great place to learn from your peers, share information with your fellow jewelers, get special deals from Stuller, and much more.

**BenchJEWELER.com**  
powered by  STULLER



# BAGS AND ENVELOPES



### MINIGRIP® RED LINE™ BAGS

Premium zipper easily snaps open and zips securely shut with superior clarity that you can see. Red Line bags are packaged in convenient dispenser bag packaging. Remove a bag at a time through the mid-package opening or through the zipper at the top. Manufactured with 100% FDA-approved virgin LDPE and LLDPE resins, the reinforced zipper and side seams to keep bags from splitting when opened or filled. Volume pricing is available for boxes of 1000.

**Order # 90-0000** 2mm Thickness. Sold in Bags of 100

Size	2"×2"	2"×3"	3"×3"	3"×4"	3"×5"	4"×4"
50+	\$1.48	\$1.53	\$1.65	\$1.88	\$2.45	\$1.98
10+	\$1.62	\$1.68	\$1.82	\$2.06	\$2.70	\$2.17
1+	\$2.95	\$3.05	\$3.30	\$3.75	\$4.90	\$3.95

Size	4"×6"	4"×8"	5"×7"	6"×8"	8"×10"	10"×12"
50+	\$2.60	\$4.24	\$3.15	\$4.69	\$5.88	\$8.26
10+	\$2.86	\$4.54	\$3.47	\$5.03	\$6.30	\$8.85
1+	\$5.20	\$6.05	\$6.30	\$6.70	\$8.40	\$11.80

**Order # 90-0200** 4mm Thickness. Sold in Bags of 100

Size	2½"×3"	3"×4"	3"×5"	4"×6"	6"×6"	6"×8"
50+	\$2.94	\$3.54	\$4.17	\$5.36	\$6.69	\$7.84
10+	\$3.15	\$3.79	\$4.46	\$5.74	\$7.16	\$8.40
1+	\$4.20	\$5.05	\$5.95	\$7.65	\$9.55	\$11.20

Size	6"×9"	8"×10"	10"×10"	10"×13"
50+	\$9.49	\$12.32	\$15.65	\$22.93
10+	\$10.16	\$13.26	\$16.76	\$24.56
1+	\$13.55	\$17.60	\$22.35	\$32.75



### MINIGRIP® RED LINE™ WHITE BLOCK BAGS

**Order # 90-0100** 2mm Thickness. Sold in Bags of 100.

Size	2"×3"	3"×4"	3"×5"	4"×6"	5"×8"	6"×9"	8"×10"	9"×12"
50+	\$1.95	\$2.23	\$2.40	\$3.23	\$4.94	\$5.85	\$10.29	\$10.64
10+	\$2.15	\$2.45	\$2.64	\$3.55	\$5.29	\$6.26	\$11.03	\$11.40
1+	\$3.90	\$4.45	\$4.80	\$6.45	\$7.05	\$8.35	\$14.70	\$15.20

**Order # 90-0300** 4mm Thickness. Sold in Bags of 100.

Size	4"×6"	6"×9"
50+	\$6.72	\$10.85
10+	\$7.20	\$11.63
1+	\$9.60	\$15.50



### MINIGRIP® GREEN LINE™ BIODEGRADABLE BAGS

Ever wonder what happens to that poly bag when you throw it away. It will sit in a landfill for years before it starts to biodegrade. With new Minigrip Green Line bags, you no longer have to worry. Minigrip technology contains an innovative bio-resin additive found to be biodegradable (ASTM D5511) thus drastically reducing the plastic's landfill life. Every part of the bag is biodegradable. It features the same great performance of a Red Line Bag but is biodegradable. Made of low-density polyethylene (LDPE).



**Order # 90-1000** 2mm Thickness. Sold in Bags of 100

Size	2"×2"	2"×3"	3"×4"	4"×6"	5"×7"	6"×9"	9"×12"
50+	\$1.28	\$1.50	\$2.03	\$2.63	\$3.70	\$5.25	\$8.60
10+	\$1.40	\$1.65	\$2.23	\$2.89	\$4.07	\$5.78	\$9.46
1+	\$2.55	\$3.00	\$4.05	\$5.25	\$7.40	\$10.50	\$17.20

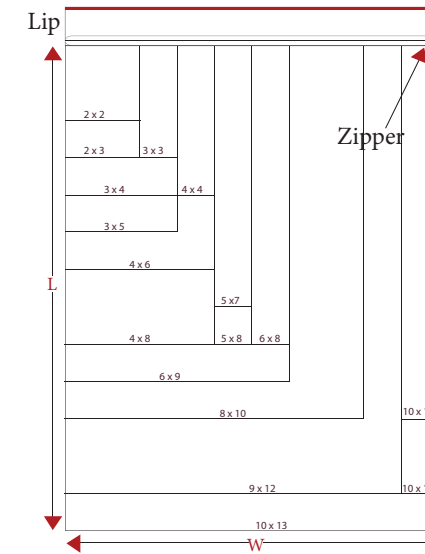

Width × Length resealable bags are measured without the zipper included.



Bags are measured width by length. Width is the outside dimension, Length is measured from the bottom of the zipper to the bottom of the bag. Due to reinforced side seals, bag openings are approximately ½" less than their listed width.

### CORROSION INTERCEPT CLEAR POLY ZIP-LOCK BAGS

Corrosion Intercept® clear poly zip-lock bags provide effective tarnish protection for metals. When the copper color turns black, it's time to change the intercept package. Protects items for up to 3 years.

Order #	W×L	Quantity	12+	6+	1+
61-1331	2"×3"	1 pack of 20	\$4.08	\$4.32	\$4.80
61-1331	2"×3"	50 pack of 20	\$127.54	\$135.05	\$150.05
61-1332	4"×4"	1 pack of 20	\$6.00	\$6.00	\$6.00
61-1333	4"×6"	1 pack of 20	\$5.40	\$5.72	\$6.35
61-1335	4"×4"	1 pack of 20	\$5.48	\$5.81	\$6.45
61-1336	6"×6"	1 pack of 20	\$7.31	\$7.74	\$8.60

Dual Compartment



### STATIC INTERCEPT NON-ABRASIVE ANTI-TARNISH STRIPS/TABS

The same technology used by NASA, the Guggenheim Museum and jewelry manufacturers worldwide.

- Provides protection from tarnish for up to 12 months
- Does not leave deposits on items it protects
- Nontoxic, non-abrasive, and will not scratch or harm metals or gemstones
- Before placing item in pouch, be sure item is clean, dry, and free of fingerprints and deposits

Order #	Description	W×L	12+	6+	1+
11-0651	Strip (20 pack)	2"×7"	\$3.65	\$3.96	\$4.40
11-0652	Tab (50 pack)	1"×1"	\$2.95	\$3.20	\$3.55





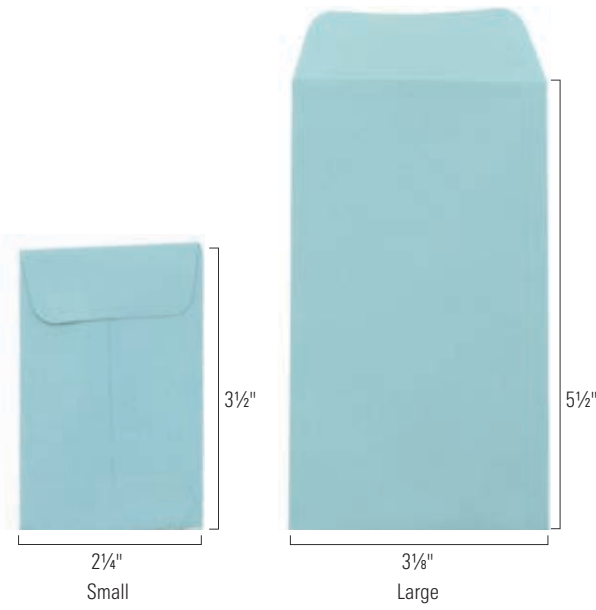

**BLANK JOB ENVELOPES**

Available in two sizes and five colors, these handy envelopes identify your work and help prevent misdirected orders. Gummed flaps allow for easy closing and reopening. Sold in packs of 500.



Order #	Description	WxL	12+	6+	1+
61-1595	#1 Kraft	2 1/4" x 3 1/2"	\$18.05	\$18.05	\$18.05
61-1596	#1 White	2 1/4" x 3 1/2"	\$18.05	\$18.05	\$18.05
61-1597	#1 Canary	2 1/4" x 3 1/2"	\$18.05	\$18.05	\$18.05
61-1598	#1 Light Green	2 1/4" x 3 1/2"	\$18.05	\$18.05	\$18.05
61-1599	#1 Light Blue	2 1/4" x 3 1/2"	\$18.05	\$18.05	\$18.05
61-1600	#5 Kraft	3 1/8" x 5 1/2"	\$23.25	\$23.25	\$23.25
61-1601	#5 White	3 1/8" x 5 1/2"	\$23.25	\$23.25	\$23.25
61-1602	#5 Canary	3 1/8" x 5 1/2"	\$23.25	\$23.25	\$23.25
61-1603	#5 Light Green	3 1/8" x 5 1/2"	\$23.25	\$23.25	\$23.25
61-1604	#5 Light Blue	3 1/8" x 5 1/2"	\$23.25	\$23.25	\$23.25

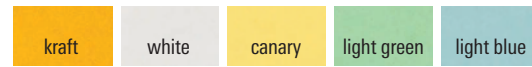

**TRIPLE-DUTY REPAIR ENVELOPES**

Printed on standard kraft paper, each numbered envelope has two detachable stubs with corresponding numbers: one for the customer and one for filing. Measures 3 1/8" x 5 3/4". Sold in packs of 1,000.

Order #	Description	Envelope #	12+	6+	1+
61-1510	Repair Envelope	1-1000	\$40.26	\$42.09	\$45.75
61-1520	Repair Envelope	1001-2000	\$40.26	\$42.09	\$45.75
61-1530	Repair Envelope	2001-3000	\$40.26	\$42.09	\$45.75
61-1540	Repair Envelope	3001-4000	\$40.26	\$42.09	\$45.75
61-1550	Repair Envelope	4001-5000	\$40.26	\$42.09	\$45.75
61-1555	Repair Envelope	5001-6000	\$40.26	\$42.09	\$45.75
61-1556	Repair Envelope	6001-7000	\$40.26	\$42.09	\$45.75
61-1557	Repair Envelope	7001-8000	\$40.26	\$42.09	\$45.75
61-1558	Repair Envelope	8001-9000	\$40.26	\$42.09	\$45.75
61-1559	Repair Envelope	9001-10000	\$40.26	\$42.09	\$45.75

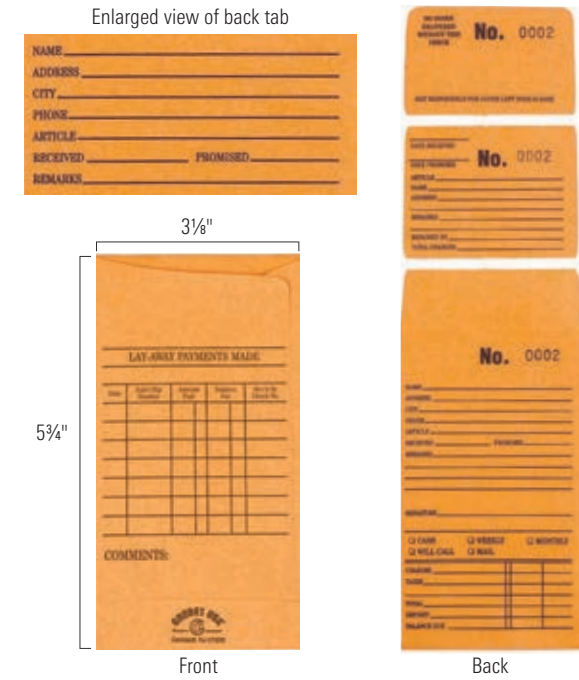

**FORMS**

Keep your jewelry repairs, watch repairs, and appraisals in order with these convenient forms.

Order #	Description	WxL	12+	6+	1+
61-1630	3-Part Jewelry Repair Forms (Box of 500)	4 1/2" x 6 1/2"	\$79.85	\$79.85	\$79.85
61-1635	3-Part Watch Repair Forms (Box of 500)	4 1/2" x 6 1/2"	\$79.85	\$79.85	\$79.85
61-1655	Appraisal Form (Pack of 100)	8 1/2" x 11"	\$24.15	\$25.20	\$26.25
61-1660	Zip Bag with Pouch (Box of 100)	5" x 6 1/2"	\$91.95	\$95.95	\$99.95
61-1710	Appraisal Forms with Envelopes (Box of 50)	8 1/2" x 11"	\$26.91	\$28.08	\$29.25



Appraisal Form (Pack of 100)



Zip Bag with Pouch (Box of 100)

Jewelry Form Close-Up

Watch Form Close-Up

**ACRYLIC ENVELOPE ORGANIZER AND DIVIDERS**

Keep your repair orders neat and arranged with this handy repair envelope organizer. Made of clear, sturdy, acrylic, this organizer will fit conveniently on most work surfaces for easy storage and retrieval. Repair envelopes (61-1510 shown with A) not included.

Item Order #	Description	WxLxH	12+	12+	1+
A 61-1560	Acrylic Envelope Organizer	3 1/2" x 11" x 3 1/2"	\$17.78	\$18.58	\$20.20
B 61-1640	Repair Form Dividers	9" x 4"	\$77.00	\$80.50	\$87.50

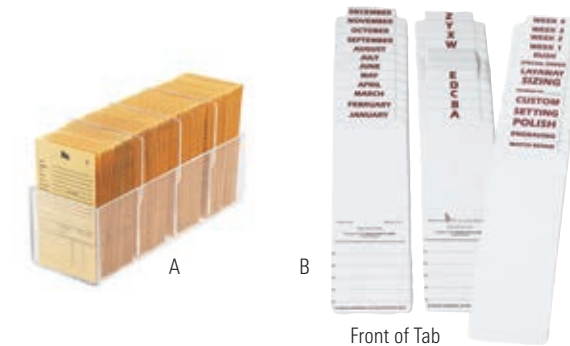

Front of Tab

**THANK YOU ENVELOPES**

Thank you envelopes. Sold in packs of 250.



Order #	Description	WxL	12+	6+	1+
61-1645	Blue	4" x 6 3/8"	\$35.95	\$35.95	\$35.95
61-1648	Black	4" x 6 3/8"	\$35.95	\$35.95	\$35.95
61-1647	Green	4" x 6 3/8"	\$35.95	\$35.95	\$35.95
61-1646	Burgundy	4" x 6 3/8"	\$35.95	\$35.95	\$35.95



**JEWELRY REPAIR ENVELOPES**

These repair order forms highlight specific areas to indicate issues for jewelry or watch repair. The triple form allows for individual copies for record keeping and customers.



Order #	Description	WxL	12+	6+	1+
61-1700	Repair Envelopes (Box of 500)	5 1/2" x 3 1/8"	\$24.29	\$25.39	\$27.60



Close-Up



# BATTERIES



## ENERGIZER® WATCH BATTERY STARTER KITS

### A. The Energizer® Deluxe Watch Battery Kit

Includes 200 assorted Energizer® batteries.

- 20 each of 377SP, 362SP, 379SP
- Five each of 371, 376, 370, 392, 397, 337, 394, 315, 303, 384, 391, 395, 357, 321, 317, 319, 362, 399, 373, 396, 389, 344, 390, ECR1216, ECR2025, ECR2016, ECR2032, ECR1025
- 60-drawer cabinet
- Watch tool kit and battery analyzer
- Battery size chart and cross reference guide
- Training booklet and store counter sign

### B. The Energizer® Basic Watch Battery Kit

includes 130 assorted Energizer® batteries.

- 20 each of 377SP, 364SP
- Five each of 379, 371, 376, 395, 357, 321, 317, 370, 319, 392, 362, 397, 399, 337, 373, ECR2016, ECR1216, ECR2032
- 60-drawer cabinet
- Watch tool kit and battery analyzer
- Battery size chart and cross reference guide
- Training booklet and store counter sign

Item	Order #	Description	1+
A	<b>EBAT:DELUXE:T</b>	Deluxe Watch Battery Kit	\$214.95
B	<b>EBAT:BASIC:T</b>	Basic Watch Battery Kit	\$145.95



### ENERGIZER® ELECTRIC WATCH BATTERY TESTER

Tests full range of silver, mercury, and coin lithium watch/electronic batteries. Compact, modern design is easy to use. Instructions on bottom of tester.

Item	Order #	Description	1+
A	<b>59-1000</b>	Energizer® Electric Watch Battery Tester	\$17.95
B	<b>59-3000</b>	Energizer® Watch Battery Analyzer	\$52.95



### WATCH BATTERIES (SPACE PACKS)

20

Order #	100+	25+	1+
<b>EBATSP 364-363</b>	\$5.92	\$6.13	\$7.05
<b>EBATSP 371-370</b>	\$11.59	\$12.01	\$13.80
<b>EBATSP 377-376</b>	\$7.73	\$8.00	\$9.20
<b>EBATSP 379</b>	\$10.34	\$10.71	\$12.31
<b>EBATSP 395-399</b>	\$11.26	\$11.66	\$13.40

### ENERGIZER®-SILVER OXIDE BATTERIES (INDIVIDUAL)

Order #	100+	25+	1+
<b>EBAT 315</b>	\$0.91	\$0.94	\$1.08
<b>EBAT 317</b>	\$0.98	\$1.02	\$1.17
<b>EBAT 319</b>	\$0.69	\$0.71	\$0.82
<b>EBAT 321</b>	\$0.64	\$0.66	\$0.76
<b>EBAT 341</b>	\$1.48	\$1.53	\$1.76
<b>EBAT 362-361</b>	\$0.56	\$0.58	\$0.67
<b>EBAT 364-363</b>	\$0.35	\$0.37	\$0.42
<b>EBAT 371-370</b>	\$0.58	\$0.60	\$0.69
<b>EBAT 373</b>	\$0.85	\$0.88	\$1.01
<b>EBAT 377-376</b>	\$0.39	\$0.40	\$0.46
<b>EBAT 379</b>	\$0.58	\$0.60	\$0.69
<b>EBAT 386-301</b>	\$1.36	\$1.41	\$1.62
<b>EBAT 393-309</b>	\$1.14	\$1.18	\$1.36
<b>EBAT 394-380</b>	\$0.94	\$0.97	\$1.12
<b>EBAT 395-399</b>	\$0.69	\$0.71	\$0.82
<b>EBAT 397-396</b>	\$0.69	\$0.71	\$0.82

### ENERGIZER®-LITHIUM BATTERIES (INDIVIDUAL)

Order #	100+	25+	1+
<b>EBAT 1216</b>	\$1.12	\$1.16	\$1.33
<b>EBAT 1220</b>	\$1.05	\$1.09	\$1.25
<b>EBAT 1616</b>	\$0.78	\$0.81	\$0.93
<b>EBAT 1620</b>	\$0.86	\$0.89	\$1.02
<b>EBAT 1632</b>	\$0.99	\$1.03	\$1.18
<b>EBAT 2016</b>	\$0.77	\$0.80	\$0.92
<b>EBAT 2025</b>	\$0.77	\$0.80	\$0.92
<b>EBAT 2032</b>	\$0.78	\$0.81	\$0.93
<b>EBAT 2430</b>	\$1.00	\$1.04	\$1.19
<b>EBAT 2450</b>	\$1.19	\$1.24	\$1.42



**Energizer. ZERO MERCURY®**



**RENATA® WATCH BATTERY KIT**

A. **RBAT: BASIC** This assortment includes 175 Renata Swiss-quality, 0% mercury, silver-oxide batteries, made up of the 16 most popular types, covering 85% of sales, as well as Renata's new low-profile battery display and precision-cut watch battery size selector.

B. **RBAT: DELUXE: T** This deluxe assortment contains everything needed to get started: the perfect mix of 225 assorted popular batteries, including 46 types covering 99% of sales, Renata's designer 60-drawer organizer display cabinet, two watch case openers, small Phillips and flat head screwdrivers, battery size selector, plastic tweezers, cross reference guides, inventory control form, watch battery tester, case vice table clamp, scratch brush contact case cleaner, spring bar tool and assorted spring bars, rubber gasket assortment, Renata official traffic poster and Renata Watch Battery Basics instructional DVD.

Item	Order #	Description	1+
A	<b>RBAT: BASIC</b>	Renata Basic Watch Battery Starter Kit	\$159.95
B	<b>RBAT: DELUXE: T</b>	Renata Deluxe Watch Battery Starter Kit	\$224.95



**GEMORO® ECONOTESTER**

This value-priced, well-designed tester is for testing watch, calculator, zinc air and photo batteries. Also includes wire test leads.

Order #	Description	1+
<b>59-1002</b>	GemOro EconoTester	\$12.00



**RENATA® WATCH AND BATTERY ANALYZER**

The Renata watch and battery tester is based upon the latest technology and is powered by a consumer replaceable Renata CR2430 lithium battery. This compact tester also features an automatic shut-off function after two minutes. The BWT94 has two battery testing positions, silver 1.55V and lithium 3.0V. The silver position is valid for testing both low and high-drain silver-oxide batteries, multi-drain watch batteries, and alkaline button cells. The lithium position is valid for both CR and BR lithium three-volt battery systems. The BWT94 watch test feature allows you to find out, with reasonable certainty and before actually opening an analog quartz watch, if the watch requires a battery change or watch repair.

Order #	Description	1+
<b>59-1001</b>	Renata Watch and Battery Analyzer	\$45.00



**RENATA® BATTERIES**

RENATA's comprehensive assortment of more than 40 different watch battery types, mostly of the silver oxide 1.55 V system, offers a suitable power source for any electronic device requiring an ultra-compact, long lasting, low voltage power source. Thanks to its close association with the Swiss watch industry, RENATA has first-hand knowledge of what a high-quality watch battery must stand for, an optimized volume/capacity ratio, dimensional precision and stability, high capacity retention on storage (low self-discharge), excellent reliability thanks to a uniformly high-quality level, state of the art leakproofness thanks to a sophisticated sealing process and constant availability.



- Each single blister can be torn away from the compact strip of 10 cells.
- Renata's type number, corresponding Japanese number and best before/use by date are printed on each individual blister.
- Black arrow indicates easy-opening tab located in one corner of the blister.



Order #	100+	25+	1+
EBAT 301	\$14.97	\$15.50	\$17.82
EBAT 303	\$14.97	\$15.50	\$17.82
EBAT 309	\$12.57	\$13.02	\$14.96
EBAT 315	\$9.98	\$10.34	\$11.88
EBAT 317	\$10.81	\$11.20	\$12.87
EBAT 319	\$7.58	\$7.85	\$9.02
EBAT 321	\$7.02	\$7.27	\$8.36
EBAT 329	\$11.00	\$11.39	\$13.09
EBAT 335	\$14.04	\$14.55	\$16.72
EBAT 337	\$22.08	\$22.87	\$26.29
EBAT 339	\$13.46	\$13.94	\$16.02
EBAT 341	\$16.26	\$16.84	\$19.36
EBAT 344	\$18.57	\$19.24	\$22.11
EBAT 346	\$16.82	\$17.42	\$20.02
EBAT 350	\$18.57	\$19.24	\$22.11
EBAT 357	\$14.97	\$15.50	\$17.82
EBAT 361	\$6.19	\$6.41	\$7.37
EBAT 362	\$6.19	\$6.41	\$7.37
EBAT 364	\$3.86	\$4.00	\$4.60

Order #	100+	25+	1+
EBAT 365	\$14.04	\$14.55	\$16.72
EBAT 366	\$14.04	\$14.55	\$16.72
EBAT 370	\$6.55	\$6.79	\$7.80
EBAT 371	\$6.55	\$6.79	\$7.80
EBAT 373	\$9.33	\$9.67	\$11.11
EBAT 376	\$4.20	\$4.35	\$5.00
EBAT 377	\$4.20	\$4.35	\$5.00
EBAT 379	\$6.65	\$6.89	\$7.92
EBAT 380	\$10.35	\$10.72	\$12.32
EBAT 381	\$8.69	\$9.00	\$10.35
EBAT 384	\$6.89	\$7.13	\$8.20
EBAT 386	\$14.97	\$15.50	\$17.82
EBAT 387S	\$16.63	\$17.23	\$19.80
EBAT 389	\$8.50	\$8.80	\$10.12
EBAT 390	\$8.50	\$8.80	\$10.12
EBAT 391	\$8.86	\$9.18	\$10.55
EBAT 392	\$6.89	\$7.13	\$8.20
EBAT 393	\$12.57	\$13.02	\$14.96
EBAT 394	\$10.35	\$10.72	\$12.32

Order #	100+	25+	1+
EBAT 395	\$7.58	\$7.85	\$9.02
EBAT 396	\$7.58	\$7.85	\$9.02
EBAT 397	\$7.58	\$7.85	\$9.02
EBAT 399	\$7.58	\$7.85	\$9.02
EBAT 1025	\$10.90	\$11.29	\$12.98
EBAT 1216	\$12.29	\$12.73	\$14.63
EBAT 1220	\$11.55	\$11.96	\$13.75
EBAT 1225	\$8.41	\$8.71	\$10.01
EBAT 1616	\$8.59	\$8.90	\$10.23
EBAT 1620	\$9.42	\$9.76	\$11.22
EBAT 1632	\$10.90	\$11.29	\$12.98
EBAT 2016	\$8.50	\$8.80	\$10.12
EBAT 2025	\$8.50	\$8.80	\$10.12
EBAT 2032	\$8.59	\$8.90	\$10.23
EBAT 2320	\$9.84	\$10.19	\$11.70
EBAT 2325	\$10.76	\$11.14	\$12.81
EBAT 2430	\$11.00	\$11.39	\$13.09
EBAT 2450N	\$13.12	\$13.59	\$15.62



**RENATA® BATTERY SIZE CHECKER**

This handy hard plastic tool is the world's easiest device for cross-referencing button and coin cell watch batteries. Start with the small holes and work your way around until you find a hole that fits. Type numbers marked next to the holes correspond to the cell size. The device indicates which option to use to power simple analogs or high drain applications incorporating back lights and alarms.

Order #	Description	1+
<b>RBAT101</b>	Renata Battery Size Checker	\$3.00





A B C

**EVEREADY® ALKALINE BATTERIES (BLISTER-PACKED)**

The EVEREADY® brand name has been part of powering people's lives for more than 160 years. These batteries are long lasting in low to moderate-drain devices. Estimated shelf life 5 years.

Item	Order #	Battery Size	Per Pack	12+	6+	1+
A	EBATAA	AA	Pack of 4	\$3.40	\$3.55	\$3.70
B	EBATAAA	AAA	Pack of 4	\$3.40	\$3.55	\$3.70
C	EBATC	C	Pack of 2	\$3.50	\$3.65	\$3.80
	EBATD	D	Pack of 2	\$3.59	\$3.74	\$3.90
	EBAT9V	9V	Pack of 1	\$3.31	\$3.46	\$3.60



D



E

**ENERGIZER® ADVANCED LITHIUM**

Lithium battery technology maximizes your gear's performance and keeps you going non-stop.

- Last up to 4X longer in digital cameras (versus ENERGIZER® Max)
- Last 20 hours longer in wireless gaming accessories.
- Last up to 30% longer in personal audio devices (versus ENERGIZER® Max)
- Weighs 1/3 less than standard alkaline.
- Available in AA, AAA, 9V • Estimated shelf life 10 years
- Leak resistant construction

Item	Order #	Battery Size	Per Pack	12+	6+	1+
D	EBATAA	AA	Pack of 4	\$8.83	\$9.22	\$9.60
E	EBATAAA	AAA	Pack of 4	\$8.83	\$9.22	\$9.60

**ENERGIZER® ULTIMATE LITHIUM BATTERIES**

For the countless electronic gadgets that you can't live without. Get the best lithium battery technology that's proven to be the world's longest lasting AA and AAA batteries in high-tech devices.

Other things you should know:

- Last up to 8x longer in digital cameras (versus ENERGIZER® Max AA only, results vary by camera)
- Weigh 1/3 less than standard alkaline batteries
- Performs in extreme temperatures from -40° to 140°
- Leak resistant construction
- 15-year storage life



F



G



H

Item	Order #	Battery Size	Per Pack	12+	6+	1+
F	EBATAA	AA	Pack of 8	\$16.51	\$17.23	\$17.95
G	EBATAA	AA	Pack of 2	\$9.15	\$9.55	\$9.95
H	EBATAAA	AAA	Pack of 4	\$9.15	\$9.55	\$9.95



J



K



L

**ENERGIZER® MAX (BLISTER-PACKED)**

- Long lasting dependable power for your everyday devices
- Available in AA AAA AAAA C D 9 volt
- Estimated shelf life 7 years

Item	Order #	Battery Size	Per Pack	12+	6+	1+
J	EBATAA	AA	Pack of 4	\$4.60	\$4.80	\$5.00
K	EBATAAA	AAA	Pack of 4	\$5.15	\$5.38	\$5.60
	EBATAAAA	AAAA	Pack of 2	\$3.31	\$3.46	\$3.60
L	EBATC	C	Pack of 2	\$4.83	\$5.04	\$5.25
	EBATD	D	Pack of 2	\$4.83	\$5.04	\$5.25
	EBAT9V	9V	Pack of 1	\$4.83	\$5.04	\$5.25

**ENERGIZER® E<sup>2</sup> RECHARGEABLE**

Features and Benefits

- Packed with four AA 2500 MAH cells
- ENERGIZER®'s highest capacity cells
- Charges both AA and AAA NiMH cells in 8½ hours
- Compact charger ideal for camera and travel bags
- Package fits on standard pegs



A B C

Item	Order #	Battery Size	Per Pack	12+	6+	1+
A	EBATAA	AA	Pack of 2	\$5.84	\$6.10	\$6.35
B	EBATAAA	AAA	Pack of 2	\$6.99	\$7.30	\$7.60
C	EBATC	C	Pack of 2	\$9.20	\$9.60	\$10.00
	EBATD	D	Pack of 2	\$9.20	\$9.60	\$10.00
	EBAT9V	9V	Pack of 1	\$9.20	\$9.60	\$10.00

**ENERGIZER® HEARING AID BATTERIES**

- World's only hearing aid battery dispenser
- Battery goes straight from dispenser to hearing aid
- Dispenser protects batteries from dust and dirt
- Available in sizes 10, 13, 312, 675, 1.4V

Order #	Description	Battery Size	Per Pack	12+	6+	1+
EBATHA	Renata Hearing Aid	#10	Pack of 6	\$2.48	\$2.59	\$2.70
EBATHA	Ez Turn & Lock	#10	Pack of 8	\$9.15	\$9.55	\$9.95
EBATHA	Ez Turn & Lock	#10	Pack of 16	\$14.67	\$15.31	\$15.95
EBATHA	Ez Turn & Lock	#13	Pack of 16	\$14.67	\$15.31	\$15.95
EBATHA	Ez Turn & Lock	#13	Pack of 8	\$9.15	\$9.55	\$9.95
EBATHA	Renata Hearing Aid	#13	Pack of 6	\$2.48	\$2.59	\$2.70
EBATHA	Ez Turn & Lock	#312	Pack of 8	\$14.67	\$15.31	\$15.95
EBATHA	Renata Hearing Aid	#312	Pack of 6	\$2.48	\$2.59	\$2.70
EBATHA	Ez Turn & Lock	#312	Pack of 16	\$9.15	\$9.55	\$9.95
EBATHA	Renata Hearing Aid	#675	Pack of 6	\$2.99	\$3.12	\$3.25
EBATHA	Ez Turn & Lock	#675	Pack of 8	\$9.15	\$9.55	\$9.95



**ENERGIZER® SPECIAL APPLICATION BATTERIES**

- These lithium batteries have high-energy density and a long-life power source
- Used in photography devices, calculators, memory backup, pocket pages, and watches

Order #	Description	Volts	Per Pack	12+	6+	1+
EBAT1.5V	N	1.5V	Pack of 2	\$2.53	\$2.64	\$2.75
EBAT12V	A23	12V	Pack of 2	\$2.67	\$2.78	\$2.90







**ENERGIZER® CHARGERS**

**A. Smart Battery Charger**

Countdown timer shows how long until batteries are charged. Battery fuel gauge shows charge status. Bad battery alert detects, alerts, and shuts off charging when a non-NiMH or old NiMH battery is inserted. Large visual display can be viewed from across the room. Charges two or four AA or AAA NiMH rechargeable batteries.

**B. 15-Minute Battery Charger**

Charges 1-4 AA or AAA NiMH rechargeable batteries. Charge in your car with the included car adapter or at home with the wall adapter. Easy-to-read charge status indicator light. Energy Star certified.

**C. Family Charger**

- Super safe-will only begin charging when closed
- Easy-to-read charge status indicator
- Charges up to eight AA, eight AAA, four C, four D, or two 9V rechargeable batteries

Item	Order #	Description	12+	6+	1+
A	<b>EBATCHARGER</b>	Smart Charger	\$19.27	\$20.11	\$20.95
B	<b>EBATCHARGER</b>	15-Minute Charger	\$38.00	\$39.65	\$41.30
C	<b>EBATCHARGER</b>	Family Charger	\$30.31	\$31.63	\$32.95



**DELUXE EVEREADY® BATTERY TOOL KIT**

Contains the tools you need to change a battery in a convenient, faux-leather pouch. Has a zipper and elastic bands to keep tools securely in place. Shipped with a complete list of tools for easy replacement.

Order #	Description	12+	6+	1+
<b>59-2500</b>	Battery Tool Kit	\$26.48	\$28.04	\$31.15



**WATCH TOOL KIT**

This watch kit is specifically designed for watch battery replacement of all brand name watches. The tools included will allow you to open the watch back, remove the old watch battery, safely handle all components, replace your watch batteries, size or replace your watchband, replace or adjust watchband clasp, or remove watchband links.

- Yellow case opener
- Aluminum spring bar tool
- Watchmakers hammer
- Blue band opener
- Bracelet holding block
- Pocket case opener
- 1.6mm screwdriver
- Case holder
- 2.0mm screwdriver Multifunction watchband remover
- Plastic tweezers

Order #	Description	12+	6+	1+
<b>59-2600</b>	Watch Tool Kit	\$34.68	\$36.72	\$40.80



**ENERGIZER® ELECTRIC WATCH BATTERY TESTER**

Tests full range of silver, mercury, and coin lithium watch/electronic batteries. Compact, modern design is easy to use. Instructions on bottom of tester.

Order #	Description	12+	6+	1+
<b>59-1000</b>	Energizer® Electric Watch Battery Tester	\$16.51	\$17.23	\$17.95

**ENERGIZER® WATCH BATTERY ANALYZER**

Electronic testing device. Determines if there is a problem with the watch or if the battery needs replacing without having to open the watch case. Easy-to-read instruction manual included. Tests all types of batteries: silver-oxide, high-drain, silver-dioxide, low drain, mercury, and lithium.

Order #	Description	12+	6+	1+
<b>59-3000</b>	Energizer® Watch Battery Analyzer	\$45.01	\$47.66	\$52.95



**QT 2500 BATTERY AND PULSE TESTER**

Test the pulse of quartz watch movement. Can be checked with movement out of watch case or inside of watch case. Two options to check silver-oxide low and high-drain battery power. Additionally, this tester allows you to check the coil of the watch movement with the power conductor indicators. Very practical tool for battery and quartz movement changers.

Order #	Description	12+	6+	1+
<b>59-3002</b>	Tester	\$15.26	\$16.16	\$17.95



**ANTI-STATIC BENCH MAT**

Flexible mat is used for organizing tools and projects.

Order #	Description	WxL	12+	6+	1+
<b>59-0488</b>	Light Green	14"x9½"	\$11.50	\$12.00	\$12.50



**BATTERY CHANGING PARTS KIT**

Kit contains spare parts for changing watch batteries. Contains battery clamp screws, electronic module screws, battery clamps, insulators, and watch gaskets.

Order #	Description	12+	6+	1+
<b>59-0280</b>	200-piece Kit	\$32.02	\$33.41	\$34.80



# BEADING AND STRINGING SUPPLIES

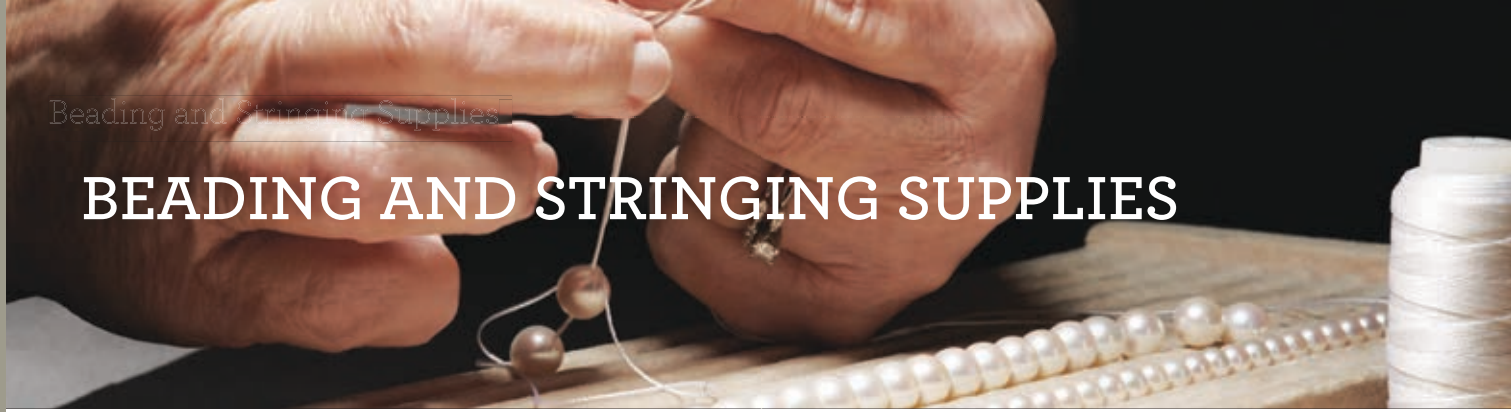

## 100% PURE SILK BEAD STRINGING CORD

Silk is the finest natural fiber in the world. This smooth, twisted, three-ply, 100% pure silk thread has the most luxurious feel and softest sheen of any natural fiber. Durable enough to withstand the abrasion of pearls, glass beads, and gemstones, our bead cord is extremely supple yet resistant to stretch and wear.

Order # 38-60300



Thread	Diameter	Length	Tested Strength	12+	6+	1+
<b>WHITE CORD</b>						
A	0.012" (0.305mm)	21 ft	5.9 lb	\$9.27	\$9.81	\$10.90
	0.013" (0.325mm)	16 ft	8.2 lb	\$8.76	\$9.27	\$10.30
	0.014" (0.348mm)	11 ft	10.9 lb	\$8.76	\$9.27	\$10.30
	0.017" (0.381mm)	9½ ft	12.8 lb	\$8.76	\$9.27	\$10.30
<b>BLACK CORD</b>						
B	0.012" (0.305mm)	65 ft	5.9 lb	\$9.03	\$10.32	\$12.90
	0.013" (0.325mm)	50 ft	8.2 lb	\$9.03	\$10.32	\$12.90
	0.008" (0.203mm)	97½ ft	3.7 lb	\$9.03	\$10.32	\$12.90
	0.017" (0.381mm)	7 ft	12.8 lb	\$9.03	\$10.32	\$12.90
	0.014" (0.348mm)	35 ft	10.9 lb	\$9.03	\$10.32	\$12.90

## POLYESTER CORD SPOOLS

Popular polyester thread for stringing pearls. Made in Japan. Sold by the spool.

Order # 38-60355



Item	Thread Size	Diameter	Length	12+	6+	1+
C	20	0.46mm	1000 ft	\$14.37	\$15.21	\$16.90
D	30	0.44mm	2000 ft	\$11.48	\$12.15	\$13.50
E	40	0.39mm	2000 ft	\$9.86	\$10.44	\$11.60

## BEADALON® POLY SPARKLE THREAD

Add some sparkle to your stringing projects. Can be used with other stringing materials or by itself. Use the collapsible eye needle with this material.

Order # 38-71950

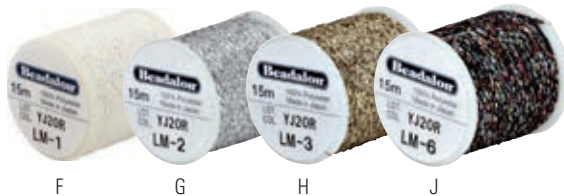

Item	Color	Diameter	Length	12+	6+	1+
F	White	0.027" (0.7mm)	49 ft	\$3.19	\$3.64	\$4.55
G	Silver	0.027" (0.7mm)	49 ft	\$3.19	\$3.64	\$4.55
H	Gold	0.027" (0.7mm)	49 ft	\$3.19	\$3.64	\$4.55
J	Black	0.027" (0.7mm)	49 ft	\$3.19	\$3.64	\$4.55

## 100% SILK CARDED BEAD CORD

The beaders prefer the tight-woven silk cord needle attached. When stringing, remove all the cord from the card and string your strand at the end without the twisted stainless steel needle. When you are finished, cut the bead strand off and use the remaining silk (with the needle still attached) for another project. Sold by the card.



Order # 38-50000



White	Dark Pink	Light Pink	Red	Beige	Yellow	Dark Blue	12+	6+	1+
Size 1	—	—	—	—	—	—	\$1.87	\$1.98	\$1.70
Size 2	Size 2	Size 2	Size 2	Size 2	Size 2	Size 2	\$1.45	\$1.53	\$1.70
Size 3	Size 3	Size 3	Size 3	Size 3	Size 3	Size 3	\$1.45	\$1.53	\$1.70
Size 4	Size 4	Size 4	Size 4	Size 4	Size 4	Size 4	\$1.45	\$1.53	\$1.70
Size 5	Size 5	Size 5	Size 5	Size 5	Size 5	Size 5	\$1.45	\$1.53	\$1.70
Size 6	Size 6	Size 6	Size 6	Size 6	Size 6	Size 6	\$1.45	\$1.53	\$1.70
Size 8	Size 8	Size 8	Size 8	Size 8	Size 8	Size 8	\$1.45	\$1.53	\$2.20



Lilac	Amethyst	Green	Brown	Turquoise	Gray	Black	12+	6+	1+
Size 2	Size 2	Size 2	Size 2	Size 2	Size 2	Size 2	\$1.45	\$1.53	\$1.70
Size 3	Size 3	Size 3	Size 3	Size 3	Size 3	Size 3	\$1.45	\$1.53	\$1.70
Size 4	Size 4	Size 4	Size 4	Size 4	Size 4	Size 4	\$1.45	\$1.53	\$1.70
Size 5	Size 5	Size 5	Size 5	Size 5	Size 5	Size 5	\$1.45	\$1.53	\$1.70
Size 6	Size 6	Size 6	Size 6	Size 6	Size 6	Size 6	\$1.45	\$1.53	\$1.70
Size 8	Size 8	Size 8	Size 8	Size 8	Size 8	Size 8	\$1.87	\$1.98	\$2.20

## NYLON (POLYAMID) CARDED BEAD CORD

Poly nylon, also referred to as Polyamid, is a strong, fray-resistant, and very knottable stringing material. The nylon card has needle attached. This nylon creates very tight knots and has the stretch of regular nylon. Sold by the card.

Order # 38-40000



White	Dark Pink	Light Pink	Red	Beige	Yellow	Dark Blue	12+	6+	1+
Size 1	—	—	—	—	—	—	\$1.28	\$1.35	\$1.50
Size 2	Size 2	Size 2	Size 2	Size 2	Size 2	Size 2	\$1.28	\$1.35	\$1.50
Size 3	Size 3	Size 3	Size 3	Size 3	Size 3	Size 3	\$1.28	\$1.35	\$1.50
Size 4	Size 4	Size 4	Size 4	Size 4	Size 4	Size 4	\$1.28	\$1.35	\$1.50
Size 5	Size 5	Size 5	Size 5	Size 5	Size 5	Size 5	\$1.28	\$1.35	\$1.50
Size 6	Size 6	Size 6	Size 6	Size 6	Size 6	Size 6	\$1.28	\$1.35	\$1.50
Size 8	Size 8	Size 8	Size 8	Size 8	—	Size 8	\$1.32	\$1.40	\$1.55



Lilac	Amethyst	Green	Brown	Turquoise	Gray	Black	12+	6+	1+
Size 2	Size 2	Size 2	Size 2	Size 2	Size 2	Size 2	\$1.70	\$1.80	\$2.00
Size 3	Size 3	Size 3	Size 3	Size 3	Size 3	Size 3	\$1.70	\$1.80	\$2.00
Size 4	Size 4	Size 4	Size 4	Size 4	Size 4	Size 4	\$1.70	\$1.80	\$2.00
—	Size 5	Size 5	Size 5	Size 5	Size 5	Size 5	\$1.70	\$1.80	\$2.00
Size 6	Size 6	Size 6	Size 6	Size 6	Size 6	Size 6	\$1.70	\$1.80	\$2.00
Size 8	Size 8	Size 8	Size 8	Size 8	Size 8	Size 8	\$1.70	\$1.80	\$2.00





**BEADALON® ULTRA SUPPLEMAX**

Ultra abrasion-resistant supplemax is a technological advance from Beadalon. This material has 15 times the abrasion resistance of other nylon bead stringing materials. It has a soft white appearance, which makes it look thread-like while maintaining excellent drape.

Item	Order #	Color	Diameter	Length	12+	6+	1+
A	38-7120	Clear	0.01" (0.25mm)	164 ft	\$1.28	\$1.35	\$1.50
B	38-7188	White	0.01" (0.25mm)	82 ft	\$2.13	\$2.25	\$2.50
C	38-7189	White	0.012" (0.3mm)	82 ft	\$2.13	\$2.25	\$2.50



**ELASTICITY**

Make popular stretch jewelry in a snap. Just string beads or charms onto Elasticity and finish with a secure knot. Apply rubber cement to the knot to protect it and provide a professional appearance. Sold in 25-meter spools.

Order # 38-71300

Item	Color	Diameter	Length	12+	6+	1+
D	Clear	0.02" (0.5mm)	82 ft	\$7.18	\$7.61	\$8.45
	Clear	0.039" (1mm)	82 ft	\$8.20	\$8.69	\$9.65
E	Black	0.02" (0.5mm)	82 ft	\$7.18	\$7.61	\$8.45
	Black	0.039" (1mm)	82 ft	\$8.20	\$8.69	\$9.65



**BEADALON® WILDFIRE® THREAD**

Wildfire beading thread features the strength and durability of DandyLine with a smooth, thermally-bonded coating. This creates a superior stringing product that cannot be pierced with a needle. Super strong, waterproof, and near zero-stretch, this cord will not fray at the ends, making it easy to thread through a needle. This colorfast, knotable, supple cord is also available for multiple-strand seeded bead designs.

Order # 38-71910

Item	Color	Diameter	Length	12+	6+	1+
F	Black	0.006" (0.15mm)	50 ft	\$6.69	\$7.64	\$9.55
	Black	0.008" (0.02mm)	50 ft	\$6.69	\$7.64	\$9.55
G	White	0.006" (0.15mm)	50 ft	\$6.69	\$7.64	\$9.55
	White	0.008" (0.02mm)	50 ft	\$6.69	\$7.64	\$9.55

**DIAMETERS AND USES**

Actual Size	Size	Diameter	49 Strand	19 Strand	Recommended Uses
—	XXS	0.25 (0.010")		•	Seed beads, freshwater pearls, and smaller gemstones. For lightweight stringing and bead weaving.
—	XS	0.30 (0.012")		•	Crystal beads, seed beads, and freshwater pearls. Popular with beads with small holes.
—	XS	0.33 (0.013")	•		
—	S	0.38 (0.015")	•	•	Medium to heavy gemstones, crystals, seed beads, and glass and metal beads. Most versatile sizes for making necklaces, bracelets, and anklets.
—	M	0.46 (0.018")	•	•	
—	M1	0.51 (0.020")			Large or heavy gemstone beads with unevenly drilled bead holes. For stringing medium-weight designs.
—	L	0.53 (0.021")	•	•	
—	L1	0.61 (0.024")	•	•	Large or heavy beads with large drill holes such as African trade beads, glass, or gemstones.
—	XL	0.66 (0.026")			
—	XL	0.76 (0.030")	•		Ideal for stringing larger, heavier beads including large glass beads, medium to large crystals, chunky metal, and heavy stone beads.
—	XXL	0.91 (0.036")	•		

**KINK-FREE TITANIUM BEAD STRINGING WIRE**

The first nylon-coated, kink-free beading wire. This technologically advanced titanium alloy wire is super-elastic and offers dramatic kink resistance. When pinched and released, the wire returns to its original straight shape without kinking. Ideal for use on jewelry designs subject to lots of twisting, looping, and extreme movement, the wire holds its shape and works well on designs made with crystal, metal, and medium to heavier weight beads. Made in the USA.

Order # 38-7114

Diameter	Length	Model	Shank	Tested Strength	12+	6+	1+
0.015" (0.38mm)	10 ft	#2	#1	33 lb	\$30.77	\$35.16	\$43.95
0.018" (0.46mm)	10 ft	#2	#1	44 lb	\$30.77	\$35.16	\$43.95



**COLLAPSIBLE EYE NEEDLES**

Needles have a specially designed eye that automatically collapses and instantly reshapes when it is pulled through the bead, perfect for stringing beads with very small holes. Needles are five inches long and kink resistant.

Order # 38-01060

Description	Diameter	12+	6+	1+
Fine	0.012mm	\$2.68	\$2.84	\$3.15
Medium	0.014mm	\$2.68	\$2.84	\$3.15
Heavy	0.020mm	\$2.68	\$2.84	\$3.15



**TWISTED-BEAD NEEDLES**

Twisted-bead needles are ideal for general beading. They are approximately 3 1/2" long and flexible.

Order # 38-01000

Description	Diameter	12+	6+	1+
Fine	0.23mm	\$4.21	\$4.46	\$4.95
Medium	0.35mm	\$4.21	\$4.46	\$4.95
Heavy	0.49mm	\$4.21	\$4.46	\$4.95



**STAINLESS BEADING NEEDLES**

Easy threading is yours with this needle. The eye runs the entire length of the needle.

Order # 38-09070

Description	Diameter	12+	6+	1+
Small	0.30mm	\$6.58	\$6.86	\$7.15
Medium	0.39mm	\$6.58	\$6.86	\$7.15





Silver-Plated  
Gold-Plated

**19-STRAND WIRE (PLATED COLORS)**

Supple, 19-strand stainless steel wire is plated with silver or 24K gold then coated with clear, soft nylon. Combine the flexibility and strength of 19-strand wire with the luster of precious metals. Choose brilliant silver-plated wire to coordinate with sterling silver or silver-plated findings. Glimmering 24K gold-plated wire complements gold and plated metal jewelry components for finer quality jewelry designs. Made in the USA.

Order # 38-71040

Surface Coating	Diameter	Length	Tested Strength	12+	6+	1+
Silver-Plated	0.015" (0.38mm)	15 ft	17 lb	\$8.88	\$9.26	\$9.65
Silver-Plated	0.018" (0.46mm)	15 ft	26 lb	\$8.88	\$9.26	\$9.65
24K Gold-Plated	0.015" (0.38mm)	15 ft	17 lb	\$15.78	\$16.46	\$17.15
24K Gold-Plated	0.018" (0.46mm)	15 ft	26 lb	\$15.78	\$16.46	\$17.15



Gold-Plated  
Silver-Plated

**19-STRAND WIRE (PLATED COLORS)**

Create stunning designs with the luxurious sheen of precious metal. These 49-strand silver-plated wires combine the softness and flexibility of traditional 49-strand wire with the strength of steel. Clear nylon coating over silver or 24K gold-plated stainless steel wire. Made in the USA.

Order # 38-70060

Surface Coating	Diameter	Length	Tested Strength	12+	6+	1+
Silver-Plated	0.015" (0.38mm)	10 ft	20 lb	\$15.51	\$16.43	\$18.25
Silver-Plated	0.018" (0.46mm)	10 ft	26 lb	\$14.62	\$15.48	\$17.20
Gold-Plated	0.015" (0.38mm)	10 ft	20 lb	\$14.58	\$15.44	\$17.15
Gold-Plated	0.018" (0.46mm)	10 ft	26 lb	\$14.58	\$15.44	\$17.15



Bright  
Black  
Bronze

**49-STRAND WIRE (STANDARD COLORS)**

Combines the flexibility and softness of thread with the strength and durability of stainless steel wire. Designed for stringing all types of beads and pearls Beadalon® 49-strand is the softest and most popular beading wire. It drapes very naturally without kinking. It is the finest choice wire for creating professional jewelry that remains securely strung. The smooth nylon coating provides abrasion resistance prevents kinking and prolongs strand life. Made in the USA.

Order # 38-70900

Surface Coating	Diameter	Length	Tested Strength	Wire Gauge	12+	6+	1+
Bright	0.013" (0.33mm)	30 ft	13 lb	28	\$24.65	\$26.10	\$29.00
Bright	0.015" (0.38mm)	30 ft	20 lb	27	\$12.07	\$12.78	\$14.20
Bright	0.018" (0.46mm)	30 ft	26 lb	25	\$10.54	\$11.16	\$12.40
Bright	0.024" (0.61mm)	30 ft	40 lb	23	\$11.41	\$11.90	\$12.40
Black	0.015" (0.38mm)	30 ft	20 lb	27	\$14.92	\$15.80	\$17.55
Black	0.018" (0.46mm)	30 ft	26 lb	25	\$14.92	\$15.80	\$17.55
Bronze	0.015" (0.38mm)	30 ft	20 lb	27	\$13.73	\$14.54	\$16.15
Bronze	0.018" (0.46mm)	30 ft	26 lb	25	\$16.87	\$17.87	\$19.85

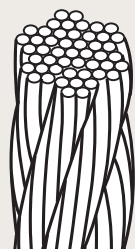

**49 STRAND**

- Softest, Most Supple
- Maximum Flexibility
- Maximum Drape
- Maximum Kink Resistance
- Maximum Abrasion Resistance
- Superior Strength



**19 STRAND**

- Excellent Flexibility
- Excellent Drape
- Excellent Kink Resistance
- Excellent Abrasion Resistance
- Superior Strength

**19-STRAND WIRE (STANDARD COLORS)**

Specifically developed for bead stringing, Beadalon® 19-strand wire is an ideal choice for creating jewelry designs or repairs. Only slightly less flexible than 49-strand wire and with less cost, this wire contains 19 strands of strong stainless steel. Nylon coated for increased kink and abrasion resistance, Beadalon® 19-strand wire is easy to work with, very strong, and perfect for jewelry that lasts. Made in the USA.

Order # 38-70850

Surface Coating	Diameter	Length	Tested Strength	Wire Gauge	12+	6+	1+
Bright	0.01" (0.25mm)	30 ft	17 lb	30	\$8.76	\$9.27	\$10.30
Bright	0.012" (.30mm)	30 ft	12 lb	28	\$9.18	\$9.72	\$10.80
Bright	0.015" (0.38mm)	30 ft	17 lb	27	\$8.67	\$9.18	\$10.20
Bright	0.018" (0.46mm)	30 ft	26 lb	25	\$9.48	\$10.04	\$11.15
Bronze	0.021" (.53mm)	30 ft	35 lb	24	\$10.50	\$11.12	\$12.35
Black	0.018" (0.46mm)	30 ft	26 lb	25	\$10.50	\$11.12	\$12.35
Bronze	0.015" (.38mm)	30 ft	17 lb	27	\$9.65	\$10.22	\$11.35
Bronze	0.018" (.46mm)	30 ft	26 lb	25	\$9.65	\$10.22	\$11.35
Black	0.015" (0.38mm)	30 ft	35 lb	27	\$10.12	\$10.71	\$11.90



Bright  
Black  
Bronze

**19-STRAND WIRE (SATIN COLORS)**

Satin Colors give designs a soft, warm glow of silver, gold, and copper. The special nylon coating on Satin Colors offers a soft, silky feel and a unique, matte coloring. The coating also creates a softer, more supple feel and drape. Great for designs requiring exposed wire. Made in the USA.

Order # 38-71210

Surface Coating	Diameter	Length	Tested Strength	12+	6+	1+
Satin Gold	0.015" (.38mm)	30 ft	12 lb	\$10.12	\$10.71	\$11.90
Satin Gold	0.018" (.46mm)	30 ft	17 lb	\$12.07	\$12.78	\$14.20
Satin Silver	0.015" (.38mm)	30 ft	12 lb	\$10.33	\$10.94	\$12.15
Satin Silver	0.018" (.46mm)	30 ft	17 lb	\$10.75	\$11.39	\$12.65



Gold  
Silver

**WIRE BENDING PLIERS**

The bend in these pliers reduces the time needed to create professional wire wrapping and stone setting. Each end of the T-shaped head fits a different gauge.

Order #	Gauge (for bending)	12+	6+	1+
46-4040	22, 24 gauge	\$18.70	\$19.80	\$22.00
46-4040	20, 21 gauge	\$18.70	\$19.80	\$22.00



**WIRE TWISTER AND JUMP RING MAKER**

Together in one convenient set you can twist wire and make custom jump rings in the sizes and wire gauges you want. The Jump Ring Maker comes in different configurations so you can make just the size you need. Use the wire twister to make pre-twisted color combinations. Then make twisted jump rings for all your jewelry or craft projects. Easy to use, fast, and fun.

Order #	Description	12+	6+	1+
38-0189	Wire Twisting/Jump Ring Making Combo Set	\$52.45	\$55.53	\$61.70



**BEADALON® STANDARD SPIRAL MAKER**

Creates perfect spirals out of any metal wire up to 20 gauge. Use small pieces of the diameter wire you intend to make the spiral as a washer on the three screws. Tighten nut and insert the same gauge wire into the device. Center the wire in the center hole and insert the twister handle so the wire is inside the slit on the handle. Twist the handle until the desired size of coil is reached (maximum of 16mm).

Order #	Description	Diameter	12+	6+	1+
38-9024	Standard	5/8" (16mm)	\$14.54	\$15.39	\$17.10
38-9025	Large	1 1/4" (32mm)	\$15.94	\$16.88	\$18.75







**GERMAN-STYLE PLATED WIRE**

Excellent quality shaping wire available in several gauges and shapes. This copper and brass wire has a tarnish-resistant coating and has the perfect temper and finish for most jewelry wire wrapping uses. Fancy round wire is constructed of two strands of round wire that have been twisted together and run through tooling to make the outside round again (instead of the usual swirl/bumps of twisted wire) creating a very unique pattern.

Order #	Color	Gauge	Diameter	Length	12+	6+	1+
<b>ROUND</b>							
38-7096	Brass-Plated	20	0.032" (0.81mm)	19 <sup>7</sup> / <sub>16</sub> ft	\$3.01	\$3.44	\$4.30
38-7096	Silver-Plated	24	0.020" (0.51mm)	39 <sup>3</sup> / <sub>4</sub> ft	\$3.01	\$3.44	\$4.30
38-7097	Brass-Plated	20	0.032" (0.81mm)	19 <sup>7</sup> / <sub>16</sub> ft	\$3.01	\$3.44	\$4.30
38-7097	Brass-Plated	24	0.020" (0.51mm)	39 <sup>3</sup> / <sub>4</sub> ft	\$3.01	\$3.44	\$4.30
<b>SQUARE</b>							
38-7098	Silver-Plated	20	0.032" (0.81mm)	6 <sup>1</sup> / <sub>2</sub> ft	\$5.29	\$6.04	\$7.55
38-7099	Brass-Plated	20	0.032" (0.81mm)	6 <sup>1</sup> / <sub>2</sub> ft	\$5.29	\$6.04	\$7.55
<b>HALF-ROUND</b>							
38-7109	Brass-Plated	20	0.032" (0.81mm)	9 <sup>3</sup> / <sub>4</sub> ft	\$6.42	\$6.80	\$7.55

Also available in Fancy gauge 20-24. Items 38-7110 and 38-7111.



**ARTISTIC WIRE**

These wires are made by first plating the copper wire with a precision layer of pure silver. Then, we carefully apply our unique enamel color and tarnish-resistant coating on top of this silver plating. The silver plating beneath the color adds an incredible high shine and brilliance to the wire.

Item	Surface Coating	Gauge	Length	12+	6+	1+
<b>Order # 38-00120</b>						
	Brass-Plated	22	8 yds	\$2.31	\$2.64	\$3.30
A	Brass-Plated	20	6 yds	\$2.31	\$2.64	\$3.30
	Silver-Plated	22	8 yds	\$4.20	\$4.80	\$6.00
B	Silver-Plated	20	6 yds	\$4.20	\$4.80	\$6.00



**ARTISTIC WIRE KITS (12 COLORS)**

Buy the Dozen packs feature 12 different colors all in one gauge. Provide your customers with the best vari-pack on the market.

Item	Surface Coating	Gauge	Length	12+	6+	1+
<b>Order # 38-00120</b>						
C	Multi	20	3 yds	\$9.42	\$10.76	\$13.45
	Multi	24	5 yds	\$9.42	\$10.76	\$13.45
D	Multi	22	5 yds	\$9.42	\$10.76	\$13.45
	Multi	20	5 yds	\$21.77	\$24.88	\$31.10



**ARTISTIC WIRE (THREE COLORS)**

Buy-the-Three packs feature three different colors all in one gauge. These colors were specially selected to work well together for any project.

Item	Surface Coating	Gauge	Length	12+	6+	1+
<b>Order # 38-00120</b>						
E	Black, Natural, Gun	20	3 yds	\$3.44	\$3.87	\$4.30
	Black, Natural, Gun	22	5 yds	\$3.44	\$3.87	\$4.30
F	Silver, Brass, Hematite	20	3 yds	\$3.44	\$3.87	\$4.30
	Silver, Brass, Hematite	22	5 yds	\$3.44	\$3.87	\$4.30



**FRENCH WIRE**

Use this coiled fine-gauge wire on knotted strands to keep clasps from wearing or cutting through unprotected silk or bead cord. It creates a professional appearance and is commonly used as the preferred method for stringing pearls.

**Order # 38-60500**

Surface Coating	Diameter	Length	12+	6+	1+
Gold-Plated	0.024" (0.8mm)	1m	\$7.08	\$7.39	\$7.70
Gold-Plated	0.027" (0.9mm)	1m	\$6.55	\$6.93	\$7.70
Gold-Plated	0.031" (1mm)	1m	\$8.42	\$8.78	\$9.15
Silver-Plated	0.035" (1.1mm)	1m	\$7.08	\$7.39	\$7.70
Silver-Plated	0.024" (0.8mm)	1m	\$7.08	\$7.39	\$7.70
Silver-Plated	0.027" (0.9mm)	1m	\$8.42	\$8.78	\$9.15
Silver-Plated	0.031" (1mm)	1m	\$7.08	\$7.39	\$7.70

**Kit Order # 38-60500**

Silver-Plated	French Wire Assortment	4m	\$15.69	\$16.37	\$17.05
Gold-Plated	0.035" (1.1mm)	1m	\$15.69	\$16.37	\$17.05

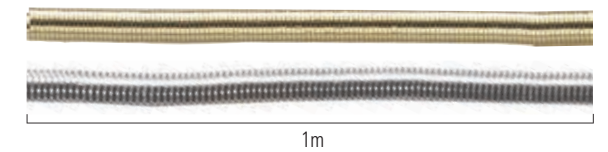

1m

**49-STRAND JEWELRY CABLE**

Works well for metal beading and for interesting jewelry designs. Try separating the strands to create interesting individual wavy cables. Then, add beads and finish with a crimp and clasp for stylish and unique creations.

Item	Order #	Material	Diameter	Length	12+	6+	1+
A	38-8010	Stainless Steel	0.036" (0.92mm)	30'	\$10.29	\$10.89	\$12.10
B	38-8012	Stainless Steel	0.045" (1.14mm)	30'	\$10.41	\$11.03	\$12.25



A

B

**SHAPED MEMORY WIRE**

String on beads for a flexible design that retains its round shape. Do not use cutters to cut. Bend back and forth to break metal. Then, use pliers to coil the end around or use end caps available. Wire diameter is .025" (.62mm).

Item	Order #	Description	Per Pack	12+	6+	1+
C	38-7140	Ring	195 coils	\$7.69	\$8.15	\$9.05
D	38-7141	Small Bracelet	75 coils	\$7.69	\$8.15	\$9.05
	38-7142	Large Bracelet	60 coils	\$7.69	\$8.15	\$9.05
	38-7143	Small Necklace	36 coils	\$7.69	\$8.15	\$9.05
	38-7144	Large Necklace	32 coils	\$7.69	\$8.15	\$9.05

**MEMORY WIRE END CAPS VARIETY PACK**

Finish off Remembrance Memory Wire designs with end caps for a professional look. End caps are open on one side to accommodate Remembrance and plated steel memory wire. End caps are a fun way to dangle charms. Secure the end cap and last few beads with BeadFix<sub>z</sub> adhesive for a fast and easy finish.

Item	Order #	Surface Coating	Thickness	Per Pack	12+	6+	1+
E	38-7154	Silver-Plated	3-4mm	72	\$7.18	\$8.20	\$10.25



D



E



**EASY EAR WIRE**

Easy to use, fully automatic, and hand-operated. Just put in a straight piece of wire and in seconds you have an elegant ear wire ready for use. So easy and quick you will not need to keep an inventory of ear wires for your earrings. Simply make them as you need them.

Order #	Description	12+	6+	1+
38-9023	Ear Wire Maker	\$22.06	\$23.36	\$25.95

**MAGNETIC SKRIMP™ KIT**

Scrimp Findings are an innovative screw finding that takes the place of a crimp, and are reusable. A tiny set screw inside holds Beadalon® wires in place. The complete Scrimp Kit contains its own screwdriver and an ample supply of Scrimp Findings with screws. Additional screws are cleverly held within the handle of the screwdriver. A secure-and flexible finish. See tip diagram below.



**Order # 38-71550**

Item	Description	Surface Coating	12+	6+	1+
A	10-Piece Bullet SKRIMP™ Kit	Gold-Plated	\$7.72	\$8.37	\$9.30
	10-Piece Oval SKRIMP™ Kit	Silver-Plated	\$9.01	\$9.77	\$10.85
	10-Piece Bullet SKRIMP™ Kit	Silver-Plated	\$7.72	\$8.37	\$9.30

**INDIVIDUAL SKRIMP™ FINDINGS**

Scrimp findings are the unique marriage of a screw finding within a crimp, a fresh alternative.

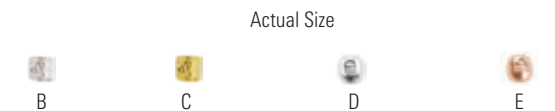

Actual Size



Enlarged View

Item	Order #	Description	Surface Coating	12+	6+	1+
B	38-7163	SCRIMP™ Findings	Silver-Plated	\$5.44	\$5.90	\$6.55
C	38-7162	SCRIMP™ Findings	Gold-Plated	\$5.44	\$5.90	\$6.55
D	38-7165	SCRIMP™ Findings	Silver-Plated	\$6.43	\$6.98	\$7.75
E	38-7167	SCRIMP™ Findings	Copper-Plated	\$6.43	\$6.98	\$7.75

**SCRIMP FINDING INSTRUCTIONS**

1. Begin by loosening screw to allow wire to go through the Scrimp Finding.
2. Feed the wire through the Scrimp Finding, and Wire Guardian [optional], attach a clasp, and feed back through the Scrimp Finding.
3. Tighten screw for a secure and clean finish.

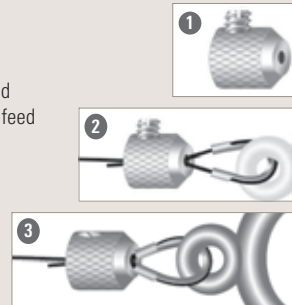

TIP: For an extra strong Scrimp Finding, add a small amount of BeadFix™ to the screw.

**BEAD TIPS**



Item	Order #	Quality	Hole ID	6+	3+	1+
F	262	Nickel-Plated	0.71mm	\$0.46	\$0.47	\$0.49
F	262	Yellow-Plated	0.71mm	\$0.53	\$0.54	\$0.56
G	263	Nickel-Plated	0.92mm	\$0.61	\$0.63	\$0.63
G	263	Yellow-Plated	0.92mm	\$0.57	\$0.59	\$0.59

Items sold each, unless noted otherwise.

**CRIMP BEADS AND CRIMP TUBES**

Now it's easier than ever to have the correct size Crimp Bead or Tube handy for repairs or beading. Each individual bottle is marked with the Crimp Bead and Crimp Tube size number that corresponds to the information on all Beadalon wire packages to make using and storing the proper sizes very easy.



Order #	Size	OD	ID	Type	Surface Coating	Per Pack	12+	6+	1+
BEADALON®									
38-7000	#1	2mm	1.3mm	Bead	Silver-Plated	430	\$4.46	\$4.73	\$5.25
38-7001	#1	2mm	1.3mm	Bead	Gold-Plated	430	\$4.46	\$4.73	\$5.25
38-7002	#1	2mm	1.3mm	Bead	Black-Plated	430	\$4.46	\$4.73	\$5.25
38-7003	#2	2.5mm	1.5mm	Bead	Silver-Plated	400	\$4.25	\$4.50	\$5.00
38-7005	#2	2.5mm	1.5mm	Bead	Black-Plated	400	\$4.25	\$4.50	\$5.00
38-7010	#1	1.3mm	0.8mm	Tube	Silver-Plated	470	\$4.85	\$5.13	\$5.70
38-7011	#1	1.3mm	0.8mm	Tube	Gold-Plated	370	\$4.85	\$5.13	\$5.70
38-7012	#2	1.8mm	1.3mm	Tube	Silver-Plated	365	\$3.87	\$4.10	\$4.55
38-7013	#2	1.8mm	1.3mm	Tube	Gold-Plated	365	\$3.87	\$4.10	\$4.55
38-7014	#3	2mm	1.5mm	Tube	Silver-Plated	384	\$4.08	\$4.32	\$4.80
38-7015	#3	2mm	1.5mm	Tube	Gold-Plated	384	\$4.08	\$4.32	\$4.80
38-7016	#4	2.5mm	2mm	Tube	Silver-Plated	234	\$4.55	\$4.75	\$4.95
38-7017	#4	2.5mm	2mm	Tube	Gold-Plated	234	\$4.55	\$4.75	\$4.95

**PRECIOUS METAL**

24057	#1	1.9mm	1.35mm	Tube	14K	Each	\$5.39	\$5.44	\$5.52
24057	#1	1.9mm	1.35mm	Tube	Sterling Silver	Each	\$0.52	\$0.53	\$0.56
24058	#1	2mm	1.37mm	Tube	14K	Each	\$2.90	\$2.93	\$2.98
24058	#1	2mm	1.37mm	Tube	Sterling Silver	Each	\$0.41	\$0.42	\$0.44

**CRIMP BEAD AND TUBE VARIETY PACK**



Order #	Quality	Pcs #0	Pcs #1	Pcs #2	Pcs #3	12+	6+	1+
BEAD								
24143	Silver-Plated	250	150	125	75	\$20.40	\$21.79	\$23.19
24143	Gold-Plated	250	150	125	75	\$20.40	\$21.79	\$23.19
TUBE								
24035	Yellow-Plated	250	150	125	75	\$23.75	\$25.42	\$27.94
24035	Sterling Silver	250	150	125	75	\$23.75	\$25.42	\$27.94



**WIRE GUARDIANS™**

Protect stringing materials from undue wear with Wire Guardians. Reduce abrasion from clasps or other sharp-edged components. Use Wire Guardians in the same way as French wire. The only difference is the Wire Guardian is rigid. For wire diameters up to 0.53mm (0.021").

Item	Order #	Surface Coating	ID	Per Pack	12+	6+	1+
A	38-7171	Silver-Plated	0.022"	20	\$3.03	\$3.29	\$3.65
B	38-7170	Gold-Plated	0.022"	20	\$3.03	\$3.29	\$3.65
C	38-7172	Copper-Plated	0.022"	20	\$3.03	\$3.29	\$3.65
D	24059	14K Yellow	0.021"	20	\$5.68	\$5.77	\$5.93
D	24059	Sterling Silver	0.021"	20	\$0.61	\$0.62	\$0.65



**MYSTERY CLASPS**

Mystery clasps are made to be glued into enlarged drill holes in the end of pearls. The mechanism disappears when the two parts are screwed together.

Item	Order #	Quality	WxL	6+	3+	1+
E	20313	Brass	2mmx6.5mm	\$6.12	\$6.54	\$6.96
E	20313	Nickel-Plated	2mmx6.5mm	\$6.12	\$6.54	\$6.96
F	20312	Brass	2.5mmx7mm	\$6.12	\$6.54	\$6.96
F	20312	Nickel-Plated	2.5mmx7mm	\$6.12	\$6.54	\$6.96





**BEAD BUMPERS**

Use Bead Bumpers instead of knots to separate and add interest to designs strung on Beadalon® wire. Simply string one Bead Bumper in between each bead of a design to space beads evenly. Once incorporated, the Bumpers look similar to a knot and keep the beads from rubbing against one another. Since Bead Bumpers are made of a special stretch material, they can be added to Beadalon® wires up to 0.024" in diameter. Bead Bumpers are also great for memory wire designs and knotted or tin-cup style looks.



**Order # 38-72000**

Color	Shape	Thickness	12+	6+	1+
Black	Oval	1.5mm	\$5.29	\$5.52	\$5.75
Clear	Oval	1.5mm	\$5.29	\$5.52	\$5.75
Silver	Oval	1.5mm	\$6.85	\$7.15	\$7.45
Gold	Oval	1.5mm	\$6.85	\$7.15	\$7.45
White	Oval	2mm	\$5.29	\$5.52	\$5.75
Black	Oval	2mm	\$5.29	\$5.52	\$5.75
Clear	Oval	2mm	\$5.29	\$5.52	\$5.75
Silver	Oval	2mm	\$6.85	\$7.15	\$7.45
Gold	Oval	2mm	\$6.85	\$7.15	\$7.45

**LIGHTWEIGHT BEAD**

Item	Order #	Quality	OD	Hole ID	12+	6+	1+
A	863	14K Gold	3mm	1.5mm	\$2.33	\$2.35	\$2.38
A	863	Sterling Silver	3mm	1.5mm	\$0.78	\$0.80	\$0.84
B	864	14K Gold	4mm	1.45mm	\$0.99	\$4.18	\$4.25
B	864	Sterling Silver	4mm	1.45mm	\$4.14	\$1.01	\$1.06
C	865	14K Gold	5mm	1.45mm	\$6.45	\$6.52	\$6.61
C	865	Sterling Silver	5mm	1.45mm	\$1.52	\$1.55	\$1.62
D	866	14K Gold	6mm	1.8mm	\$11.31	\$11.49	\$11.79
D	866	Sterling Silver	6mm	1.8mm	\$2.11	\$2.15	\$2.24
E	867	14K Gold	7mm	2.2mm	\$2.83	\$13.84	\$14.22
E	867	Sterling Silver	7mm	2.2mm	\$13.45	\$2.88	\$3.01

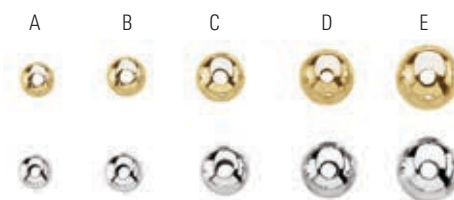

**CRIMP COVERS**

Item	Order #	Quality	OD	12+	6+	1+
F	24056	14K Gold	3mm	\$8.20	\$8.34	\$8.55
	24056	Sterling Silver	3mm	\$0.68	\$0.69	\$0.73
G	24055	Sterling Silver	4mm	\$1.28	\$1.30	\$1.36



**FANCY STERLING SILVER BEAD CAP**

Item	Order #	OD	Hole ID	12+	6+	1+
H	24913	9mm	1.5mm	\$9.46	\$9.97	\$11.00
J	24914	6mm	1.5mm	\$4.97	\$5.25	\$5.81
K	24915	8mm	1.4mm	\$4.86	\$5.11	\$5.62



**SINGLE STRAND PEARL CLASPS**

Item	Order #	Quality	WxL	12+	6+	1+
A	94	Yellow Gold-Filled	5.3x11.1mm	\$5.88	\$5.99	\$6.28
A	94	14K Gold	5.3x11.1mm	\$48.96	\$50.42	\$51.88
A	94	Sterling Silver	5.3x11.1mm	\$6.97	\$7.33	\$7.70
B	101	Yellow Gold-Filled	8x16mm	\$14.64	\$15.47	\$16.31
B	101	Sterling Silver	8x16mm	\$11.42	\$11.65	\$12.20
C	109	14K Gold	5.75x13.5mm	\$74.66	\$77.30	\$81.27
D	22532	Sterling Silver	6x12.25mm	\$5.73	\$5.84	\$6.11
E	102	14K Gold	5.75x12mm	\$68.36	\$70.87	\$74.65
F	23373	14K Gold	5.3x11.1mm	\$50.33	\$51.86	\$53.39



**ROUND MAGNETIC CLASP WITH RINGS**

Item	Order #	Quality	WxL or Diameter	12+	6+	1+
G	24283	Sterling Silver	7mm (diameter)	\$15.19	\$15.49	\$15.94
H	28506	Sterling Silver	5mmx15.5mm	\$7.53	\$7.68	\$7.91
	28506	14K Gold	4.3mmx15.5mm	\$46.36	\$46.68	\$49.22
J	28294	Sterling Silver	6mm (diameter)	\$25.40	\$25.90	\$26.66
	28294	14K Vermeil	6mm (diameter)	\$34.01	\$34.70	\$35.74
K	28293	Sterling Silver	5.5mm (diameter)	\$25.39	\$25.89	\$26.64
	28293	14K Vermeil	5.5mm (diameter)	\$34.01	\$34.70	\$35.74
L	24314	14K Gold-Plated	8mmx25mm	\$30.59	\$30.93	\$33.62
	24314	Silver-Plated	8mmx25mm	\$28.60	\$28.91	\$31.42
M	24313	Sterling Silver	7.3mmx19mm	\$55.11	\$58.87	\$62.63
	24313	Sterling Silver	7.3mmx19mm	\$42.12	\$42.58	\$46.28
N	22485	Sterling Silver	5.5mmx21.25mm	\$27.34	\$27.84	\$28.57
	22485	Sterling Silver	4.5mmx20.25mm	\$25.71	\$26.19	\$26.91



**LINK LOCK™**

**Order # 20999**

Quality	mm ID	mm OD	Thickness	12+	6+	1+
14K Gold	2.25 4.25	5x8	1.2mm	\$27.18	\$28.26	\$29.33
Sterling Silver	5x8	5x8	1.2mm	\$6.07	\$6.42	\$6.90



Securely attach charms or dangles without soldering using the rotating crimp collar on the Link Lock™

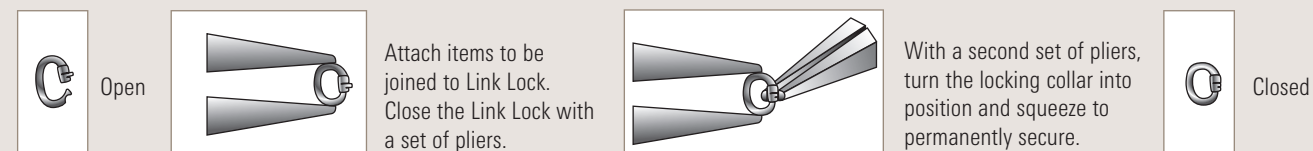



**ROUND SPLIT RING**

Item	Order #	Description	OD	Thickness	12+	6+	1+
A	RD1	Sterling Silver	5mm	1mm	\$0.78	\$0.79	\$0.83
	RD1	14K	5mm	1mm	\$13.03	\$13.41	\$13.79
	RD1	Yellow or White Gold-Filled	5mm	1mm	\$1.33	\$1.35	\$1.38
B	RD2	Sterling Silver	5mm	1mm	\$1.58	\$1.61	\$1.69
	RD2	14K	6.5mm	1mm	\$22.14	\$22.47	\$23.01
C	RD3	Sterling Silver	7.5mm	1.5mm	\$1.55	\$1.61	\$1.65
	RD3	14K	7.5mm	1.5mm	\$35.93	\$37.18	\$38.42
	RD3	Yellow or White Gold-Filled	7.5mm	1.5mm	\$1.91	\$1.94	\$2.40



**MICRO MINI PLIERS**

These pliers are a great choice for product assembly or bead stringing. To open split rings, insert the tooth on the side of the ring and squeeze gently.

Order #	Description	Length	12+	6+	1+
46-3070	Split Ring Pliers	5¼"	\$7.78	\$8.24	\$9.15



**SPLIT RING TWEEZERS**

Easy-to-use tweezers open small to medium split rings. Just put the split ring under the claw and squeeze. They are made of stainless steel.

Order #	Description	Length	12+	6+	1+
57-7640	Split Ring Tweezers	4½"	\$4.21	\$4.46	\$4.95



**S-HOOKS**

Item	Order #	Metal Type	Width	Length	12+	6+	1+
D	23860	Sterling Silver	7.75mm	17.75mm	\$8.35	\$8.50	\$8.88
E	23853	Sterling Silver	10.75mm	18.5mm	\$10.55	\$10.74	\$11.22
F	23822	Sterling Silver	6mm	15.5mm	\$30.08	\$30.69	\$32.22

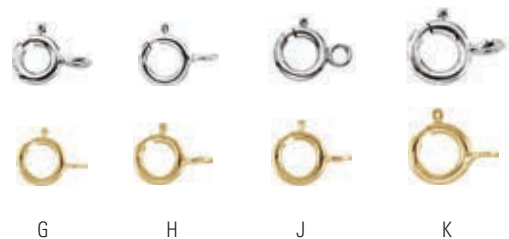

**SPRING RINGS WITH SEAMLESS OPEN RING**

Item	Order #	Metal Type	Width	Ring ID	12+	6+	1+
G	SR5	Sterling Silver	5mm	1.4mm	\$2.31	\$2.35	\$2.47
	SR5	Yellow Gold-Filled	5mm	1.4mm	\$2.46	\$2.58	\$2.75
H	SR5.5	Sterling Silver	5.5mm	1.1mm	\$2.44	\$2.49	\$2.61
	SR5.5	Yellow Gold-Filled	5.5mm	1.1mm	\$2.27	\$2.38	\$2.53
J	SR6	Sterling Silver	6mm	1.5mm	\$2.79	\$2.84	\$2.98
	SR6	Yellow Gold-Filled	6mm	1.5mm	\$2.36	\$2.45	\$2.59
K	SR7	Sterling Silver	7mm	1.4mm	\$3.18	\$3.25	\$3.40
	SR7	Yellow Gold-Filled	7mm	1.4mm	\$3.49	\$3.65	\$3.87



**JUMBO SPRING RINGS WITH CLOSED RING**

Item	Order #	Metal Type	Width	Length	Ring ID	12+	6+	1+
L	22467	Sterling Silver	12.75mm	20.5mm	3.6mm	\$21.95	\$22.36	\$23.39
M	22467	Sterling Silver	14.75mm	24.25mm	3.6mm	\$25.53	\$26.01	\$27.21
N	22467	Sterling Silver	16.5mm	25mm	3.6mm	\$26.15	\$26.63	\$27.85
P	22467	Sterling Silver	20mm	31mm	3.6mm	\$44.84	\$45.68	\$47.81

**BEADING KIT**

Our beading kit contains the essential tools and supplies for the beginning beader, including pliers, tools, design board, and instruction book.

**Basic Beading Kit includes —**

- Bead Board
- #5 Beading Tweezer
- Beading Awl
- Basic Beading Instruction Book
- 80mm Brass Gauge
- 4½" Chain Nose Pliers
- 4½" Round Nose Pliers
- 4½" Sidecutter
- Thread Scissors

Order #	Description	12+	6+	1+
38-9022	Basic Beading Kit	\$32.47	\$34.38	\$38.20



**FLOCKED BEAD BOARDS**

Help in keeping design objects in place. Recessed storage bins are perfect for organizing beads, findings, and stringing material.

Item	Order #	Description	W×L	12+	6+	1+
A	38-1009	Mini Travelers Board with Cover	7¾"×11¼"	\$5.82	\$6.17	\$6.85
B	38-1010	U-Shaped Travelers Board with Cover	9¾"×13¼"	\$5.91	\$6.26	\$6.95
C	38-1008	Multi-Strand Bead Board	10"×20½"	\$9.48	\$9.89	\$10.30
D	38-1011	Bead Board with 3 Channels (6 bin)	9"×19"	\$5.99	\$6.35	\$7.05
E	38-1007	Bead Board with 3 Channels	8"×19"	\$7.35	\$7.79	\$8.65
F	38-1012	Bead Board	10½"×19"	\$4.34	\$4.59	\$5.10
G	38-1005	4-Row Straight Board	8"×21"	\$4.89	\$5.18	\$5.75

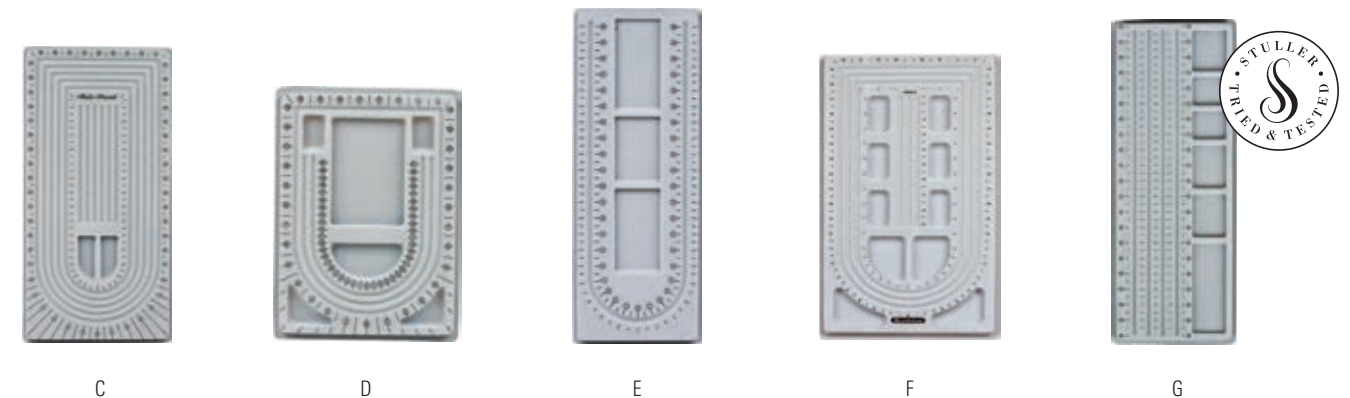
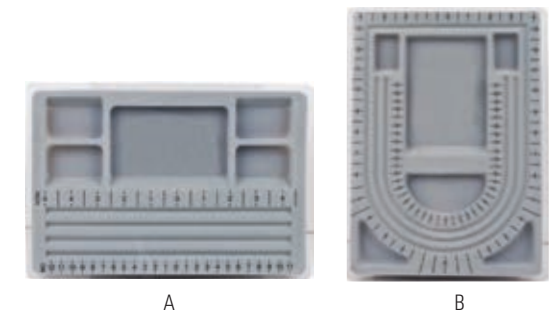

**BEADALON® BEAD BOARD WITH CASE**

The flocked gray surface reduces eyestrain and helps keep objects in place. Recessed storage bins are perfect for organizing beads, findings, and stringing materials. Graduated beading channels are essential for designing multi-strand necklaces and bracelets.

Item	Order #	Description	W×L	12+	6+	1+
H	38-1015	Bead Board with Case	9"×19"	\$10.75	\$12.28	\$15.35
	38-1016	Case Only	9"×19"	\$8.02	\$9.16	\$11.45







**STONE SORTING TRAY**

Use for sorting stones by size. Has grooves of various sizes for easily sorting stones. Made of solid, tough, unbreakable plastic.

Order #	Description	W x L	12+	6+	1+
38-1000	Stone Sorting Tray	8 1/2" x 5 1/2"	\$4.92	\$5.14	\$5.35



**BEAD BOARD**

Use this black wooden board to align beads prior to stringing. Contains perfectly spaced grooves for work organization.

Order #	Description	W x L	12+	6+	1+
38-1001	Wood Stringing Board	3 3/4" x 13 1/2"	\$6.93	\$7.52	\$8.35



**SORTING TRAYS**

Grooved trays are used for sorting pearls, stones, and findings. Also has round indentations for size sorting as well.

Item	Order #	Description	W x L	12+	6+	1+
A	38-1002	Black Sorting Tray	7" x 3 3/4"	\$4.44	\$4.82	\$5.35
B	38-1003	Black Sorting Tray	7" x 3 3/4"	\$4.44	\$4.82	\$5.35

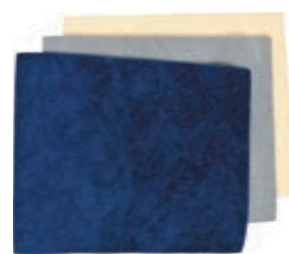

**BEAD MAT**

Soft comfortable bead mats keep small parts from rolling around and cushion hands while stringing beads.



Order #	Description	W x L	12+	6+	1+
38-1006	3-Piece Set: Beige Blue Gray	9" x 12"	\$2.90	\$3.02	\$3.15



**BEADALON® TACKY BEAD MAT**

The Beadalon® Tacky Bead Mat is a sticky mat that keeps beads and pieces in place while you're working. It does not leave a sticky residue when you remove items from the mat. If the mat gets dirty, simply recharge it by washing it under warm water until clean. Let dry, and it's ready and sticky again. Measures 4.25 by 4.25 inches (10.8 by 10.8 centimeters).

Order #	Description	W x L	12+	6+	1+
38-1013	Tacky Bead Mat	4 1/2" x 4 1/2"	\$5.82	\$6.17	\$6.85

**TRI-CORD™ BEADING KIT**

The professional knotting tool kit comes with everything you need to get started in the craft of classic pearl knotting, beading, and bead stringing, as well as the profitable jewelry repair industry. With just a few short hours of self-learning with the instructional DVD help provided, your investment will quickly pay for itself.

Item	Order #	Description	12+	6+	1+
A	38-0190	Tri-Cord™ Beading Kit	\$91.03	\$94.99	\$98.95



**TRI-CORD™ TIN-CUP KNOTTER®**

B. The Tin-Cup knotting tool is for knotting a bead or beads and other components with a space in between each group, known as a station in the jewelry industry. These stations can be a single pearl with a knot on each side separated by 3/8" or more between each station. They can be any combination of components separated by the silk cord or even links of chain, creating unique artistic designs in pearl, metal, stone, and crystal beads.

**TRI-CORD™ PROFESSIONAL KNOTTING TOOL®**

C. Knot faster and with more consistency. The revolutionary Tri-Cord Knotter does the work of an awl and tweezers in one easy-to-use tool. Once your strand is started, you can string on all beads and knot quickly and continually, creating knots that are tight, consistent, and have the professional appearance your customers expect.

Item	Order #	Description	12+	6+	1+
B	38-0193	Tin-Cup Knotter	\$43.82	\$46.40	\$51.55
C	38-0192	Knotting Tool	\$38.25	\$40.50	\$45.00



**STRINGING WITH THE TRI-CORD™ KNOTTER**

It's fast and easy to create professional quality knots with this convenient tool. Simply make a loop, pick it up with the knotters awl, move the knot down to the bead, and release (instructions included). You get tight, consistent knots in a fraction of the time it would take with the conventional awl-and-tweezers stringing method!

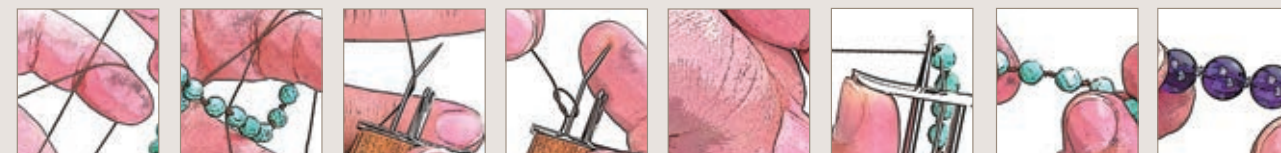

**BEADALON® BEADING TOOL**

The Beadalon Knotter Tool allows you to create tight, consistent knotted strands. This economy tool does the work of an awl and tweezers in one easy-to-use tool. Complete with illustrated instruction book.

Item	Order #	Description	Length	12+	6+	1+
D	38-0194	Beadalon Beading Tool	5"	\$27.58	\$29.21	\$32.45





**PERFECT END THREAD BURNER**

End the fray. Why didn't someone think of this before? Perfect for stopping frayed ends of thread on embellishments, peyote stitch, or anywhere raw ends need to be eliminated. Cuts and cauterizes. Fact is that the tip heats to red hot at the touch of a button and melts synthetic threads so that they don't unravel. Powered by one AA battery (included).

Order #	Description	12+	6+	1+
21-2603	Perfect End Thread Burner	\$23.38	\$24.75	\$27.50



**DRAWERS**

Fill these handy drawers with all different types of findings, stringing materials, solder chips, and anything else needed for different jobs. Then, when it's time to do the job, simply get the drawers of product you need, attach them together and all the supplies stay neatly organized. Kit includes 10 drawer units that connect in two different directions-side to side or top to bottom.

Order #	WxL	12+	6+	1+
15-2059	1" x 1 3/4"	\$4.34	\$4.59	\$5.10



**ORGANIZATION TRAYS**

Durable, clear plastic storage boxes with fixed compartments.

Order #	# of Compartments	WxLxH	12+	6+	1+
15-2066	18	8 1/4" x 1 1/4" x 4 1/4"	\$6.26	\$6.53	\$6.80
15-2067	12	8 1/4" x 1 1/4" x 4 1/4"	\$6.03	\$6.29	\$6.55
15-2068	18	11" x 1 3/4" x 6 1/2"	\$8.28	\$8.64	\$9.00
15-2069	36	10" x 1 1/2" x 7"	\$9.20	\$9.60	\$10.00



**ORGANIZATION TRAYS**

High-impact, plastic utility boxes are convenient for storing small items. Adjustable partitions are removable and allow for a variety of compartment sizes. Contents are easily identified with see-through lid, which securely snaps closed.

Order #	# of Compartments	WxLxH	12+	6+	1+
15-2060	6	4 1/2" x 1 1/8" x 3"	\$2.30	\$2.40	\$2.50
15-2062	18	11" x 2 1/8" x 7"	\$8.33	\$8.69	\$9.05
15-2063	18	8" x 7" x 2 1/8"	\$4.92	\$5.14	\$5.35



A

B

**ORGANIZATION TRAYS AND VIALS**

Paper-covered trays feature magnetic closure and a clear view lid. Vials have swing-top lids. Small bottle: 6mm hole, Large bottle: 10mm hole

Item	Order #	Description	WxLxH	12+	6+	1+
A	59-2105	Black Tray (36 black vials)	6" x 9 1/2" x 1"	\$18.49	\$19.30	\$20.10
B	59-2115	Black Tray (24 lime green vials)	5 3/4" x 10 1/4" x 1 1/4"	\$22.72	\$23.71	\$24.70
C	59-2100	Small Plastic Vial with Black Lid	1/2" x 1 1/2"	\$0.60	\$0.62	\$0.65
D	59-2110	Large Plastic Vial with Lime Green Lid	7/16" x 1/2"	\$0.92	\$0.96	\$1.00



C

D

**STACKABLE ROUND TRAYS**

These convenient, space-saving trays have threaded bottoms that securely screw to the tray below, allowing access to any tray at any level. Translucent plastic.

Item	Order #	Diameter	Per Pack	12+	6+	1+
E	38-9006	2"	6	\$3.32	\$3.51	\$3.90
F	38-9008	1 1/4"	6	\$2.51	\$2.66	\$2.95



E

F

**ORGANIZATION TRAYS**

Tan plastic tray with slide lid allows for smooth opening and closing operations and keeps parts in place. A wide variety of parts and small objects can be stored. The front edge of each compartment is rounded, making the contents easily retrievable.

Item	Order #	# of Compartments	WxLxH	12+	6+	1+
G	15-2070	18	10 1/2" x 6 3/4" x 1 1/2"	\$10.21	\$10.66	\$11.10
	15-2071	24	7 3/4" x 5" x 1"	\$10.21	\$10.66	\$11.10



G



**BLACK KIT WITH VIALS**

Black, paper-covered trays with magnetic closure and vials.

**Order # BOX3**

Description	W×L×H	12+	6+	1+
24-Slot	9 <sup>7</sup> / <sub>8</sub> "×4 <sup>1</sup> / <sub>2</sub> "×1 <sup>1</sup> / <sub>8</sub> "	\$16.65	\$17.38	\$18.10
36-Slot	10"×6 <sup>5</sup> / <sub>8</sub> "×1 <sup>1</sup> / <sub>8</sub> "	\$20.01	\$20.88	\$21.75
60-Slot	10"×10 <sup>1</sup> / <sub>4</sub> "×1"	\$22.26	\$23.23	\$24.20
72-Slot	9 <sup>7</sup> / <sub>8</sub> "×12 <sup>1</sup> / <sub>4</sub> "×1 <sup>1</sup> / <sub>4</sub> "	\$31.17	\$32.52	\$33.88
Replacement Vials	1"	\$0.09	\$0.10	\$0.10



**UTILITY CABINET**

This 60-drawer utility cabinet features a one-piece polystyrene frame, crystal styrene drawers, key hole slots for wall mounting. Drawer dimensions are 2 1/4" W x 1 3/8" H x 6" D.

Order #	Description	Cabinet: W×D×H	12+	6+	1+
<b>15-2065</b>	60 Drawer Utility Cabinet	14 <sup>7</sup> / <sub>8</sub> "×6 <sup>3</sup> / <sub>8</sub> "×18 <sup>1</sup> / <sub>2</sub> "	\$33.45	\$35.42	\$39.35

**PRO ELECTRIC BEAD REAMER**

Compact, lightweight design makes it perfect for smoothing rough edges of beads and enlarging bead holes. Includes three diamond-coated tips: small reamer, large reamer, and 45° edge reamer. Variable speed control: 1,000-20,000 rpm. 24V DC.

Item	Order #	Description	12+	6+	1+
A	<b>38-9019</b>	Motorized Bead Reamer	\$20.19	\$21.38	\$23.75
B	<b>53-0201</b>	Short Tip	\$1.87	\$1.98	\$2.20
C	<b>53-0202</b>	Long Tip	\$1.87	\$1.98	\$2.20
D	<b>53-0203</b>	45° Diamond Tip	\$1.87	\$1.98	\$2.20



**BATTERY-OPERATED BEAD REAMER**

This bead reamer is designed to enlarge holes in pearls, gemstones, and other beads. Simply submerge the bead and reamer tip into a small amount of water and apply to the bead hole. Sold with two tips. Batteries not included.

Item	Order #	Description	12+	6+	1+
E	<b>38-3101</b>	Battery-Operated Bead Reamer	\$22.48	\$23.81	\$26.45
F	<b>38-3102</b>	Replacement Tips (pack of 2)	\$4.68	\$4.95	\$5.50

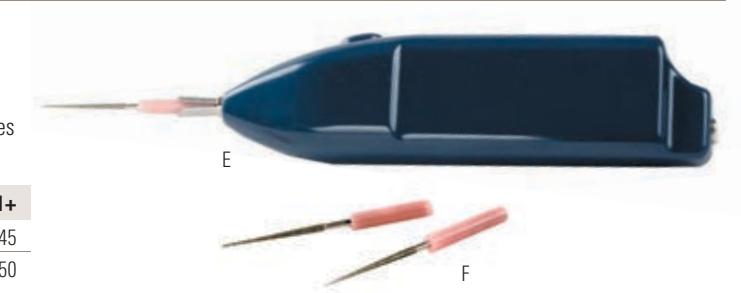

**DELUXE BEAD REAMER**

This Diamond Bead Reamer Set includes three points (small and large reaming points plus 45° edge reamer). Handle is hollow, so you won't lose the diamond points. Just store them in the handle. Easy-release chuck fits into the aluminum housing, so it releases instantly when the collet is unscrewed. Handle is anodized aluminum with a cushion PVC grip for comfort. Chuck is brass, so rust is never a problem.

Item	Order #	Description	12+	6+	1+
G	<b>53-0200</b>	Bead Reamer Set with Comfort Grip	\$16.02	\$16.97	\$18.85
H	<b>53-0201</b>	Short Tip	\$1.87	\$1.98	\$2.20
J	<b>53-0202</b>	Long Tip	\$1.87	\$1.98	\$2.20
K	<b>53-0203</b>	45° Diamond Tip	\$1.87	\$1.98	\$2.20



**BEADING AWL DESIGNER WITH PVC GRIP**

Deluxe, rubberized handle helps control tip placement for hand knotting and opening small beads for covering crimps.

Order #	Length	12+	6+	1+
<b>38-3100</b>	5 3/4"	\$5.78	\$6.12	\$6.80



**STRINGING AWL**

Designed to slide a knot down into the bead tip or between two beads. Can also be used for cleaning holes.

Order #	Length	12+	6+	1+
<b>38-3300</b>	5 3/4"	\$2.81	\$2.97	\$3.30



**WOODEN BEAD HOLDER**

A handy tool for bead stringing, this wooden vise securely holds delicate beads while cleaning or reaming holes.

Order #	Length	12+	6+	1+
<b>53-0215</b>	6 3/4"	\$5.61	\$5.94	\$6.60





**FOUR-IN-ONE PLIERS**

With PVC grips and double-leaf springs, these pliers are our Four-In-One Beader's Delight. A must-have for wire wrappers, these pliers have a finely tapered long nose for coiling; a flat jaw for flattening, straightening, or bending; a groove for closing coils and jump rings; and a sidecutter. They are great for travel.

Order #	Description	Length	12+	6+	1+
46-4017	Beading Plier	5"	\$9.35	\$9.90	\$11.00



**MICRO-MINI BEAD KNOT PLIERS**

This pair of pliers is used when knotting bead cord, as knotted cord slides off of this finely tapered nose. These pliers are easier to use than tweezers, especially when using heavier bead cord.

Order #	Description	Length	12+	6+	1+
46-4006	Beading Plier	5"	\$8.80	\$9.32	\$10.35



**MICRO MINI/FLAT NOSE PLIERS**

Use these reasonably priced stainless steel pliers for delicate tasks.

Order #	Description	Length	12+	6+	1+
46-9003	Flat Nose Plier	5"	\$6.12	\$6.48	\$7.20



**XURON® HIGH PRECISION SCISSORS**

Ultra-precise, the Xuron scissor cuts fine or delicate items with a clean, square-edge cut. Cushion grips and return spring provide increased comfort and precision. Rated for cutting soft metals up to 0.005" or materials such as silk, embroidery, floss, or thin mylars.

Order #	Description	Length	Jaw Length	12+	6+	1+
46-0508	Scissor	5"	0.47"	\$14.96	\$15.84	\$17.60



**XURON® HIGH DURABILITY SCISSORS**

Features precision-ground high carbon steel cutting edges. Excellent for cutting solder and sheets of light gauge metal up to 0.030" (0.8mm). For line and all bead cords, these pliers have serrations on one edge to keep material secure while cutting.

Order #	Description	Length	Jaw Length	12+	6+	1+
46-0513	Scissor	6"	0.85"	\$18.70	\$19.80	\$22.00



**PRECISION SCISSORS**

Use for beading and other delicate work. Handles are large and made of black ABS. Small, pointed blades are made of high-quality stainless steel. Blades are held together with a stainless steel high-impact rivet and nylon washer, which provide smooth cutting and extended life.

Order #	Description	Length	12+	6+	1+
53-6200	Beading Scissor	4"	\$11.05	\$11.70	\$13.00



**MICRO-SNIP BEADING SHEARS**

Ideal for use in bead stringing and thread snipping.

Order #	Description	Length	12+	6+	1+
53-2800	Shear	3½"	\$3.74	\$3.96	\$4.40



**BEADALON® SNIPPER TOOL**

These compact snips have precision tips to make close cuts easy. Built for efficiency, these new snips look good and can cut silk cord, nylon, nymo, and most other non-metal stringing materials with ease. Always-ready blades are extremely sharp and hold their edge. The secure blade cover prevents accidental holes.

Order #	Description	Length	12+	6+	1+
53-2801	Snipper	4½"	\$3.40	\$3.60	\$4.00

**PRECISION SCISSORS**

These cutters are specifically designed for multi-strand beading wire and full-flush with jaws induction hardened to 60-62 Rockwell. Used properly, this degree of hardness assures a clean cut time after time. Cutting edges are precisely aligned and the black oxide, non-glare head has a relieved design for reaching into tight areas. This quality German cutter also features double-leaf spring and yellow PVC handles. Use on flexible beading wire and soft wire only.



Order #	Description	Length	12+	6+	1+
46-4013	Cutter	4½"	\$21.25	\$22.50	\$25.00
46-4014	Pointed Jaw Cutter	4½"	\$26.35	\$27.90	\$31.00

**DURSTON JUMP RING MAKER**

Quickly fabricate the jump ring you need. Durston's Jump Ring Maker features 20 different mandrel sizes, and it works seamlessly with both Dremel® and Foredom® flex shafts. The new, high steam coiler provides more room for your hands, allowing you to work with speed and comfort. Special features include the following:

- Coil holder with screws to bolt down to your bench for safety.
- Two different size V Grooves in Coil Holder.
- Increased mandrel length (120mm long) and increased coil holder length.
- High steam coiler enabling more room for your hands.
- Coil winder can be bolted anywhere to your bench or to the tray provided.
- 20 mandrel sizes.
- Compact base measures 110 x 185 x 155 high.
- Durston lubricant and one blade supplied as standard
- Suitable for both Dremel® and Foredom® flex shafts.



Order #	W x L x H	12+	6+	1+
48-7514	110"×185"×155"	\$212.50	\$225.00	\$250.00





**PATTERN #7 TWEEZERS**  
 Pattern #7 is excellent for handling all miniature and micro-miniature parts and components. Curved shanks have beveled edges and points are very sharp.

Order #	Description	Length	12+	6+	1+
57-0420	Dumont II Stainless Steel	4½"	\$34.00	\$36.00	\$40.00



**PATTERN #5 BEAD TWEEZERS**  
 Pattern #5 is used for handling microscopic parts and delicate knotting work. Has very narrow, needle-like points honed to extreme sharpness. Shanks are indented with beveled edges. Non-magnetic.

Order #	Description	Length	12+	6+	1+
57-5030	Dumont II Stainless Steel	4½"	\$28.05	\$29.70	\$33.00



**PEARL-HOLDING TWEEZERS**  
 Tips are epoxy coated and will not damage pearls.

Order #	Description	Length	12+	6+	1+
57-6013	Holding Tweezers	5½"	\$10.16	\$10.76	\$11.95



**DIAMOND TWEEZERS WITH SCOOP**  
 These diamond tweezers feature fine, serrated points and ribbed shanks.

Order #	Description	Length	12+	6+	1+
57-7660	Tweezers with Scoop	7"	\$3.36	\$3.56	\$3.95



**SPLIT RING TWEEZERS**  
 Easy-to-use tweezers open small to medium split rings. Just put the split ring under the claw and squeeze. They are made of stainless steel.

Order #	Description	Length	12+	6+	1+
57-7640	Split Ring Tweezers	4½"	\$4.21	\$4.46	\$4.95



**ECONOMY TOOL KIT**  
 This economy tool kit with zip pouch comes complete with all the tools you need to begin beading. It features chain nose pliers, round nose pliers, wire cutters, tweezers, a bead scoop, snips, and six modular and stackable drawers; all zipped into a handy storage pouch. The complete kit is ready to travel and keeps tools neatly organized. Store various findings and beads in the drawers.

Order #	Description	12+	6+	1+
46-0516	7-Piece Repair Kit	\$13.09	\$13.86	\$15.40

**MINI TOOL KIT**  
 This set of mini tools is perfect for quick repairs and for travel. Contains all the tools necessary for wire wrapping and other stringing functions. These mini tools are 3" long. Set is complete with chain nose pliers, round nose pliers, flat nose pliers, fiber tipped pliers, and a cutter all zipped up into the pouch.

Order #	Description	12+	6+	1+
46-0515	5-Piece Repair Kit	\$11.22	\$11.88	\$13.20



**EURO CRIMPER**  
 Incorporates two medium crimping cavities to fit all of the crimp tubes and beads within the medium range. Each cavity is slightly larger (or smaller) than the other to give the user the ability to tighten the crimp properly. Works great on Beadalon #1 and #2 Crimp Beads or #2 Crimp Tubes, as well as other non-standard crimp bead and tube sizes.

Order #	Description	Length	12+	6+	1+
46-3995	Crimping Plier	5"	\$14.03	\$14.85	\$16.50



**THE #1 CONNER BEAD SETTING PLIERS**  
 The right tool for securing Beadalon #1 Crimp Tubes and sizes #0 and #1 Crimp Beads. Use one firm squeeze to crimp with the inner-position grooves. Then use the outer-position grooves to round off the crimp. The jaw grooves are comparably smaller to make a dependable closure on smaller crimp findings.

Order #	Description	Length	12+	6+	1+
46-4007	Crimping Plier	5"	\$11.90	\$12.60	\$14.00



**MICRO CRIMPER**  
 Close and secure Beadalon® Crimp Beads and Crimp Tubes with this easy-to-use hand tool. Inner-position grooves crimp beads and tubes tightly closed with one firm grip. Outer-position grooves round off edges on Crimp Beads for a smooth, professional result. Use with Beadalon #1 and #2 Crimp Beads or #2 Crimp Tubes.

Order #	Description	Length	12+	6+	1+
46-4005	Crimping Plier	5"	\$11.18	\$11.84	\$13.15



**BEADALON® POCKET NIPPER TOOLS**  
 A compact and ergonomic tool, the Beadalon® Pocket Nipper gives you a clean and close cut when cutting soft beading wires. This rivet joint cutter features a single leaf spring construction and plastic-molded handle.

Order #	Description	Length	12+	6+	1+
46-3997	Pocket Nipper Tools	4"	\$4.21	\$4.46	\$4.95





# BENCHES



26-5101  
Acrobat® Versa & Leica®

### SWISS-MADE DELUXE JEWELER'S BENCH

This Swiss Deluxe jeweler's bench integrates all of your favorites into one convenient package. It starts with a hardwood top and fully adjustable metal base. The integrated dust collection system takes it to the next level. It is also equipped with a bench pin, footrest, bench pan, and an LED light with rheostat.

Order #	Description	1+
13-0455	Deluxe Bench	\$8,495.00



35-1237  
NSK Micro motor Kit



26-1806  
The RinGenie™ Vise

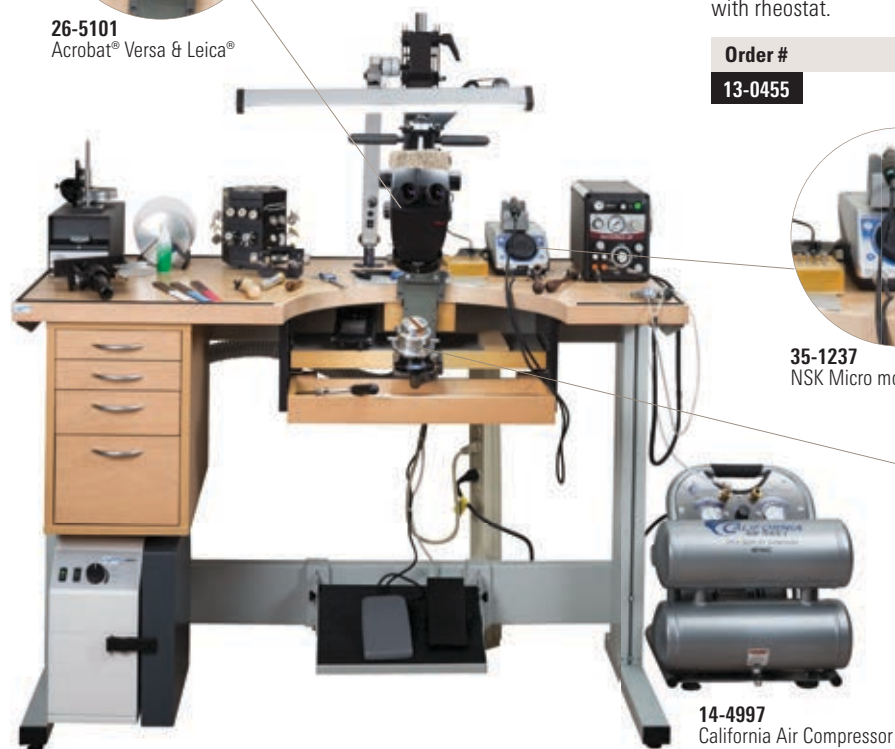

14-4997  
California Air Compressor

All items shown on bench are sold separately.



### SWISS-MADE STANDARD JEWELER'S BENCH

This Swiss-Made jeweler's bench features a hardwood top with a fully adjustable metal base. The convenient five-drawer storage cabinet and shelf is ready to keep you organized. This bench comes equipped with a bench pin, footrest, bench apron, and an LED light with rheostat.

Order #	Description	1+
13-0455	Standard Bench	\$6,495.00

## CUSTOMIZE YOUR BENCH

Among the most sought-after benches on the market anywhere, these premium Swiss Jeweler's Benches offer easy-to-adjust seating as well as a host of outstanding features originally designed to satisfy unique jewelers and watchmakers. These features include raised rubber inserts on the bench top that prevent dropped items, a unit of high-quality metal drawers for small tools and components, and much more. Most impressively, you can customize the bench to fit your needs and tastes by choosing accessories and configuring the base, top, and drawers. If you have questions or want to learn more about our benches, contact our Tools Tech Team at 800-877-7777, ext. 4300.

1



Adjustable Base

### CHOOSE YOUR BASE

You can pick either a standard or adjustable base, with each option coming in two different sizes.

2



Butcher Block Top

### CHOOSE YOUR TOP

You can choose either a laminate top or a solid beechwood top. Either top comes in two sizes, corresponding the two different base sizes.

3



Contoured Drawer

### CHOOSE DRAWER TYPE AND QUANTITY

There are 12 different drawer variations to choose from, depending on the number of drawers you would like and the size of the individual drawers. You can also choose whether the drawer cabinet should sit on the ground or be elevated on a small shelf.

4



Foot Rest

### CHOOSE YOUR ACCESSORIES

You can choose to add a number of accessories. These include an integrated dust collection system, an LED light with a rheostat dimmer, a footrest, and a choice of bench pan or leather apron.





**JEWELER'S WORKBENCH**

This genuine, solid wood, heavy-duty bench has no pressboard and no particle board. Features a solid wood top with all wood legs and full skirt, three assembled utility drawers, pull-out tray with two shelves, two-arm rests, and a lined catch drawer.

Order #	W×H×D	1+
<b>13-0449</b>	39"×39"×19½"	\$299.00

**SPECIAL FEATURES**

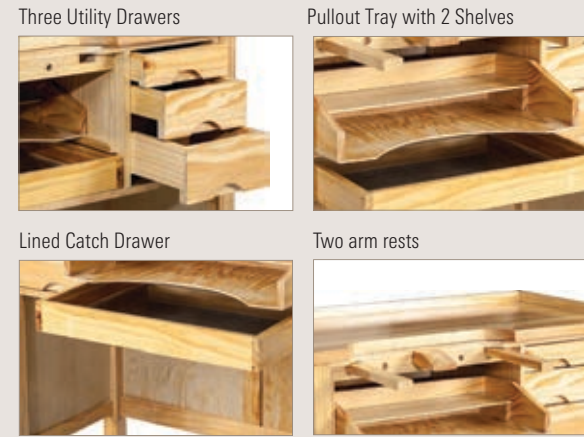

**JEWELER'S BENCH WITH SURELL® SURFACE**

This all-wood constructed workbench has a solid Surell surface, which is heat-resistant and easy to maintain. Light sanding will remove burns, stains, or minor scratches. It is fully-skirted, and its quality hardwood construction will withstand the rigors of daily use. Other features include two side drawers and two arm rests. No assembly required. Made of solid wood in the USA.

Order #	W×H×D	1+
<b>13-0436</b>	37" × 39½" × 19½"	\$850.00

**SPECIAL FEATURES**

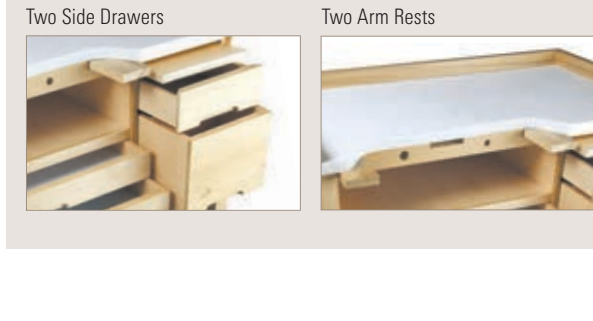

**JEWELER'S WORKBENCH**

Well-constructed jeweler's workbench features all wood with hardwood top, three drawers on the right-hand side, a pull-out utility tray with two shelves, fully skirted legs and back, two arm rests, steel-lined drawer pan, and pre-drilled mandrel holes. No assembly required. Made of solid wood in the USA.

Order #	W×H×D	1+
<b>13-0430</b>	38¾"×39"×19¼"	\$835.00

**SPECIAL FEATURES**

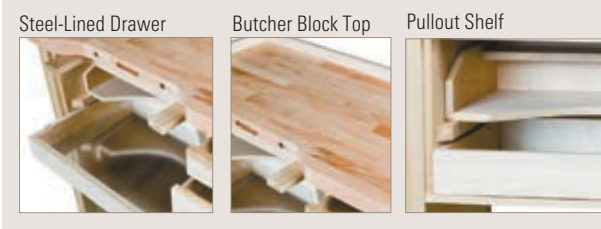

**PREMIER WORKBENCH**

This well-crafted, all-wood bench is built to last. It has a solid hardwood work surface with reinforced side railings and fully skirted sides and rear. Features seven side drawers, two top drawers with security locks, a formica-lined drawer, three steel-lined drawers, catch drawers, right and left arm rests, slot for bench pin, and layout shelf. No assembly required. Made of solid wood in the USA.

Order #	W×H×D	1+
<b>13-0438</b>	48½"×40"×21"	\$1,340.00

**SPECIAL FEATURES**





**SHELFMATE TOOL HOLDER**

Keep your tools handy and organized while increasing your workspace. Store pliers, shears, and other tools within reach. Easy to assemble. Instructions included.

Item	Order #	W×H×D	1+
A	13-0460	35"×17"×7"	\$59.95



**MAGNETIC TOOL HOLDER**

Pliers, screwdrivers, and other miscellaneous metal tools are held securely in place with permanent magnets. Mounts with screws.

Item	Order #	Length	1+
B	13-3800	12"	\$25.40



**WOODEN PLIERS CABINET**

Ideal for hobbyists, jewelers, or watch makers to place on work bench. Holds seven pliers, a shelf for tools, and a storage drawer.

Item	Order #	W×H×D	1+
C	13-3760	6½"×5"×7½"	\$15.75

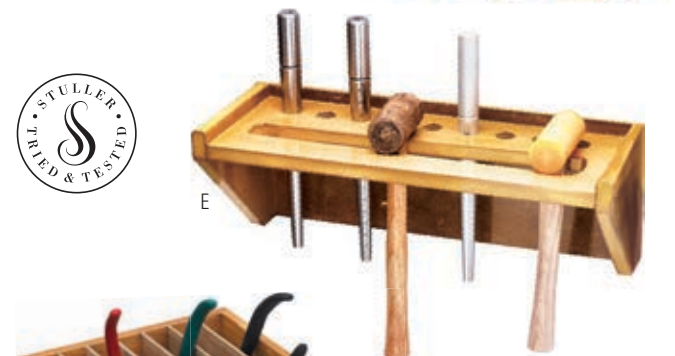

**BENCH TOP ORGANIZER**

Fits perfectly on the back of a bench or a work table. Contains space for findings, tools, and accessories and organizes it all. Four drawers are included for stowaway items. A great compliment to any work area.

Item	Order #	W×L×H	1+
D	13-3765	5"×18"×3½"	\$51.75



**MANDREL AND HAMMER ORGANIZER**

This organizer can be attached to a workbench.

Item	Order #	W×H×D	1+
E	13-3766	18"×6½"×7"	\$66.35



**WOODEN PLIERS RACK**

This rack has slots for seven pliers, a shelf for small tools, and a handy storage drawer in a natural, varnished finish.

Item	Order #	W×H×D	1+
F	13-3771	7"×3¾"×7½"	\$21.80



Find added video content on [Stuller.com/VideoCenter](http://Stuller.com/VideoCenter).

**SADDLE SEAT**

This deceptively comfortable setter's seat is a thoroughly ergonomic design. It adjusts the hips and knees to a 135° angle rather than the 90° angle of a traditional chair. It is fully adjustable to suit the user's height and tilt preferences, and will create healthier feeling back, neck, and legs.

Item	Order #	Description	Height	1+
A	13-0517	Saddle Seat	35"	\$299.00



**JEWELER'S BENCH CHAIR**

This ergonomic bench chair is designed for jewelers and watchmakers. Constructed to provide years of comfort while greatly improving productivity and reducing fatigue, it features single touch adjustments to provide independent control of the seat, backrest, and lumbar height. Category 2 Castillo Metal.

Item	Order #	Description	Height	1+
B	13-0510	Jeweler's Chair	16 - 21¼"	\$321.13



**SETTER'S CHAIR**

This ergonomic jeweler's chair is designed to provide comfort and reduce fatigue. Single touch adjustments provide independent control of the seat, backrest, and lumbar height. The seat is adjustable from 16" to 21" by a convenient foot control.

Item	Order #	Description	Height	1+
C	13-0516	Setter's Chair	37"	\$295.00





# BENCH TOOLS



Find added video content on [Stuller.com/VideoCenter](http://Stuller.com/VideoCenter).

### EARRING SETTING TOOL

This unique earring setting tool allows you to keep a good grip on a basket earring during the setting process. This tool is made of lightweight aluminum and brass and has a .43mm x 1/2" deep hole for the earring post to sit in. The earring setting tool is easy to use. First, place the earring into the hole in the fixture. Then tighten the brass knob, which will close the brass jaws and secure the earring. Now you are ready to set your earring.

Order #	Description	1+
53-0601	Earring Setting Tool	\$38.00

### SPECIAL FEATURES

Insert Post for Earring



Brass Claws for Securing Earring Basket



Knob to Tighten the Claws

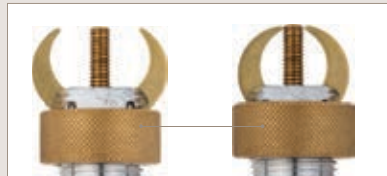

Mounting Height Adjustment Knob



Cone Collet Mounts

Set Screw

Ring Jig

Rectangle Fixture

Octagon Fixture

Expandable Collets

### RING SETTING TOOL

The Stuller exclusive ring setting tool was created by a master jeweler. The kit comes complete with two fixtures, two sets of nine interchangeable dies, knobs, and allen wrenches for tightening the collets. Using this tool is very easy. First, choose the correct collet size to fit inside the ring. Next, place the ring over the collet and then secure the ring by using the provided allen wrench or knob. Place the fixture into your mini or standard engraving ball, and you are ready to channel set, bead set, or engrave. The angled fixture allows you to change the angle of your working surface for easier setting or engraving. The straight edged fixture allows you to mount your rings with the lap area of the ring exposed to aid in the process of engraving and setting stones on side of the shank.

Order #	Description	1+
53-0603	Ring Setting Tool	\$96.90



Find added video content on [Stuller.com/VideoCenter](http://Stuller.com/VideoCenter).

### GRS®BENCHMATE® ACCESSORIES

Fixed Mounting Plate: Used for mounting BenchMate and other GRS products to your bench.

### ENCORE QCX: BASIC PACKAGE

The redefined form of the BenchMate Encore QCX delivers the widest range of motion available from any hands-free workholding tool. The BenchMate Encore QCX is easy to keep centered under the microscope and can be adjusted without losing sight of the workpiece. Two threaded collar rings make height changes to the mandrel fast and easy. The handrest can be quickly attached to either side.

### ENCORE QC: BASIC PACKAGE

Work is held steadily in place yet easily repositionable to accommodate a range of techniques and jobs. The new BenchMate Encore QC arm measures 6" and has a cutout for superior access angles and better clearance when using tools. Adjust the relieved arm to a lower or higher vertical position for maximum comfort and control. The handrest can be quickly attached to either side.

### ENCORE QC: STONE SETTER'S PACKAGE

Work is held steadily in place yet easily repositionable to accommodate a range of techniques and jobs. The new BenchMate Encore QC arm measures 6" and has a cutout for superior access angles and better clearance when using tools. Adjust the relieved arm to a lower or higher vertical position for maximum comfort and control. The handrest can be quickly attached to either side.

### ENCORE QCX: STONE SETTER'S PACKAGE

The redefined form of the BenchMate Encore QCX delivers the widest range of motion available from any hands-free workholding tool. The BenchMate Encore QCX is easy to keep centered under the microscope and can be adjusted without losing sight of the workpiece. Two threaded collar rings make height changes to the mandrel fast and easy. The handrest can be quickly attached to either side.

Item	Order #	Description	12+	6+	1+
A	26-4099	Encore QCX: Basic Package	\$297.50	\$315.00	\$350.00
B	26-4100	Encore QC: Basic Package	\$262.65	\$278.10	\$309.00
C	26-4101	Encore QC: Stone Setter's Package	\$395.25	\$418.50	\$465.00
D	26-4102	Encore QCX: Stone Setter's Package	\$433.50	\$459.00	\$510.00
REPLACEMENT PARTS					
E	26-4103	Knob Assembly	\$4.85	\$5.13	\$5.70
F	26-4107	Fixed Mounting Plate	\$16.83	\$17.82	\$19.80
G	26-4120	Jaw Inserts	\$6.97	\$7.38	\$8.20
H	26-4125	Inside Ring Holder with 7 Collets	\$74.80	\$79.20	\$88.00
J	26-4126	Replacement Thumb Screw	\$1.28	\$1.35	\$1.50
K	26-4148	Replacement 7 Collet Set	\$40.76	\$43.16	\$47.95
L	26-4158	Sawing Plate Right-Handed	\$30.01	\$31.77	\$35.30
M	26-4159	Sawing Plate Left-Handed	\$31.37	\$33.21	\$36.90







Find added video content on [Stuller.com/VideoCenter](http://Stuller.com/VideoCenter).

**GRS® ID RING HOLDER**

Take ring fixtures to a new level. The expansion cones assure equal pressure on both sides of the mandrel as it grips the inside diameter of the ring. When using the standard cone, the ring drag can be set to allow smooth rotation of the piece, while setting stones or engraving the ring surface. Includes a set of 10 mandrels and all tooling.

Order #	Description	12+	6+	1+
26-4182	Ring Holder	\$65.45	\$69.30	\$77.00



**RING SETTERS INSIDE CLAMP**

This unique tool allows you to access the entire circumference of your ring. Includes nine plastic sleeve inserts marked clearly in U.S. sizes from 2-13 and in millimeter sizes 13-22. Firmly grips ring from the inside without marking, which allows you to work on the outside of the ring. Smooth hardwood handle for comfortable hand-held operations. Packaged in a hardwood box.

Order #	Description	12+	6+	1+
48-1350	Inside Ring Clamp Set	\$27.71	\$29.34	\$32.60



**MULTI-ANGLE RING SETTER'S CLAMP**

This ring setter's clamp set features three head configurations to help you hold rings securely while setting stones in vertical, horizontal, or angled positions. This set includes a handle (5 3/4" L) with 10 nylon split-collet inserts that will accommodate U.S. ring sizes 2 to 14.

Order #	Description	12+	6+	1+
48-1351	Multi-angle Clamp Set	\$50.96	\$53.96	\$59.95



**GRS® BENCH PIN KIT**

Wooden bench pin with holder for use with GRS® mounting plates.

Item	Order #	Description	12+	6+	1+
A	26-4114	Bench Pin Kit	\$27.12	\$28.71	\$31.90
	26-4114	Replacement Pin	\$4.63	\$4.91	\$5.45



**BENCH PIN IN METAL HOLDER**

Screws easily to the edge of the workbench. Thumbscrew locks bench pin securely in place. Measures four inches.

Order #	Description	12+	6+	1+
13-3200	Bench Vise	\$7.61	\$8.06	\$8.95

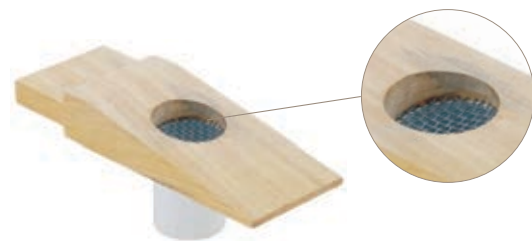

**BENCH SUCTION PIN**

This unique bench pin allows you to cut, grind, and polish without debris flying through the air. Attach your two-inch hose from your Quatro basic or Quatro gold vault to the flange located on the bottom of the bench pin, and watch the debris go down the hose and into your dust collector.

Order #	Description	12+	6+	1+
47-4122	Suction Pin	\$33.15	\$35.10	\$39.00

**WOOD BENCH PINS**

Fits into slot in workbench. Use as support when filing, sawing, and setting.

Item	Order #	WxLxH	12+	6+	1+
A	13-3000	2 1/8"x5"x1/4"	\$2.55	\$2.70	\$3.00
B	13-3001	2 1/2"x6 1/2"x1/4"	\$2.76	\$2.93	\$3.25
C	13-3002	3"x7"x1/4"	\$3.53	\$3.74	\$4.15

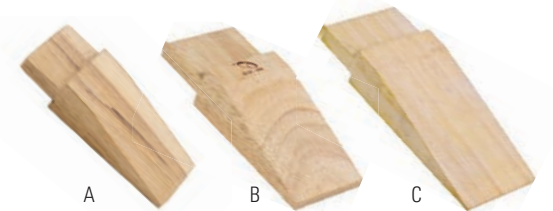

**COMBINATION BENCH PIN AND ANVIL**

Use to support pieces being flattened and for layout work. Combination polished steel anvil and wood bench pin measures 1 3/4" and 4". Flat anvil is smoothly finished. Adjustable clamp allows use on benches up to two inches thick.

Item	Order #	Description	WxLxH	12+	6+	1+
D	13-3205	Combo Bench Pin and Anvil	1 3/4"x4"x2"	\$14.03	\$14.85	\$16.50
E	13-3207	Extra Bench Pins	1 3/4"x4"x2"	\$2.34	\$2.48	\$2.75



**THE PEG ASSIST**

The Peg Assist™ by Jay Whaley is a premium ring clamp with improved features. Offers a non-slip, extra-long round peg. Ideal shape for a secure hold with quality leather-lined jaws. Clamp length: 6"; Peg length: 4 3/4". Patent pending.

Order #	Description	12+	6+	1+
48-4000	Peg Assist Ring Clamp	\$11.01	\$11.66	\$12.95



**BENCH PIN FOR RINGS**

Shaped specifically to hold rings. Also has a slot and a channel for saw blade. Easily attaches to the top of bench.

Order #	WxLxH	12+	6+	1+
13-3030	1/2"x5 1/2"x3/8"	\$3.83	\$4.05	\$4.50



**BENCH CLAMPS**

Ring clamps are standard fare for the bench jeweler. Stuller is proud to offer a great selection of quality ring clamps to meet the needs of our valued customers.

Item	Order #	Description	Length	12+	6+	1+
F	48-1010	Plastic (Nylon) Double Leather Lined	7"	7.61	8.06	8.95
G	48-1020	Mahogany Double Leather Lined	7 1/2"	6.80	7.20	8.00
H	48-1032	Euro-Style Ring Clamp	5 3/4"	7.61	8.06	8.95
J	48-1034	Wood Ring Vise	6"	5.53	5.85	6.50
K	48-1035	Wood Inside Ring Vise		5.91	6.26	6.95
L	48-1067	Wood Grooved Slot Holder 8" Length	7 3/4"	5.19	5.49	6.10
M	48-1000	Hardwood Double Leather Lined	7"	5.61	5.94	6.60







**CASE ANODIZED ALUMINUM RING CLAMP**

This Swiss ring clamp is made of case anodized aluminum and operates at its base by a screw knob. The knob gives added force to the parallel clamping. It also makes a sure grip.

Order #	Description	12+	6+	1+
48-1065	Case Anodized Aluminum Ring Clamp	\$25.29	\$26.78	\$29.75



**DELUXE PRONG LIFTER**

Precision tool made of steel with a Rockwell hardness of 57-59. Features extra-sharp, long-lasting edges.

Order #	WxL	12+	6+	1+
53-1442	1/4"x3 3/4"	\$12.58	\$13.32	\$14.80



**KIRKLAND RING CLAMP HOLDER**

Use for polishing the inside and outside of rings. One end clamps from the outside for polishing and stone setting. The other end holds the ring from the inside for total circumference polishing and buffing. Heat is conducted away from the ring due to the metal construction. Accommodates ring sizes 1-13.

Order #	Length	12+	6+	1+
48-1050	5 1/2"	\$15.26	\$16.16	\$17.95



**KIRKLAND EXTERNAL RING CLAMP**

Made of cast aluminum, this clamp holds a ring externally, which allows the inside to be filed, ground, or polished. Jaws are slightly concave and lined with thick leather, so they will not scratch gold, silver, or other precious metals.

Order #	Length	12+	6+	1+
48-1060	6"	\$22.10	\$23.40	\$26.00



**PRONG PUSHER**

Use for pushing prongs or crown points around stones. Made of steel and mounted in wood handle.

Order #	Length	12+	6+	1+
53-1406	3 1/2"	\$2.81	\$2.97	\$3.30



**BEZEL PUSHER**

Use for pushing and rolling bezels around stones. Grooved steel mounted in wood handle.

Order #	Length	12+	6+	1+
53-1400	3 3/4"	\$8.46	\$8.96	\$9.95



**BEZEL ROLLER**

Use for rolling bezels around stones in rings, pendants, and brooches. Half-round, highly polished steel head with wood handle.

Order #	Length	12+	6+	1+
53-1402	4"	\$2.81	\$2.97	\$3.30

**BENCH KNIFE**

Heavy-duty, bench knife features a thick steel blade and heavy hardwood handle.

Order #	Length	Blade Length	12+	6+	1+
39-0626	5 1/2"	1 5/8"	\$3.74	\$3.96	\$4.40



**MEDIUM-DUTY BENCH KNIFE**

Use for opening watch cases, scraping, and cutting. Blade is mounted in hardwood handle.

Order #	Length	Blade Length	12+	6+	1+
39-1800	5"	1 3/4"	\$8.42	\$8.91	\$9.90



**TUNGSTEN-CARBIDE SCRAPERS**

Flat-sided, tungsten-carbide scrapers are ideal for flash and bur removal on precious metals. Recommended for platinum.

Item	Order #	Length	Tip Length	Tip Diameter	12+	6+	1+
A	18-0520	6 1/4"	1 1/4"	3mm	\$17.21	\$18.23	\$20.25
B	18-0521	6 1/4"	1 1/4"	4mm	\$17.21	\$18.23	\$20.25



**CURVED BLADE**

Highly polished blades mounted in wooden handles are used for smoothing bezels around stones as well as other parts of soft metals.

Item	Order #	Description	Length	Tip Length	12+	6+	1+
C	18-0500	Curved Blade	5 3/4"	1"	\$10.84	\$11.48	\$12.75
D	18-0502	Straight Blade	5 1/2"	1"	\$8.46	\$8.96	\$9.95
E	18-0510	Curved Blade	6"	2"	\$8.46	\$8.96	\$9.95



**TUNGSTEN-CARBIDE BURNISHERS**

Highly polished and very hard burnishers made of tungsten carbide are used for closing bezels, smoothing away scratches, and burnishing metals to a brilliant shine. Recommended for platinum work.

Item	Order #	Length	Tip Length	Tip Diameter	12+	6+	1+
F	18-0516	6 3/4"	1"	2mm	\$14.88	\$15.75	\$17.50
G	18-0517	6 3/4"	1"	3mm	\$14.88	\$15.75	\$17.50
H	18-0518	6 3/4"	1"	4mm	\$14.88	\$15.75	\$17.50
J	18-0519	6 3/4"	1"	5mm	\$14.24	\$15.08	\$16.75

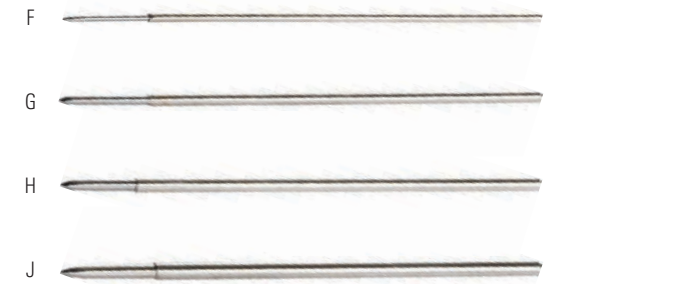

**STRAIGHT BLADE**

Slim steel burnishers with hardwood handles are perfect for smaller jobs. Highly polished steel assures the user a smooth finish every time. Hardwood handle is the right grip for this well made burnisher. Blade options include straight and bent.

Item	Order #	Description	Length	Tip Length	12+	6+	1+
K	18-0525	Straight Blade	6"	2 1/4"	\$5.27	\$5.58	\$6.20
L	18-0526	Bent Blade	6 1/2"	2 1/2"	\$6.55	\$6.93	\$7.70



Bench Tools

Bench Tools



**TUNGSTEN-CARBIDE ROLLER BURNISHERS**

High-quality, tungsten-carbide roller burnishers are ideal for removing small or coarse pinholes and scratches on platinum or gold.

Item	Order #	OD	Length	Edges	Grade	Application	12+	6+	1+
A	18-0535	5mm	13mm	12	Coarse	Gold	\$30.41	\$31.73	\$33.05
B	18-0537	5mm	13mm	36	Fine	Platinum	\$30.82	\$32.16	\$33.50
C	18-0538	10mm	7mm	18	Medium	Gold/Platinum	\$30.82	\$32.16	\$33.50
D	18-0539	10mm	7mm	36	Fine	Gold/Platinum	\$30.82	\$32.16	\$33.50



**MARGIN ROLLER BURNISHERS**

Individually sized burnishing tools effectively remove porosity, pits, and scratches on the inside of rings and bracelets.

Item	Order #	Diameter	Shank	12+	6+	1+
E	18-0530	5mm	3/32"	\$15.15	\$16.43	\$18.25
F	18-0531	8mm	3/32"	\$32.20	\$33.60	\$35.00
G	18-0532	10mm	3/32"	\$34.34	\$36.36	\$40.40



**POROSITY KILLER**

Fills minor porosity holes in gold, silver, platinum, and other metals. Eliminates the need for extra filing and filling holes with solder.

Order #	Wheel Size	Shank	12+	6+	1+
18-0545	1/2" square	3/32"	\$12.11	\$12.83	\$14.25



**BUSCH® TUNGSTEN-CARBIDE POLISHERS**

Produce a brilliant polish on platinum and gold with the Busch tungsten-carbide polishers. These polishers are made of the finest tungsten-carbide material, which makes them ideal for platinum polishing. The four different shapes highlight surfaces, edges, elevated areas, and recessed or relatively inaccessible spots.

Item	Order #	Description	Shank	12+	6+	1+
H	18-0540	Round End Pointer	3/32"	\$43.19	\$45.07	\$46.95
J	18-0541	Barrel Polisher	3/32"	\$46.93	\$48.97	\$51.01
K	18-0542	Cone Polisher	3/32"	\$43.19	\$45.07	\$46.95
L	18-0543	Point Polisher	3/32"	\$43.19	\$45.07	\$46.95

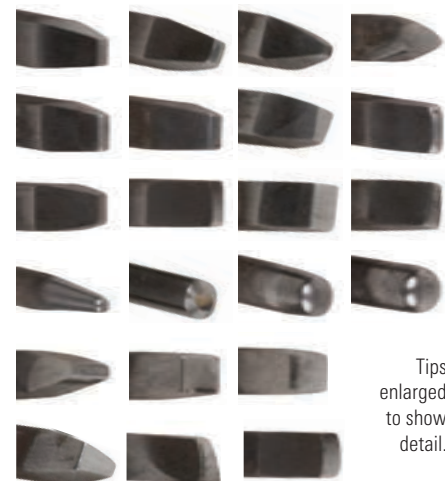

Tips enlarged to show detail.

**22 CHASING TOOLS**

Set of 22 punches with differently shaped ends for making decorative designs on sheet metal. The ends of the tools are struck with a chasing hammer while the work is held in a pitch bowl.



Order #	Description	Length	12+	6+	1+
25-1347	22 Punches	3 7/8" - 3 1/16"	\$106.04	\$112.28	\$124.75



**SWISS BEADING KIT SET**

Deluxe Swiss-made beading tool set consists of

- 100 beading tools
- Five each no. 5-6-7-8
- 15 each no. 9-10-11-12
- Five each no. 13-14-15-16
- Beading plate, beading tool handle, and 40-hole deluxe wood holder



Order #	Description	12+	6+	1+
53-1725	Swiss Beading Kit	\$136.00	\$144.00	\$160.00

**BEAD BLOCK**

In order to sharpen and reshape the tips of your beading tools, apply slight pressure to the beading tool and rotate the tip within the round shape hole. Re-insert the tip and repeat the process until shape is uniform.



Order #	Description	12+	6+	1+
53-1726	Sharpening Block	\$25.50	\$27.00	\$30.00

**1.35MM - #22**

Genuine Swiss beading tool sets and individual sizes. 3/32" shank. Used mostly in beading or bright-cut settings. Can also be used to make beaded edge designs. Smallest (.25mm) to largest (1.35mm)

**Kit Order # 77-29000**

Item	Description	Size	12+	6+	1+
A	Set of 12 (1 each)	.25mm-1.35mm	\$17.43	\$18.90	\$21.00
	Set of 23 (1 each)	.25mm-1.35mm	\$22.44	\$23.76	\$26.40

Item	Order #	Description	12+	6+	1+
B	77-2940	Beading Tool Handle	\$2.56	\$2.88	\$3.20

**Order # 77-29000**

- Shank Size 3/32"
- Sold Each

mm	.25	.30	.35	.40	.45	.50	.55	.60	.65	.70	.75	.80
Tool #	#0	#1	#2	#3	#4	#5	#6	#7	#8	#9	#10	#11
12+	\$1.16	\$1.16	\$1.16	\$1.16	\$1.16	\$1.16	\$1.16	\$1.16	\$1.16	\$1.16	\$1.16	\$1.16
6+	\$1.32	\$1.32	\$1.32	\$1.32	\$1.32	\$1.32	\$1.32	\$1.32	\$1.32	\$1.32	\$1.32	\$1.32
1+	\$1.65	\$1.65	\$1.65	\$1.65	\$1.65	\$1.65	\$1.65	\$1.65	\$1.65	\$1.65	\$1.65	\$1.65

mm	.85	.90	.95	1.00	1.05	1.10	1.15	1.20	1.25	1.30	1.35
Tool #	#12	#13	#14	#15	#16	#17	#18	#19	#20	#21	#22
12+	\$1.16	\$1.16	\$1.16	\$1.16	\$1.16	\$1.16	\$1.16	\$1.16	\$1.16	\$1.16	\$1.16
6+	\$1.32	\$1.32	\$1.32	\$1.32	\$1.32	\$1.32	\$1.32	\$1.32	\$1.32	\$1.32	\$1.32
1+	\$1.65	\$1.65	\$1.65	\$1.65	\$1.65	\$1.65	\$1.65	\$1.65	\$1.65	\$1.65	\$1.65

**PRIMO SNAP OFF BEADING TOOL**

**Order # 18-5180**

- PRIMO Beading Tool
- Sold Each
- Pack of 10 - \$10.00

mm	.25	.30	.35	.40	.45	.50	.55	.60	.65	.70	.75	.80
Tool #	#0	#1	#2	#3	#4	#5	#6	#7	#8	#9	#10	#11
12+	\$1.15	\$1.15	\$1.15	\$1.15	\$1.15	\$1.15	\$1.15	\$1.15	\$1.15	\$1.15	\$1.15	\$1.15
6+	\$1.20	\$1.20	\$1.20	\$1.20	\$1.20	\$1.20	\$1.20	\$1.20	\$1.20	\$1.20	\$1.20	\$1.20
1+	\$1.25	\$1.25	\$1.25	\$1.25	\$1.25	\$1.25	\$1.25	\$1.25	\$1.25	\$1.25	\$1.25	\$1.25

mm	.85	.90	.95	1.00	1.05	1.10	1.15	1.20	1.25	1.30	1.35
Tool #	#12	#13	#14	#15	#16	#17	#18	#19	#20	#21	#22
12+	\$1.15	\$1.15	\$1.15	\$1.15	\$1.15	\$1.15	\$1.15	\$1.15	\$1.15	\$1.15	\$1.15
6+	\$1.20	\$1.20	\$1.20	\$1.20	\$1.20	\$1.20	\$1.20	\$1.20	\$1.20	\$1.20	\$1.20
1+	\$1.25	\$1.25	\$1.25	\$1.25	\$1.25	\$1.25	\$1.25	\$1.25	\$1.25	\$1.25	\$1.25







STANDARD 1/8" SHANK

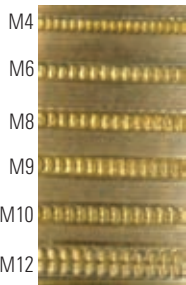
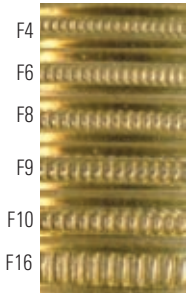

**MILLRITE MILGRAIN MACHINE**

The Milgrain is an innovative machine that allows you to create professional decorative designs on rings without the need of a lathe. The designs are cold formed in the surface of the ring without the loss of any precious metal. A variety of tools are available to provide clean, well-defined designs according to the chosen styles. The machine comes complete with 10 collets for ring sizes from #2-13, one milgrain tool, and an allen key.

Item	Order #	Description	12+	6+	1+
A	26-6000	Milgrain Machine	—	—	\$550.00
B	26-6001	Set of 10 Collets	\$12.79	\$13.55	\$15.05

STANDARD EMBOSSING WHEELS (6mm diameter, 1/8" shank)

Order # 26-6002		Description	12+	6+	1+
		F4 Raised Bead Pattern	\$61.00	\$63.65	\$66.30
		F6 Raised Bead Pattern	\$61.00	\$63.65	\$66.30
		F8 Raised Bead Pattern	\$61.00	\$63.65	\$66.30
		F9 Raised Bead Pattern	\$61.00	\$63.65	\$66.30
		F10 Raised Bead Pattern	\$61.00	\$63.65	\$66.30
		M4 Indented Bead Pattern	\$61.00	\$63.65	\$66.30
		M6 Indented Bead Pattern	\$61.00	\$63.65	\$66.30
		M8 Indented Bead Pattern	\$61.00	\$63.65	\$66.30
		M9 Indented Bead Pattern	\$61.00	\$63.65	\$66.30
		M10 Indented Bead Pattern	\$61.00	\$63.65	\$66.30

**MILLRITE PLUS MILGRAIN MACHINE**

The Millrite Plus Milgrain Machine allows you to create designs on your rings, even on angled or perpendicular surfaces. This machine accepts both lathe milgrain tools and french milgrain tools. It also includes collets for ring sizes 2-14. The machine is quality crafted of aluminum alloy with spring action tool holders that ensure clean, crisp, even empressions.

Item	Order #	Description	1+
C	26-6003	Milgrain Plus Machine	\$640.00

**MILGRAIN TOOLS**

Cup-shaped cutters used to form a decorative bead or fine row of cuts on any piece of jewelry. Set of six contains sizes 2, 4, 6, 8, 10, 12, and a chuck holding handle. Smallest (#1) to Largest (#15).

Order # 53-00000

- 3" Length
- Cup-shaped Cutters

Kit Order # 53-1000

	D. Round Set #1 - #15	E. Oval Set #1 - #15
12+	\$55.20	\$55.20
6+	\$57.60	\$57.60
1+	\$60.00	\$60.00



Shape	Round	Round	Round	Round	Round	Round	Round	Round	Round	Round
Tool #	#1	#2	#3	#4	#5	#6	#7	#8	#9	#10
12+	\$9.89	\$9.89	\$9.89	\$9.89	\$9.89	\$9.89	\$9.89	\$9.89	\$9.89	\$9.89
6+	\$10.32	\$10.32	\$10.32	\$10.32	\$10.32	\$10.32	\$10.32	\$10.32	\$10.32	\$10.32
1+	\$10.75	\$10.75	\$10.75	\$10.75	\$10.75	\$10.75	\$10.75	\$10.75	\$10.75	\$10.75

Shape	Round	Round	Round	Round	Round	Oval	Oval	Oval	Oval	Oval
Tool #	#11	#12	#13	#14	#15	#1	#2	#3	#4	#5
12+	\$9.89	\$9.89	\$9.89	\$9.89	\$9.89	\$9.89	\$9.89	\$9.89	\$9.89	\$9.89
6+	\$10.32	\$10.32	\$10.32	\$10.32	\$10.32	\$10.32	\$10.32	\$10.32	\$10.32	\$10.32
1+	\$10.75	\$10.75	\$10.75	\$10.75	\$10.75	\$10.75	\$10.75	\$10.75	\$10.75	\$10.75

Shape	Oval	Oval	Oval	Oval	Oval	Oval	Oval	Oval	Oval	Oval
Tool #	#6	#7	#8	#9	#10	#11	#12	#13	#14	#15
12+	\$9.89	\$9.89	\$9.89	\$9.89	\$9.89	\$9.89	\$9.89	\$9.89	\$9.89	\$9.89
6+	\$10.32	\$10.32	\$10.32	\$10.32	\$10.32	\$10.32	\$10.32	\$10.32	\$10.32	\$10.32
1+	\$10.75	\$10.75	\$10.75	\$10.75	\$10.75	\$10.75	\$10.75	\$10.75	\$10.75	\$10.75

Handle only - Item # 37-7640



**PITCH BOWL SET**

Suitable for holding or supporting jewelry for engraving. The bowl is made of cast iron and rests on a rubber pad. The bowl can be tipped to a comfortable working angle. Includes pitch, bowl, and rubber pad.

Order #	Description	Outside Diameter	1+
26-4205	Pitch Bowl Set	6 1/4"	\$39.75



**STARTER KIT**

Kit includes six-inch square PTFE (Teflon) pad and one pound Thermo-Loc® sticks. Thermo-Loc® is a special reusable polymer material that is rigid at room temperature yet becomes softly pliable when heated/warmed. Always place on Thermo-Loc® (Teflon) pad when warming in microwave oven. Ring not included.

Item	Order #	Description	12+	6+	1+
A	26-4168	Starter Kit	\$41.86	\$43.68	\$45.50
B	26-4169	1 lb of Sticks	\$38.32	\$39.98	\$41.65

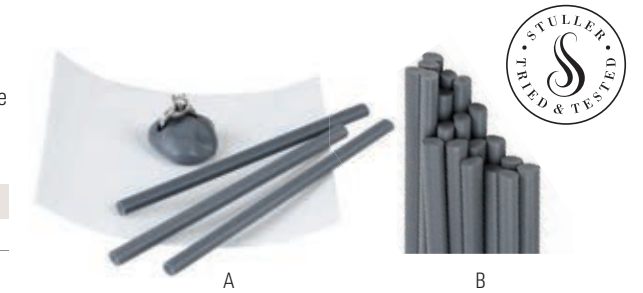

**ORANGE FLAKE SHELLAC**

When heated, this shellac is used to hold objects for chasing, engraving, or setting.

Order #	Description	Container Volume	12+	6+	1+
12-2270	Flake Shellac	6 oz	\$12.47	\$13.01	\$13.55



**JIG KIT**

This tool makes claw settings in sizes 0.15 to 2 carats with four, six, and eight prongs for small or large rings. The set comes with five wire holders, four retaining tubes, one main base, and instructions.

Order #	Description	12+	6+	1+
53-1425	Jig Kit	\$28.09	\$29.75	\$33.05



**SETTERS TUBE HOLDER KIT**

Holds tubes for stone setting firmly without damage. Set of seven spring-tempered three-jaw collets. Screw chuck has hardwood handle. Collets fit tube sizes 1/32" to 1/2". Shipping weight .20 lb.

Order #	Description	Length	12+	6+	1+
26-6006	Pin Vise Kit	6"	\$18.62	\$19.71	\$21.90



**SET OF 18 PUNCHES**

These bezel punches with concave ends shape bezels over round stones. Set comes with hardwood handle and wooden box.

Item	Order #	Assortment Qty	Size Range	12+	6+	1+
C	53-1409	1.0 mm - 7.9 mm	24	\$135.32	\$143.28	\$159.20
D	53-1412	1.0 mm - 7.9 mm	24	\$132.22	\$140.00	\$155.55





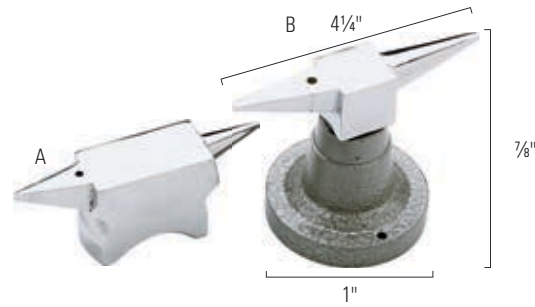

**HORN ANVILS**

Use for flattening and shaping, these anvils feature polished flat and round horns. There is a hole in the top for riveting. Made of drop-forged steel, they are case hardened.

Item	Order #	Description	W×L×H	12+	6+	1+
A	12-3050	Horn Anvil	1 1/8"×4 1/2"×1 5/8"	\$22.48	\$23.81	\$26.45
B	12-3010	Double Horn Anvil	1"×4 1/4"×7/8"	\$15.90	\$16.83	\$18.70

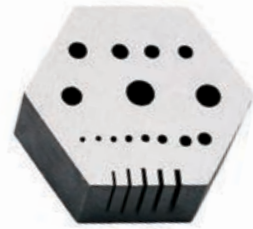

**HEXAGON ANVIL**

Use as a base for staking, riveting, and drilling small parts. Case-hardened and ground flat and smooth, it has 15 holes, graduated from 3/64" to 1/4" and five milled slots.

Order #	Description	W×H	12+	6+	1+
12-3117	Hexagon Anvil	1 5/8"×3/4"	\$15.90	\$16.83	\$18.70

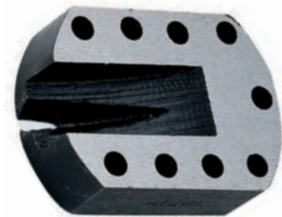

**SLOT ANVIL**

Use as a base for staking, riveting, and drilling small parts. V-Slot is handy for removing pinions and similar items. Case hardened and ground flat and smooth, it has nine graduated holes with one size for stumps and five milled slots.

Order #	Description	W×L×H	12+	6+	1+
12-3115	Slot Anvil	1 5/8"×1 3/4"×3/4"	\$12.75	\$13.50	\$15.00

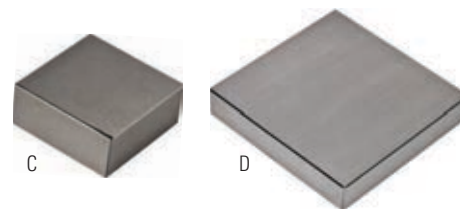

**STEEL BENCH BLOCK**

Use to support work when flattening or laying out designs. Case-hardened. Ground flat and smooth.

Item	Order #	W×L×H	12+	6+	1+
C	12-3107	2 1/2"×2 1/2"×3/4"	\$15.30	\$16.20	\$18.00
D	12-3109	4"×4"×3/4"	\$17.85	\$18.90	\$21.00



**BENCH BLOCK HELPER**

This three-piece set allows one to hammer without excess noise and vibrations at the bench. Includes rubber ball with steel and nylon block.

Order #	Diameter	Thickness	Per Pack	12+	6+	1+
25-0572	3"	1 5/16"	Box of 25	\$27.16	\$28.76	\$31.95

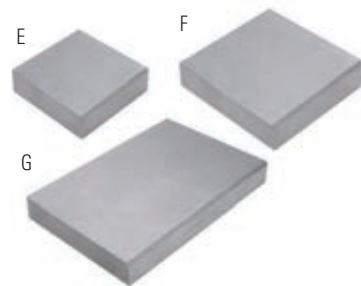

**DURSTON BENCH BLOCKS**

Durston's new high-quality steel bench blocks for flattening, laying out, or chasing. Each piece is constructed out of tool steel, ground flat, polished, and case hardened.

Item	Order #	W×L×H	12+	6+	1+
E	12-3110	65mm×65mm×20mm	\$20.61	\$21.83	\$24.25
F	12-3110	100mm×100mm×20mm	\$27.20	\$28.80	\$32.00
G	12-3110	130mm×130mm×20mm	\$35.70	\$37.80	\$42.00

**BEADALON® LEATHER PAD FOR BENCH BLOCK/ANVIL**

Beadalon 4"x4" Leather Pad for Bench Block/Anvil

Order #	Description	W×L	12+	6+	1+
12-3020	Beadalon® Leather Pad	4"×4"	\$8.42	\$8.91	\$9.90



**FOREDOM® DRILL VISE**

Plastic mini vise is great for holding gemstones and other materials that require water during the drilling process.

Order #	Description	Jaw: L×H×Capacity	12+	6+	1+
58-2434	Drill Vise	1 5/8"×1 3/16"×1 1/2"	\$16.83	\$17.82	\$19.80



**METAL VISE**

Zinc, die-cast, mini vise firmly grasps small work pieces for precision drilling. Has horizontal and vertical V grooves for holding small round pieces. Use with DP30, item 34-6302.

Order #	Description	Jaw: L×H×Capacity	12+	6+	1+
34-6301	Metal Vise	1 1/4"×1 1/2"×1/2"	\$21.46	\$22.73	\$25.25



**BERGEON VISE WITH DETACHABLE VISE**

Screw the attaching plate to the workbench to have a vise that can be set up or removed in a few seconds. Utilizes a reliable clamping device with its operating lever on the side by the vise. Absolutely smooth, parallel 45mm jaws. Fits optional mounting plate installed on bench top.

Order #	Description	Jaw Size	12+	6+	1+
58-2436	Precision Bench Vise	45mm	\$328.02	\$347.31	\$385.90



**BENCH VISE**

Sturdy construction with twin guide rods to assure parallel closing and rigidity. Smooth jaws prevent marring of soft metals. Rust-proof finish. Clamps to any bench. Jaws are 2 1/2" wide and open to 2 1/2". Will mount on surfaces up to two inches thick.

Order #	Description	Jaw Size	12+	6+	1+
58-2432	Bench Vise	2 1/2"	\$44.92	\$47.57	\$52.85



**BENCH VISE**

Bench vise with twin guides to assure parallel closing and rigidity. Smooth jaws prevent marring of soft metals. Jaws are 1 3/4" wide and open to 1 3/4". Will mount on surfaces up to two inches thick.

Order #	Description	Jaw Size	12+	6+	1+
58-2430	Bench Vise	1 3/4"	\$14.03	\$14.85	\$16.50







**SWIVEL VISE**

Portable universal ball joint rotates vise to any desired working angle. Attaches instantly to any smooth surface. Large v-grooved iron jaws open to three inches with precise screw action. Unit also comes with a set of rubber jaws.

Order #	Description	12+	6+	1+
58-1030	Swivel Vise	\$48.62	\$51.48	\$57.20



**PANA VISE COMBO**

The original PanaVise is known around the world as a work holding tool for hobbies, electronics, small home repairs, and work bench environments. Easy-to-use single knob controls head movement through three planes: 90° tilt, 360° turn, and 360° rotation. Interchangeable jaws available.

Order #	Description	1+
58-2422	PanaVise Combo	\$53.00



**VACUUM-BASE PANAVISE**

Quickly attaches to any smooth, non-porous flat surface with the flip of a lever. Take it anywhere.

- Our Vacuum-Base PanaVise is widely used for portable applications.
- Single knob controls head movement through three-planes: 90° tilt, 360° turn and 360° rotation.
- Jaws are 2½" (63.5mm) wide, ½" (12.6mm) tall, and open 2¼" (57.1mm).
- Nylon jaws offer excellent electrical insulation and gentle holding power [continuous heat tolerance up to 200°F (93°C), intermittent heat to 300°F (149°C)]
- Interchangeable jaws available.
- Pad footprint measures 5½" x 4¼" (130.2mm x 108mm).
- Height 6⅞" (155.6mm), weight 2.8lbs (1.3kg).

Order #	Description	12+	6+	1+
58-2423	Vacuum Base PanaVise	\$63.06	\$66.77	\$74.19

**MULTI-PURPOSE VISE**

Precision steel vise for the BenchMate™ system uses the versatile lift-on, lift-off mounting system. This vise tilts and rotates on two axes to virtually any position. Your work moves to accommodate you rather than you adjusting to your work. Jaws are 2½" wide, 1⅓" tall, and open to 1⅝".

Item	Order #	Description	12+	6+	1+
A	26-4144	Multi-Purpose Vise	\$144.50	\$153.00	\$170.00
B	26-4155	Attachment Set	\$112.20	\$118.80	\$132.00

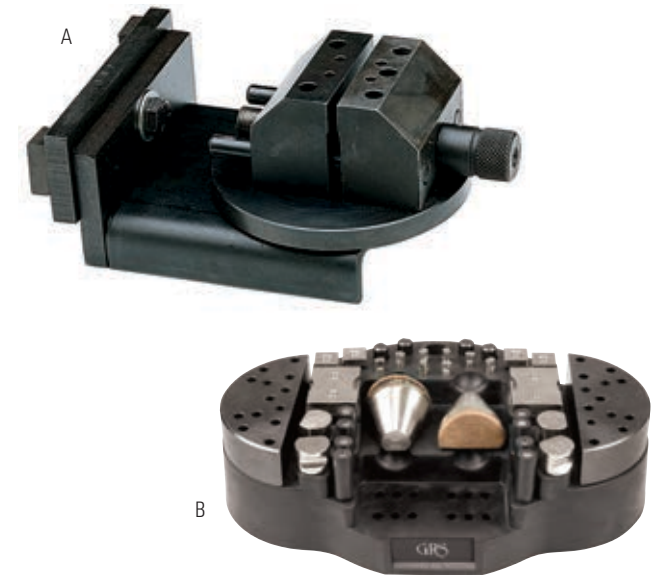

**VISE PADS**

Magnetic strips hold Soft Jaws™ to your bench vise. The cushioned pads grip odd or round shapes and threaded parts preventing marring of finished surfaces. They fit three inches to four inches wide bench vises but can be mounted on larger vises. Do not use to hold glass bottles or beakers.

Order #	Description	Width	12+	6+	1+
58-2438	Vise Pads	3½"	\$7.57	\$8.01	\$8.90

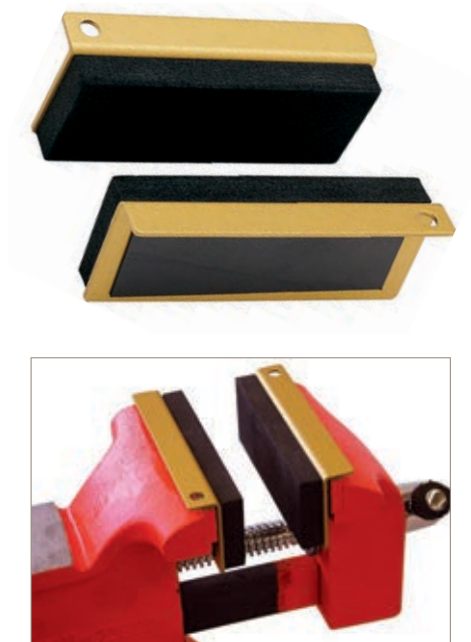

**BRACELET HOLDER**

Use to hold bracelets in place when setting stones in prong, pavé, or channel settings. Saves time and eliminates the need for shellac. Holds bracelets up to seven millimeters wide and will not mar or distort. Space for clasp on outer side of holder. Made of aluminum. 3½" diameter. Includes hex wrench.

Order #	Diameter	Width	12+	6+	1+
43-0600	3½"	¼"	\$27.88	\$29.52	\$32.80



# BRUSHES

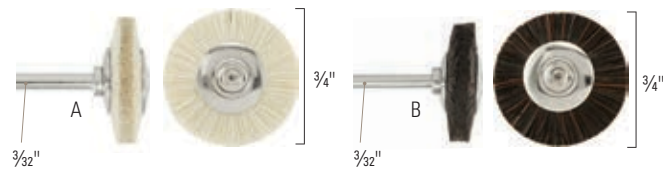

## MOUNTED DOUBLE ROW MINIATURE BRISTLE BRUSHES

Great for cleaning and polishing hard-to-reach areas. For use with flexshafts.

Item	Order #	Grade	Rows	OD	Shank	12+	6+	1+
A	16-6070	Soft	2	3/4"	3/32"	\$22.24	\$25.02	\$27.80
B	16-6072	Hard	2	3/4"	3/32"	\$22.24	\$25.02	\$27.80

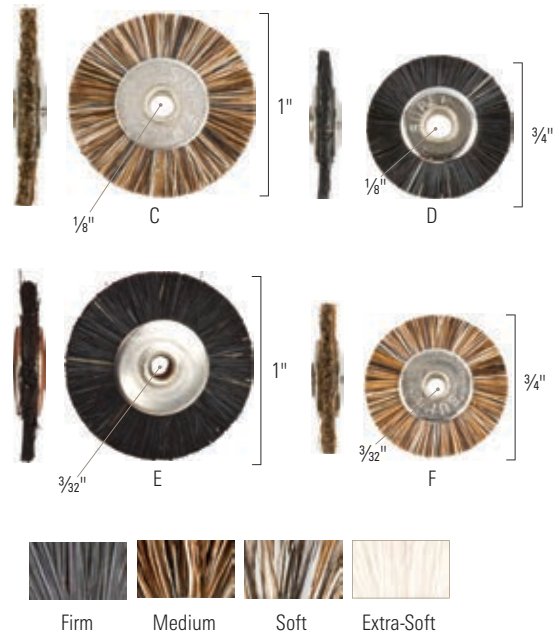

## UNMOUNTED BRISTLE BRUSHES

Stuller Select unmounted bristle brush. 1/8" & 3/32" hole diameters available. Sold in packs of 12.

Item	Grade	OD	Shank	12+	6+	1+
C	Firm	1"	1/8"	\$6.44	\$6.72	\$7.00
	Medium	1"	1/8"	\$6.44	\$6.72	\$7.00
	Soft	1"	1/8"	\$6.44	\$6.72	\$7.00
	Extra Soft	1"	1/8"	\$6.44	\$6.72	\$7.00
D	Firm	3/4"	1/8"	\$4.51	\$4.70	\$4.90
	Medium	3/4"	1/8"	\$4.51	\$4.70	\$4.90
	Soft	3/4"	1/8"	\$4.69	\$4.90	\$5.10
	Extra Soft	3/4"	1/8"	\$4.69	\$4.90	\$5.10
E	Firm	1"	3/32"	\$5.70	\$5.95	\$6.20
	Medium	1"	3/32"	\$5.80	\$6.05	\$6.30
	Soft	1"	3/32"	\$6.44	\$6.72	\$7.00
	Extra Soft	1"	3/32"	\$6.44	\$6.72	\$7.00
F	Firm	3/4"	3/32"	\$4.51	\$4.70	\$4.90
	Medium	3/4"	3/32"	\$4.51	\$4.70	\$4.90
	Soft	3/4"	3/32"	\$4.69	\$4.90	\$5.10
	Extra Soft	3/4"	3/32"	\$4.69	\$4.90	\$5.10



## UNMOUNTED BRISTLE BRUSHES

Item	Grade	OD	Shank	12+	6+	1+
A	Stiff	1"	1/8"	\$2.07	\$2.16	\$2.25
	Medium	1"	1/8"	\$2.07	\$2.16	\$2.25
	Soft	1"	1/8"	\$2.07	\$2.16	\$2.25
B	Stiff	3/4"	1/8"	\$2.07	\$2.16	\$2.25
	Medium	3/4"	1/8"	\$2.07	\$2.16	\$2.25
	Soft	3/4"	1/8"	\$2.07	\$2.16	\$2.25
C	Stiff	1"	3/32"	\$2.07	\$2.16	\$2.25
	Medium	1"	3/32"	\$2.07	\$2.16	\$2.25
	Soft	1"	3/32"	\$2.07	\$2.16	\$2.25
D	Stiff	3/4"	3/32"	\$2.07	\$2.16	\$2.25
	Medium	3/4"	3/32"	\$2.07	\$2.16	\$2.25
	Soft	3/4"	3/32"	\$2.07	\$2.16	\$2.25
E	Stiff	3/4"	3/32"	\$2.07	\$2.16	\$2.25
	Medium	3/4"	3/32"	\$2.07	\$2.16	\$2.25
	Extra Soft	3/4"	3/32"	\$2.07	\$2.16	\$2.25

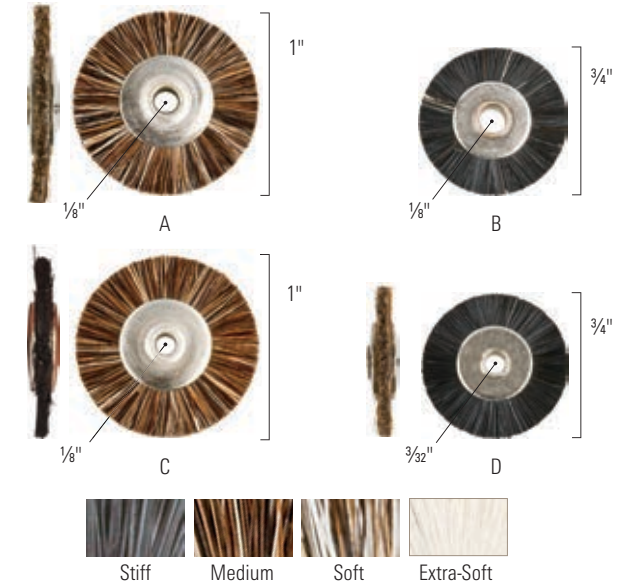

### Suggested Mandrel. Nickel-plated small wheel mandrels.

Order #	Description	Shank	12+	6+	1+
43-1280	Reinforced Screw Mandrel	3/32"	\$0.94	\$0.99	\$1.10



## MOUNTED BRISTLE BRUSHES

Item	Grade	OD	Shank	12+	6+	1+
E	Stiff	1"	3/32"	\$2.07	\$2.16	\$2.25
	Soft	1"	3/32"	\$2.07	\$2.16	\$2.25
	Extra Soft	1"	3/32"	\$2.07	\$2.16	\$2.25
F	Stiff	3/4"	3/32"	\$2.07	\$2.16	\$2.25
	Medium	3/4"	3/32"	\$2.07	\$2.16	\$2.25
	Soft	3/4"	3/32"	\$2.07	\$2.16	\$2.25
G	Stiff	3/4"	3/32"	\$7.72	\$8.69	\$9.65
	Medium	3/4"	3/32"	\$7.72	\$8.69	\$9.65
	Soft	3/4"	3/32"	\$7.72	\$8.69	\$9.65

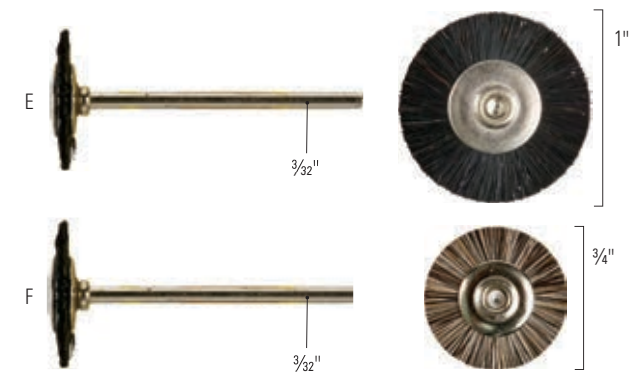

## MOUNTED BRISTLE BRUSHES

Item	Grade	Length	OD	Shank	12+	6+	1+
END	Firm	3/16"	3/8"	3/32"	\$6.68	\$7.25	\$8.05
	Soft	3/16"	3/8"	3/32"	\$6.68	\$7.25	\$8.05
	Firm	3/16"	1/4"	3/32"	\$6.68	\$7.25	\$8.05
	Soft	3/16"	1/4"	3/32"	\$6.68	\$7.25	\$8.05
CUP	Firm	1/2"	9/16"	3/32"	\$3.73	\$3.89	\$4.05
	Soft	1/2"	9/16"	3/32"	\$3.73	\$3.89	\$4.05
	Stiff	1/2"	9/16"	3/32"	\$3.73	\$3.89	\$4.05



## MOUNTED BRISTLE BRUSHES

Item	Grade	Length	OD	Shank	12+	6+	1+
END	Firm	3/16"	3/16"	3/32"	\$1.96	\$2.07	\$2.30
	Soft	3/16"	3/16"	3/32"	\$1.96	\$2.07	\$2.30
	Soft	3/8"	3/16"	3/32"	\$1.96	\$2.07	\$2.30
Firm	3/8"	3/16"	3/32"	\$1.96	\$2.07	\$2.30	

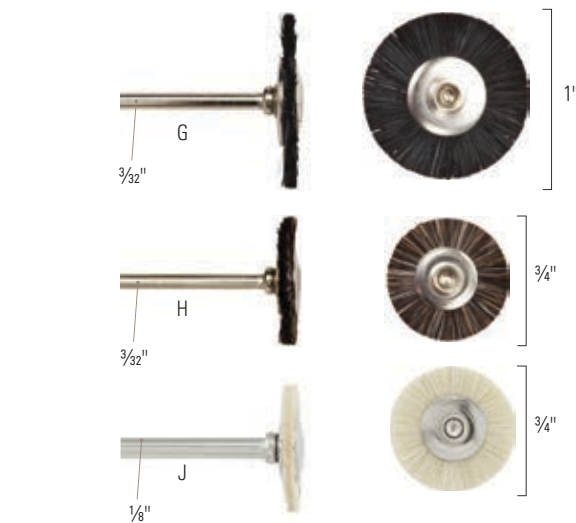

## MOUNTED BRISTLE BRUSHES

Item	Brush Type	OD	Shank	12+	6+	1+
G	Stiff	1"	3/32"	\$3.96	\$4.13	\$4.30
	Medium	1"	3/32"	\$3.96	\$4.13	\$4.30
	Soft	1"	3/32"	\$3.96	\$4.13	\$4.30
H	Stiff	3/4"	3/32"	\$3.96	\$4.13	\$4.30
	Medium	3/4"	3/32"	\$3.96	\$4.13	\$4.30
	Soft	3/4"	3/32"	\$3.96	\$4.13	\$4.30
J	Soft	3/4"	1/8"	\$14.08	\$14.69	\$15.30
	Extra Soft	3/4"	3/32"	\$2.07	\$2.16	\$2.25







**UNMOUNTED BRASS/STEEL WIRE BRUSHES**

Order # 16-25006



Wire Type	OD	Shank	12+	6+	1+
Brass Crimped	3/4"	3/2"	\$7.22	\$7.54	\$7.85
Brass Straight	3/4"	3/2"	\$7.22	\$7.54	\$7.85
Steel Crimped	1"	3/2"	\$8.28	\$8.64	\$9.00
Steel Straight	3/4"	3/2"	\$7.22	\$7.54	\$7.85



**MOUNTED BRASS/STEEL WIRE BRUSHES**

Order # 16-25007



Wire Type	OD	Shank	12+	6+	1+
Brass Crimped	1"	3/2"	\$8.37	\$8.74	\$9.10
Brass Straight	1"	3/2"	\$8.37	\$8.74	\$9.10
Brass Crimped	3/4"	3/2"	\$7.64	\$7.97	\$8.30
Brass Straight	3/4"	3/2"	\$7.64	\$7.97	\$8.30
Steel Crimped	1"	3/2"	\$8.37	\$8.74	\$9.10
Steel Straight	1"	3/2"	\$8.37	\$8.74	\$9.10
Steel Crimped	3/4"	3/2"	\$7.64	\$7.97	\$8.30
Steel Straight	3/4"	3/2"	\$7.64	\$7.97	\$8.30



**MOUNTED STULLER END WIRE BRUSHES**

Order # 16-25008



Wire Type	Length	OD	Shank	12+	6+	1+
Brass Crimped	1/4"	3/16"	3/2"	\$5.80	\$6.05	\$6.30
Brass Straight	1/4"	3/16"	3/2"	\$5.80	\$6.05	\$6.30
Steel Crimped	1/4"	3/16"	3/2"	\$5.80	\$6.05	\$6.30
Steel Straight	1/4"	3/16"	3/2"	\$5.80	\$6.05	\$6.30

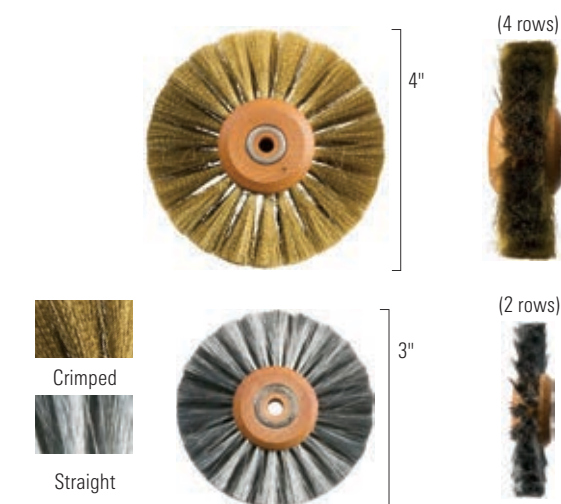

**UNMOUNTED BRASS/STEEL WIRE BRUSHES**

Clean and surface-finish brass and other metals. Straight wire produces a coarser finish.

Order # 16-25009

Wire Type	Rows	OD	12+	6+	1+
Brass Crimped	4	4"	\$11.41	\$11.90	\$12.40
Brass Crimped	2	3"	\$6.95	\$7.25	\$7.55
Steel Crimped	4	4"	\$13.62	\$14.21	\$14.80
Steel Crimped	2	3"	\$8.65	\$9.02	\$9.40

**UNMOUNTED BRASS WIRE BRUSHES**

3" Straight-Brass Wire Brushes produce a coarse finish. Strands are .003." Sold each.

Item	Order #	Bristle Type	Rows	OD	12+	6+	1+
A	16-4262	Straight	2	3"	\$9.20	\$9.60	\$10.00
B	16-4314	Straight	4	3"	\$16.79	\$17.52	\$18.25

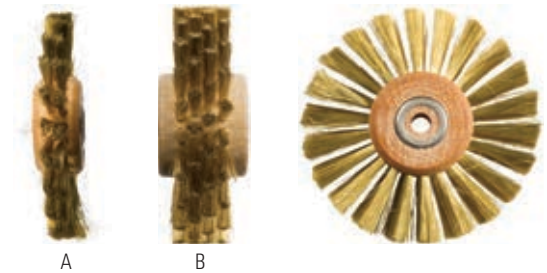

**MOUNTED MINIATURE BRUSHES**

Order # 16-7050



Grade	OD	Shank	Material	12+	6+	1+
Soft	5/8"	3/2"	White Goat Hair	\$10.72	\$11.18	\$11.65
Soft	7/8"	3/2"	White Goat Hair	\$10.72	\$11.18	\$11.65



**MOUNTED MINIATURE BRUSHES**

Geza brush are mounted on an ISO standard stainless steel shank and of high quality chunking and goat hair bristles

Order # 16-7051



Grade	OD	Shank	Material	12+	6+	1+
Soft	7/8"	3/2"	White Goat Hair	\$11.82	\$12.34	\$12.85
Hard	7/8"	3/2"	Gray Goat Hair	\$11.82	\$12.34	\$12.85

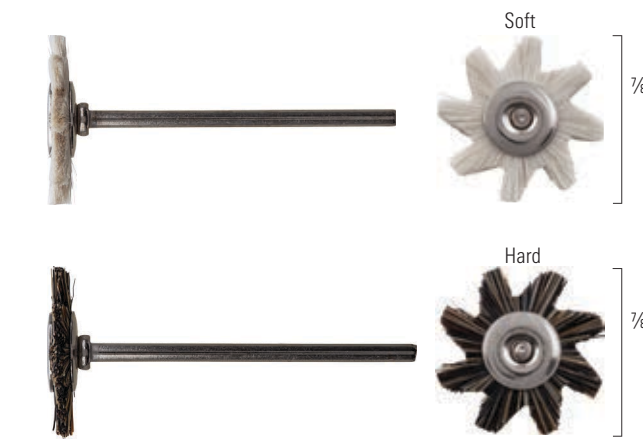

**MOUNTED MINIATURE BRUSHES**

These bristle brushes hold compound longer and keep their shape longer. They are made in Germany and layered with a chamomise insert.

Order # 16-7052



Grade	OD	Shank	Material	12+	6+	1+
Soft	7/8"	3/2"	White Goat Hair	\$18.45	\$19.25	\$20.05
Medium	7/8"	3/2"	Gray Goat Hair	\$18.45	\$19.25	\$20.05

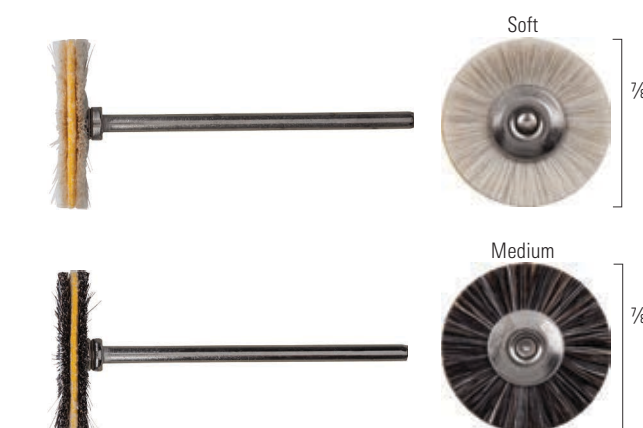

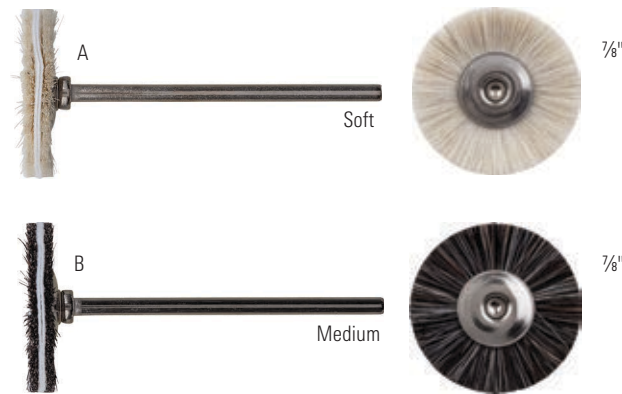

### MOUNTED MINIATURE BRUSHES

This mounted miniature brush is made with white goat hair. The zeta cloth insert is a fine cotton thread. They hold polish very well, and brushes tend to keep their shape longer.

Order # 16-7053

Item	Grade	Material	OD	Shank	12+	6+	1+
A	Soft	White Goat Hair	7/8"	3/32"	\$17.99	\$18.77	\$19.55
B	Medium	Gray Goat Hair	7/8"	3/32"	\$17.99	\$18.77	\$19.55

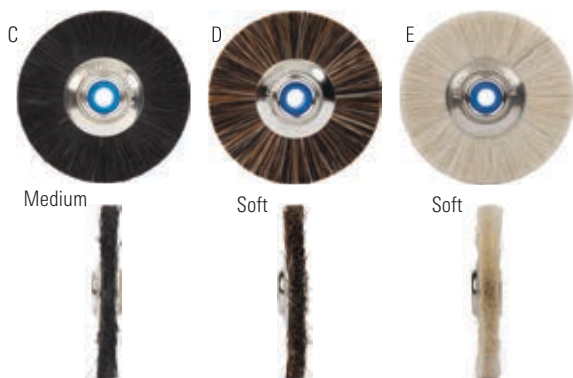

### UNMOUNTED SLIMLINE BRUSHES

The outstanding specialty of HATHO's Slimline Brushes lie within its construction. Numerous filling materials and diameters are available. For polishing very fine structures, choose a Slimline brush with Ø 48mm.

Order # 16-4002

Item	Grade	Center	OD	ID	12+	6+	1+
C	Medium	Plastic	48mm	6mm	\$5.06	\$5.28	\$5.50
D	Soft	Plastic	48mm	6mm	\$5.06	\$5.28	\$5.50
E	Stiff	Plastic	48mm	6mm	\$4.60	\$4.80	\$5.00

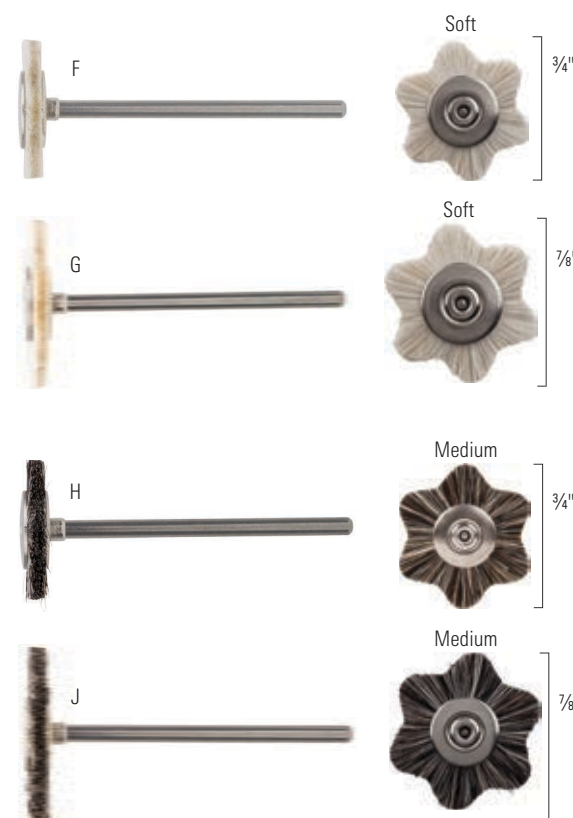

### MOUNTED MINIATURE BRUSHES

Astro brushes are special miniature brushes in a star design. Their shape is to optimally polish narrow and fine surfaces, such as filigree, effectively. Made in Germany with white goat hair. Astro brushes are for fine luster.

Order # 16-7054

Item	Grade	Material	OD	Shank	12+	6+	1+
F	Soft	White Goat Hair	3/4"	3/32"	\$11.36	\$11.86	\$12.35
G	Soft	White Goat Hair	7/8"	3/32"	\$11.36	\$11.86	\$12.35
H	Medium	Gray Goat Hair	3/4"	3/32"	\$11.36	\$11.86	\$12.35
J	Medium	Gray Goat Hair	7/8"	3/32"	\$11.36	\$11.86	\$12.35



Items sold each, unless noted otherwise.

### UNMOUNTED WOOD HUB BRUSHES

Premium-quality Chungking bristles. Hubs are made of seasoned hardwood and are precision bored for a perfect tapered-spindle fit.

Order # 16-25010

Hub Brush Style	Hub OD	Rows	Length	12+	6+	1+
1A	1 7/8"	1	5/8"	\$1.40	\$1.49	\$1.65
1B	1 7/8"	1	1/2"	\$1.40	\$1.49	\$1.65
1C	1 7/8"	1	3/8"	\$1.40	\$1.49	\$1.65
2A	1 7/8"	2	5/8"	\$1.62	\$1.71	\$1.90
2B	1 7/8"	2	1/2"	\$1.62	\$1.71	\$1.90
2C	1 7/8"	2	3/8"	\$1.62	\$1.71	\$1.90
6A	1 1/4"	2	5/8"	\$1.70	\$1.80	\$2.00
6B	1 1/4"	2	1/2"	\$1.70	\$1.80	\$2.00
6C	1 1/4"	2	3/8"	\$1.70	\$1.80	\$2.00
7A	1 1/4"	3	5/8"	\$2.98	\$3.15	\$3.50
7C	1 1/4"	3	3/8"	\$2.12	\$2.30	\$2.55
8A	1 1/4"	4	5/8"	\$2.82	\$3.06	\$3.40
8C	1 1/4"	4	3/8"	\$2.89	\$3.06	\$3.40

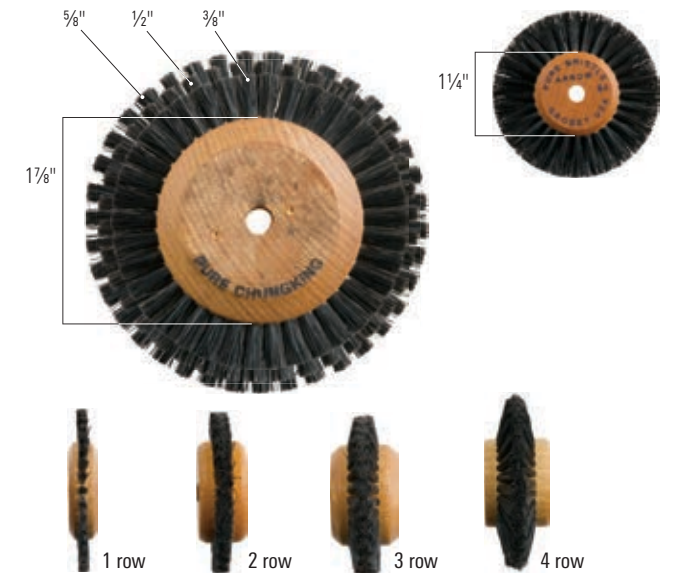

### UNMOUNTED METAL HUB BRUSHES

Metal hub brushes with nylon or lead centers.

Order # 16-25011

Grade	Center	OD	ID	12+	6+	1+
Stiff	Nylon	2"	1/8"	\$2.30	\$2.43	\$2.70
Stiff	Lead	2"	1/8"	\$3.02	\$3.20	\$3.55
Medium	Lead	2 1/2"	1/4"	\$15.32	\$15.98	\$16.65
Soft	Nylon	2"	1/8"	\$2.38	\$2.52	\$2.80
Soft	Lead	2"	1/8"	\$2.59	\$2.75	\$3.05

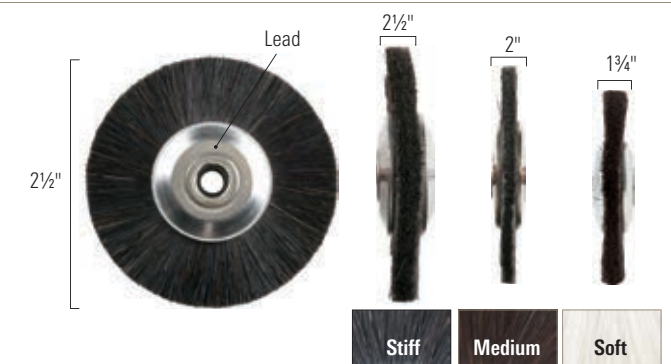

### MOUNTED MINIATURE BRUSHES

These mounted miniature brushes are extra soft. Use with low speeds (around 5,000 RPM) and light pressure to prep delicate surfaces.

Order # 16-7055

Grade	Material	OD	Shank	12+	6+	1+
Extra Soft	Scotch Brite	1"	3/32"	\$12.88	\$13.44	\$14.00
Extra Soft	Resin Bonded	1"	3/32"	\$13.89	\$14.50	\$15.10



### MOUNTED END BRUSHES

Made of white goat hair. These are excellent for finishing delicate or patterned metal.

Order # 16-7056

Grade	Material	OD	Shank	12+	6+	1+
Stiff	Nylon Filament	4"	3/32"	\$6.62	\$6.91	\$7.20
Soft	White Goat Hair	4"	3/32"	\$8.05	\$8.40	\$8.75
Extra Soft	White Goat Hair	6 1/2"	3/32"	\$11.73	\$12.24	\$12.75







Mandrel shown attached.  
(Motors not included).

**TAPERED CHUCK FOR BRUSHES**

Use with tapered spindle on polishing motors. Fits brushes with 1/8" holes. Can be threaded onto the hardened steel taper, which in turn can be threaded onto a standard tapered spindle.

Order # 47-25800

Item	Description	OD	12+	6+	1+
A	Right-Handed	1/8"	\$3.17	\$3.31	\$3.45
B	Left-Handed	1/8"	\$3.17	\$3.31	\$3.45



Mandrel shown attached.  
(Motors not included).

**WOODEN HUB MANDREL**

Wood adapter includes permanently mounted mandrel mounts on tapered spindle. Features a heavy-duty 1/16" diameter screw, holds miniature buffs, felts, brushes, etc., and fits all right-handed threaded spindles.

Item	Order #	Description	OD	12+	6+	1+
C	47-2600	Wood Hub Mandrel	1/8"	\$2.07	\$2.16	\$2.25



Mandrels shown attached.  
(Motor not included).

**PLASTIC HUB MANDREL**

Plastic hub mandrels designed to fit brushes with 1/8" arbor hole.

Item	Order #	Description	OD	12+	6+	1+
D	47-2608	Right-Handed	1/8"	\$6.59	\$6.98	\$7.75
E	47-2610	Left-Handed	1/8"	\$6.59	\$6.98	\$7.75



Mandrel shown attached.  
(Motor not included).

**WHEEL MANDRELS**

Hold rubber bonded abrasive wheels, grinding stones, sanding drums, brushes, and other accessories with 1/4" center mounting. Holds up to 3/4" thick.

Item	Order #	Description	Shank	12+	6+	1+
F	34-2013	Left Wheel Mandrel	5/16"	\$15.43	\$16.34	\$18.15
G	34-2014	Right Wheel Mandrel	5/16"	\$15.43	\$16.34	\$18.15

**WHEEL MANDREL**

For right-handed side of motor. Designed to hold wheels with 1/2" arbor hole. This arbor is excellent for use with clean and finish buffs. Wheel arbor fits shaft 1/2" diameter straight motor shaft. Used with unitized wheels this plastic mandrel self-tops into the wheel. Designed to hold grinding wheel on the right side of the motor with 1/2" straight shaft. For wheels with 1/2" hole.



Item	Order #	Description	OD	ID	Length	Shank	12+	6+	1+
H	47-2560	Right Arbor	1 3/4"	1/2"	4"	3/4"	\$16.70	\$17.42	\$18.15

Items sold each, unless noted otherwise.

**WOODEN FLUX BRUSH**

Order #	Description	Length	12+	6+	1+
16-2597	#4 Flux Brush	4"	\$2.12	\$2.21	\$2.30

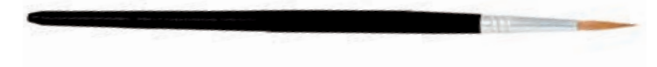

**EXTRA STIFF FLUX BRUSHES**

Excellent for use with flux and acid applications.



Item	Order #	Grade	OD	Length	12+	6+	1+
A	16-2256	Extra Stiff	1/4"	3 1/4"	\$1.70	\$1.78	\$1.85
B	16-2257	Extra Stiff	1/2"	5 3/4"	\$3.36	\$3.50	\$3.65



**FLUX BRUSH WITH TIN FERRULE**

Ideal for applying fluxes and other liquids. Inexpensive and disposable.



Order #	Description	12+	6+	1+
16-2250	Flux Brush	\$5.29	\$5.52	\$5.75



**RED SABLE BRUSHES**

Select pure-red sable tips are hand cupped with needle-sharp points. Bristles are mounted in aluminum seamless ferrules, which are mounted on wooden handles.

Order # 16-27010

- Brush Length 7 1/4"
- 2/0 (smallest), #7 (largest)
- Sold Each



Brush Size	3/0	2/0	#1	#2	#3	#4	#5	#6	#7
12+	\$2.16	\$0.83	\$1.01	\$1.01	\$1.20	\$1.52	\$1.79	\$2.07	\$2.39
6+	\$2.26	\$0.86	\$1.06	\$1.06	\$1.25	\$1.58	\$1.87	\$2.16	\$2.50
1+	\$2.35	\$0.90	\$1.10	\$1.10	\$1.30	\$1.65	\$1.95	\$2.25	\$2.60

All prices are subject to change. Visit [Stuller.com](http://Stuller.com) for our complete product selections, current pricing, and additional price breaks. | 111



**SCRATCH BRUSHES**

Scratch brushes have pen-shaped handles and come in four different styles. Used for removing rust or corrosion in hard-to-reach places. Clogged burs are best cleaned using the brass model. Bristle length can be adjusted as they wear down by twisting the cap. Includes one brush.

Order # 16-25012

Item	Description	Brush Length	Bristle Length	12+	6+	1+
A	Steel Scratch Brush	4½"	1½"	\$8.42	\$8.78	\$9.15
B	Nylon Scratch Brush	4½"	1½"	\$8.42	\$8.78	\$9.15
C	Fiberglass Scratch Brush	4½"	1½"	\$6.53	\$6.82	\$7.10
D	Brass Scratch Brush	4½"	1½"	\$8.10	\$8.45	\$8.80
E	Steel Refill (Pack of 6)	4½"	1½"	\$6.39	\$6.67	\$6.95
F	Nylon Refill (Pack of 6)	4½"	1½"	\$5.38	\$5.62	\$5.85
G	Fiberglass Refill (Pack of 6)	4½"	1½"	\$4.69	\$4.90	\$5.10
H	Brass Refill (Pack of 6)	4½"	1½"	\$5.93	\$6.19	\$6.45



**CLEANING UTILITY BRUSH**

Ideal for cleaning small parts while at the bench.

Item	Order #	Description	Length	Bristle Length	12+	6+	1+
J	16-0551	Nylon	7"	½"	\$2.39	\$2.50	\$2.60
J	16-0551	Brass	7"	½"	\$2.39	\$2.50	\$2.60
J	16-0551	Steel	7"	½"	\$2.39	\$2.50	\$2.60
K	16-0552	Nylon Double Ended	7"	1¾"	\$2.39	\$2.50	\$2.60



**BRASS BRUSH**

Bristles are finer than most and the handle is curved for better access.

Item	Order #	Grade	W×L	Brush	12+	6+	1+
A	16-3111	Fine Bristles	¾"×7¾"	1½"	\$8.33	\$8.82	\$9.80

**STAINLESS STEEL BRUSH**

Bristles are finer than most and the handle is curved for better access.

Item	Order #	Grade	W×L	Brush	12+	6+	1+
B	16-3112	Fine Bristles	¾"×7¾"	1½"	\$8.33	\$8.82	\$9.80

**BRASS SCRATCH BRUSH WITH WOODEN HANDLE**

Bristles firmly anchored in handles. Suitable for cleaning in and with solutions. Contains four rows of .003" wire.

Item	Order #	Grade	W×L	Brush	12+	6+	1+
C	16-3100	Medium Bristles	¾"×8¾"	3¼"	\$10.67	\$11.14	\$11.60

**GLASGOW WASHOUT BRUSHES**

Contains four rows of white bristles that are locked in a wooden handle. Used for cleaning PC boards and other washing applications. Made in Germany.

Item	Order #	Grade	Tool Length	Brush	12+	6+	1+
D	16-0598	Hard Bristles	10¾"	5¾"	\$6.44	\$6.72	\$7.00
E	16-0599	Medium Bristles	10¾"	5¾"	\$6.44	\$6.72	\$7.00

**PLASTIC HANDLE WASHOUT BRUSH**

Contains four rows of stiff, nylon bristles.

Item	Order #	Grade	W×L	Brush	12+	6+	1+
F	16-0540	Stiff Bristles	½"×7½"	3"	\$7.41	\$7.73	\$8.05

**BENCH DUSTER**

Makes cleaning your bench area quick and easy. This brush contains four rows of soft, black bristles mounted in a wooden handle. Ideal for sweeping filings and general purpose cleanup.

Item	Order #	Grade	W×L	Brush	12+	6+	1+
G	16-0510	Soft Bristles	2½"×9½"	4"	\$7.13	\$7.44	\$7.75

**MULTI-PURPOSE CLEANING BRUSH**

Contains four rows of nylon bristles mounted in an angled, Lucite handle.

Item	Order #	Grade	Tool Length	Brush	12+	6+	1+
H	16-0550	Medium Bristles	6¾"	1¾"	\$2.71	\$2.83	\$2.95

**HAND AND FINGERNAIL SCRUB BRUSH**

Designed to help clean hands and fingernails easily after working with jewelry and rouges. Bristles are nylon.

Item	Order #	Grade	W×L	12+	6+	1+
J	16-0520	Extra Soft	1½"×3½"	\$5.29	\$5.52	\$5.75





# BURS



### BUSCH® MASTER BUR KIT

Busch® Master Bur Kit contains 84 burs in an assortment of Round, 70 degree hart, 90 degree hart, bud, inverted cone, cylinder square, and setting burs, displayed in a wooden storage box. These German burs are made of exceptional quality and known for their precision which allows for accurate and smooth cutting.

Order #	Set of	Description	12+	6+	1+
19-3220	84	Master Bur Kit	\$247.30	\$268.16	\$297.95



ROUND, FIG. #1

mm	1.7	1.8	1.95	2.1	2.2	2.3	2.4	2.5	2.6	2.7	2.9	3.1	3.3
12+	\$4.97	\$4.97	\$4.97	\$4.97	\$4.97	\$4.97	\$11.18	\$11.18	\$11.18	\$11.18	\$11.18	\$17.02	\$17.02
6+	\$5.27	\$5.27	\$5.27	\$5.27	\$5.27	\$5.27	\$11.66	\$11.66	\$11.66	\$11.66	\$11.66	\$17.76	\$17.76
1+	\$5.85	\$5.85	\$5.85	\$5.85	\$5.85	\$5.85	\$12.15	\$12.15	\$12.15	\$12.15	\$12.15	\$18.50	\$18.50

mm	3.5	3.7	4.0	4.5	5.0	5.5	6.0	6.5	7.0	7.5	8.0	8.5
12+	\$17.02	\$17.02	\$19.98	\$19.98	\$19.98	\$5.65	\$5.65	\$5.65	\$7.01	\$7.01	\$7.01	\$7.01
6+	\$17.76	\$17.76	\$21.15	\$21.15	\$21.15	\$5.99	\$5.99	\$5.99	\$7.43	\$7.43	\$7.43	\$7.43
1+	\$18.50	\$18.50	\$23.50	\$23.50	\$23.50	\$6.65	\$6.65	\$6.65	\$8.25	\$8.25	\$8.25	\$8.25



### Order # 18-10000

Material Tungsten Vanadium Steel  
Head Shape Ball  
Shank Size 3/32"  
Sold in packs of 6

mm	0.25	0.3	0.35	0.4	0.5	0.6	0.7	0.8
12+	\$17.30	\$17.30	\$15.98	\$9.20	\$4.97	\$4.97	\$4.97	\$4.97
6+	\$18.05	\$18.05	\$16.92	\$9.60	\$5.27	\$5.27	\$5.27	\$5.27
1+	\$18.80	\$18.80	\$18.80	\$10.00	\$5.85	\$5.85	\$5.85	\$5.85

mm	0.9	1.0	1.1	1.2	1.3	1.4	1.5	1.6
12+	\$4.97	\$4.97	\$4.97	\$4.97	\$4.97	\$4.97	\$4.97	\$4.97
6+	\$5.27	\$5.27	\$5.27	\$5.27	\$5.27	\$5.27	\$5.27	\$5.27
1+	\$5.85	\$5.85	\$5.85	\$5.85	\$5.85	\$5.85	\$5.85	\$5.85

### Kit Order # 18-1886

15-Piece Bur Kit  
1.2mm-3.7mm

12+	\$36.06
6+	\$37.63
1+	\$39.20

### Order # 18-10001

Material Tungsten Vanadium Steel  
Head Shape 70 Degree Bur  
Shank Size 3/32"  
Sold in packs of 6

mm	1.0	1.2	1.4	1.6	1.8	2.1	2.3	2.5	2.7	2.9
12+	\$14.95	\$14.95	\$14.95	\$14.95	\$14.95	\$14.95	\$14.95	\$22.36	\$22.36	\$22.36
6+	\$15.60	\$15.60	\$15.60	\$15.60	\$15.60	\$15.60	\$15.60	\$23.33	\$23.33	\$23.33
1+	\$16.25	\$16.25	\$16.25	\$16.25	\$16.25	\$16.25	\$16.25	\$24.30	\$24.30	\$24.30

mm	3.1	3.3	3.5	3.7	4.0	4.2	4.5	4.7	5.0
12+	\$27.19	\$27.19	\$27.19	\$27.19	\$33.53	\$33.53	\$33.53	\$33.53	\$33.53
6+	\$28.37	\$28.37	\$28.37	\$28.37	\$34.99	\$34.99	\$34.99	\$34.99	\$34.99
1+	\$29.55	\$29.55	\$29.55	\$29.55	\$36.45	\$36.45	\$36.45	\$36.45	\$36.45



BUSCH® 70 DEGREE BEARING, FIG. #446

### Order # 18-10009

Material Tungsten Vanadium Steel  
Head Shape 90 Degree Bur  
Shank Size 3/32"  
Sold in packs of 6

mm	0.9	1.0	1.1	1.2	1.3	1.4	1.5
12+	\$13.81	\$13.81	\$13.81	\$13.81	\$13.81	\$13.81	\$13.81
6+	\$14.63	\$14.63	\$14.63	\$14.63	\$14.63	\$14.63	\$14.63
1+	\$16.25	\$16.25	\$16.25	\$16.25	\$16.25	\$16.25	\$16.25

mm	1.6	1.7	1.8	1.9	2.0	2.1	2.2	2.3
12+	\$13.81	\$13.81	\$13.81	\$13.81	\$13.81	\$13.81	\$13.81	\$13.81
6+	\$14.63	\$14.63	\$14.63	\$14.63	\$14.63	\$14.63	\$14.63	\$14.63
1+	\$16.25	\$16.25	\$16.25	\$16.25	\$16.25	\$16.25	\$16.25	\$16.25



BUSCH® 90 DEGREE BEARING, FIG. #156

mm	2.4	2.5	2.6	2.7	2.8	2.9	3.1	3.3	3.5	3.7	4.0	4.2	4.5	4.7	5.0
12+	\$20.66	\$20.66	\$20.66	\$20.66	\$20.66	\$20.66	\$27.19	\$27.19	\$27.19	\$27.19	\$33.53	\$33.53	\$33.53	\$33.53	\$33.53
6+	\$21.87	\$21.87	\$21.87	\$21.87	\$21.87	\$21.87	\$28.37	\$28.37	\$28.37	\$28.37	\$34.99	\$34.99	\$34.99	\$34.99	\$34.99
1+	\$24.30	\$24.30	\$24.30	\$24.30	\$24.30	\$24.30	\$29.55	\$29.55	\$29.55	\$29.55	\$36.45	\$36.45	\$36.45	\$36.45	\$36.45

### Order # 18-10005

Material Tungsten Vanadium Steel  
Head Shape Setting  
Shank Size 3/32"  
Sold Each

mm	1.0	1.25	1.5	1.75	2.0	2.25	2.5	2.75	3.0	3.25	3.5
12+	\$2.34	\$2.34	\$2.34	\$2.34	\$2.34	\$2.34	\$3.82	\$3.53	\$4.59	\$4.59	\$4.59
6+	\$2.48	\$2.48	\$2.48	\$2.48	\$2.48	\$2.48	\$3.98	\$3.74	\$4.86	\$4.86	\$4.86
1+	\$2.75	\$2.75	\$2.75	\$2.75	\$2.75	\$2.75	\$4.15	\$4.15	\$5.40	\$4.59	\$5.40

mm	3.75	4.0	4.25	4.5	4.75	5.0	5.5	6.0	7.0	8.0
12+	\$4.59	\$6.26	\$6.26	\$6.26	\$6.26	\$6.26	\$6.67	\$6.67	\$6.67	\$8.03
6+	\$4.86	\$6.53	\$6.53	\$6.53	\$6.53	\$6.53	\$7.07	\$7.07	\$7.07	\$8.51
1+	\$5.40	\$6.80	\$6.80	\$6.80	\$6.80	\$6.80	\$7.85	\$7.85	\$7.85	\$9.45

### Kit Order # 18-4075

16-Piece Bur Kit  
(1 each) 1.0mm-8.0mm

12+	\$88.27
6+	\$92.11
1+	\$95.95



BUSCH® STONE SETTING BURS, FIG. #413



**Order # 18-5001**

Material Tungsten Vanadium Steel  
 Head Shape Cup  
 Shank Size 3/32"  
 Sold in packs of 6

mm	0.8	0.9	1.0	1.1	1.2	1.3	1.4	1.5	1.6	1.7
12+	\$17.09	\$17.09	\$17.09	\$17.09	\$17.09	\$17.09	\$17.09	\$17.09	\$17.09	\$17.09
6+	\$18.09	\$18.09	\$18.09	\$18.09	\$18.09	\$18.09	\$18.09	\$18.09	\$18.09	\$18.09
1+	\$20.10	\$20.10	\$20.10	\$20.10	\$20.10	\$20.10	\$20.10	\$20.10	\$20.10	\$20.10

mm	1.8	1.9	2.0	2.1	2.2	2.3
12+	\$17.09	\$17.09	\$17.09	\$17.09	\$17.09	\$17.09
6+	\$18.09	\$18.09	\$18.09	\$18.09	\$18.09	\$18.09
1+	\$20.10	\$20.10	\$20.10	\$20.10	\$20.10	\$20.10



BUSCH® TWINCUT CUP BUR

**Kit Order # 18-5000**

**12-Piece Bur Kit**  
 (1 each) 1.3mm–4.0mm

12+	\$45.52
6+	\$48.20
1+	\$53.55



**Order # 18-5006**

Material Tungsten Vanadium Steel  
 Head Shape Cup  
 Shank Size 3/32"  
 Sold in packs of 6

mm	0.8	0.9	1.0	1.1	1.2	1.3	1.4	1.5	1.6	1.7
12+	\$18.49	\$18.49	\$18.49	\$18.49	\$18.49	\$18.49	\$18.49	\$18.49	\$18.49	\$18.49
6+	\$19.30	\$19.30	\$19.30	\$19.30	\$19.30	\$19.30	\$19.30	\$19.30	\$19.30	\$19.30
1+	\$20.10	\$20.10	\$20.10	\$20.10	\$20.10	\$20.10	\$20.10	\$20.10	\$20.10	\$20.10

mm	1.8	1.9	2.0	2.1	2.2	2.3
12+	\$18.49	\$18.49	\$18.49	\$18.49	\$18.49	\$18.49
6+	\$19.30	\$19.30	\$19.30	\$19.30	\$19.30	\$19.30
1+	\$20.10	\$20.10	\$20.10	\$20.10	\$20.10	\$20.10



BUSCH® TWINCUT CONICAL CUP BUR

**Kit Order # 18-5005**

**12-Piece Bur Kit**  
 (1 each) 1.3mm–4.0mm

12+	\$45.52
6+	\$48.20
1+	\$53.55



BUSCH® FAST-CUT CUP BURS, FIG. #411C

**Order # 18-10013**

Material Tungsten Vanadium Steel  
 Head Shape Cup  
 Shank Size 3/32"  
 Sold Each

mm	1.0	1.2	1.4	1.5	1.6	1.8	2.1	2.3
12+	\$2.62	\$2.62	\$2.62	\$2.62	\$2.62	\$2.62	\$2.62	\$2.62
6+	\$2.74	\$2.74	\$2.74	\$2.74	\$2.74	\$2.74	\$2.74	\$2.74
1+	\$2.85	\$2.85	\$2.85	\$2.85	\$2.85	\$2.85	\$2.85	\$2.85

**Order # 18-10016**

Material Tungsten Vanadium Steel  
 Head Shape Cup  
 Shank Size 3/32"  
 Sold Each

mm	0.9	1.0	1.2	1.4	1.5	1.6	1.8	2.1	2.3
12+	\$2.42	\$2.42	\$2.42	\$2.42	\$2.42	\$2.42	\$2.42	\$2.42	\$2.42
6+	\$2.57	\$2.57	\$2.57	\$2.57	\$2.57	\$2.57	\$2.57	\$2.57	\$2.57
1+	\$2.85	\$2.85	\$2.85	\$2.85	\$2.85	\$2.85	\$2.85	\$2.85	\$2.85

mm	2.5	2.7	2.9	3.1
12+	\$4.08	\$4.08	\$4.08	\$4.08
6+	\$4.32	\$4.32	\$4.32	\$4.32
1+	\$4.80	\$4.80	\$4.80	\$4.80

**Kit Order # 18-1530**

**13-Piece Bur Kit**  
 (1 each) 0.9mm–3.1mm

12+	\$46.28
6+	\$48.29
1+	\$50.30



BUSCH® CUP BURS, FIG. #77B

**Order # 18-10007**

Material Tungsten Vanadium Steel  
 Head Shape Inverted Cone  
 Shank Size 3/32"  
 Sold in packs of 6

mm	0.6	0.7	0.8	0.9	1.2	1.4	1.6	1.8	2.1	2.3
12+	\$4.97	\$4.97	\$4.97	\$4.97	\$4.97	\$4.97	\$4.97	\$4.97	\$4.97	\$4.97
6+	\$5.27	\$5.27	\$5.27	\$5.27	\$5.27	\$5.27	\$5.27	\$5.27	\$5.27	\$5.27
1+	\$5.85	\$5.85	\$5.85	\$5.85	\$5.85	\$5.85	\$5.85	\$5.85	\$5.85	\$5.85



BUSCH® INVERTED CONE, FIG. #3





**Order # 18-10003**

Material Tungsten Vanadium Steel  
 Head Shape Bud  
 Shank Size 3/32"  
 Sold Each



mm	0.6	0.7	0.8	0.9	1.0	1.2	1.4	1.5	1.6	1.8	2.1
12+	\$5.61	\$5.61	\$5.61	\$5.61	\$5.61	\$5.61	\$5.61	\$5.61	\$5.61	\$5.61	\$5.61
6+	\$5.94	\$5.94	\$5.94	\$5.94	\$5.94	\$5.94	\$5.94	\$5.94	\$5.94	\$5.94	\$5.94
1+	\$6.60	\$6.60	\$6.60	\$6.60	\$6.60	\$6.60	\$6.60	\$6.60	\$6.60	\$6.60	\$6.60

mm	2.3	2.5	2.7	2.9	3.1	3.3	3.5	3.7	4.0
12+	\$5.61	\$12.20	\$12.20	\$12.20	\$17.17	\$17.17	\$17.17	\$17.17	\$23.64
6+	\$5.94	\$12.92	\$12.92	\$12.92	\$18.18	\$18.18	\$18.18	\$18.18	\$24.67
1+	\$6.60	\$14.35	\$14.35	\$14.35	\$20.20	\$20.20	\$20.20	\$20.20	\$25.70

BUSCH® BUD BUR, FIG. #6



**Order # 18-10002**

Material Tungsten Vanadium Steel  
 Head Shape Cylinder  
 Shank Size 3/32"  
 Sold Each



mm	0.7	0.8	0.9	1.0	1.2	1.4	1.6	1.8	2.1
12+	\$8.14	\$8.14	\$8.14	\$8.14	\$8.14	\$8.14	\$8.14	\$8.14	\$8.14
6+	\$8.50	\$8.50	\$8.50	\$8.50	\$8.50	\$8.50	\$8.50	\$8.50	\$8.50
1+	\$8.85	\$8.85	\$8.85	\$8.85	\$8.85	\$8.85	\$8.85	\$8.85	\$8.85

mm	2.3	2.5	2.7	3.1
12+	\$7.52	\$15.51	\$15.51	\$18.77
6+	\$7.97	\$16.43	\$16.43	\$19.58
1+	\$8.85	\$18.25	\$18.25	\$20.40

BUSCH® CONE, SQUARE CROSS-CUT, FIG. #23



**Order # 18-10006**

Material Tungsten Vanadium Steel  
 Head Shape Krause  
 Shank Size 3/32"  
 Sold in packs of 6



mm	1.0	1.2
12+	\$16.07	\$16.07
6+	\$17.01	\$17.01
1+	\$18.90	\$18.90

BUSCH® KRAUSE BURS, FIG. #256

**Order # 18-10008**

Material Tungsten Vanadium Steel  
 Head Shape Cylinder  
 Shank Size 3/32"  
 Sold in packs of 6



mm	0.6	0.7	0.8	0.9	1.0	1.2	1.4	1.6	1.8	2.1
12+	\$7.52	\$7.52	\$7.52	\$7.52	\$7.52	\$7.52	\$7.52	\$7.52	\$7.52	\$7.52
6+	\$7.97	\$7.97	\$7.97	\$7.97	\$7.97	\$7.97	\$7.97	\$7.97	\$7.97	\$7.97
1+	\$8.85	\$8.85	\$8.85	\$8.85	\$8.85	\$8.85	\$8.85	\$8.85	\$8.85	\$8.85

mm	2.3	2.5	2.7	2.9	3.1
12+	\$7.52	\$15.51	\$15.51	\$15.51	\$18.77
6+	\$7.97	\$16.43	\$16.43	\$16.43	\$19.58
1+	\$8.85	\$18.25	\$18.25	\$18.25	\$20.40



BUSCH® CYLINDER, SPECIAL CROSS-CUT, FIG. #21

**Order # 18-10004**

Material Tungsten Vanadium Steel  
 Head Shape Cylinder  
 Shank Size 3/32"  
 Sold in packs of 6



mm	0.7	0.8	0.9	1.0	1.2	1.4	1.6	1.8	2.1	2.3	3.1
12+	\$8.14	\$8.14	\$8.14	\$8.14	\$8.14	\$8.14	\$8.14	\$8.14	\$8.14	\$8.14	\$17.34
6+	\$8.50	\$8.50	\$8.50	\$8.50	\$8.50	\$8.50	\$8.50	\$8.50	\$8.50	\$8.50	\$18.36
1+	\$8.85	\$8.85	\$8.85	\$8.85	\$8.85	\$8.85	\$8.85	\$8.85	\$8.85	\$8.85	\$20.40



BUSCH® CYLINDER, SPECIAL SINGLE-CUT, FIG. #15

**Order # 18-10010**

Material Tungsten Vanadium Steel  
 Head Shape Wheel  
 Shank Size 3/32"  
 Sold Each

mm	6.0	7.0	8.0	10.0	12.0	14.0
12+	\$13.22	\$13.22	\$13.22	\$18.79	\$25.21	\$25.53
6+	\$14.00	\$14.00	\$14.00	\$19.89	\$26.30	\$26.64
1+	\$15.55	\$15.55	\$15.55	\$22.10	\$27.40	\$27.75



BUSCH® KNIFE EDGE WHEEL BUR

**Order # 18-10011**

Material Tungsten Vanadium Steel  
 Head Shape Wheel  
 Shank Size 3/32"  
 Sold Each

mm	2.3	4.0	5.0	6.0	8.0	10
12+	\$2.13	\$5.06	\$5.06	\$8.88	\$11.43	\$10.41
6+	\$2.25	\$5.36	\$5.36	\$9.41	\$12.11	\$11.03
1+	\$2.50	\$5.95	\$5.95	\$10.45	\$13.45	\$12.25



BUSCH® WHEEL BUR WITH SAW EDGE, FIG. #231S



BUSCH® CARBIDE BALL BUR

**Order # 18-5189**

Material Carbide Steel  
 Head Shape Ball  
 Shank Size 3/32"  
 Sold Each

mm	0.5	0.6	0.7	0.8	0.9	1.0
1+	\$4.15	\$4.15	\$4.15	\$4.15	\$4.15	\$4.15



CARBIDE BURS

**Order # 20-2825**

Material Carbide Steel  
 Head Shape Round  
 Shank Size 3/32"  
 Sold Each

mm	0.1	0.4
12+	\$14.90	\$8.37
6+	\$15.55	\$8.74
1+	\$16.20	\$9.10



STULLER SELECT ROUND CARBIDE BURS

**Order # 18-10012**

Material Tungsten Carbide Steel  
 Head Shape Ball  
 Shank Size 3/32"  
 Pack of 5

mm	0.5	0.6	0.7	0.8	0.9	1.0	1.2
12+	\$8.23	\$8.23	\$8.23	\$8.23	\$8.23	\$8.23	\$8.23
6+	\$8.59	\$8.59	\$8.59	\$8.59	\$8.59	\$8.59	\$8.59
1+	\$8.95	\$8.95	\$8.95	\$8.95	\$8.95	\$8.95	\$8.95

mm	1.4	1.6	1.8	2.1	2.3	2.7
12+	\$8.23	\$8.23	\$8.23	\$8.23	\$8.23	\$15.78
6+	\$8.59	\$8.59	\$8.59	\$8.59	\$8.59	\$16.46
1+	\$8.95	\$8.95	\$8.95	\$8.95	\$8.95	\$17.15

**Kit Order # 20-1040**

**18-Piece Bur Kit**  
 (1 each) 0.5mm-4.0mm

12+	\$46.87
6+	\$48.91
1+	\$50.95



**PANTHER® SETTING BUR KIT**

This kit consists of 20 setting burs neatly displayed in a wooden box. Made of the finest quality tool steel, these burs display exceptional durability and performance.

Order #	Set of	Description	12+	6+	1+
19-3152	20	1 each: .90mm-5.00mm	\$75.57	\$81.95	\$91.05



**PANTHER® BALL BUR KIT**

This ball bur kit consists of a wooden box with 20 burs made of the finest quality tool steel. These are very durable burs with an exceptional history of durability and performance.

Order #	Set of	Description	12+	6+	1+
19-3160	18	1 each: .90mm-4.50mm	\$44.45	\$48.20	\$53.55



**PANTHER® MASTER BUR KIT**

This 82-piece master bur kit is German made of the finest quality hardened tool steel. This consists of a wooden box displayed with 90 degree, 70 degree, round, bud, setting, cylinder, and square cone burs.

Order #	Set of	Description	12+	6+	1+
19-3860	82	Master Bur Kit	\$168.95	\$183.20	\$203.55







### THE MARK OF EXCELLENCE

Made in Germany, Panther® has earned a reputation for the highest standards in precision tool production in the world. Our burs and tools are manufactured on the most technically advanced computer-assisted machinery in existence. Only the finest quality hardened tool steel is used. Each tool is individually hand inspected before leaving the factory. Our highly trained technicians take pride in producing the most exceptional, durable precision burs available anywhere. Once you experience the performance of a Panther bur, you will never accept a substitute.

#### Order # 77-10003

Material Tungsten Vanadium Steel  
Head Shape Ball  
Shank Size 3/32"  
Sold in packs of 6

mm	0.3	0.4	0.5	0.6	0.9	1.0	1.1	1.2	1.3	1.4
12+	\$3.31	\$3.31	\$2.99	\$2.99	\$2.99	\$2.99	\$2.99	\$2.99	\$2.99	\$2.99
6+	\$3.46	\$3.46	\$3.24	\$3.24	\$3.24	\$3.24	\$3.24	\$3.24	\$3.24	\$3.24
1+	\$3.60	\$3.60	\$3.60	\$3.60	\$3.60	\$3.60	\$3.60	\$3.60	\$3.60	\$3.60

mm	1.5	1.6	1.7	1.8	1.9	2.0	2.1	2.2	2.3	2.4
12+	\$2.99	\$2.99	\$2.99	\$2.99	\$2.99	\$2.99	\$2.99	\$2.99	\$2.99	\$6.12
6+	\$3.24	\$3.24	\$3.24	\$3.24	\$3.24	\$3.24	\$3.24	\$3.24	\$3.24	\$6.48
1+	\$3.60	\$3.60	\$3.60	\$3.60	\$3.60	\$3.60	\$3.60	\$3.60	\$3.60	\$7.20

mm	2.5	2.6	2.7	2.8	2.9	3.0	3.1	3.3	3.5	3.7
12+	\$6.12	\$6.12	\$6.12	\$6.12	\$6.12	\$6.12	\$6.12	\$7.06	\$7.06	\$7.06
6+	\$6.48	\$6.48	\$6.48	\$6.48	\$6.48	\$6.48	\$6.48	\$7.47	\$7.47	\$7.47
1+	\$7.20	\$7.20	\$7.20	\$7.20	\$7.20	\$7.20	\$7.20	\$8.30	\$8.30	\$8.30

mm	4.0	4.2	4.5	4.7	5.0	5.5	6.0	6.5	7.0
12+	\$7.06	\$7.06	\$20.87	\$20.87	\$20.87	\$27.33	\$27.33	\$27.33	\$27.33
6+	\$7.47	\$7.47	\$22.64	\$22.64	\$22.64	\$28.94	\$28.94	\$28.94	\$28.94
1+	\$8.30	\$8.30	\$25.15	\$25.15	\$25.15	\$32.15	\$32.15	\$32.15	\$32.15

#### Kit Order #

	77-1097	77-1098	77-1099
12-Piece Bur Kit (1 each)	.50mm-2.5mm	3.1mm-8.0mm	.40mm-3.1mm
12+	\$7.65	\$41.44	\$14.20
6+	\$8.10	\$43.88	\$15.03
1+	\$9.00	\$48.75	\$16.70



PANTHER® ROUND BURS, FIG. #1



#### SYNTHETIC BEESWAX

When rubbed on a surface, it leaves a film on which a design can be marked.

Order #	Description	12+	6+	1+
26-1000	Beeswax	\$3.54	\$3.70	\$3.85



#### Order # 77-10004

Material Tungsten Vanadium Steel  
Head Shape 90 Degree Bur  
Shank Size 3/32"  
Sold in packs of 6

#### Kit Order #

	77-1197	77-1198	77-1199
12-Piece Bur Kit (1 each)	.90mm-3.5mm	2.7mm-5.0mm	.90mm-4.5mm
12+	\$20.23	\$21.42	\$23.80
6+	\$33.41	\$35.37	\$39.30
1+	\$46.54	\$49.28	\$54.75

mm	0.5	0.6	0.7	0.8	0.9	1.0	1.1	1.2	1.3	1.4
12+	\$7.78	\$7.78	\$7.78	\$7.78	\$7.78	\$7.78	\$7.78	\$7.78	\$7.78	\$7.78
6+	\$8.24	\$8.24	\$8.24	\$8.24	\$8.24	\$8.24	\$8.24	\$8.24	\$8.24	\$8.24
1+	\$9.15	\$9.15	\$9.15	\$9.15	\$9.15	\$9.15	\$9.15	\$9.15	\$9.15	\$9.15

mm	1.5	1.6	1.7	1.8	1.9	2.0	2.1	2.2	2.3	2.4
12+	\$7.78	\$7.78	\$7.78	\$7.78	\$7.78	\$7.78	\$7.78	\$7.78	\$7.78	\$11.94
6+	\$8.24	\$8.24	\$8.24	\$8.24	\$8.24	\$8.24	\$8.24	\$8.24	\$8.24	\$12.65
1+	\$9.15	\$9.15	\$9.15	\$9.15	\$9.15	\$9.15	\$9.15	\$9.15	\$9.15	\$14.05

mm	2.5	2.7	2.9	3.0	3.1	3.3	3.5	3.7	4.0	4.2
12+	\$11.94	\$11.94	\$11.94	\$11.94	\$11.94	\$11.94	\$11.94	\$17.26	\$17.26	\$17.26
6+	\$12.65	\$12.65	\$12.65	\$12.65	\$12.65	\$12.65	\$12.65	\$18.27	\$18.27	\$18.27
1+	\$14.05	\$14.05	\$14.05	\$14.05	\$14.05	\$14.05	\$14.05	\$20.30	\$20.30	\$20.30

mm	4.5	4.7	5.0
12+	\$17.26	\$17.26	\$17.26
6+	\$18.27	\$18.27	\$18.27
1+	\$20.30	\$20.30	\$20.30



PANTHER® 90 DEGREE HART BURS, FIG. #156C

#### Order # 77-10005

Material Tungsten Vanadium Steel  
Head Shape 70 Degree Bur  
Shank Size 3/32"  
Sold in packs of 6

#### Kit Order # 77-1299

	12-Piece Bur Kit (1 each) 1.0mm-2.9mm
12+	\$20.23
6+	\$21.42
1+	\$23.80

mm	0.9	1.0	1.1	1.2	1.3	1.4	1.5	1.6	1.7	1.8
12+	\$7.78	\$7.78	\$7.78	\$7.78	\$7.78	\$7.78	\$7.78	\$7.78	\$7.78	\$7.78
6+	\$8.24	\$8.24	\$8.24	\$8.24	\$8.24	\$8.24	\$8.24	\$8.24	\$8.24	\$8.24
1+	\$9.15	\$9.15	\$9.15	\$9.15	\$9.15	\$9.15	\$9.15	\$9.15	\$9.15	\$9.15

mm	1.9	2.0	2.1	2.2	2.3	2.5	2.7	2.9	3.1	3.3
12+	\$7.78	\$7.78	\$7.78	\$7.78	\$7.78	\$13.35	\$13.35	\$13.35	\$16.85	\$16.85
6+	\$8.24	\$8.24	\$8.24	\$8.24	\$8.24	\$14.13	\$14.13	\$14.13	\$18.27	\$18.27
1+	\$9.15	\$9.15	\$9.15	\$9.15	\$9.15	\$15.70	\$15.70	\$15.70	\$20.30	\$20.30

mm	3.5	3.7	4.7
12+	\$18.68	\$24.86	\$24.86
6+	\$19.49	\$26.96	\$26.96
1+	\$20.30	\$29.95	\$29.95



PANTHER® 70 DEGREE HART THIN BURS, FIG. #446



**Order # 77-10000**

Material Tungsten Vanadium Steel  
 Head Shape Bud  
 Shank Size 3/32"  
 Sold in packs of 6

mm	0.6	0.7	0.8	0.9	1.0	1.2	1.4	1.5	1.6	1.8
12+	\$4.36	\$4.36	\$4.36	\$4.36	\$4.36	\$4.36	\$4.36	\$4.36	\$4.36	\$4.36
6+	\$4.73	\$4.73	\$4.73	\$4.73	\$4.73	\$4.73	\$4.73	\$4.73	\$4.73	\$4.73
1+	\$5.25	\$5.25	\$5.25	\$5.25	\$5.25	\$5.25	\$5.25	\$5.25	\$5.25	\$5.25

mm	2.1	2.3	2.5	2.7	2.9	3.1	3.3	3.5	3.7	4.0
12+	\$4.36	\$4.36	\$9.42	\$9.42	\$9.42	\$9.42	\$9.42	\$9.42	\$9.42	\$17.30
6+	\$4.73	\$4.73	\$10.22	\$10.22	\$10.22	\$10.22	\$10.22	\$10.22	\$10.22	\$18.32
1+	\$5.25	\$5.25	\$11.35	\$11.35	\$11.35	\$11.35	\$11.35	\$11.35	\$11.35	\$20.35

mm	4.2	4.5	4.7	5.0
12+	\$17.30	\$17.30	\$17.30	\$17.30
6+	\$18.32	\$18.32	\$18.32	\$18.32
1+	\$20.35	\$20.35	\$20.35	\$20.35



PANTHER® BUD BURS, FIG. #6

**Kit Order # 77-1560**

**12-Piece Bur Kit**  
 (1 each) .90mm–3.1mm

12+	\$10.67
6+	\$11.30
1+	\$12.55



**Kit Order # 77-1640**

**12-Piece Bur Kit**  
 (1 each) .90mm–3.1mm

Material Tungsten Vanadium Steel  
 Head Shape Cone  
 Shank Size 3/32"  
 Sold in packs of 6

12+	\$11.65
6+	\$12.33
1+	\$13.70

mm	0.8	0.9	1.0	1.2	1.4	1.6	1.8	2.1	2.2
12+	\$4.36	\$4.36	\$4.36	\$4.36	\$4.36	\$4.36	\$4.36	\$4.36	\$4.36
6+	\$4.73	\$4.73	\$4.73	\$4.73	\$4.73	\$4.73	\$4.73	\$4.73	\$4.73
1+	\$5.25	\$5.25	\$5.25	\$5.25	\$5.25	\$5.25	\$5.25	\$5.25	\$5.25

mm	2.3	2.5	3.0	3.1
12+	\$4.36	\$8.22	\$8.22	\$8.22
6+	\$4.73	\$8.91	\$8.91	\$8.91
1+	\$5.25	\$9.90	\$9.90	\$9.90



PANTHER® CONE BURS, FIG. #5

**Order # 77-10002**

Material Tungsten Vanadium Steel  
 Head Shape Krause  
 Shank Size 3/32"  
 Sold in packs of 6

mm	1.0	1.2
12+	\$11.33	\$11.33
6+	\$12.29	\$12.29
1+	\$13.65	\$13.65



PANTHER® KRAUSE BURS, FIG. #256

**Order # 77-10007**

Material Tungsten Vanadium Steel  
 Head Shape Setting  
 Shank Size 3/32"  
 Sold in packs of 6

**Kit Order #**

	77-1497	77-1498	77-1499
	<b>12-Piece Bur Kit</b> (1 each) 1.0mm–11.0mm	<b>12-Piece Bur Kit</b> (1 each) 3.0mm–8.0mm	<b>24-Piece Bur Kit</b> (1 each) 1.0mm–6.0mm
12+	\$23.80	\$39.44	\$54.61
6+	\$25.20	\$41.76	\$57.83
1+	\$28.00	\$46.40	\$64.25

mm	0.9	1.0	1.2	1.3	1.4	1.5	1.6	1.7	1.8	1.9	2.0
12+	\$9.18	\$9.18	\$9.18	\$9.18	\$9.18	\$9.18	\$9.18	\$9.18	\$9.18	\$9.18	\$9.18
6+	\$9.72	\$9.72	\$9.72	\$9.72	\$9.72	\$9.72	\$9.72	\$9.72	\$9.72	\$9.72	\$9.72
1+	\$10.80	\$10.80	\$10.80	\$10.80	\$10.80	\$10.80	\$10.80	\$10.80	\$10.80	\$10.80	\$10.80

mm	2.1	2.2	2.3	2.4	2.5	2.7	2.9	3.0	3.1	3.3	3.5
12+	\$9.18	\$9.18	\$9.18	\$13.86	\$13.86	\$13.86	\$13.86	\$13.86	\$13.86	\$13.86	\$13.86
6+	\$9.72	\$9.72	\$9.72	\$15.03	\$15.03	\$15.03	\$15.03	\$15.03	\$15.03	\$15.03	\$15.03
1+	\$10.80	\$10.80	\$10.80	\$16.70	\$16.70	\$16.70	\$16.70	\$16.70	\$16.70	\$16.70	\$16.70

mm	3.7	4.0	4.2	4.5	4.7	5.0	6.0	7.0	8.0
12+	\$19.25	\$19.25	\$19.25	\$19.25	\$19.25	\$19.25	\$24.24	\$24.24	\$24.24
6+	\$20.39	\$20.39	\$20.39	\$20.39	\$20.39	\$20.39	\$26.28	\$26.28	\$26.28
1+	\$22.65	\$22.65	\$22.65	\$22.65	\$22.65	\$22.65	\$29.20	\$29.20	\$29.20



PANTHER® STONE SETTING BURS, FIG. #413

## Burs Quick Shop

The world of burs can be overwhelming.

With so many shapes, sizes, and metal qualities, and such a complex variety of possible tasks, it can be difficult to pinpoint essential items.

We've tried to do this work for you by showcasing a balanced selection of our most popular burs. Whether the task be stone setting, wax carving, drilling, deburring, filing, or engraving, Stuller has what you need to get the job done.

Visit [Stuller.com/Burs](http://Stuller.com/Burs) for more information.







INVERTED CONE BURS, FIG. #3

**Order # 77-10011**

Material Tungsten Vanadium Steel  
 Head Shape Inverted Cone  
 Shank Size 3/32"  
 Sold in packs of 6

mm	0.6	0.7	0.8	0.9	1.0	1.2	1.4	1.6	1.8
12+	\$3.24	\$3.24	\$3.24	\$3.24	\$3.24	\$3.24	\$3.24	\$3.24	\$3.24
6+	\$3.51	\$3.51	\$3.51	\$3.51	\$3.51	\$3.51	\$3.51	\$3.51	\$3.51
1+	\$3.90	\$3.90	\$3.90	\$3.90	\$3.90	\$3.90	\$3.90	\$3.90	\$3.90

mm	2.1	2.3	2.5	2.9
12+	\$3.24	\$3.24	\$8.56	\$8.56
6+	\$3.51	\$3.51	\$8.93	\$8.93
1+	\$3.90	\$3.90	\$9.30	\$9.30



**Kit Order # 77-1840**

**12-Piece Bur Kit**  
 (1 each) .60mm–2.3mm

12+	\$7.10
6+	\$7.52
1+	\$8.35



PANTHER® CIRCULAR EDGE BURS,

**Order # 77-10010**

Material Tungsten Vanadium Steel  
 Head Shape Wheel  
 Shank Size 3/32"  
 Sold in packs of 6

mm	2.3	2.9	3.5	4.0
12+	\$8.18	\$11.66	\$11.66	\$16.10
6+	\$8.87	\$12.65	\$12.65	\$17.46
1+	\$9.85	\$14.05	\$14.05	\$19.40



**Kit Order # 77-1740**

**12-Piece Bur Kit**  
 (1 each) .60mm–2.5mm

12+	\$7.65
6+	\$8.10
1+	\$9.00

**Order # 77-10009**

Material Tungsten Vanadium Steel  
 Head Shape Wheel  
 Shank Size 3/32"  
 Sold in packs of 6

mm	0.6	0.7	0.8	0.9	1.0	1.2	1.4	1.6	1.8
12+	\$2.99	\$2.99	\$2.99	\$2.99	\$2.99	\$2.99	\$3.57	\$3.24	\$3.24
6+	\$3.24	\$3.24	\$3.24	\$3.24	\$3.24	\$3.24	\$3.87	\$3.51	\$3.51
1+	\$3.60	\$3.60	\$3.60	\$3.60	\$3.60	\$3.60	\$4.30	\$3.90	\$3.90

mm	2.1	2.3	2.5	2.8
12+	\$3.24	\$3.57	\$6.38	\$6.38
6+	\$3.51	\$3.87	\$6.75	\$6.75
1+	\$3.90	\$4.30	\$7.50	\$7.50



PANTHER® WHEEL BURS, FIG. #2



WHEEL BURS, FIG. #431

**Order # 77-10008**

Material Tungsten Vanadium Steel  
 Head Shape Wheel  
 Shank Size 3/32"  
 Sold in packs of 6

mm	1.5	2.0
12+	\$9.44	\$9.44
6+	\$9.99	\$9.99
1+	\$11.10	\$11.10



**Order # 77-10006**

Material Tungsten Vanadium Steel  
 Head Shape Knife-Edge  
 Shank Size 3/32"  
 Sold in packs of 6

**Kit Order # 77-1398**

**12-Piece Bur Kit**  
 (1 each) .90mm–9.0mm

12+	\$37.40
6+	\$39.60
1+	\$44.00

mm	0.9	1.0	1.2	1.3	1.4	1.5	1.6	1.7	1.8
12+	\$7.78	\$7.78	\$7.78	\$7.78	\$7.78	\$7.78	\$7.78	\$7.78	\$7.78
6+	\$8.24	\$8.24	\$8.24	\$8.24	\$8.24	\$8.24	\$8.24	\$8.24	\$8.24
1+	\$9.15	\$9.15	\$9.15	\$9.15	\$9.15	\$9.15	\$9.15	\$9.15	\$9.15

mm	1.9	2.0	2.2	2.3	2.5	2.7	3.0	3.1	3.5
12+	\$7.78	\$7.78	\$7.78	\$7.78	\$11.94	\$11.94	\$11.94	\$11.94	\$11.94
6+	\$8.24	\$8.24	\$8.24	\$8.24	\$12.65	\$12.65	\$12.65	\$12.65	\$12.65
1+	\$9.15	\$9.15	\$9.15	\$9.15	\$14.05	\$14.05	\$14.05	\$14.05	\$14.05

mm	4.0	5.0	7.0	8.0	9.0
12+	\$17.26	\$17.26	\$24.78	\$24.78	\$42.08
6+	\$18.27	\$18.27	\$26.24	\$26.24	\$44.55
1+	\$20.30	\$20.30	\$29.15	\$29.15	\$49.50



PANTHER® KNIFE-EDGE CUT BURS, FIG. #249



PANTHER® CYLINDER CROSS-CUT BURS, FIG. #21

**Order # 77-10013**

Material Tungsten Vanadium Steel  
 Head Shape Cylinder  
 Shank Size 3/32"  
 Sold in packs of 6

mm	0.6	0.7	0.8	0.9	1.0	1.2	1.4	1.6	1.8	2.1
12+	\$3.57	\$3.57	\$3.57	\$3.57	\$3.57	\$3.57	\$3.57	\$3.57	\$3.57	\$3.57
6+	\$3.78	\$3.78	\$3.78	\$3.78	\$3.78	\$3.78	\$3.78	\$3.78	\$3.78	\$3.78
1+	\$4.20	\$4.20	\$4.20	\$4.20	\$4.20	\$4.20	\$4.20	\$4.20	\$4.20	\$4.20

mm	2.3	2.5	2.7
12+	\$3.57	\$7.76	\$7.76
6+	\$3.78	\$8.42	\$8.42
1+	\$4.20	\$9.35	\$9.35



**Kit Order # 77-2140**

12-Piece Bur Kit  
 (1 each) .60mm–2.5mm

12+	\$9.44
6+	\$9.99
1+	\$11.10



PANTHER® CONE SQUARE CROSS-CUT BURS, FIG. #23

**Order # 77-10015**

Material Tungsten Vanadium Steel  
 Head Shape Cone  
 Shank Size 3/32"  
 Sold in packs of 6

mm	0.6	0.7	0.8	0.9	1.0	1.1	1.2	1.3	1.4	1.5
12+	\$3.57	\$3.57	\$3.57	\$3.57	\$3.57	\$3.57	\$3.57	\$3.57	\$3.57	\$3.57
6+	\$3.78	\$3.78	\$3.78	\$3.78	\$3.78	\$3.78	\$3.78	\$3.78	\$3.78	\$3.78
1+	\$4.20	\$4.20	\$4.20	\$4.20	\$4.20	\$4.20	\$4.20	\$4.20	\$4.20	\$4.20

mm	1.6	1.8	2.1	2.3	2.5
12+	\$4.08	\$4.08	\$4.08	\$4.08	\$7.68
6+	\$4.32	\$4.32	\$4.32	\$4.32	\$8.33
1+	\$4.80	\$4.80	\$4.80	\$4.80	\$9.25



**Kit Order # 77-2240**

12-Piece Bur Kit  
 (1 each) .60mm–2.1mm

12+	\$8.67
6+	\$9.18
1+	\$10.20



PANTHER® ROUND BURS, FIG. #H71

**Order # 77-10016**

Material Tungsten Carbide Steel  
 Head Shape Ball  
 Shank Size 3/32"  
 Sold in packs of 6

mm	0.3	0.4	0.5	0.6	0.7	0.8	0.9	1.0	1.1	1.3
12+	\$19.71	\$19.71	\$19.71	\$19.71	\$19.71	\$19.71	\$19.71	\$19.71	\$19.71	\$19.71
6+	\$21.38	\$21.38	\$21.38	\$21.38	\$21.38	\$21.38	\$21.38	\$21.38	\$21.38	\$21.38
1+	\$23.75	\$23.75	\$23.75	\$23.75	\$23.75	\$23.75	\$23.75	\$23.75	\$23.75	\$23.75

mm	1.4	1.5	1.6	1.7	1.8	1.9	2.0	2.1	2.2	2.3
12+	\$19.71	\$19.71	\$19.71	\$19.71	\$19.71	\$19.71	\$19.71	\$19.71	\$19.71	\$19.71
6+	\$21.38	\$21.38	\$21.38	\$21.38	\$21.38	\$21.38	\$21.38	\$21.38	\$21.38	\$21.38
1+	\$23.75	\$23.75	\$23.75	\$23.75	\$23.75	\$23.75	\$23.75	\$23.75	\$23.75	\$23.75



PANTHER® TAPERED ROUND END BURS, FIG. H23RS

**Order # 77-10018**

Material Tungsten Carbide Steel  
 Head Shape Cylinder  
 Shank Size 3/32"  
 Sold in packs of 6

mm	0.8	0.9	1.0
12+	\$19.71	\$19.71	\$19.71
6+	\$21.38	\$21.38	\$21.38
1+	\$23.75	\$23.75	\$23.75



PANTHER® CONE ROUND BURS, FIG. #H23R

**Order # 77-10019**

Material Tungsten Carbide Steel  
 Head Shape Cone  
 Shank Size 3/32"  
 Sold in packs of 6

mm	1.0	1.2	1.6
12+	\$19.71	\$19.71	\$19.71
6+	\$21.38	\$21.38	\$21.38
1+	\$23.75	\$23.75	\$23.75



**Order # 77-10020**

Material Tungsten Carbide Steel  
 Head Shape Cylinder  
 Shank Size 3/32"  
 Sold Each

mm	0.9	1.2	1.4
12+	\$18.72	\$18.72	\$18.72
6+	\$20.30	\$20.30	\$20.30
1+	\$22.55	\$22.55	\$22.55



PANTHER® CYLINDER LONG BURS, FIG. #21L

**Order # 77-10023**

Material Tungsten Carbide Steel  
 Head Shape Round  
 Shank Size 3/32"  
 Sold in packs of 6

mm	0.9	1.0
12+	\$33.49	\$33.49
6+	\$36.32	\$36.32
1+	\$40.35	\$40.35



PANTHER® CONE ROUND CROSS-CUT EXTRA FINE BURS, FIG. H33 FR5

**Order # 77-10024**

Material Tungsten Carbide Steel  
 Head Shape Cone  
 Shank Size 3/32"  
 Sold in packs of 6

mm	0.9	1.2
12+	\$19.71	\$19.71
6+	\$21.38	\$21.38
1+	\$23.75	\$23.75



PANTHER® CONE SQUARE BURS, FIG. #H23

**Order # 77-10022**

Material Tungsten Carbide Steel  
 Head Shape Cone  
 Shank Size 3/32"  
 Sold in packs of 6

mm	1.0	1.2	1.6
12+	\$18.72	\$18.72	\$18.72
6+	\$20.30	\$20.30	\$20.30
1+	\$22.55	\$22.55	\$22.55



PANTHER® CONE SQUARE BURS, FIG. #H23L





**Order # 77-10026**

Material Tungsten Carbide Steel  
 Head Shape Cylinder  
 Shank Size 3/32"  
 Sold in packs of 6

mm	0.8	1.0	1.2	1.4	1.6	1.8
12+	\$18.72	\$18.72	\$18.72	\$18.72	\$18.72	\$18.72
6+	\$20.30	\$20.30	\$20.30	\$20.30	\$20.30	\$20.30
1+	\$22.55	\$22.55	\$22.55	\$22.55	\$22.55	\$22.55



PANTHER® CYLINDER PLAIN BURS,  
FIG. #H21



**Order # 77-10025**

Material Tungsten Carbide Steel  
 Head Shape Cone  
 Shank Size 3/32"  
 Sold in packs of 6

mm	0.9	1.0	1.2	1.4	1.6	2.1
12+	\$18.72	\$18.72	\$18.72	\$18.72	\$18.72	\$18.72
6+	\$20.30	\$20.30	\$20.30	\$20.30	\$20.30	\$20.30
1+	\$22.55	\$22.55	\$22.55	\$22.55	\$22.55	\$22.55



PANTHER® CONE SQUARE  
CROSS-CUT BURS, FIG. #H33



**Order # 77-10027**

Material Tungsten Carbide Steel  
 Head Shape Cone  
 Shank Size 3/32"  
 Sold in packs of 6

mm	0.9	1.0
12+	\$28.59	\$28.59
6+	\$31.01	\$31.01
1+	\$34.45	\$34.45



PANTHER® CONE ROUND  
CROSS-CUT BURS, FIG.  
#H23RSE



**Order # 77-10030**

Material Tungsten Carbide Steel  
 Head Shape Cone  
 Shank Size 3/32"  
 Sold in packs of 6

mm	0.9	1.0	1.2	1.6	2.1
12+	\$18.72	\$18.72	\$18.72	\$18.72	\$18.72
6+	\$20.30	\$20.30	\$20.30	\$20.30	\$20.30
1+	\$22.55	\$22.55	\$22.55	\$22.55	\$22.55



PANTHER® CONE SQUARE  
CROSS-CUT LONG BURS,  
FIG. #H33L



Tools shown not included

**ROTATING TOOL HOLDER**

Rotating bur holder organizes 114 burs with 3/32" shank. It also features a handy 2 3/4" width x 3" depth cup at the top for storing bench tools.

Order #	W×L	12+	6+	1+
19-9273	7"×4"	\$16.10	\$16.80	\$17.50



**Order # 77-10031**

Material Tungsten Vanadium Steel  
 Head Shape Cup  
 Shank Size 3/32"  
 Sold in packs of 6

mm	0.8	0.9	1.0	1.1	1.2	1.3	1.4	1.5	1.6	1.7	1.8	1.9
12+	\$7.78	\$7.78	\$7.78	\$7.78	\$7.78	\$7.78	\$7.78	\$7.78	\$7.78	\$7.78	\$7.78	\$7.78
6+	\$8.24	\$8.24	\$8.24	\$8.24	\$8.24	\$8.24	\$8.24	\$8.24	\$8.24	\$8.24	\$8.24	\$8.24
1+	\$9.15	\$9.15	\$9.15	\$9.15	\$9.15	\$9.15	\$9.15	\$9.15	\$9.15	\$9.15	\$9.15	\$9.15



PANTHER® CUP BURS, FIG. #77B

mm	2.0	2.1	2.3	2.5	2.7	2.9	3.0	3.5	4.0	4.5	5.0
12+	\$7.78	\$7.78	\$7.78	\$13.86	\$13.86	\$13.86	\$16.19	\$16.19	\$24.27	\$24.27	\$24.27
6+	\$8.24	\$8.24	\$8.24	\$15.03	\$15.03	\$15.03	\$17.15	\$17.15	\$25.70	\$25.70	\$25.70
1+	\$9.15	\$9.15	\$9.15	\$16.70	\$16.70	\$16.70	\$19.05	\$19.05	\$28.55	\$28.55	\$28.55

**Order # 77-10032**

Material Tungsten Vanadium Steel  
 Head Shape Cup  
 Shank Size 3/32"  
 Sold in packs of 6

mm	0.8	0.9	1.0	1.1	1.2	1.3	1.4	1.5	1.6	1.7
12+	\$11.39	\$11.39	\$11.39	\$11.39	\$11.39	\$11.39	\$11.39	\$11.39	\$11.39	\$11.39
6+	\$12.06	\$12.06	\$12.06	\$12.06	\$12.06	\$12.06	\$12.06	\$12.06	\$12.06	\$12.06
1+	\$13.40	\$13.40	\$13.40	\$13.40	\$13.40	\$13.40	\$13.40	\$13.40	\$13.40	\$13.40

mm	1.8	2.1	2.3
12+	\$11.39	\$11.39	\$11.39
6+	\$12.06	\$12.06	\$12.06
1+	\$13.40	\$13.40	\$13.40



PANTHER® SPECIAL CUP BURS, FIG.  
#256A

**Order # 77-10033**

Material Tungsten Vanadium Steel  
 Head Shape Cup  
 Shank Size 3/32"  
 Sold in packs of 6

mm	0.8	1.0	1.2	1.4	1.6	1.8
12+	\$11.39	\$11.39	\$11.39	\$11.39	\$11.39	\$11.39
6+	\$12.06	\$12.06	\$12.06	\$12.06	\$12.06	\$12.06
1+	\$13.40	\$13.40	\$13.40	\$13.40	\$13.40	\$13.40



PANTHER SPECIAL CONICAL CUP  
BURS, FIG. #256S

**PANTHER® WAX AND PLASTIC CARVING BURS**

Coarse burs that will not clog with wax.

**Order # 77-10034**

Item	Grade	Width	12+	6+	1+
A	Very Coarse	1.8 mm	\$22.74	\$24.66	\$27.40
B	Very Coarse	2.3mm	\$22.74	\$24.66	\$27.40
C	Very Coarse	3.1mm	\$30.30	\$32.09	\$35.65
D	Very Coarse	5mm	\$37.40	\$39.60	\$44.00

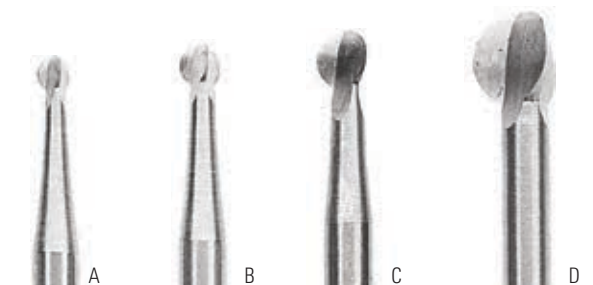

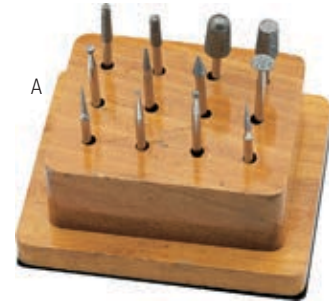

3/32" shank burs measuring 1 3/4" in length which are electroplated with diamond particles. Excellent for stone carving, clean up work, glass, ceramics and metals.

**DIAMOND BURS**

These long-wearing, high-quality diamond burs give you the hardness of diamond plate over steel to provide you with the uniform cutting edge you need to shape, grind, and finish with precision on a variety of materials. Round diamond point. Excellent for stone carving, clean-up work, glass, ceramics, and metals.

Item	Order #	Description	Grade	Length (mm)	OD (mm)	12+	6+	1+
A	19-5000	Set of 12				\$45.52	\$48.20	\$53.55
B	19-5002	Inverted Cone	Medium Fine	1.5	2.7	\$3.96	\$4.13	\$4.30
C	19-5006	Tapered Cylinder	Medium Fine	8.0	2.0	\$3.96	\$4.13	\$4.30
D	19-5008	Round Cone	Medium Fine	12.0	7.0	\$12.45	\$13.19	\$14.65
E	19-5009	Cylinder	Medium Fine	44.5	3.0	\$3.96	\$4.13	\$4.30
F	19-5010	Tapered Point	Medium Fine	10.0	1.5	\$3.96	\$4.13	\$4.30
G	19-5014	Point	Medium Fine	10.0	1.5	\$3.96	\$4.13	\$4.30
H	19-5015	Cone	Medium Fine	6.0	3.5	\$4.23	\$4.42	\$4.60
J	19-5017	Cylinder	Medium Fine	10.0	6.0	\$8.54	\$9.05	\$10.05
K	19-5023	Rounded Cylinder	Medium Fine	12.0	3.0	\$3.96	\$4.13	\$4.30
L	19-5027	Round	Coarse		1.0	\$3.96	\$4.13	\$4.30
M	19-5028	Round	Coarse		2.0	\$3.96	\$4.13	\$4.30
N	19-5029	Round	Coarse		3.0	\$4.69	\$4.90	\$5.10
P	19-5030	Round	Coarse		4.0	\$4.69	\$4.90	\$5.10
Q	19-5020	Round	Medium Fine		1.0	\$3.96	\$4.13	\$4.30
R	19-5021	Round	Medium Fine		2.0	\$3.96	\$4.13	\$4.30
S	19-5026	Round	Medium Fine		4.0	\$3.96	\$4.13	\$4.30
T	19-5031	Tapered Cylinder	Medium Fine	4.0	1.5	\$3.96	\$4.13	\$4.30



**DIAMOND DISC CUTTER**

Five diamond discs feature all medium grit and diamond electroplating on both sides for use when cutting or sanding. Kit includes a 1/8" mandrel and discs that will also fit perfectly on a 3/32" shank.

Order #	OD	Thickness	12+	6+	1+
11-8235	1 3/16"	0.84mm	\$12.76	\$14.36	\$15.95



**STULLER SELECT DIAMOND KNIFE® BURS**

Medium grit 3/32" shank.

Item	Order #	Description	OD	12+	6+	1+
A	19-6010	Assortment		\$35.24	\$36.77	\$38.30
B	19-6011	Knife-Edge	2.3mm	\$8.88	\$9.26	\$9.65
C	19-6012	Knife-Edge	5.0mm	\$13.75	\$14.35	\$14.95
D	19-6013	Knife-Edge	6.0mm	\$13.75	\$14.35	\$14.95

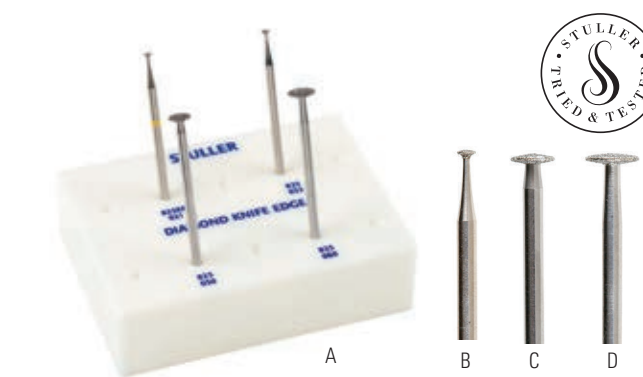

**STULLER SELECT FINE DIAMOND POINTS**

Fine grit 1/16" shank.

Item	Order #	Description	Length	OD	12+	6+	1+
U	19-6000	Set of 6			\$39.97	\$41.71	\$43.45
V	19-6001	Needle	8.0mm	1.4mm	\$7.08	\$7.39	\$7.70
W	19-6002	Flame	8.0mm	1.4mm	\$7.08	\$7.39	\$7.70
X	19-6003	Flame	3.5mm	1.6mm	\$7.08	\$7.39	\$7.70
Y	19-6004	Football	3.0mm	1.6mm	\$7.08	\$7.39	\$7.70
Z	19-6005	Football	5.0mm	2.3mm	\$7.08	\$7.39	\$7.70



**SPECIALTY DIAMOND DISC AND CUT-OFF WHEELS**

These specialty discs are designed to cut metals, shanks, prongs, fins, and stones. The discs are impregnated with diamonds, not just plated, so they will last longer. The wheels are set on 3/32" shanks. Made in Germany.

Item	Order #	Description	OD	Thickness	12+	6+	1+
E	11-8200	Serrated Disc/Saw	30mm	0.3mm	\$43.95	\$46.53	\$51.70
F	11-8210	Sintered Full Wheel	8mm	0.9mm	\$41.77	\$43.58	\$45.40
G	11-8211	Sintered Full Wheel	22mm	0.4mm	\$60.44	\$63.07	\$65.70
H	11-8212	Sintered Disc	20mm	0.17mm	\$56.44	\$58.90	\$61.35
J	11-8220	Mini-Flex	8mm	0.15mm	\$22.49	\$23.47	\$24.45
K	11-8230	Separating Wheel	22mm	0.15mm	\$23.89	\$25.29	\$28.10

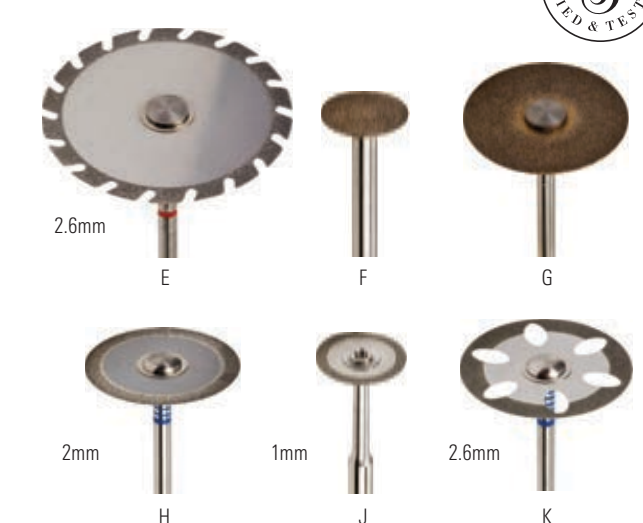

**DIAMOND COATED BUR KIT**

Order #	Description	12+	6+	1+
19-5001	20-Piece Assorted	\$6.60	\$7.16	\$7.95
19-5001	30-Piece Assorted (shown)	\$6.72	\$7.29	\$8.10



**MEDIUM WAX BURS**

Swiss-made, tungsten-vanadium steel burs are fluted to eliminate wax build-up. Can also be used for wood carving or plastic. Sizes and shapes may vary.

Order #	Description	12+	6+	1+
18-5089	Set of 12, Medium	\$26.39	\$28.62	\$31.80





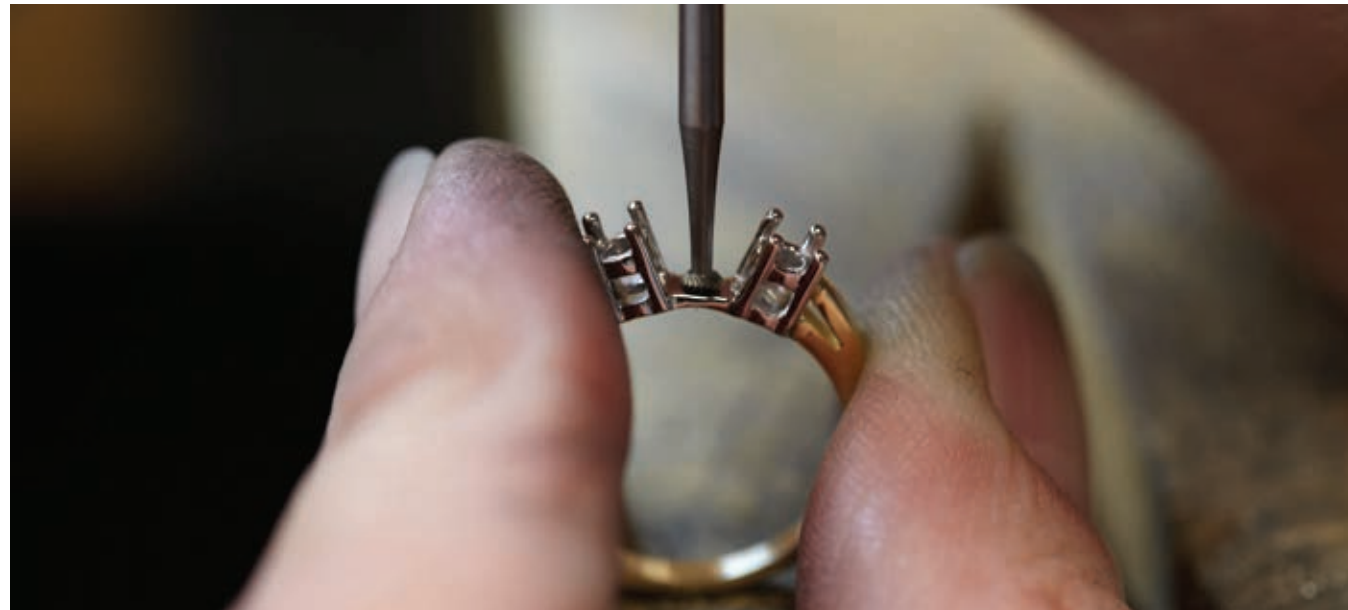

**DIAMOND FLY WHEELS**

A. Precision manufactured for bright-cutting gold and other precious metals, these are constructed with a high-grade, industrial diamond chip. Note: A diamond flywheel is a delicate, precision instrument. As it is an industry standard, we do not offer a warranty. No refunds or exchanges. Caution: Wear proper eye and face protection.

**Order # 11-09000**

Item	Degree	OD	12+	6+	1+
	90°	4.0mm	\$53.27	\$55.58	\$57.90
A	120°	4.0mm	\$53.27	\$55.58	\$57.90
	130°	4.0mm	\$53.27	\$55.58	\$57.90
	150°	4.0mm	\$53.27	\$55.58	\$57.90
	180°	4.0mm	\$53.27	\$55.58	\$57.90
	90°	3.0mm	\$53.27	\$55.58	\$57.90
	120°	3.0mm	\$53.27	\$55.58	\$57.90
	130°	3.0mm	\$53.27	\$55.58	\$57.90
	150°	3.0mm	\$53.27	\$55.58	\$57.90
	180°	3.0mm	\$53.27	\$55.58	\$57.90

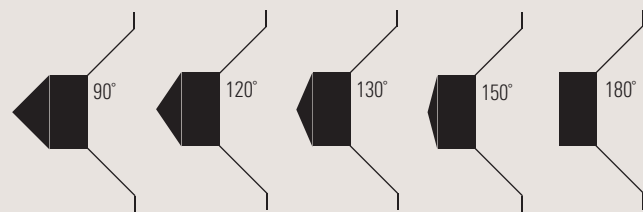

**DIAMOND FLY WHEELS**

The diamond flywheel requires little or no maintenance when used properly. There are a few considerations that should be identified to maximize the serviceability of the tool's life. First, the diamond flywheel is intended to run at high speeds in excess of 30,000 RPM. The 30,000 RPM is considered the minimum speed at which one of these wheels should be operated.

The most common arrangement for a flex shaft and handpiece combination is the R-series motor and #35 handpiece with the planetary drive system. Lubricating the diamond flywheel prior to and during cutting is not recommended. When using the diamond flywheel, it is necessary to allow it to come up to full speed before engaging with the surface to be cut. When cutting, very light pressure is all that is required. The wheel only needs to contact the surface to cut. If excessive force is applied while cutting, there is risk of knocking the diamond loose from the flywheel. If this happens, the flywheel is ruined, and no attempt should be made to glue the diamond back into the flywheel. Excessive pressure will also reduce the speed of the flywheel during operation, reducing its efficiency and making it more susceptible to damage.

**BUSCH® WAX CARVING BUR**

**Order # 18-10017**

OD	Shank Size	Per Pack	12+	6+	1+
1.8 mm	3/32"	Each	\$3.10	\$3.29	\$3.65
2.3 mm	3/32"	Each	\$3.10	\$3.29	\$3.65
3.1 mm	3/32"	Each	\$5.02	\$5.31	\$5.90
5.0 mm	3/32"	Each	\$6.04	\$6.39	\$7.10



**WOLF™ WAX CYLINDER BUR**

A. Made of high-speed steel, these are coarse-cut for rapid removal of wax. Features teeth on the end for milling and a longer cutting surface. Shorter shank length (25mm) reduces centrifugal wobble.

**WOLF™ WAX ROUND BUR**

B. Made of high-speed steel, these are coarse cut and ideal cut for controlled rapid removal of wax.

Item	Order #	OD	Shank Size	Per Pack	12+	6+	1+
<b>CYLINDER</b>							
A	20-1200	5-piece set			\$65.24	\$70.74	\$78.60
	20-1205	11.1mm	1/8"	Each	\$18.43	\$19.98	\$22.20
<b>ROUND</b>							
B	20-1206	5-piece set			\$59.52	\$62.11	\$64.70
C	20-1207	1.7mm	3/32"	Each	\$6.23	\$6.75	\$7.50
D	20-1208	3.5mm	3/32"	Each	\$8.22	\$8.91	\$9.90
E	20-1209	5mm	3/32"	Each	\$9.09	\$9.86	\$10.95
F	20-1210	7.2mm	3/32"	Each	\$10.54	\$11.43	\$12.70
G	20-1211	8.9mm	3/32"	Each	\$12.33	\$13.37	\$14.85



**GROBET USA® ROTARY FILES**

Made of high-speed steel, this cylinder shape fits easily into insides of rings. Not recommended for use exceeding 5,000 RPM.

Item	Order #	Grade	Length	OD	Shank	12+	6+	1+
H	33-6029	Standard	1 1/2"	1/2"	3/32"	\$26.78	\$28.35	\$31.50
J	33-6032	Fine	1 1/2"	1/2"	3/32"	\$38.23	\$39.89	\$41.55
	33-6350	Standard	1"	1/2"	1/8"	\$26.36	\$27.50	\$28.65
	33-6355	Fine	1 1/2"	1/2"	1/8"	\$38.23	\$39.89	\$41.55



**BUR STAND**

This bur stand fits on any microscope or any rod that has a diameter of 1 1/2". It can stay on your bench or be mounted on a shaft or rod. This stand has a detachable base that holds nine 3/32" burs. The cylinder is split and connected by a single hex screw (hex key supplied) that can be tightened to fit on the shaft of a microscope stand. The cylinder has 48 holes.

Order #	Description	12+	6+	1+
19-9280	Bench Bur Stand	\$32.05	\$33.93	\$37.70



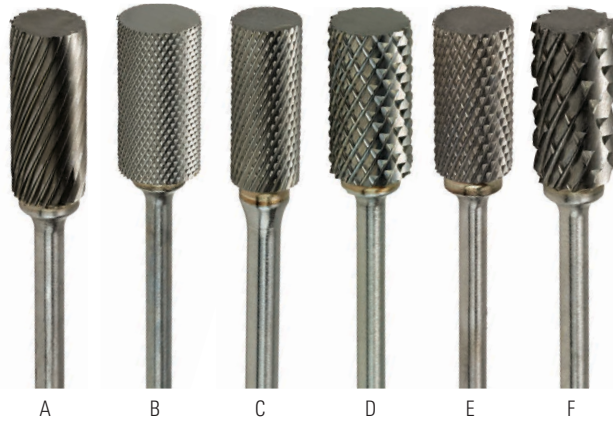

**INSIDE RING BURS**

Made of carbide steel for extra-long life, these cylinder burs are designed for fast deburring, smoothing, and finishing of inside-ring surfaces. Made in the USA.

Item	Order #	Grade	Length	OD	Shank	12+	6+	1+
SINGLE-CUT								
A	20-2924	Medium	3/8"	3/4"	1/8"	\$22.65	\$23.99	\$26.65
DOUBLE-CUT								
B	20-2920	Fine	3/4"	3/8"	1/8"	\$18.19	\$19.26	\$21.40
C	20-2922	Fine	5/8"	1/4"	1/8"	\$16.58	\$17.55	\$19.50
D	20-2930	Fine	1/2"	1/4"	3/32"	\$11.99	\$12.69	\$14.10
E	20-2932	Extra Fine	1/2"	1/4"	3/32"	\$11.99	\$12.69	\$14.10
F	20-2934	Extra Coarse	1/2"	1/4"	3/32"	\$11.99	\$12.69	\$14.10



**CARBIDE CYLINDER BURS**

Cylinder Length: 1/2"      Shank Length: 1"  
Cylinder Diameter: 1/4"      Total Length: 1 1/2"

Item	Order #	Grade	12+	6+	1+
G	20-2820	Coarse	\$9.60	\$10.80	\$12.00
H	20-2821	Medium	\$9.60	\$10.80	\$12.00
J	20-2822	Fine	\$9.60	\$10.80	\$12.00
K	20-2823	Extra Coarse	\$9.60	\$10.80	\$12.00



**CUTTERS**

Stuller is proud to offer the highest quality milling cutters on the market. These high precision cutters are available in the definitive shapes and sizes used by CAD/CAM operators around the world.

Item	Order #	Description	Color	Length	OD	1+
L	39-1830	Pyramid	Light Blue	1 1/2"	.004"	\$110.00
M	39-1831	Helical Pyramid	Dark Blue	1 1/2"	.004"	\$110.00
N	39-1832	Double Flute	Black	1 1/2"	.4"	\$82.50
P	39-1833	Single Flute	Yellow	1 1/2"	.47"	\$82.50



**BUR CADDY**

The hexagon rotating caddy is eight inches high with a removable top. This is a great tool to organize your burs and small tools for easy access. There are 288 holes for burs and tools along with two three-inch magnetic strips to keep your files and other hand tools close. The top offers 11mm in diameter holes for extra tool storage. With the rotating caddy, every tool it holds is visible and easy to access.

Item	Order #	WxLxH	12+	6+	1+
A	19-9276	6"x6"x8"	\$33.82	\$36.68	\$40.75



Tools sold separately

**HANDY BUR BOX**

This handy box is designed for storing burs at the bench. Makes finding the right size bur easy and convenient. The handy bur box slips into your center bench drawer. Leave the burs in their original plastic packaging for quick retrieval. Made of hardwood with removable dividers.

Item	Order #	WxLxH	12+	6+	1+
B	18-0509	5 7/8"x1 1/2"x1 1/2"	\$7.82	\$8.16	\$8.50



**HANDY BUR BLOCK**

Cured, hardwood block with 88 holes that are 1/8" in diameter to accommodate either 1/8" or 3/32" shanks. Block is slanted and also features stay-put rubber pads on the bottom to prevent sliding. Will hold burs, needle files, beaders, and mini brushes.

Item	Order #	WxL	12+	6+	1+
C	19-9260	4 1/2"x6"	\$11.68	\$12.19	\$12.70



**BUR STAND PLUS**

This bur stand is solid smooth wood painted black for an easy to see tool holder. This stand has a magnetic side for easy grab and go. There are 88 holes (eight rows with 11 drilled 4mm holes in each). There is also a long groove for holding your unmounted wheels and other tools. This stand also has felt cushions on the bottom to prevent scratching on your bench.

Item	Order #	WxLxH	12+	6+	1+
D	19-9277	5 1/4"x6 1/2"x2"	\$18.59	\$20.16	\$22.40



**MAGNETIC BUR STAND**

Incorporates a strong magnet to keep your burs, mounted points, brushes, and drills organized and readily at hand. Constructed from high-impact plastic, the Magnetic Bur Stand measures 2 1/4" diameter x 2 1/4" high and holds up to 40 burs or other rotary instruments.

Item	Order #	Height	12+	6+	1+
E	19-9247	2 1/4"	\$12.42	\$12.96	\$13.50







Sturdy wooden bur boxes work well for burs with 3/32" shanks or other mounted tools. Burs sold separately.

**24-HOLE WOOD BUR BOX**

Item	Order #	Number of Holes	12+	6+	1+
A	18-0504	24	\$6.25	\$6.62	\$7.35

**36-HOLE WOOD BUR BOX**

Item	Order #	Number of Holes	12+	6+	1+
B	18-0505	36	\$6.84	\$7.25	\$8.05

**72-HOLE WOOD BUR BOX**

Item	Order #	Number of Holes	12+	6+	1+
C	18-0506	72	\$9.86	\$10.44	\$11.60

**100-HOLE WOOD BUR BOX**

Item	Order #	Number of Holes	12+	6+	1+
D	18-0507	100	\$10.46	\$11.07	\$12.30

**ROTATING BUR HOLDER**

Conveniently stores and organizes all sizes of burs. Holds 69 burs with 3/32" or 1/8" shanks and 45 burs with 1/16" shank. Made in the USA.

Item	Order #	WxL	12+	6+	1+
A	19-9272	7"x4"	\$16.10	\$16.80	\$17.50

**BUR ORGANIZER**

Lazy Susan type of bur organizer. Holds up to 150 burs with 3/32" shank.

Item	Order #	WxL	12+	6+	1+
B	19-9270	7"x4"	\$12.33	\$13.37	\$14.85

**ROTATING TOOL HOLDER**

Rotating bur holder organizes 114 burs with 3/32" shank. It also features a handy 2 3/4" width x 3" depth cup at the top for storing bench tools.

Item	Order #	WxL	12+	6+	1+
C	19-9273	7"x4"	\$16.10	\$16.80	\$17.50

**PLASTIC BUR HOLDER**

Square plastic stand with clear cover for storing 34 accessories with 3/32" shank and 18 accessories with 1/8" shank.

Item	Order #	WxL	12+	6+	1+
D	19-9252	2 1/2"x2 1/2"	\$4.14	\$4.32	\$4.50

**PLASTIC BUR STAND**

Holds burs with 3/32" shank securely in place.

Item	Order #	WxHxD	12+	6+	1+
E	19-9250	5"x1"x3"	\$5.74	\$6.08	\$6.75

**MATT GOLD COLLECTOR**

Traps gold and other precious metals for easy retrieval. Provides convenient precious metal collection while enabling you to keep arms and hands in a natural working position. Protects your eyes and skin from dust and flying particles. Optically clear Plexiglass® shield allows for glare-free viewing. Completely portable, lightweight, and strong. Plexiglass shield easily removes for cleaning and scrap collection.

Item	Order #	WxLxH	12+	6+	1+
F	21-0960	7"x7"x9"	\$85.51	\$90.54	\$100.60

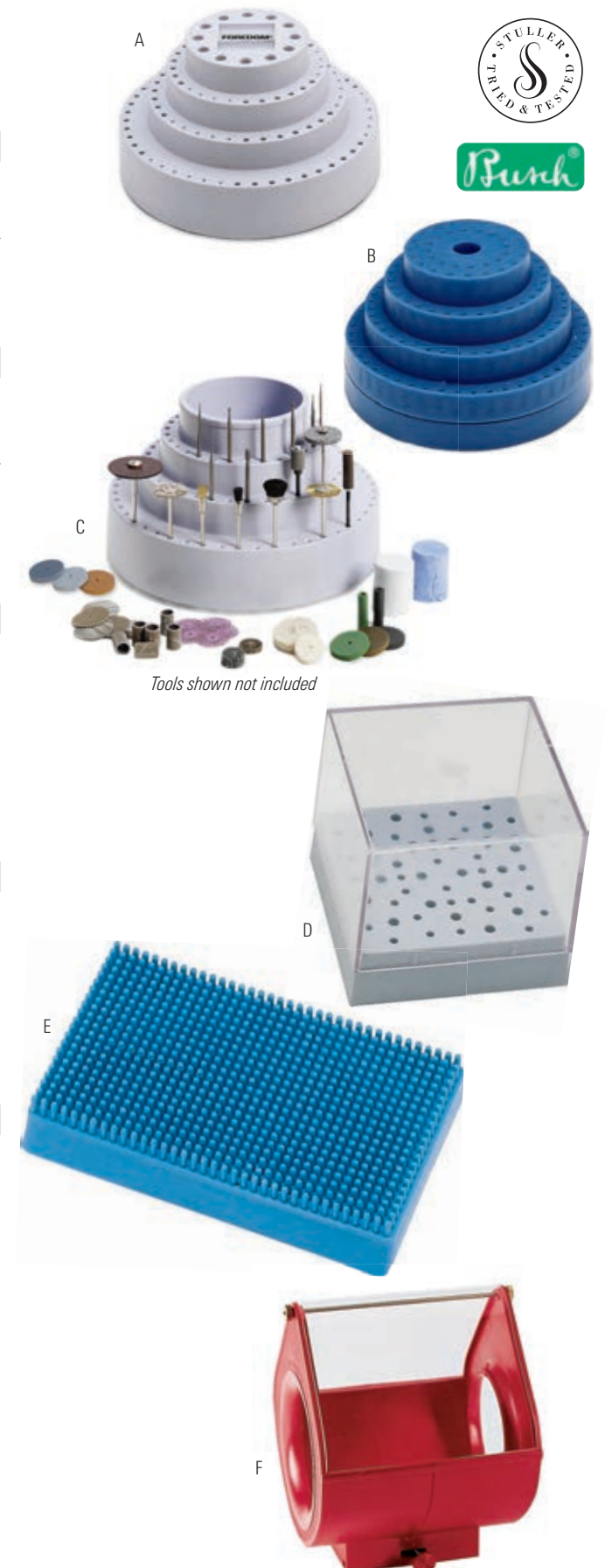

# CASTING

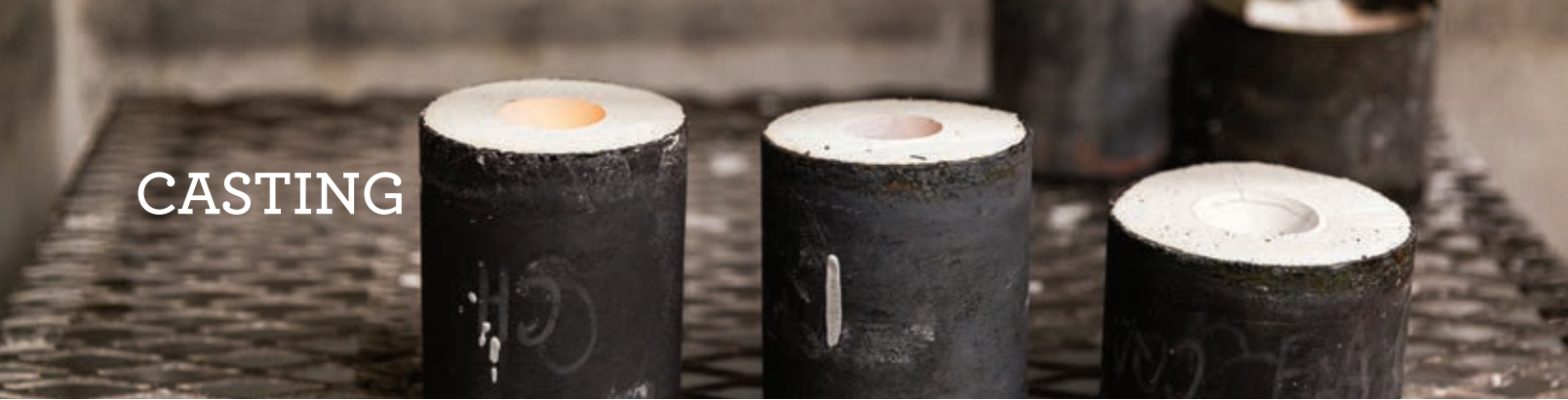

Casting

## STULLER'S NEW LINE OF 3D PRINTERS

ASIGA'S PICO2™, Pico2HD™, and PRO2™

We're excited to announce the debut of Asiga's impressive desktop devices in our line. Asiga is a leader in the rapidly expanding market for 3D printers, and we're extremely impressed by their track record of technological innovations for the jewelry industry. Check out a few of the features that stand out.

Designed specifically to print detailed, intricate parts with an utterly smooth surface finish, the Pico2 and Pico2HD are compact but with roomy build envelopes that can handle significant production demands. Intuitive to operate thanks to a touch-screen display, easy calibration, and Wi-Fi connectivity, Asiga devices will help you take your workflow to the next level.

**PICO2 (24-1125, \$8,990.00) Leading the Way in Desktop Revolution**  
Realize your CAD designs quickly with the PICO2, the industry-leading desktop printer for direct production of jewelry casting patterns and master models.

- Print up to 20 parts in less than one hour
- Dimensions: 10.23"×14.96"×14.5"
- Maximum Build Size: 2.52"×1.57"×2.95"

**PICO2HD (24-1126, \$11,990.00) The World's Smallest HD 3D Printer**  
The PICO2HD delivers extraordinary resolution and build capacity to your desktop. It is ideal for the production of jewelry casting patterns and master models with a build envelope large enough to print bangles and larger items.

- Print up to 30 parts in less than one hour
- Dimensions: 10.23"×14.96"×19.88"
- Maximum Build Size: 2.79"×1.57"×2.95"

**PRO2 (24-1127, \$24,990.00)**  
The Freeform PRO2™ Series 50 is a professional 3D printer for direct manufacturing of jewelry casting patterns and master models. Being the largest system in our range, the PRO2 Series 50 is ideal for companies requiring a higher output.

- Print up to 100 parts in less than four hours
- Technical Data: Pixel Size X, Y: 50m
- Dimensions: 17.72"×19.29"×31.5"
- Maximum Build Size: 96mm×54mm×200mm

Shop the selection of offered products at [Stuller.com/Asiga](http://Stuller.com/Asiga).

## ASIGA® 3D PRINTERS

Resolution: Variable in 1µm.  
File Inputs: STL, SLC, STM.  
Software: Composer Included (Lifetime software updated included).  
Network Compatibility: Wi-Fi and Ethernet.  
Industry Sectors: Jewelry Manufacturing.  
System Weight 14Kg.  
Power: 12VDC 10A

Item	Order #	Description	1+
A	24-1126	Asiga® Pico2 HD™	\$11,990.00
B	24-1127	Asiga® Pro2™ 50 Series	\$24,990.00
C	24-1125	Asiga® Pico2™ 50	\$8,990.00
	24-1128	Asiga® PICO2™ 39 Series	\$6,990.00

- High-Power UV LED** For long-term reliability
- Quick Release** Fast material change over
- Single Point Calibration** Calibrate in under 30 seconds
- Wi-Fi Enabled** Connect wirelessly
- Touch-Screen Display** For greater user convenience
- SAS Technology** Minimum supports, maximum speed
- High Impact Hood** UV blocking with excellent clarity
- Open Material System** Use any suitable 3rd party material
- Internal Radiometer** Automatic LED power calibration
- Lifetime Technical Support** Free and unlimited



## ASIGA® PICO2™, PICO2HD™, AND PRO2™ BUILD TRAY

Item	Order #	Description	12+	6+	1+
A	24-1135	Asiga® Pico2™ and Pico2™ HD Build Tray	\$138.00	\$144.00	\$150.00
	24-1136	Asiga® Pro2™ Build Tray	\$161.00	\$168.00	\$175.00



A

## ASIGA® SUPERWAX RESIN

Only compatible with Asiga® PICO2™ and PICO2 HD™. Direct casting WAX material for use with platinum and gold alloys

Item	Order #	Description	Container Volume	12+	6+	1+
B	24-1129	Asiga® Superwax Resin	500mL	\$322.00	\$336.00	\$350.00
	24-1130	Asiga® Superwax Resin	1L	\$414.00	\$432.00	\$450.00



B

## ASIGA® SUPERCASST RESIN

Resin is compatible with all Asiga® 3D Printers. Direct casting resin material for use with gold alloys.

Item	Order #	Description	Container Volume	12+	6+	1+
C	24-1131	Asiga® Supercast Resin	500mL	\$322.00	\$336.00	\$350.00
	24-1137	Asiga® SuperCAST V3	500mL	\$322.00	\$336.00	\$350.00
	24-1132	Asiga® Supercast Resin	1L	\$414.00	\$432.00	\$450.00



C

## ASIGA® FUSIONGRAY

Resin is compatible with all Asiga® 3D Printers. Vulcanized rubber molds and RTV

Item	Order #	Description	Container Volume	12+	6+	1+
D	24-1133	Asiga® Fusiongray	500mL	\$322.00	\$336.00	\$350.00
	24-1134	Asiga® Fusiongray	1L	\$414.00	\$432.00	\$450.00



D

## RADIDPOL SET FOR POLISHING

The Hatho RapidPol set comes with everything you need to polish grow lines on resins that are created during the rapid prototype process. Doing this will help you to achieve a better casting.

Order #	Description	1+
11-7102	RapidPol Set for Polishing	\$82.40



Casting



## EasyCast 12

The EasyCast 12 is an induction casting machine designed to increase your productivity with a high degree of control. It casts all metals, precious and non-precious, with an automatic frequency setting, so you can enjoy a fast melting process. The heating generator utilizes the latest in high efficient technology. This reliable modular system has low maintenance requirements and low energy consumption.

### FEATURES

- Advanced digital control panel with status and diagnostics messages
- Centrifugal injection casting with pneumatic movement for fast coil decent
- Integral water cooling system with pressure and water temperature control
- Centrifugal arm balancing with adjustable counterweight
- Infrared temperature reader with automatic or manual working cycle

- Auto locking of the chamber lid during centrifugal phase for maximum safety
- Melting power regulation
- DC motor with reduction gear: adjustable acceleration from 0.1 to 1 second
- Max rotating speed-500 turns/minute rotation timeout pre-set at 40 seconds
- Normal atmospheric operation
- Internal vacuum pump (EC-12)
- Insert (Argon) gas circuit included (EC-12)
- Set up with 44mm diameter crucibles for jewelry casting (EC-12)

### BENEFITS

- Improved energy efficiency
- Higher degree of control
- Increased repeatability
- Low maintenance requirements
- Increased productivity

Order #	Description	WxLxH	1+
22-2160	EasyCast12	19"×26"×41"	\$16,650.00

Absorbed Power kW (max)	3.0
AC Line Volts (50/60Hz)	230±10%
Line Phases	1
Crucible Capacity	150g Pt, 150g Au, 80g Ag
Flask Size (max)	3"×3"
Max Melting (T°)	2000 C°
IR Temperature Reader	Included
Vacuum Pump	Included
Weight	265 lbs (120 kg)
Dimensions WxLxH	19.2"×26"×41" (49×66×105 cm)



## CS1 Digital Control Casting Machine

The CS1 Digital Control Casting Machine is the next step for casting made easy. This casting machine has a overhaul of features to give you the ultimate casting experience.

### FEATURES

- New melting circuit
- New control board
- New temperature reader
- New high-tech Thermo-Regulator
- Metal emissivity regulation
- Auto-diagnosis
- 10 memories
- Vacuum-Argon washing cycle
- Automatic vacuum release

### BENEFITS

- Better power regulation
- Totally microprocessor controlled
- More accurate temperature reading
- Better heating cycle control
- Easier to find the metal melting point
- 10 error messages
- Nine parameter per program
- For casting with stone
- No more valve on the top of the lid

This system was designed primarily for the casting of platinum but can also be used for casting all precious metal alloys and industrial alloys. The CS1 is available with a 7.5kW melting circuit and can be fitted with temperature controls, vacuum systems, and inert gas inlets. The crucible can handle about 350 grams of platinum, 800 grams of pure gold, or 250 grams of stainless steel.

Order #	Description	WxLxH	1+
22-2200	CS1 Digital Casting Machine	30"×25"×40"	\$36,950.00

Absorbed Power kW (max)	7.5
Medium Frequency Melting Circuit	30-60 KHz
Crucible Capacity	350g Pt
Flask Size (max)	4"×4.75"
Power Supply	220/230 V Three Phase - 380 V Three Phase
Vacuum Pump	Included
Weight	380 lbs (172 kg)
Dimensions WxLxH	30"×25"×40" (76×167×102 cm)



## SuperCast 12

SuperCast 12 is a casting system in a class by itself. With development of the patented RCS (Rotating Coil System), the user no longer has to raise or lower the induction coil. With the RCS, the induction coil is integrated into the centrifugal arm, thus allowing the material being cast to continue stay under heat as it is being shot into the flask. Being able to keep the metal under heat during the centrifuge process leads to denser castings with less porosity. The Supercast is totally microprocessor controlled. With decreased coil maintenance you can spend more time focusing on the actual casting of items.

### FEATURES

- Patented RCS system (Rotating Coil System)
- Totally microprocessor controlled
- 10 memories (complete working programs with up to nine parameters/program)
- 4kW induction melting circuit

- Fiber optic temperature control with ETC calibration
- 220V, single-phase power requirement
- Excellent for gold alloy
- Ideal for chrome-cobalt and nickel-chrome
- Exceptional for platinum and titanium
- Vacuum pump system
- Inert gas dispensing system
- Internal water circulator

### BENEFITS

- Decreased coil maintenance
- Eliminates induction coil movement
- Metal is still heated during rotation
- Extremely compact metal casting



256 lbs

Order #	Description	1+
22-2190	SuperCast J4	\$28,850.00

<b>Power</b>	4 kW
<b>Frequency</b>	65/90 kHz
<b>Consumption</b>	AC 220V, Single phase, 50/60 Hz
<b>Crucible Capacity</b>	200g Pt
<b>Flask Size (max)</b>	3"×3"
<b>Max Melting (T°)</b>	2000 C°
<b>Temperature Reader</b>	Optional
<b>Cooling System</b>	Built-in or external closed circuit system
<b>Vacuum Pump</b>	Included
<b>Rotation Time</b>	Preset at 45 seconds, automatic rotation stop
<b>Casting Time</b>	Adjustable
<b>Weight</b>	256 lbs (130 kg)
<b>Dimensions W×L×H</b>	27"×22"×40" (67×22×100 cm)

### RDO WATER RECIRCULATOR

RDO's closed loop water cooling systems range from three to 25 gallon capacity. Depending on the induction system and application, the appropriate system will be recommended for optimal performance. Installing the proper cooling system will extend the life of the induction power supply, reduce maintenance costs as well as downtime. Our closed loop cooling system has stainless steel construction which eliminates coolant contamination due to electrolysis or chemical reactions. They are plumbed with copper tubing and a reinforced hose. No external plumbing is required for our closed loop water systems. Water level float gauge and filler caps are combined in a single-unit multi purpose sight glass which enables operator to observe return water from a distance. These units are equipped with thermal overload. RDO also supplies and sells Lubricist water treatment solution for inhibiting algae growth.

#### Order # 14-1520

Item	Description	L×W×H	1+
A	Model 3 Water Recirculator	23"×11"×14 ¾"	\$975.00
	Model 10 Water Recirculator	23"×11"×20"	\$1,100.00



### EASYMELT AND EASYMELT HT

The EasyMelt is a robust industrial design for low or high-volume melting and is micro-processor controlled. This is a compact bench top system for your everyday use. For your convenience, it has fast melting times with a powerful 2.5kW melting circuit.

### FEATURES

- Robust industrial design for low or high-volume melting
- Powerful 2.5 kW melting circuit for fast melt times
- Micro-processor controlled
- Operates on 220V, one-phase; 50/60 Hz
- Thermocouple temperature control
- 10-15 minute melt times for up to two kg of gold (EasyMelt)
- Under five minute melt time for up to 250 grams of platinum (EasyMelt HT)
- Optional water cooling system

### BENEFITS

- Compact bench top system
- Extremely fast and efficient melting of small metal quantities
- Economical and practical for jewelry applications
- Greater degree of control over melting processes

Order #	Description	1+
22-2180	EasyMelt	\$5,450.00
22-2170	EasyMelt HT	\$5,950.00

### EasyMelt Specifications

<b>Power Supply</b>	220V, One-Phase; 50/60 Hz
<b>Output Power</b>	2.5 kW
<b>Crucible Capacity</b>	2 kg gold (18kt weight) 1.2 kg silver
<b>Water Cooling</b>	System requires water cooling
<b>Weight</b>	20 lbs (9 kg)
<b>Dimensions W×L×H</b>	14"×18"×7" (355×457×178 mm)

LED display for power regulation, exact timing, and precise temperature control.



20 lbs

### EasyMelt HT Specifications

<b>Power Supply</b>	220V, One-Phase; 50/60 Hz
<b>Output Power</b>	2.5 kW
<b>Crucible Capacity</b>	250 grams platinum 150 grams gold
<b>Water Cooling</b>	System requires water cooling
<b>Weight</b>	20 lbs (9 kg)
<b>Dimensions W×L×H</b>	14"×18"×7" (355×457×178 mm)





20" W x 20" L x 12" H

**NEYCRAFT® SPINCASTER**

This Neycraft® Spincaster comes with a self-contained well and is mounted on a base. The unit comes with one silica crucible with a capacity of nine ounces of gold and five ounces of silver. The unit has an easy balancing system with lock. Also comes with a 3" x 3" stainless steel solid-wall flask with three-inch base, 2" x 2½" solid flask with a base, one pair of tongs, and a universal cradle for the flask.

Item	Order #	Description	12+	6+	1+
A	22-3600	Centrifugal Casting Machine	—	—	\$941.84
B	22-3604	Complete Slide Assembly	—	—	\$188.90
C	22-3602	Replacement Spring	\$86.36	\$91.44	\$101.60
D	22-3603	Counter Balance Weight	\$35.83	\$37.94	\$42.15
E	22-4620	Replacement Crucible	\$20.88	\$21.79	\$22.70

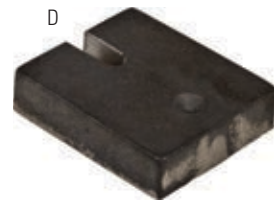
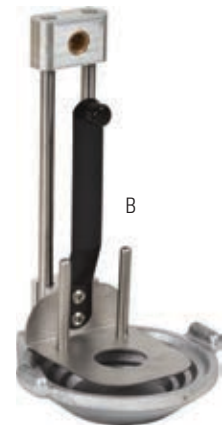

**CENTRIFUGAL FLOOR MODEL CASTING MACHINE**

The unit that pioneered the centrifugal casting technology in the jewelry industry. "Broken" arm design allows maximum metal flow into flask. Equipped with an automatic digital count down timer and adjustable speed.

Order #	Description	1+
22-1304	Centrifugal Machine	\$6,343.15

**COMBINATION CASTING AND VACUUM INVESTING MACHINE**

Space-saving design incorporates both casting and investing in one unit. Heavy-duty design and fabrication with the strongest vacuum pump in the market, this vacuum storage tank enables instantaneous pull around casting flask and a foot pedal operated for hands-free use.

Item	Order #	Description	1+
A	22-1302	Combination Machine	\$16,153.85



**SUPER VAC VACUUM CASTING MACHINE**

Proven technology with proven results makes the Arbe Super Vac the choice for the professional caster. Heavy-duty design and fabrication with the strongest vacuum pump in the market, this vacuum storage tank enables instantaneous pull around casting flask and a foot pedal operated for hands-free use.

Item	Order #	Description	1+
B	22-1300	Casting Machine	\$10,769.25



**VACUUM INVESTMENT MACHINE**

This 20" x 20" spring-mounted investment table is simple to set up and operate. Its heavy-duty 12-gauge cabinet features a durable powder-coated finish and hinged front panel with latched access to vacuum pump. 15CFM/1HP Oil-Filled vacuum pump. Ball vise-controlled vacuum flow rate features extra thick internal rubber hosing.

Item	Order #	Description	1+
C	22-1301	Investment Machine	\$7,692.35





**MASTER-CAST WITH OIL-LESS VACUUM PUMP**

This new oil-less Master-Cast unit has a powerful 1/2 HP maintenance-free vacuum pump that produces 29.9" Hg of vacuum.

Item	Order #	Description	1+
A	22-1305	Oil-Less Master Cast unit	\$1,595.00



**STULLER VAC-U-CAST MASTER-CAST**

The Vac-U-Cast Master-Cast is an exceptional unit combining all the features with the added dimension of casting in a recessed vacuum chamber. Vacuum investing is accomplished under a 9" diameter x 8" high bell jar. The recessed vacuum chamber will accommodate perforated flasks as large as 5" diameter x 7" height or as small as 3 3/8" diameter x 4" height. A direct drive, two-stage pump and motor create a free air displacement of 85 liters per minute 3 CFM) producing a vacuum of 25 microns or better, exceeding the required 29.9 inches of mercury, in less than one minute. Motor 1/3HP 120V. (7 amp). One-year limited manufacturer's warranty. Made in the USA.

Item	Order #	Description	1+
B	22-1150	Vac-U-Cast Master-Cast	\$1,435.00

**REPLACEMENT PARTS FOR 22-1305, 22-1150 AND 22-1180**

Item	Order #	Description	Size	1+
C	22-1185	Bell Jar (2.8 lb)	9"x8"	\$116.75
D	21-7005	Perforated Flask (1.39 lb)	3 3/8"x4"	\$29.55
E	22-4727	Sprue Base (4.35 lb)	3 3/8"	\$4.60
F	21-4999	Adapt Plate Vacuum Hole (1 lb)		\$71.00
G	21-5001	Casting Silicone Seal	7"	\$16.15
H	21-5002	Investing Rubber Pad (Black) (1.5 lb)		\$16.35
J	21-5006	Flask Seal (4.8 oz)	2 1/2"	\$17.40
K	21-5003	Flask Seal (4.8 oz)	3 3/8"	\$15.40
L	21-5004	Flask Seal (4.8 oz)	4 1/2"	\$12.35
M	21-5005	Flask Seal (4.8 oz)	5"	\$12.25
N	22-1152	Plate Adaptor (1.51 lb)	3 3/8"	\$69.70
P	22-1153	Plate Adaptor (1.04 lb)	4"	\$74.45
Q	21-5000	Silicone Rubber Pad	5 1/2"	\$12.20
R	22-7911	Crucible	7 oz	\$14.40
S	22-7912	Handle		\$7.15
T	22-7910	Crucible with Handle		\$22.70

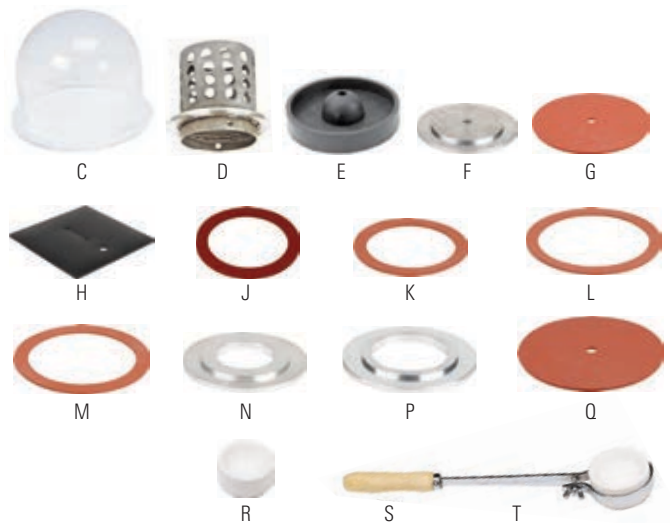

**VAC-U-CAST JUNIOR**

Compact, quality-built tabletop unit allows for vacuum investing and casting to be accomplished on the same table simply by changing rubber pads and operating two valves. Complete with 9" diameter x 8" height bell jar, crucible with handle, silicon casting pad, and 32-ounce vacuum pump oil. One-year limited manufacturer's warranty. Made in the USA.

Order #	Description	1+
22-1180	Vac-U-Cast Junior	\$860.00



**CENTRIFUGAL TABLETOP CASTING MACHINE**

The CAST/T is a compact centrifugal casting machine for the production of precision castings. The casting machine includes a 30 mm and 60mm casting flask, the necessary handling tools, wax disks, and investments. The casting machine also includes one 150-gram and one 250 gram crucible for a flame melt. The manufacturer highly recommends a propane/oxygen flame. The CAST/T can cast up to 450 grams of gold, platinum, silver, or other alloys in one mold. The CAST/T is designed to handle your small casting requirements (up to 25 rings) and includes a step-by-step operating manual and video CD. Made in Germany. Two-year limited manufacturer's warranty.

Item	Order #	Description	1+
A	21-7040	Tabletop Machine Kit	\$3,445.00
B	21-7043	Metal Ring Sectioned (30mm)	\$86.10
C	21-7044	Metal Ring (30mm)	\$71.75
D	21-7045	Metal Ring (60mm)	\$72.75
E	21-7054	Mold Base	\$45.85
F	21-7046	Wax Discs for standard (pack of 25)	\$27.10
G	21-7049	Investment Liquid	\$15.40
H	21-7053	Stainless Steel Cleaning Solution 100ml	\$9.15
J	22-5811	2-Part - Silicone Mold Rubber	\$74.90
K	21-7055	Ceramic Liner (55mm W x 40mm L)	\$53.10
L	21-7056	Ceramic Liner (25mm W x 40mm L)	\$44.90
M	21-7059	Invest RP Investment for Rapid Prototype Materials	\$56.60
N	21-7060	Invest RP Investment with 1L Invest Liquid	\$66.90



**NO WAX LIGHT-UP BOX**

Powerful light-curing device with four fluorescent lamps for curing Ti-Light patterns and most common light curing resins.

Order #	Description	1+
21-7042	No Wax Light Up Box	\$100.95







31 lbs

**OIL-LESS VACUUM PUMP AND MOTOR**

Direct-drive, two-stage, high-vacuum pump features a free air displacement of 85 liters per minute (3CFM) to produce a vacuum of 25 microns or better. Powerful 1/2HP, 1725 rpm, 120V (60 Hz) motor. Intake nipple OD 1/4". A replacement for most vacuum casting or investing machines using 9" diameter x 8" height bell jars requiring a high vacuum of 29.9" of mercury. Made in the USA.

Order #	Description	1+
22-1170	Oil-Less Vacuum Pump and Motor	\$514.95



35 lbs

**VACUUM PUMP**

Two-stage deep draw vacuum pump, 1/2HP/ 110v, 3CFM

Order #	Description	1+
22-1200	3CFM	\$476.95



35 lbs

**VACUUM PUMP**

Two-stage deep draw vacuum pump, 3/4HP/ 110v, 8CFM

Order #	Description	1+
22-1201	8 CFM	\$630.80



**GRIFFITH VACUUM PUMP OIL**

A specially-formulated oil used for casting machines and vacuum pumps.

Item	Order #	Description	Capacity	12+	6+	1+
A	54-9000	Pump Oil Bottle	16 oz	\$9.38	\$9.79	\$10.20
B	54-9002	Pump Oil Bottle	32 oz	\$12.93	\$13.49	\$14.05

**JUMBO FIREBRICK FURNACE**

Extra-large capacity firebrick furnace with a chamber measuring ID 22" x 22" x 13" features a heavy-gauge steel shell, deeply recessed heating elements, and a swing door to allow easy access to the rear of the chamber. Back of the furnace is predrilled to accommodate optional pyrometer or controller thermocouple. Includes a wax elimination tray. Maximum temperature: 2,000 degrees Fahrenheit (1,093 degrees Celsius). Electrical requirements: 240V, 24 amps, 50/60 hz, 5,760 watts. Furnace controller **22-1112** or Pyrometer **22-1600**. Made in the USA.

Item	Order #	Description	WxLxH	1+
A	22-1070	Jumbo Furnace 240V	30 1/2"x27"x23"	\$1,161.64

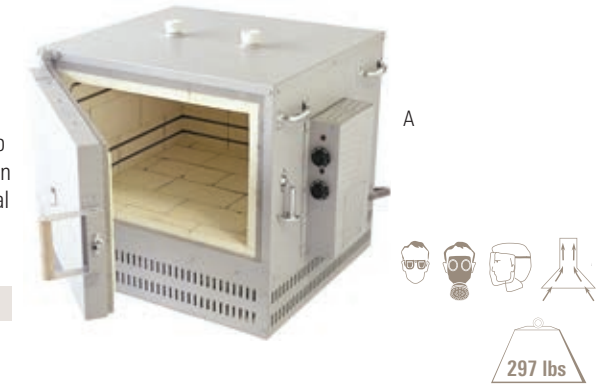

297 lbs

**LARGE FIREBRICK FURNACE**

Large capacity firebrick furnace, chamber dimensions ID 13" x 13 1/2" x 8 3/4" features a heavy-gauge steel shell, deeply recessed heating elements, counter-weighted door, 10-setting switch, and a top vent. Back of the furnace is predrilled to accommodate optional pyrometer or controller thermocouple. Comes with wax elimination tray. Made in the USA.

- Maximum temperature: 2,000 degrees Fahrenheit/1,093 degrees Celsius
- Electrical requirements: 240V, 13amps, 50/60hz
- Options: Furnace controller **22-1112** or Pyrometer **22-1600**

Item	Order #	Description	WxLxH	1+
B	22-1060	Large Furnace 240V	21 1/2"x19"x18"	\$946.95

REPLACEMENT PARTS

C	22-1061	Heating Element (Set of 2)		\$106.90
D	22-1062	Wax Elimination Tray (included)	11 1/2"x11 1/2"	\$20.95

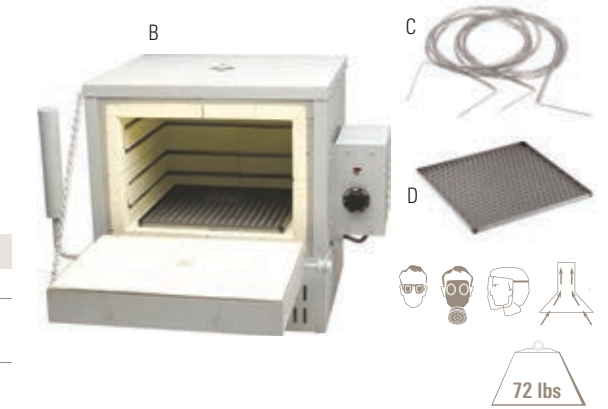

72 lbs

**MEDIUM FIREBRICK FURNACE**

Medium-size firebrick furnace with a chamber measuring ID 8 1/2" x 9" x 8 3/4" features a heavy-gauge steel shell, deeply recessed heating elements, counter-weighted door, 10-setting switch, and a top vent. Back of furnace is predrilled to accommodate optional pyrometer or controller thermocouple. Includes a wax elimination tray. Maximum temperature: 2,000 degrees Fahrenheit/1,093 degrees Celsius. Electrical requirements: 120V, 50/60hz, 14.1 amps. Furnace Controller **22-1100**, Pyrometer **22-1600**. Made in the USA.

Item	Order #	Description	WxLxH	1+
E	22-1055	Medium Furnace 120V	17 1/2"x15"x18"	\$844.15

REPLACEMENT PARTS

F	22-1056	Heating Element (Set of 2)		\$85.60
G	22-1057	Wax Elimination Tray (included)	7"x7"	\$39.40

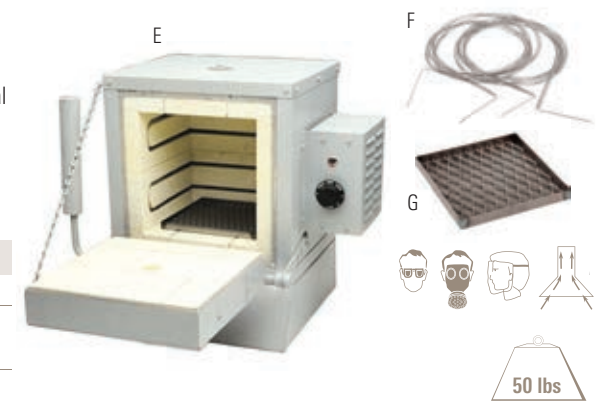

50 lbs

**SMALL FIREBRICK FURNACE 120V**

Small capacity firebrick furnace features a heavy-gauge steel shell, deeply recessed heating elements, and a swing door with inspection port. Comes with a wax elimination tray.

- Maximum temperature: 2,000 degrees Fahrenheit/1,093 degrees Celsius
- Electrical Requirements: 120V - 14 amps - 50/60 hz
- Chamber Measures: 6"w x 6"h x 6"d
- Optional: Furnace Controller **22-1100** or **22-1600** Pyrometer

Item	Order #	Description	WxLxH	1+
H	22-1051	Small Furnace 120V	6"x6"x6"	\$589.95

REPLACEMENT PARTS

J	22-1053	Wax Elimination Tray (included)	5"x5"	\$12.25
---	---------	---------------------------------	-------	---------

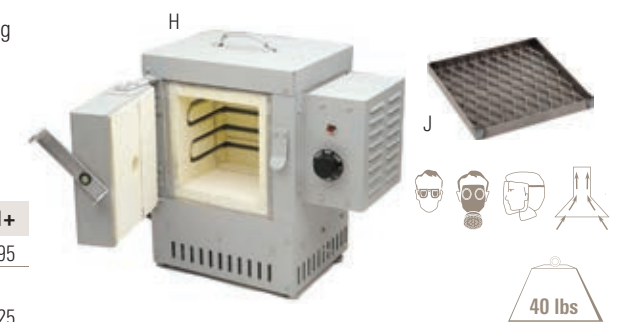

40 lbs



UL approved

Outside Dimensions:  
16.25" W x 19" H x 21.5" D



**FIBER FURNACE WITH CONTROLLER**

This small capacity (7¾" W x 7¾" H x 8" D chamber) is an easy-to-use muffle kiln with a top vent for burnout. Fully programmable controller features the Sentry Xpress Three-Button Digital Controller with custom burnout program capability as well as built-in five, eight, and 12-hour preset programs.

- Maximum temperature: 2,000 degrees Fahrenheit/1,093 degrees Celsius
- Electrical Requirements: 120V/15A
- Ship weight 41 lbs.

Item	Order #	Description	1+
A	<b>22-1005</b>	Fiber Furnace with Controller	\$955.00

**FIBER FURNACE WITH CONTROLLER**

This larger capacity (10½" W x 7" H x 10½" D chamber) is a user-friendly muffle kiln with a top vent for burnout. Fully programmable controller features the Sentry 2.0, 12-Button Controller with three standard built in programs, custom program capability, delay start, alarm, skip segment and more.

- Maximum temperature: 2,000 degrees Fahrenheit/1,093 degrees Celsius
- Electrical Requirements: 120V/15A

Item	Order #	Description	1+
B	<b>22-1008</b>	Fiber Furnace with Controller	\$1,495.00

**NEYCRAFT® FIBER FURNACE**

Compact, electric furnace features alumina-silica fiber insulation with embedded heating elements for lighter, faster heating than a firebrick furnace. Made of 20-gauge steel. Cabinet remains cool. Unit comes with pyrometer.

- Maximum temperature: 2,000 degrees Fahrenheit
- Chamber measures: 9" W x 9" H x 6½" D
- Ceramic wax elimination tray: 8" x 8"
- Electrical requirements: 120V, 12 amps, 50/00hz, 1400 watts

Item	Order #	Description	1+
C	<b>22-1000</b>	Fiber Furnace	\$1,240.36
D	<b>22-1123</b>	Fiber Hardening Agent	\$8.95
E	<b>22-1124</b>	Replacement Muffle 120V	\$344.75
F	<b>22-1101</b>	Infinity Controller	\$47.95

**VULCAN® BENCHTOP FURNACES**

The Vulcan programmable air exchange furnaces offers faster, cleaner burnout than traditional furnaces. Preheated air is drawn through the chamber and removed with an internal Venturi Exhaust System. The removal of all ash and other contaminants make this furnace ideal for platinum burnout. Programmable temperature ranging from 122-2012 degrees Fahrenheit assures precision firing. Nine three-stage programs, icon graphics for easy data entry, and advanced hybrid muffle design make this furnace a requirement for any product casting operation. Two-year manufacturer's warranty.

- Max Temperature: 2,012 degrees Fahrenheit (1,100 degrees Celsius)
- Exterior Dimensions: 15.8" W x 16" H x 17" D
- Interior Dimensions: 9" W x 7" H x 9" D
- Flask Capacity: Solid, 15 - 2" x 3", 4 - 4" x 6"; Perforated, 2 - 4" x 6"
- Power: 240V/7.2 amps/2200 watts

Item	Order #	Description	1+
G	<b>22-1045</b>	Vulcan 3550A Furnace with Air Exchange, 230V	\$3,191.87
H	<b>22-1047</b>	Replacement Muffle 240V	\$698.25

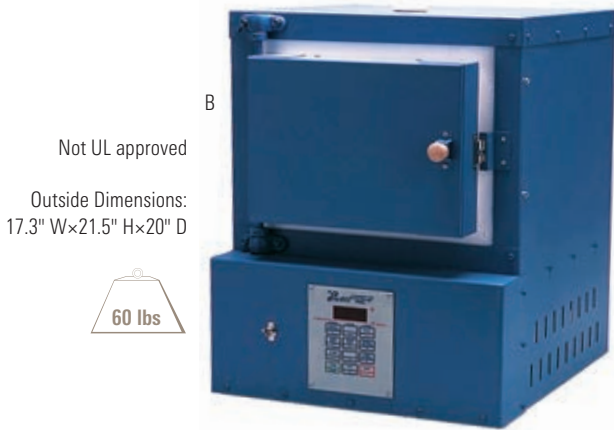

Not UL approved

Outside Dimensions:  
17.3" W x 21.5" H x 20" D



Outside Dimensions:  
15" W x 14.3" H x 14.13" D

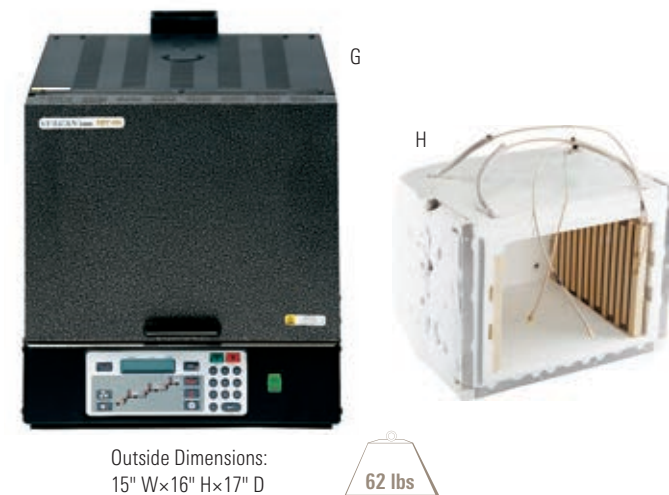

Outside Dimensions:  
15" W x 16" H x 17" D



CONNECTORS/RECEPTACLE CONFIGURATIONS		15 Ampere		20 Ampere		30 Ampere	
		Rececle	Plug	Receptacle	Plug	Receptacle	Plug
2P3w Grounding	125V						
		<b>22-1100</b>	<b>22-1100</b>	<b>22-1110</b>	<b>22-1110</b>		
2P3w Grounding	240V						
						<b>22-1112</b>	<b>22-1112</b>
3P3w Grounding	125V/250V						
							Special order plugs for older models

**STULLER FURNACE CONTROLLER**

Programmable controller for burnout furnaces with three pre-programmed cycles and six easily custom programmed to the individual casters needs. Easy start up:

- Choice of a 5-hour, 8-hour or 12-hour cycle by touch entry key.
- Step-by-step instructions for creating a custom burnout cycle are easy to follow.

Added features:

- Power failure protection, delay start time from 1 minute to 99 hours (great for overnight burnouts), a reminder signal to remove wax trays, and digital temperature readout.
- Self-standing or can be easily mounted to a wall.
- Comes with thermocouple.
- Dimensions: 16" x 4" x 7".

Item	Order #	Description	Volts	Amps	Hertz	1+
A	<b>22-1100</b>	Controller	120	15	60	\$695.95
	<b>22-1110</b>	Controller	120	20	60	\$695.95
	<b>22-1112</b>	Controller	240	30	50/60	\$729.00
B	<b>22-1113</b>	Replacement Thermocouple				\$62.05



**PYROMETER**

Use to measure temperature in burnout ovens. Measures within 98% accuracy, from 0 to 2,500 degrees Fahrenheit on meter. Has five-inch lead and sheathed 1/8" thermocouple.

Order #	Description	1+
<b>22-1600</b>	Analog (Needle) Pyrometer	\$165.85







**STRESS-RELIEVED QUARTZ STIRRING ROD**

Use to stir molten metal. Made of superior quality clear quartz, annealed and fire polished. Melting point 3,183 degrees Fahrenheit (1,750.6 degrees Celsius).

Item	Order #	OD	Length	12+	6+	1+
A	21-9050	3/8"	12"	\$18.49	\$19.30	\$20.10



**CARBON STIRRING RODS**

Use to stir gold while melting in crucibles.

Item	Order #	OD	Length	12+	6+	1+
B	22-9001	1/4"	9"	\$4.19	\$4.37	\$4.55
C	22-9002	1/2"	12"	\$7.31	\$7.63	\$7.95

**KERR® AUTO STANDARD ELECTRO-MELT?**

Digitally controlled, the Kerr® standard Electro-Melt™ is recommended when sustained high-temperature use is required. Electronic controller regulates the temperature by providing full power input until a preselected temperature is attained. Maximum temperature: 2,012 degrees Fahrenheit/1,100 degrees Celsius. Melting capacity for gold 930g/30oz; silver 775g/25oz. Empty crucible 1,800 degrees Fahrenheit/982 degrees Celsius in 22 minutes. Both CE, CSA Certified.

Item	Order #	Description	Volts	1+
D	22-1029	Auto Standard Electro-Melt	120V	\$1,150.00

REPLACEMENT PART

E	15-0526	Heating Element		\$355.50
---	---------	-----------------	--	----------



**KERR® AUTO MAXI ELECTRO-MELT?**

The Kerr® Maxi Electro-Melt™ has a melting capacity of up to 100 ounces of gold or 83 ounces of silver. Digitally controlled, the electronic controller regulates the temperature by providing full power input until the preset temperature is reached. Maximum temperature: 2,012 degrees Fahrenheit/1,100 degrees Celsius. Melting capacity of gold 3.1 kg/100 oz.; silver 2.6 kg/83 oz. Empty crucible 1,800 degrees Fahrenheit/982 degrees Celsius in 31. Both CE, CSE Certified.

Item	Order #	Description	Volts	1+
F	22-1035	Auto Maxi Electro-Melt	120V	\$1,008.00

**GROBET USA® DIGITAL METAL MELT**

Specially designed and constructed for melting metals for casting and alloying. Features 2,050 degrees Fahrenheit/1,120 degrees Celsius operating range. Has heavy-duty graphite crucible, precise temperature control, LED on/off indicator light, one-kilogram (32 oz) capacity, easy-to-read digital display, and 110V-50/60 cycle power.

Item	Order #	Description	1+
G	22-2110	Digital Metal Melt	\$861.00

REPLACEMENT PARTS

H	22-2111	Crucible (11.37 oz)	\$28.90
J	22-2112	Heating Element (5 lb)	\$363.60

Find added video content on [Stuller.com/VideoCenter](http://Stuller.com/VideoCenter).



**FILE-A-WAX ORANGE MILLING WAX**

This revolutionary wax (burnt orange) was developed for wax milling. The milling wax is available in round, flat tablets, solid bars, and multiple ring tube sizes. The wax is harder than the green standard wax. Great for all CAD milling machines or hand wax carving. Melt point 232 degrees Fahrenheit.

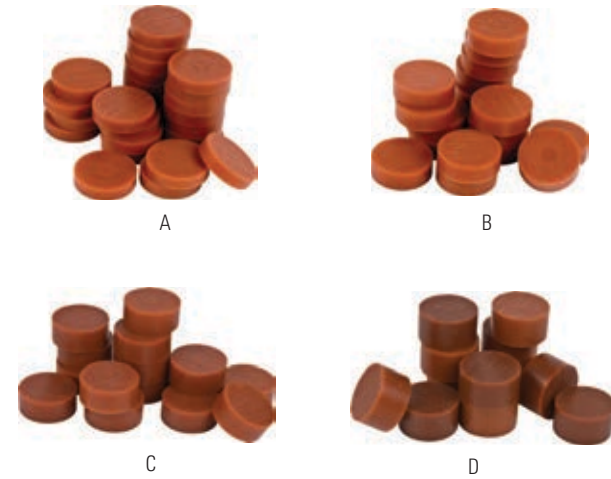

**FLIP FIXTURE DISCS**

Item	Order #	OD	Height	Per Pack	12+	6+	1+
A	21-9101	2"	0.42"	27 discs	\$29.21	\$30.48	\$31.75
B	21-9102	2"	0.63"	18 discs	\$29.21	\$30.48	\$31.75
C	21-9103	2"	0.83"	15 discs	\$29.21	\$30.48	\$31.75
D	21-9104	2"	1"	12 discs	\$29.21	\$30.48	\$31.75

**CARVING SLICES**

Item	Order #	WxLxH	12+	6+	1+
E	21-9120	2 3/8" x 2 3/8" x 0.32"	\$12.37	\$13.10	\$14.55
F	21-9121	2 3/8" x 2 3/8" x 0.47"	\$12.37	\$13.10	\$14.55
G	21-9122	2 3/8" x 2 3/8" x 0.7"	\$12.37	\$13.10	\$14.55

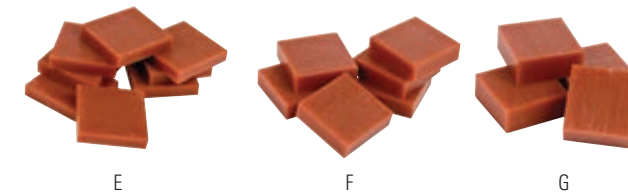

**MILLING WAX SLICES**

Order #	WxLxH	Per Pack	12+	6+	1+
21-9099	2" x 2" x 0.2"	16 slices	\$12.37	\$13.10	\$14.55



**FILE-A-WAX ORANGE MILLING WAX**

Order #	WxLxH	Per Pack	12+	6+	1+
21-9114	2" x 4" x .42"	4 slices	\$11.35	\$12.02	\$13.35
21-9115	2" x 4" x .49"	3 slices	\$11.35	\$12.02	\$13.35
21-9116	2" x 4" x 0.72"	2 slices	\$11.35	\$12.02	\$13.35
21-9117	1/2 lb kit	5 slices	\$12.37	\$13.10	\$14.55
21-9118	1 lb kit	9 tablets	\$21.84	\$24.57	\$27.30



1/2-lb Kit Contains  
 2- 4"x2"x.23" slices  
 2- 4"x2"x.42" slices  
 1- 4"x2"x.72" slice  
 1-lb Kit Contains  
 2- 4"x2"x.23" tablets  
 2- 4"x2"x.32" tablets  
 2- 4"x2"x.42" tablets  
 2- 4"x2"x.49" tablets  
 1- 4"x2"x.72" tablet

**WHICH FILE-A-WAX FORMULA IS RIGHT FOR YOUR NEXT PATTERN?**

	Blue	Purple	Green	Gold	Orange
<b>Flexibility</b>	Excellent	Good	Fair	Good	Poor
<b>Hand Carvability</b>	Good	Excellent	Fair	Good	Fair
<b>Hardness (Shore D)</b>	52 (Softest)	55	55	58	63 (Hardest)
<b>High-Speed CNC</b>	Poor	Fair	Good	Excellent	Excellent
<b>Viscosity at 300° (cPs)</b>	3650	3350	1560 (Thinnest)	2030	3550

All items are priced at jeweler's cost, are sold each, unless otherwise noted, and are subject to change without notice. Visit [Stuller.com](http://Stuller.com) for our complete product selections, current pricing, and quantity price breaks. | 155



**MATT™ WAX BARS**

A special wax used for making models. Can be carved, sawed, filed, machined, or turned on a lathe.

Order #	Shape	Color	W×L×H	12+	6+	1+
<b>21-0436</b>	Block	Assorted	1½"×3½"×1½"	\$7.89	\$8.55	\$9.50

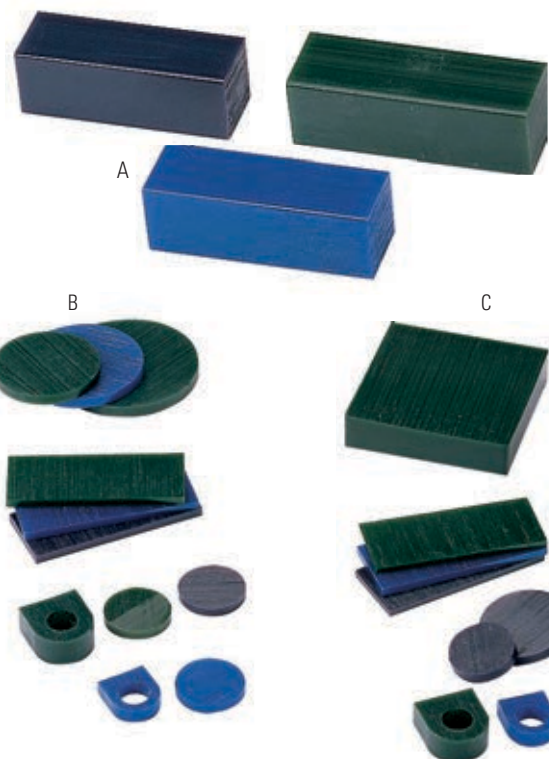

**WAX BLOCK KIT**

- A. Wax Block Kit:** Includes one block each of green (hard), purple (medium), and blue (soft).
- B. Student Kit:** Features an assortment of 11 pieces of various shapes and sizes. Includes combination of all three hardness grades: blue (regular), green (hard), and purple (medium).
- C. Professional Kit:** This kit contains a 14-piece assortment of designers' favorite shapes and sizes. Available in three hardness grades: blue (regular), green (hard), and purple (medium).

Item	Order #	Description	W×L×H	12+	6+	1+
A	<b>21-0207</b>	Wax Block Kit	1½"×3½"×1¼"	\$10.44	\$10.90	\$11.35
B	<b>21-0208</b>	Student Kit	Assorted Slices	\$12.56	\$13.10	\$13.65
C	<b>21-0209</b>	Professional Kit	Assorted Slices	\$17.30	\$18.05	\$18.80

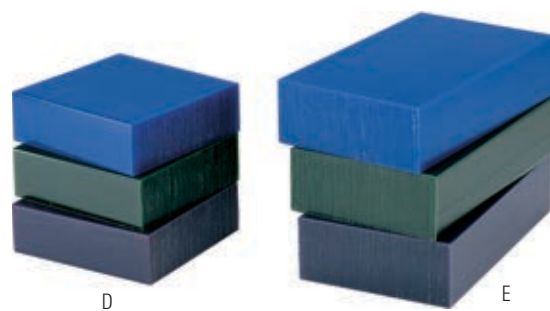

**FILE-A-WAX BLOCKS**

Ideal for freeform design work, modeling, and rapid prototyping, these blocks are available in three hardness grades: blue (regular), green (hard), and purple (medium).

**Order # 21-03200**

Item	Shape	Color	W×L×H	12+	6+	1+
D	Block	Green	3½"×3½"×1½"	\$9.05	\$9.59	\$10.65
	Block	Purple	3½"×3½"×1½"	\$9.05	\$9.59	\$10.65
	Block	Blue	3½"×3½"×1½"	\$9.05	\$9.59	\$10.65
E	Block	Green	3⅝"×6"×1½"	\$15.05	\$15.93	\$17.70
	Block	Purple	3⅝"×6"×1½"	\$15.05	\$15.93	\$17.70
	Block	Blue	3⅝"×6"×1½"	\$15.05	\$15.93	\$17.70

**FILE-A-WAX RING TUBES**

Stuller's wax ring tubes offer a comprehensive blend of carving versatility and flexibility. Convenient and easy-to-use, these wax tubes are perfect for designing a wide selection of rings, jewelry, and small art pieces. Ring tubes have a ⅝" off-center hole.

**Order # 21-13400**

Item	Shape	Color	W×L×H	12+	6+	1+
A	Flat-Sided Tube	Green	1⅝"×6"×1⅜"	\$8.16	\$8.64	\$9.60
	Flat-Sided Tube	Purple	1⅝"×6"×1⅜"	\$8.16	\$8.64	\$9.60
	Flat-Sided Tube	Blue	1⅝"×6"×1⅜"	\$8.16	\$8.64	\$9.60
B	Flat-Sided Tube	Green	1⅝"×6"×1⅝"	\$8.16	\$8.64	\$9.60
	Flat-Sided Tube	Purple	1⅝"×6"×1⅝"	\$8.16	\$8.64	\$9.60
	Flat-Sided Tube	Blue	1⅝"×6"×1⅝"	\$8.16	\$8.64	\$9.60
C	Flat-Sided Tube	Green	1⅝"×6"×1"	\$8.16	\$8.64	\$9.60
	Flat-Sided Tube	Purple	1⅝"×6"×1"	\$8.16	\$8.64	\$9.60
	Flat-Sided Tube	Blue	1⅝"×6"×1"	\$8.16	\$8.64	\$9.60
D	Flat-Sided Tube	Green	1"×6"×1"	\$8.16	\$8.64	\$9.60
	Flat-Sided Tube	Purple	1"×6"×1"	\$8.16	\$8.64	\$9.60
	Flat-Sided Tube	Blue	1"×6"×1"	\$8.16	\$8.64	\$9.60
E	Round Tube-Off Center Hole	Green	1⅝"×6"	\$8.16	\$8.64	\$9.60
	Round Tube-Off Center Hole	Purple	1⅝"×6"	\$8.16	\$8.64	\$9.60
	Round Tube-Off Center Hole	Blue	1⅝"×6"	\$8.16	\$8.64	\$9.60
F	Round Tube-Center Hole	Green	1⅝"×6"	\$8.16	\$8.64	\$9.60
	Round Tube-Center Hole	Purple	1⅝"×6"	\$8.16	\$8.64	\$9.60
	Round Tube-Center Hole	Blue	1⅝"×6"	\$8.16	\$8.64	\$9.60
G	Round Tube-Center Hole	Green	⅞"×6"	\$8.16	\$8.64	\$9.60
	Round Tube-Center Hole	Purple	⅞"×6"	\$8.16	\$8.64	\$9.60
	Round Tube-Center Hole	Blue	⅞"×6"	\$8.16	\$8.64	\$9.60
H	Solid Bar	Green	1⅝"×6"	\$8.16	\$8.64	\$9.60
	Solid Bar	Purple	1⅝"×6"	\$8.16	\$8.64	\$9.60
	Solid Bar	Blue	1⅝"×6"	\$8.16	\$8.64	\$9.60
J	Solid Bar	Green	⅞"×6"	\$8.16	\$8.64	\$9.60
	Solid Bar	Purple	⅞"×6"	\$8.16	\$8.64	\$9.60
	Solid Bar	Blue	⅞"×6"	\$8.16	\$8.64	\$9.60

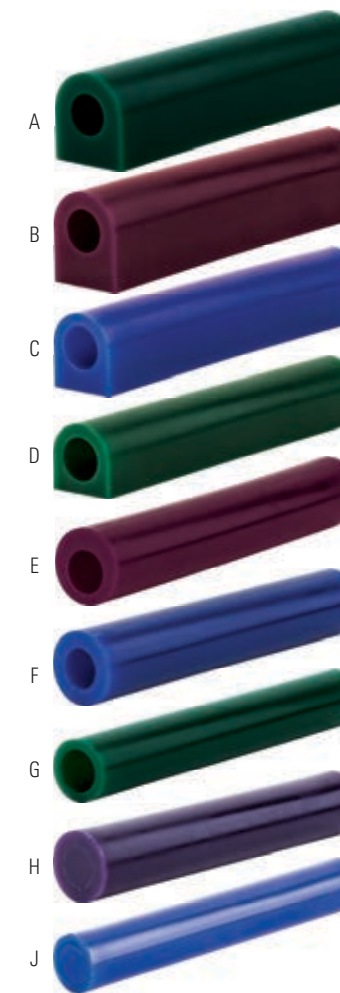

Available in three degrees of flexibility. Specify color when ordering.

Melt Temperatures	Green (hard), 230°F	Purple (medium), 225°F	Blue (soft), 200°F
Shrinkage for	7-10%	less than 1%	7-10%

**MATT™ WAX RODS**

Designed for use with the Matt™ mini-lathe (page 138, 21-2800). Each box contains four 1½" rods. Specify color (green, purple, or blue) when ordering.

**Order # 21-05310**

Item	Color	Width	12+	6+	1+
K	Green	1⅝"	\$8.38	\$9.09	\$10.10
	Purple	1⅝"	\$8.38	\$9.09	\$10.10
	Blue	1⅝"	\$8.38	\$9.09	\$10.10
L	Green	1⅜"	\$8.38	\$9.09	\$10.10
	Purple	1⅜"	\$8.38	\$9.09	\$10.10
	Blue	1⅜"	\$8.38	\$9.09	\$10.10
M	Green	⅞"	\$8.38	\$9.09	\$10.10
	Purple	⅞"	\$8.38	\$9.09	\$10.10
	Blue	⅞"	\$8.38	\$9.09	\$10.10

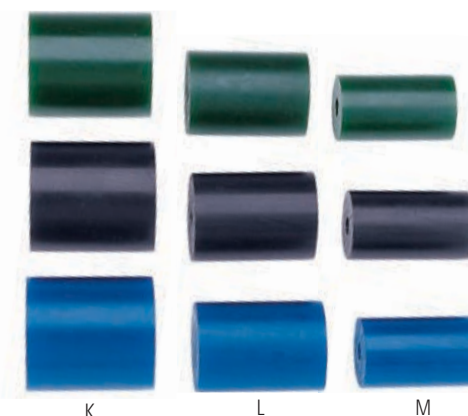





**MATT™ GUN KIT**

Versatile, extrusion technique for creating models is provided to you through the use of the Matt gun. Allows you to individually control the temperature and pressure of the extrusion process. Three different methods of design can be achieved: on objects, freeform, and on water. Kit contains Matt gun, two brass tips, three styles of wax, and a 113-page instruction book. 110V.

Order #	Description	1+
<b>21-0955</b>	Matt Gun Kit	\$165.00
<b>REPLACEMENT PARTS</b>		
<b>21-0956</b>	Blue Pellets for Mandrel Design (pack of 20)	\$9.90
<b>21-0957</b>	Green Pellets for Water Design (pack of 20)	\$9.90
<b>21-0958</b>	Red Pellets for Weaving (pack of 20)	\$9.90



**MATT™ WAX REAMER**

With the Matt reamer, you can quickly create perfect wax blanks with smooth parallel walls, and bore finger sizes (to the exact dimensions) straight through the blanks. You can also create bezels for round stones or coin holders. The reamer consists of a precision ground steel rod with a holding knob. Two specially designed carbide blades ensure the tool's precision and long life.

Order #	Description	1+
<b>21-2835</b>	Reamer	\$64.35



**MATT™ RING TUBE SIZER**

Enlarge the finger size of your wax models quickly and accurately. Hardwood mandrel is specially machined to incorporate a cutting steel blade that extends from the handle to the tip on the tapered section. Slide this tool through the hole of wax ring or ring tube and gently rotate clockwise. As the blade turns, it scribes inner wall, enlarging the ring to the size that is marked along the mandrel and leaving a smooth and even finish on the ring.

Order #	Description	1+
<b>21-2895</b>	Matt Ring Tube Sizer	\$33.50



**MATT™ MITER BOX**

Slices bars, rods, and wax ring tubes into perfectly straight tablets and parallel walls or tapered sides. The miter box holds ring tube firmly in position inside the box, so there is no strain on your hands. The miter box has a stop/lock feature for cutting several tablets of the same thickness. The fine steel saw blades allow you to cut through the tube with no effort, leaving a smooth finish without filing.

Order #	Description	W x L	1+
<b>21-0390</b>	Box and Saw	6"x2"	\$69.00



**MATT™ TRIMMER SET**

Files flat and curved surfaces at different angles. This unit comes with a rotary file, three different waxes, instructions, and is powered by a flex shaft and No. 30 handpiece. Handpiece and cable not supplied with unit. 115V.

Order #	Description	1+
<b>21-2880</b>	Matt Trimmer Set	\$160.00

2 lbs

**MATT™ MINI LATHE WITH GAUGE KIT**

The handheld lathe works with a flex shaft and a #30 handpiece and is used for the design of wedding bands, bezels, coin holders, and pieces as large as a chess piece. Comes with a three-piece cutting tool and a 32-page instruction book. Handpiece is not included. 115V.

**Order # 21-28000**

Item	Description	1+
A	Blade Set (3-Pieces)	\$18.70
B	Wax Holding Collet	\$6.50
C	Cutting Tool Square End	\$6.60
D	Cutting Tool Blank End	\$4.75
	Green Replacement Wax Rods (4-Pieces)	\$11.95
	Purple Replacement Wax Rods (4-Pieces)	\$11.95
	Blue Replacement Wax Rods (4-Pieces)	\$11.95

**Kit Order # 21-28000**

Description	1+
Mini Lathe with Gauge Kit (shown)	\$165.00



**MATT™ WAX RING TUBES**

Available in three degrees of flexibility: green (hard); purple (medium); and blue (soft). Specify color when ordering.

**Order # 21-02150**

Item	Shape	Color	W×L×H	12+	6+	1+
E	Flat-Sided Tube	Green	1"×6"×1½"	\$7.10	\$7.52	\$8.35
	Flat-Sided Tube	Purple	1"×6"×1½"	\$7.10	\$7.52	\$8.35
	Flat-Sided Tube	Blue	1"×6"×1½"	\$7.10	\$7.52	\$8.35
F	Flat-Sided Tube	Green	1½"×6"×1½"	\$7.10	\$7.52	\$8.35
	Flat-Sided Tube	Purple	1½"×6"×1½"	\$6.55	\$6.93	\$8.35
	Flat-Sided Tube	Blue	1½"×6"×1½"	\$6.55	\$6.93	\$8.35
G	Flat-Sided Tube	Green	1¼"×6"×1¼"	\$6.55	\$6.93	\$8.35
	Flat-Sided Tube	Purple	1¼"×6"×1¼"	\$7.10	\$7.52	\$8.35
	Flat-Sided Tube	Blue	1¼"×6"×1¼"	\$7.10	\$7.52	\$8.35
H	Solid Round Tube	Green	¾"×6"	\$7.01	\$7.43	\$8.25
	Solid Round Tube	Purple	¾"×6"	\$7.10	\$7.52	\$8.35
	Solid Round Tube	Blue	¾"×6"	\$7.10	\$7.52	\$8.35
J	Solid Round Tube	Green	1½"×6"	\$7.01	\$7.43	\$8.25
	Solid Round Tube	Purple	1½"×6"	\$7.10	\$7.52	\$8.35
	Solid Round Tube	Blue	1½"×6"	\$7.10	\$7.52	\$8.35
K	Solid Round Tube	Green	1½"×6"	\$7.10	\$7.52	\$8.35
	Solid Round Tube	Purple	1½"×6"	\$7.10	\$7.52	\$8.35
	Solid Round Tube	Blue	1½"×6"	\$7.10	\$7.52	\$8.35
L	Round Tube Center Hole	Green	¾"×6"	\$7.10	\$7.52	\$8.35
	Round Tube Center Hole	Purple	¾"×6"	\$7.10	\$7.52	\$8.35
	Round Tube Center Hole	Blue	¾"×6"	\$7.10	\$7.52	\$8.35
M	Round Tube Center Hole	Green	1½"×6"	\$7.10	\$7.52	\$8.35
	Round Tube Center Hole	Purple	1½"×6"	\$7.10	\$7.52	\$8.35
	Round Tube Center Hole	Blue	1½"×6"	\$7.10	\$7.52	\$8.35
N	Round Tube Center Hole	Green	1½"×6"	\$7.10	\$7.52	\$8.35
	Round Tube Center Hole	Purple	1½"×6"	\$7.10	\$7.52	\$8.35
	Round Tube Center Hole	Blue	1½"×6"	\$7.10	\$7.52	\$8.35
P	Round Tube Off-Center Hole	Green	1½"×6"	\$7.10	\$7.52	\$8.35
	Round Tube Off-Center Hole	Purple	1½"×6"	\$6.55	\$6.93	\$8.35
	Round Tube Off-Center Hole	Blue	1½"×6"	\$7.10	\$7.52	\$8.35

Available in three degrees of flexibility. Specify color when ordering.

Green (hard), 7-10% shrink	Purple (medium), 1% shrink	Blue (soft), 7-10% shrink
----------------------------	----------------------------	---------------------------

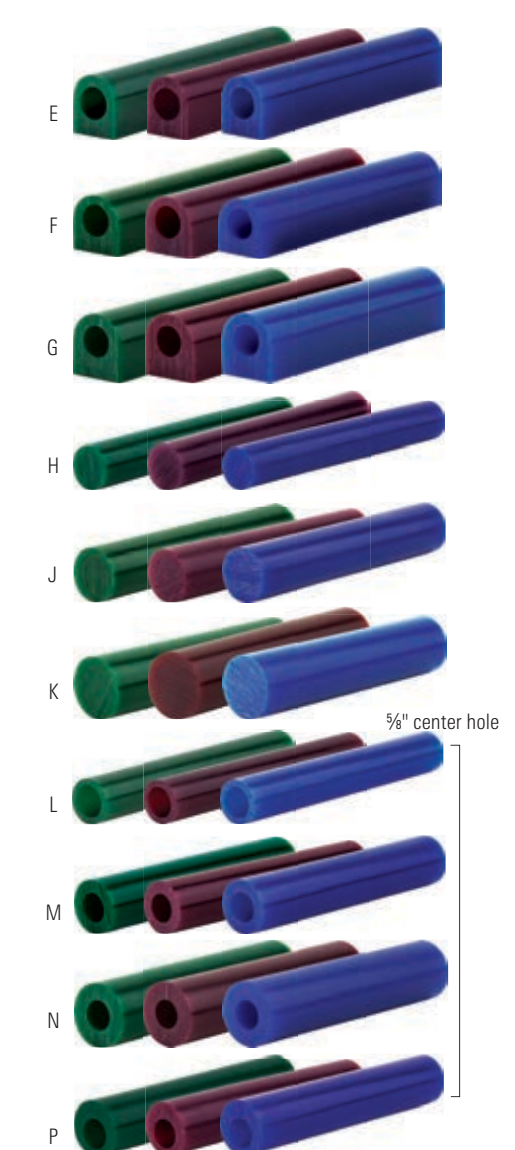

5/8" center hole



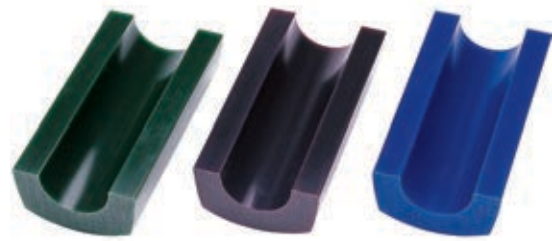

**MATT™ BRACELET WAX BARS**

Designed for use with the Matt™ shape, these six-inch arch-shaped bars simplify the construction of bracelets. Create round, oval, and square designs in a variety of sizes.

Order # 21-05190

Color	Length	Weight	12+	6+	1+
Green	6"	1 lb	\$15.31	\$16.61	\$18.45
Purple	6"	1 lb	\$15.31	\$16.61	\$18.45
Blue	6"	1 lb	\$15.31	\$16.61	\$18.45



**MATT™ WAX SLICES**

Slices assorted from 1/4" to 1" in thickness.

Order # 21-02660

Color	W×L	Weight	12+	6+	1+
Green	1 7/16"×3 1/8"	1/2 lb	\$10.40	\$10.85	\$11.30
Purple	1 7/16"×3 1/8"	1/2 lb	\$10.40	\$10.85	\$11.30
Blue	1 7/16"×3 1/8"	1/2 lb	\$10.40	\$10.85	\$11.30

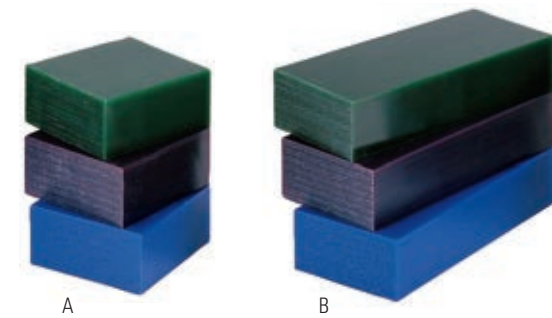

**MATT™ WAX BARS**

A special wax used for making models, these bars can be carved, sawed, filed, machined, or turned on a lathe. Available in three grades of flexibility: green, purple, and blue. Specify color when ordering.

Order # 21-04300

Item	Description	Color	W×L×H	12+	6+	1+
A	1/2 lb Bar	Green	3 3/8"×3 3/8"×1 1/16"	\$9.52	\$9.94	\$10.35
	1/2 lb Bar	Purple	3 3/8"×3 3/8"×1 1/16"	\$9.52	\$9.94	\$10.35
	1/2 lb Bar	Blue	3 3/8"×3 3/8"×1 1/16"	\$9.52	\$9.94	\$10.35
B	1 lb Bar	Green	3 3/8"×6 1/2"×1 1/16"	\$12.28	\$12.82	\$13.35
	1 lb Bar	Purple	3 3/8"×6 1/2"×1 1/16"	\$12.28	\$12.82	\$13.35
	1 lb Bar	Blue	3 3/8"×6 1/2"×1 1/16"	\$12.28	\$12.82	\$13.35

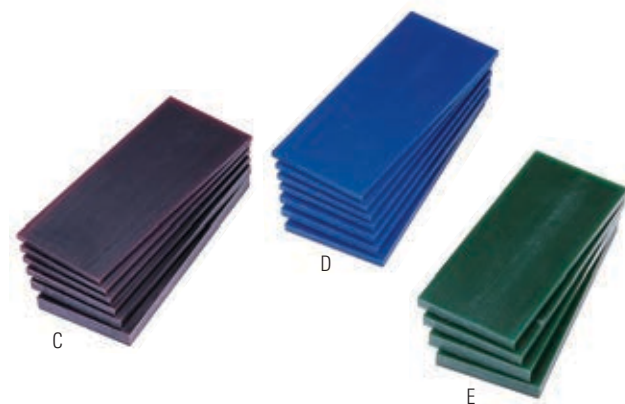

**MATT™ WAX CARVING TABLETS**

These smooth, precision wax tablets provide jewelry designers and model makers with large, flat, incredibly smooth surfaces for designing jewelry directly onto carving wax. The tablets save time and money by eliminating the filing and surface preparation that is required with standard wax slices. The tablet size is produced in four thicknesses: 4.5mm, 6mm, 8mm, and 10.5mm. Available in three assorted sets. Specify color (green, purple, or blue) when ordering.

Set C contains thickness of 3-4.5mm, 1-8mm, 1-10.5mm

Set D contains thickness of 4-4.5mm, 3-6mm

Set E contains thickness of 2-8mm, 2-10.5mm

Order # 21-05220

Item	Color	W×L	12+	6+	1+
C	Green	2 5/8"×6"	\$25.58	\$26.69	\$27.80
	Purple	2 5/8"×6"	\$25.58	\$26.69	\$27.80
	Blue	2 5/8"×6"	\$25.58	\$26.69	\$27.80
D	Green	2 5/8"×6"	\$24.79	\$25.87	\$26.95
	Purple	2 5/8"×6"	\$24.79	\$25.87	\$26.95
	Blue	2 5/8"×6"	\$24.79	\$25.87	\$26.95
E	Green	2 5/8"×6"	\$24.79	\$25.87	\$26.95
	Purple	2 5/8"×6"	\$24.79	\$25.87	\$26.95
	Blue	2 5/8"×6"	\$24.79	\$25.87	\$26.95

Available in three degrees of flexibility. Specify color when ordering.

Green	Hard	7-10% shrink
Purple	Medium	1% shrink
Blue	Soft	7-10% shrink

**MATT™ RING TEMPLATE**

Features 18 different profiles for both men's and ladies' rings from the most popular to universal designs.

Order #	Description	W×L	1+
21-0279	Ring Template	5"×8 1/4"	\$13.10

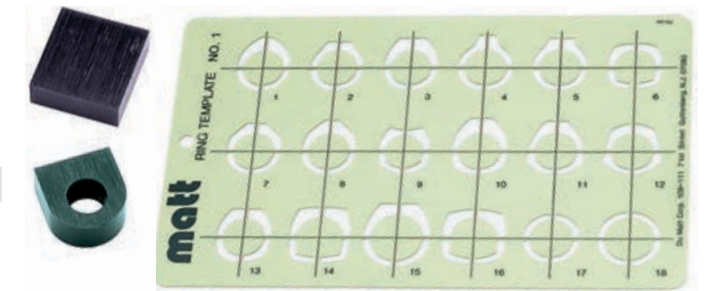

**MATT™ BRACELET TEMPLATE**

This bracelet template helps you establish the perfect profile for creating square, round, and oval bracelets. Conveniently sized for most bracelet projects.

Order #	Description	W×L	1+
21-0269	Bracelet Template	5"×8 1/4"	\$13.50

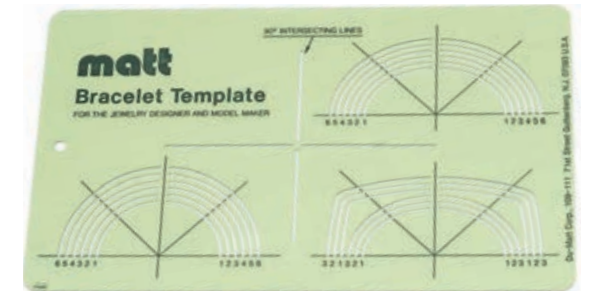

**MATT™ TECHNIQUES OF JEWELRY ILLUSTRATION AND COLOR RENDERING KIT**

Features full instruction on jewelry illustration with step-by-step guidelines and clear illustrations. The 152 pages with hardcover present full instructions on jewelry rendering and design ideas. Includes five design templates.

Order #	Description	1+
21-0540	Rendering Kit	\$99.00
21-0541	Techniques of Jewelry Illustration	\$45.35
21-0542	Set of 5 Templates	\$66.00



**JEWELRY DESIGN TEMPLATE KIT**

Allows accurate drawings of jewelry designs, this kit of seven heavy-gauge plastic templates. Includes shapes as follows: round, oval, baguette, emerald, marquise, and pear. Templates for ring and setting designs are also included along with metric and carat equivalents for accuracy and convenience.

Order #	Description	1+
35-5700	Design Templates	\$60.20







C



A

B

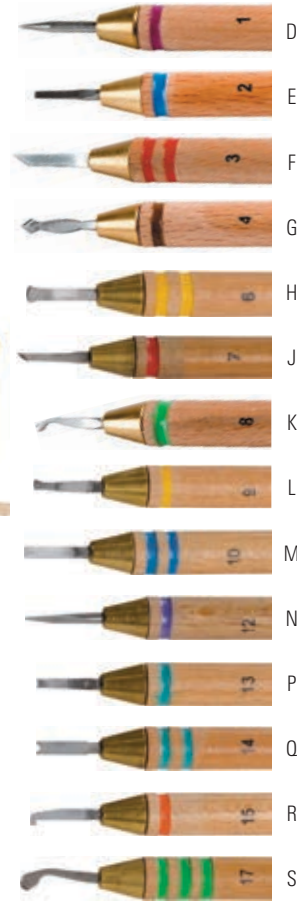

D

E

F

G

H

J

K

L

M

N

P

Q

R

S

### WOLF™ PRECISION CARVERS

Designed by Kate Wolf, master model maker and educator. These tools feature the profiles and edges that wax carvers want. Wolf's precision carvers are made of chromium and manganese, and the wood handles are color coded and numbered for quick identification. Set A includes container and 22-page, 7" x 7", full-color instructional booklet.

Order # 21-04950

Item	Description	12+	6+	1+
A	18-piece Carvers Set	\$139.40	\$147.60	\$164.00
B	8-piece Micro Carvers set	\$75.65	\$80.10	\$89.00
C	Wolf Precision Carvers	\$11.43	\$12.11	\$13.45
D	#1 Scribe/Detailing	\$10.29	\$10.89	\$12.10
E	#2 Small 90 deg	\$7.26	\$7.26	\$7.26
F	#3 Carving Knife	\$10.29	\$10.89	\$12.10
G	#4 Diamond Point	\$10.29	\$10.89	\$12.10
H	#6 Medium Rake Hollower	\$10.29	\$10.89	\$12.10
J	#7 Detailing Knife	\$10.29	\$10.89	\$12.10
K	#8 Small Hollower	\$10.29	\$10.89	\$12.10
L	#9 Small Rake Hollower	\$10.29	\$10.89	\$12.10
M	#10 Medium 90 deg/Safety Edge	\$10.29	\$10.89	\$12.10
N	#12 Tapered Triangle	\$10.29	\$10.89	\$12.10
P	#13 Small Rounding	\$10.29	\$10.89	\$12.10
Q	#14 Medium Rounding	\$10.29	\$10.89	\$12.10
R	#15 Undercutting	\$10.29	\$10.89	\$12.10
S	#17 Large Hollower	\$10.29	\$10.89	\$12.10



### WOLF™ TRIMMER

Multipurpose tool for quickly and accurately trimming carving waxes and other applications is now made easier by its ability to securely position rotary tools. The Wolf trimmer is a simple tool designed extraordinarily well for holding a #30 handpiece in use. Made primarily for trimming waxes while using a 11mm diameter cylinder bur (not supplied), the Wolf trimmer will also work with a variety of rotary tools, allowing you to use both hands and precisely locate items next to a stationary tool.

Order #	Description	12+	6+	1+
21-0455	Trimmer	\$36.13	\$38.25	\$42.50



### WOLF™ ADJUSTABLE TRIMMER

Made of aluminum, steel, and plastic, it has a removable rip fence for controlled cutting. The pivoting, sliding table adjusts from 90 degrees to 45 degrees for complex cuts. The Wolf adjustable trimmer and the Wolf trimmer slide over a #30 flex shaft handpiece. Either can be held against a bench pin, tabletop, or in a GRS® BenchMate®. Use with a cylinder bur to quickly and accurately trim carving wax. Use with separating disks on metal to cut grooves for inlay and channels. Use with abrasives for finish work on metal.

Order #	Description	12+	6+	1+
21-0456	Adjustable Trimmer	\$100.30	\$106.20	\$118.00

### COMPONENTRY WAX

Developed to help the professional wax carver with time they spend on creating channels, clasps, hinges, and other complex precision-formed wax designs, these shapes are sold in blue (medium) and available in four-inch to five-inch lengths. This full selection of shapes can be used individually or in a combination. Perfect for producing unique jewelry items as well as links, prongs, bezels, and sprues. Although extremely flexible, wire wax is strong enough to be twisted or bent to conform to any configuration or angle without cracking or breaking.

#### WAX SHAPES

- Solid Round
- Round Tube
- ◐ Solid Half-Round
- Solid Square
- ◻ Square Tube
- ▲ Triangle
- └ 90° Bezel
- Hinge Tube
- ┌ Channel
- ▬ Flat Ribbon
- ┌ Uncut Bezel
- ▬ Rectangle

2 oz



Order # 21-10000

Shape: Round

mm	.5	1	1.5	1.5
1+	\$10.35	\$10.35	\$10.35	\$10.35

mm	2	2.5	3	4
1+	\$10.35	\$10.35	\$10.35	\$10.35

Order # 21-10001

Shape: Round Tube-Center Hole

mm	1	2.5	3	3.5	4
1+	\$10.75	\$10.75	\$10.75	\$10.75	\$10.75

mm	4.5	5	5.5	6
1+	\$10.75	\$10.75	\$10.75	\$10.75



Order # 21-10002

Shape: Half-Round

mm	2	2.5	3
1+	\$10.35	\$10.35	\$10.35

mm	4	6
1+	\$10.35	\$10.35



Order # 21-10003

Shape: Square

mm	2	2.5
1+	\$10.35	\$10.35

mm	3	4
1+	\$10.35	\$10.35



Order # 21-10004

Shape: Square Tube

mm	2	2.5	3	3.5	4
1+	\$11.10	\$11.10	\$11.10	\$11.10	\$11.10

mm	4.5	5	5.5	6
1+	\$11.10	\$11.10	\$11.10	\$11.10



All items are priced at jeweler's cost, are sold each, unless otherwise noted, and are subject to change without notice. Visit [Stuller.com](http://Stuller.com) for our complete product selections, current pricing, and quantity price breaks. | 163



**Order # 21-9159**  
Shape: 90 Degree Bezel

mm	1.5
1+	\$11.10

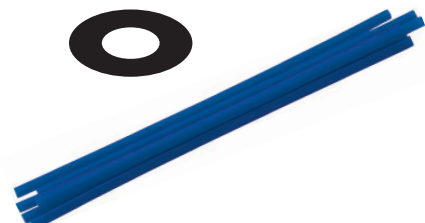

**Order # 21-10006**  
Shape: Hinge Tube

mm	2	2.5	3
1+	\$11.10	\$11.10	\$11.10

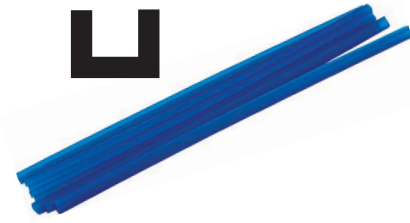

**Order # 21-10007**  
Shape: Channel Tube

mm	1.5	2	2.5
1+	\$11.10	\$11.10	\$11.10



**Order # 21-10005**  
Shape: Triangle

mm	3	3.5	4	4.5
1+	\$9.85	\$9.85	\$9.85	\$9.85



**Order # 21-10008**  
Shape: Ribbon

mm	4	5	6	7
1+	\$10.05	\$10.05	\$10.05	\$10.05



**Order # 21-10009**  
Shape: Uncut Bezel

mm	3	4	5	6
1+	\$10.05	\$10.05	\$10.05	\$10.05



**Order # 21-10010**  
Shape: Rectangle

mm	2.5	3	4	5	6
1+	\$10.05	\$10.05	\$10.05	\$10.05	\$10.05

**WAX WIRE ASSORTMENTS**

The assortment packs ensure you have a convenient selection of wire waxes when you need them. Each box contains eight different gauges of Stuller Select wire waxes cut in four-inch lengths.

**No. 1 Assortment:** 10, 14, 18 gauge; Half-round: 6, 8, 12, and 14 gauge; Half-pear: 6 gauge.

**No. 2 Assortment:** 6, 8, 10, 12, 14, 16, 18, and 20 gauge.

**No. 3 Assortment:** 2, 4, 6, 8, 10, and 12 gauge; Square: 12 and 14 gauge.

**No. 4 Assortment:** 2, 4, 6, 8, and 10 gauge; Bezel: 6, 8, and 10 gauge.

**No. 5 Assortment:** 8, 12, 14, and 18 gauge; Half-round: 6, 8, 12, and 14 gauge.

**No. 6 Assortment:** 8, 10, and 12 gauge; 3-Prong: 14 and 16 gauge;

**Four-Prong:** 16 and 18 gauge; Six-Prong: 16 gauge.



**Order # 21-02600**

Description	1+
No. 1 Round	\$22.70
No. 2 Round	\$14.70
No. 3 Rectangle	\$14.35
No. 4 Uncut Bezel	\$14.35
No. 5 Round	\$14.35
No. 6 Triangle	\$14.35

**WAX SHAPES**

- Solid Round
- Round Tube
- ◐ Solid Half-Round
- Solid Square
- Square Tube
- ▲ Triangle
- └ 90° Bezel
- Hinge Tube
- └ Channel
- Flat Ribbon
- └ Uncut Bezel
- Rectangle

**WAX CONVERSION CHART**

1 dwt	Multiply by	GAUGE/ MILLIMETER SIZE
Sterling Silver	10.36	1 Gauge/7.34 mm
10K yellow	11.60	2 Gauge/6.35 mm
14K white	12.65	3 Gauge/5.83 mm
14K yellow	13.08	4 Gauge/5.18 mm
18K white	14.65	6 Gauge/4.12 mm
18K yellow	15.60	8 Gauge/3.25 mm
Palladium	12.20	10 Gauge/2.6 mm
Platinum (10% Ir)	21.50	12 Gauge/2.06 mm
Platinum (5% Ir)	21.50	14 Gauge/1.6 mm
		16 Gauge/1.3 mm
		18 Gauge/1.0 mm
		20 Gauge/0.8 mm
		24 Gauge/0.5 mm

**STULLER SELECT CASTING WAX SHEETS**

High-grade, translucent, flexible casting wax sheets are used by jewelry designers for a wide variety of applications and are always pliable at room temperature. Each sheet measures four inches square. One Box = 32 sheets. Assortment Size: four 14-gauge, four 18-gauge, six 20-gauge, six 22-gauge, and six 24-gauge, six 26-gauge

**Order # 21-04400**

Wax Gauge	12+	6+	1+
14 Gauge	\$17.11	\$17.86	\$18.60
16 Gauge	\$17.11	\$17.86	\$18.60
18 Gauge	\$17.11	\$17.86	\$18.60
20 Gauge	\$17.11	\$17.86	\$18.60
22 Gauge	\$17.11	\$17.86	\$18.60
24 Gauge	\$17.11	\$17.86	\$18.60
26 Gauge	\$17.11	\$17.86	\$18.60
Assorted Gauges	\$17.11	\$17.86	\$18.60



**STULLER SELECT STICKY WAX**

A quick-setting adhesive that creates a rigid bond between two wax surfaces. This wax is a must when creating complex assemblies or attaching patterns to your sprue rod. Sticky wax will not hinder melt out, leaves no residue, and is ideal for both large and small parts. Melting temperature 161 degrees Fahrenheit.

Order #	Description	WxL	12+	6+	1+
21-0382	Stick	1/4"x5"	\$10.40	\$10.85	\$11.30
21-0383	Chunks (1 lb)	1/4"x5"	\$12.70	\$13.25	\$13.80





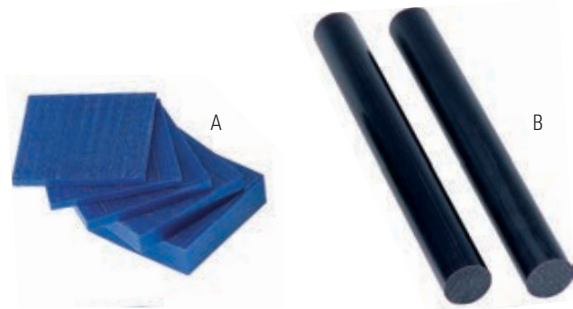

**STULLER FILE-A-WAX DESIGNER SHAPES BY FERRIS**

Stuller Select designer shapes provide a selection of basic shapes that are perfect for large, custom design work. These shapes afford the ability to respond quickly to design assignments or to creative inspirations. Available in blue (regular), green (hard), and purple (medium). Specify color when ordering.

**Order # 21-07100**

Item	Shape	Color	WxLxH	12+	6+	1+
A	Slices	Blue	5 3/16" x 5 3/16"	\$13.52	\$14.31	\$15.90
		Green	5 3/16" x 5 3/16"	\$13.52	\$14.31	\$15.90
		Purple	5 3/16" x 5 3/16"	\$13.52	\$14.31	\$15.90
B	Bar	Green	2 1/4" x 7 1/2"	\$13.43	\$14.22	\$15.80
		Purple	2 1/4" x 7 1/2"	\$13.43	\$14.22	\$15.80
		Blue	2 1/4" x 7 1/2"	\$13.43	\$14.22	\$15.80
		Green	1 5/16" x 11 1/4"	\$13.43	\$14.22	\$15.80
		Purple	1 5/16" x 11 1/4"	\$13.43	\$14.22	\$15.80
C	Half-Round	Green	4 5/8" x 3 1/8" x 2 5/8"	\$13.43	\$14.22	\$15.80
		Purple	4 5/8" x 3 1/8" x 2 5/8"	\$13.43	\$14.22	\$15.80
		Blue	4 5/8" x 3 1/8" x 2 5/8"	\$13.43	\$14.22	\$15.80
		Green	3 3/8" x 2 3/4" x 3 5/8"	\$15.68	\$16.61	\$18.45
		Purple	3 3/8" x 2 3/4" x 3 5/8"	\$13.43	\$14.22	\$15.80
D	Block	Green	3 3/16" x 3 3/16" x 2 3/8"	\$13.43	\$14.22	\$15.80
		Purple	3 3/16" x 3 3/16" x 2 3/8"	\$13.43	\$14.22	\$15.80

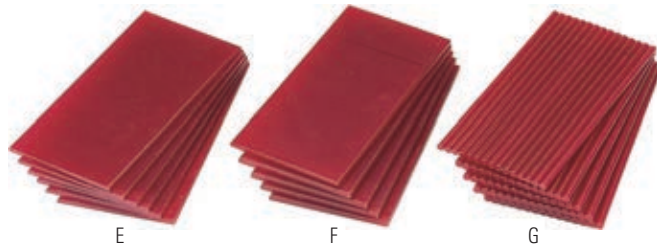
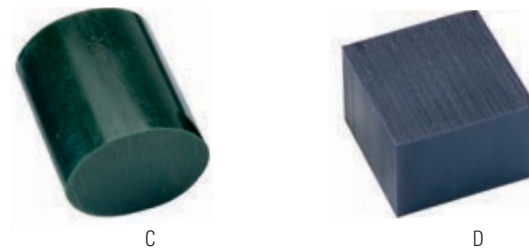

**STULLER FILE-A-WAX UTILITY WAX BY FERRIS**

Easily shaped waxes are specially suited for fill-ins and wax repair. Utility waxes can be used to easily correct mistakes or apply sprues to sprue bases. Pliable at room temperature.

**Order # 21-03920**

Item	Description	WxL	Thickness	Weight	12+	6+	1+
E	Thin	3" x 6"	1/8"	1/2 lb	\$8.10	\$8.45	\$8.80
F	Regular	3" x 6"	3/16"	1/2 lb	\$8.19	\$8.54	\$8.90
G	Sticks	3" x 6"	3/16"	8 oz	\$11.78	\$12.29	\$12.80



**STULLER FILE-A-WAX SLICE KIT**

**Half-Pound Kit Includes:** 1 3/16" H x 3/16" W wax sliced in thicknesses from 1/8" H to 1/4" W. Kit consists of: 6 pieces - 0.280" (7.1mm), 6 pieces - 0.200" (5.1mm), and 6 pieces - 0.135" (3.4mm).

**One-Pound Kit Includes:** 1 3/16"W x 3 5/8"L in thicknesses from 3/16" to 1". Each kit contains: one piece - 1" (25.4mm) thick; three pieces - 0.700" (17.8mm) thick; four pieces - 0.280" (7.1mm), four pieces - 0.190" (4.8mm), four pieces - 0.140" (3.6mm).

**Order # 21-02340**

Color	Net Weight	Per Pack	12+	6+	1+
Green	1/2 lb	18 slices	\$14.54	\$15.17	\$15.80
Purple	1/2 lb	18 slices	\$14.54	\$15.17	\$15.80
Blue	1/2 lb	18 slices	\$14.54	\$15.17	\$15.80
Green	1 lb	16 slices	\$15.00	\$15.65	\$16.30
Purple	1 lb	16 slices	\$15.00	\$15.65	\$16.30
Blue	1 lb	16 slices	\$15.00	\$15.65	\$16.30

**WOLF™ WAX RING TUBES AND SOLID BAR**

This carving wax melts at approximately 240 degrees Fahrenheit and is available in many sizes. It has medium hardness and flexibility and is ideal for extremely fine detail, piercing, and carvability.

**Order # 21-04760**

Item	Description	Color	WxL	12+	6+	1+
A	Ring Tube with Off-Center Hole	Gold	1 1/16" x 6"	\$9.56	\$10.13	\$11.25
B	Flat Top Ring Tube	Gold	1" x 6"	\$9.56	\$10.13	\$11.25
C	Flat Top Ring Tube (EH)	Gold	1 1/16" x 6"	\$10.35	\$10.80	\$11.25
D	Solid Ring Tube	Gold	1 1/16" x 6"	\$9.56	\$10.13	\$11.25
E	Ring Tube with Center Hole	Gold	1 1/16" x 6"	\$10.35	\$10.80	\$11.25

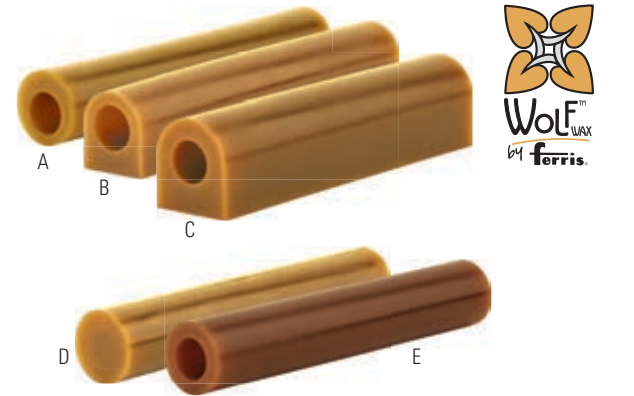

**WOLF™ WAX SPACE BLOCKS**

Order #	Color	WxL	Depth	Weight	12+	6+	1+
<b>21-0470</b>	Gold	3 3/16" x 3 3/16"	2 3/8"	1 lb	\$16.62	\$17.60	\$19.55



**WOLF™ WAX SLICE ASSORTMENT SET**

Order #	Color	WxL	Depth	12+	6+	1+
<b>21-0474</b>	Gold	1 7/16" x 3 3/8"	1/8 to 1"	\$16.62	\$17.60	\$19.55



**WOLF™ WAX BUILD-UP/REPAIR WAX**

This durable repair wax makes it easy to blend built-up and repaired sections. To ensure thorough bond, melt model where repair wax is to be added.

Order #	Color	WxL	Depth	Weight	12+	6+	1+
<b>21-0486</b>	Gold	3 3/4" x 1 3/16"	1 3/16"	3 oz	\$9.61	\$10.17	\$11.30



**WOLF™ WICKED STICKY POSITIONING WAX**

Ideal for securing stones for accurate tracing, just smear wax on stone, press stone onto the wax or metal, and scribe around the stone.

Order #	Shape	Length	Depth	Flow	12+	6+	1+
<b>21-0488</b>	Square	5"	3/16"	173°F (78°C)	\$16.75	\$17.73	\$19.70



**WOLF™ WAX**

Wolf wax is ideal for creating raised detail on carving waxes, the final touch-up of wax imperfections such as pits and cracks, or flow inside bezel walls for a tighter fit. Apply molten relief wax onto surface of the wax model. Can be easily carved. Touch-up wax can be easily scraped off for a smooth finish.

Item	Order #	Description	Flow	Weight	12+	6+	1+
F	<b>21-0489</b>	Touch-Up Wax	163° F (73° C)	1.7 oz	\$15.05	\$15.93	\$17.70
G	<b>21-0490</b>	Relief Wax	163° F (73° C)	1.7 oz	\$15.05	\$15.93	\$17.70





**KERR® INLAY WAX**

Superior build-up wax is excellent for repairing. Inlay wax has excellent carvability without chipping or flaking. Solidifies at 144 degrees Fahrenheit (62.2 degrees Celsius). Melting point 163 degrees Fahrenheit (72.8 degrees Celsius).

Order #	Outside Diameter	Length	12+	6+	1+
21-0250	¼"	3"	\$14.67	\$15.31	\$15.95

Great with synthetic paraffin wax.



**KERR® DISCLOSING WAX**

A creamy wax is used to repair wax pattern defects. Low melting temperature. Detects high spots and fills voids in waxes. Applies easily with wax tools or finger.

Order #	Description	Size	12+	6+	1+
21-0256	Repair Wax	2 oz	\$30.36	\$31.68	\$33.00



**KERR® PERFECT PURPLE**

Excellent build-up wax carves easily. Use especially when multiple layers of build up is required. Produces smooth surfaces. Melting point 156 degrees Fahrenheit (68.9 degrees Celsius).

Order #	Description	W×L×H	12+	6+	1+
21-0255	Build-Up Wax	1"×3"×1"	\$28.47	\$29.71	\$30.95



**SCULPTURE WAX STRIPS**

Soft, pliable wax is easily formed and shaped by hand without the use of heat. Perfect for forming large models.

Order #	Description	W×L×H	12+	6+	1+
21-6550	Sculpture Wax	¼"×24"×¼"	\$17.80	\$18.58	\$19.35



**DOUBLE-END WAX CARVER SET**

Seven excellent professional tools offer design versatility and a hardwood stand that includes a sharpening stone.

Order #	Description	Length	1+
21-1127	Carvers Set with Stand	6"	\$29.00
52-1012	Hardwood Stand	6"	\$10.65

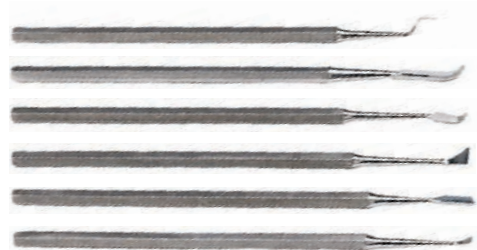

**WAX CARVER SET**

Made of high-grade, non-corrosive stainless steel, this wax carver set features all new shapes that cut or scrape waxes. Various tip designs give you the ability to work in tight places. Ergonomic handles provide a firm but pleasant grip. All tips feature sharp edges to cut properly.

Order #	Description	Length	1+
21-1125	Wax Carvers (6-Pieces)	6"	\$23.25

**WAX CARVING TOOLS**

Set contains four shapes with two sizes of each. Allows the user to actually carve the wax rather than scrape it away since the loops are sharp on one edge. Use to make and smooth designs or with wax lathes for making rings. Made of surgical-grade stainless steel with a sure-grip handle.

Order #	Description	1+
21-1100	Wax Carving Tools (4-Pieces)	\$24.00



**WAX DETAILER SET**

An excellent tool for filing waxes, points are stainless steel and spiral with file-like edges. They are small enough to file in tiny corners, crevices, and holes where other tools and files cannot reach. Set includes a fine detailer and an extra fine detailer. The fine detailer has a 1.2mm shaft, and the extra fine has a 0.8mm shaft. Comfortable wood handle measures four inches. Made in the USA.

Order #	Description	Length	1+
21-1000	Wax Detailers (2-Pieces)	5"	\$12.00



**WAX CARVERS AND PROBES**

This set of six popular carvers and probes for wax work is ideal for design and touch up. Made of stainless steel.

Item	Description	Length	1+
A	#3 Carver	6½"	\$6.35
B	#17 Probe	5¾"	\$3.25
C	#6 Probe	5½"	\$3.25
D	#5 Carver	6½"	\$6.35



**WALLER SCRIBER**

Use to scribe hard metal, glass, and stone. Reversible ends offer protection while carrying.

Order #	Description	Length	1+
52-9500	Scriber	6"	\$6.60



**DOUBLE-ENDED STEEL TRACER**

Twisted center allows firm grip. Ends are finely honed. Overall length is 6½".

Order #	Description	Length	1+
52-9660	Tracer	6½"	\$9.50







**STARRET DIVIDER**

Highly-polished dividers are made of spring steel with hardened, tempered, and well-balanced round legs. Floating washer and thumb screw permit fast and positive adjustment.

Order #	Description	1+
21-1128	Divider with 3 inch legs	\$75.00



**SPRING DIVIDER**

Features heavy-duty spring action with a special quick-adjustment nut. This is the perfect tool for measuring distances between points and scribing circles and arcs. Made in Germany.

Order #	Max Opening	Leg Length	1+
35-0800	2¼"	3"	\$14.35
35-0802	6½"	6"	\$15.50



**SPRING DIVIDER WITH ADJUSTABLE POINTS**

Sharp, pointed tips are adjustable and can be replaced. Maximum opening 2¾" with tips retracted or 3¼" with tips extended. Special quick-adjustment nut and heavy-duty spring. Made in Germany.

Item	Order #	Description	1+
A	35-0805	Spring Divider	\$14.35
B	35-0806	Replacement Tips (sold per pair)	\$2.65



**KERR® CALIPER**

Stainless steel and calibrated in 0.1mm, this caliper is excellent for measuring wall thicknesses. Rounded tip caliper works well for wax carving.

Order #	Description	1+
21-0025	Round Tip Caliper	\$37.50



**MAX WAX PENS**

Cordless wax tools are used to form beads and details, whisk away flares, and spray and repair floaters and accidents. Designed to transfer wax to models, this pen heats up instantly to 850 degrees with finger pressure control. Batteries included.

Item	Order #	Description	Length	Batteries	1+
C	21-2600	Max Wax Pen	6¾"	1- AA	\$25.00
D	21-2602	Super Max Wax Pen	8½"	2- AA	\$27.50
E	21-2601	Replacement Tips			\$6.60

**GILES WAXER**

This unit is excellent for carving, shaping, and texturing wax models. Comes with three tips and nine settings. Has a flexible handle for delicate work. Unit is 115V.

**Order # 21-00800**

Item	Description	1+
A	Waxer with 3 Tips	\$175.00
B	Replacement Tip (Blue)	\$14.45
C	Replacement Tip (Red)	\$14.90
D	Replacement Tip (Yellow)	\$14.45
E	Replacement Standard Handle	\$75.40
F	Handle for Heavy Duty Waxer	\$119.95

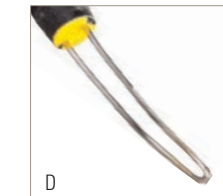
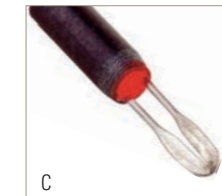
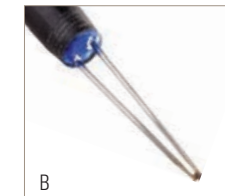

**KERR® ULTRA-WAXER 2**

An electronic waxing unit designed to increase efficiency and quality of waxing applications.

- Includes dual spatulas to optimize productivity and an all-aluminum, lightweight design, which helps increase user comfort.
- Foam grips on the spatula allow technicians to change the tips while they are still hot.
- A convenient tip holder that keeps eight interchangeable heating tips organized and easily accessible.
- Easy-to-use operations such as programmable presets and a quick heat function to increase unit effectiveness.
- Tips from your Ultra-Waxer will fit the Ultra-Waxer 2.
- 100 degrees Fahrenheit to 500 degrees Fahrenheit

**Order # 22-00850**

Item	Description	1+
C	Kerr® Ultra-Waxer 2	\$375.00
D	Spatula Small Blue Tip	\$79.80
E	Spatula Large Teal Tip	\$79.80
F	Spatula Beavertail Purple Tip	\$79.80
G	Spatula Small # 7 Gray Tip	\$79.80
H	Spatula Large # 7 Green Tip	\$79.80
J	Spatula Needle Red Tip	\$79.80
K	Spatula ½ Hollenback Black Tip	\$79.80
L	Spatula Small Denture Pink Tip	\$79.80
M	Spatula Large Denture Orange Tip	\$79.80
N	Spatula Denture Spoon Yellow Tip	\$79.80
P	Spatula Cord/Handle	\$79.80



Find added video content on [Stuller.com/VideoCenter](http://Stuller.com/VideoCenter).



Three tips included.

**FOREDOM® WAX CARVER**

**The Handpiece** — Lightweight and comfortable to hold with cork insulation to keep fingertips cool while working.

**Compact Control** — Precision heat-control dial for setting and maintaining temperatures from 95 degrees Fahrenheit (35 degrees Celsius) up to 560 degrees Fahrenheit (294 degrees Celsius). Only 2½" x 2" (64 x 51mm). It hardly takes up any workbench space. 115V.

**Brass Tips** — Easy to clean and change, they're a great improvement over the tips used on other models. You can alter the tips with a file or pliers and create your own custom shapes. The wax carver comes with three tips: knife, small spoon, and straight taper. Four optional tips are sold separately. One-year limited manufacturer's warranty on all components except tips.

Order # 21-01800

Item	Description	1+
A	Wax Carver	\$280.48
B	Knife Tip	\$12.50
C	Small Spoon Tip	\$12.50
D	Straight Taper Tip	\$12.50
E	Curved Taper Tip	\$12.50
F	Small Flat Tip	\$12.50
G	Large Flat Tip	\$12.50
	Replacement Handle for Wax Pen	\$103.00
	Replacement Cord	\$23.50

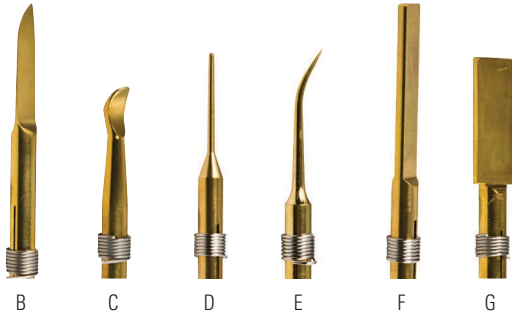

B C D E F G



**PRECISION WAX HEATING UNIT**

Heavy-duty variable power rheostat enables precise and consistent temperature control. Sturdy handle with ultra flexible cord provides comfortable use. Built-in holder provides a safe place to store handpiece when not in use. 100 degrees Fahrenheit-1200 degrees Fahrenheit.

Order # 47-41600

Item	Description	WxDxH	1+
H	Heating Unit with Tip	4"×6"×3"	\$145.00
J	Handpiece		\$45.00
K	Tip (Blue)		\$12.15
L	Tip (Red)		\$12.15
M	Tip (Yellow)		\$11.55
N	Tip (Orange)		\$11.55
P	Tip (Green)		\$12.15



J

K

L

M

N

P

**GRIFFITH WAXOLVENT**

A quality solvent and polish for wax and plastic models. Hazardous material ships UPS Ground only.

Order # 54-90100

Item	Description	Capacity	12+	6+	1+
A	Bottle	4 oz	\$6.21	\$6.48	\$6.75
B	Bottle	8 oz	\$10.26	\$10.70	\$11.15

**WAX KLEEN**

A non-petroleum, pleasant, citrus-scented solution for removing light scratches, parting lines, and polishing wax patterns. Also excellent for removing "stuck on" price or stock number labels without marring product surface. Ships UPS Ground only.

Order # 21-01600

Item	Description	Capacity	12+	6+	1+
C	Wax Gloss	4 oz (120 ml)	\$8.69	\$9.07	\$9.45
D	Wax Gloss	8 oz (120 ml)	\$15.18	\$15.84	\$16.50

**PRO-CRAFT® VAC-U-COAT/DEBUBBLER**

Reduces surface tension on model so that investment will adhere. Eliminates bubbles.

Item	Order #	Capacity	12+	6+	1+
E	54-4427	7½ oz	\$5.20	\$5.42	\$5.65

**MICRO WAX FILM DEBUBBLER**

Apply to wax patterns before vacuum investing to prevent wax bubbles. Non-flammable and biodegradable.

Item	Order #	Capacity	12+	6+	1+
F	54-4445	1 gallon	\$18.83	\$19.94	\$22.15

**DENATURED ALCOHOL**

For use in alcohol lamps, making anti-oxidizers, and as a quick-drying dip to prevent spotting of plated pieces. Flammable. Ships UPS Ground only.

Order # 54-80410

Item	Capacity	12+	6+	1+
G	16 oz bottle	\$6.85	\$7.15	\$7.45
	32 oz bottle	\$8.83	\$9.22	\$9.60
	1 gal bottle	\$28.11	\$29.33	\$30.55

**GLASS ALCOHOL LAMPS**

E-F. Nickel-plated brass burner with screw adjustment for wick. Includes three inch wick, 3/16" G. Nickel-plated brass burner with screw adjustment for wick. Includes three inch wick, 3/16"

Order # 54-80250

Item	Capacity	WxH	12+	6+	1+
H	1½ oz	2½"×1"	\$8.18	\$8.87	\$9.85
J	3 oz	2½"×1¾"	\$8.37	\$8.87	\$9.85
K	3 oz	3"×3"	\$17.43	\$18.19	\$18.95
	Replacement Wicks 3/16" (pack of 12)		\$3.69	\$4.01	\$4.45

**SOLVENT DISPENSER**

These dispensers have no stopper or cap to remove. Just touch the dispensing dish with a brush, cloth, or other applicator and the solvent is brought to the surface the instant it is needed. Stainless steel valves seal contents in the bottle until used, preventing spills, dripping, and escaping fumes. Fluid pumped into the dish does not drip back into the bottle, keeping stored liquids uncontaminated. Made of static dissipative plastic with Teflon tube.

Order # 54-40360

Item	Description	Capacity	12+	6+	1+
L	Small	4 oz (120 ml)	\$16.19	\$16.90	\$17.60
M	Small Anti-Splash	4 oz (120 ml)	\$16.70	\$17.42	\$18.15
N	Large	6 oz (180 ml)	\$16.19	\$16.90	\$17.60







**CASTALDO® MOLD RUBBER**

**Castaldo Gold Label®:**

- Premium soft
- Very pliable
- Great for molds containing undercuts

**Castaldo White Label®:**

- Regular Firm
- Resilient
- Pliable
- Great for pieces that do not require undercuts like flat items

**Castaldo No-Shrink Pink®:**

- Provides zero shrinkage
- Excellent detail
- Vulcanized at 310°F for 7½ minutes per layer.

**Order # 22-58500**

Item	Description	W×L	Thickness	12+	6+	1+
A	Gold Label Strips	27/8"×18"	1/8"	\$45.36	\$47.33	\$49.30
B	White Label Strips	27/8"×18"	1/8"	\$43.42	\$45.31	\$47.20
C	No-Shrink Pink Strips	27/8"×18"	1/8"	\$49.77	\$51.94	\$54.10
D	Gold Label Ready-Cut	27/8"×17/8"	1/8"	\$50.69	\$52.90	\$55.10
E	White Label Ready-Cut	27/8"×17/8"	1/8"	\$44.44	\$46.37	\$48.30
F	No-Shrink Pink Ready-Cut	27/8"×17/8"	1/8"	\$53.27	\$55.58	\$57.90



**CASTALDO® TITANIUM LABEL™ MOLD RUBBER**

**Castaldo Titanium Features**

- Less pattern distortion
- Higher injection pressures
- Reduced rubber shrinkage
- Lower injection temperatures
- Higher clamping pressure
- Better detail
- Vulcanized at 307 degrees

**Order # 22-5916**

Order #	Description	W×L	Thickness	12+	6+	1+
22-5916	Titanium Label	27/8"×18"	1/8"	\$49.31	\$51.46	\$53.60



**CASTALDO® SUPERSTRETCH SILICONE MOLDING RUBBER**

New SuperStretch offers fantastic tear strength that allows mold makers to make standard two-part molds of designs that formerly required complicated multipiece molds with difficult cores and inserts. The rubber stretches 900% before breaking. SuperStretch is easy to pack, easy to cut, and requires no silicone mold release spray. The shine is fantastic with waxes coming out with a glossy high shine finish meaning castings will require less finishing. Rubber shrinkage is very low at only 1.3%.

**Order # 22-5856**

Order #	Description	W×L	Thickness	12+	6+	1+
22-5856	Super Stretch	27/8"×18"	1/8"	\$45.36	\$47.33	\$49.30



**CASTALDO® ECONOSIL ORANGE SILICONE RUBBER**

Silicone molding rubbers are synthetic rubber compounds. They have the consistency of molding clay, which reduces packing time to a few minutes. No spray needed. The rubber is orange in color. Vulcanize at 330 degrees Fahrenheit for 15 minutes per layer.

**Order # 22-5900**

Order #	Description	W×L	Thickness	12+	6+	1+
22-5900	Silicone Mold Rubber	27/8"×18"	1/8"	\$45.36	\$47.33	\$49.30

**CASTALDO® GELATO™**

Castaldo super high strength silicone molding rubber cuts like butter. It resists tearing and is strong enough to make complex molds that are stronger than any other silicone molding rubber on the market. The different colors do not have different properties. Rather, they allow the jeweler to color code his/her molds for categorizing.

- Easy to cut
- No mold release spray
- High shine finish
- Cheaper and easier than RTVs
- Vulcanize at 330 degrees Fahrenheit for 15 minutes per layer
- Width x Length x Thickness: 27/8" x 18" x 1/8"

**Order # 22-59010**

Item	Color	W×L	Thickness	12+	6+	1+
A	Blue	27/8"×18"	1/8"	\$44.34	\$46.27	\$48.20
B	Peach	27/8"×18"	1/8"	\$44.34	\$46.27	\$48.20
C	Lemon	27/8"×18"	1/8"	\$44.34	\$46.27	\$48.20
D	Fuchsia	27/8"×18"	1/8"	\$44.34	\$46.27	\$48.20
E	Pistachio	27/8"×18"	1/8"	\$44.34	\$46.27	\$48.20
F	Violet	27/8"×18"	1/8"	\$44.34	\$46.27	\$48.20
G	Tan	27/8"×18"	1/8"	\$45.36	\$47.33	\$49.30
	Assorted - 7 colors	27/8"×18"	1/8"	\$44.34	\$46.27	\$48.20



**RAPIDO® JEWELRY MOLDING RUBBER**

Rapido® is a L.T.V.(low temperature vulcanization) silicone mold rubber that has a very fast vulcanizing time of 15 minutes at 200 degrees Fahrenheit for a 3/4" frame (versus 45 minutes of other L.T.V.s). Produces highly detailed wax injections with extraordinary surface quality with no need for mold release spray. Shrinkage is only 0.1%.

**Order # 22-5917**

Order #	Description	W×L	Thickness	12+	6+	1+
22-5917	Rapido® Jewelry Molding Rubber	3×18	1/8"	\$41.91	\$44.37	\$49.30



**CASTALDO® VLT SILICONE RUBBER**

Castaldo® VLT (very low temperature) make high volume molds directly from CAD/CAM and rapid prototyping models fast without risk of damage from heat or pressure. Get your models into production in as little as 30 minutes. Castaldo VLT vulcanizes at temps as low as 150 degrees Fahrenheit. Makes great molds from traditional wax carvings. Also, spray wax or plastic model with release spray to ensure easy release of the model after vulcanization. Shrinkage is only 1.4%. Castaldo Silicone Modeling Rubber can be vulcanized in a wide range of time and temperature combinations depending on the characteristics of your model material.

**Order # 22-5915**

Order #	Description	W×L	Thickness	12+	6+	1+
22-5915	Silicone Rubber	27/8"×18"	1/8"	\$41.91	\$44.37	\$49.30



**CASTALDO® LIQUAGLASS KIT**

Castaldo LiquaGlass is a 0% shrinkage, clear liquid RTV jewelry molding rubber that makes strong, tough, flexible production molds at only a fraction of the price of clear silicone rubbers. Easy to measure, easy to mix, easy to pour, and easy to vacuum or de-bubble, LiquaGlass cures at room temperature in 24 hours with 0% shrinkage. Castaldo LiquaGlass is packaged in a one-kilogram (2.2 pounds) kit containing equal parts A and B. 1:1 Mix Ratio. Cure time: 16 hours.

**Order # 22-5869**

Order #	Description	12+	6+	1+
22-5869	2-Part RVT Rubber Kit	\$59.59	\$63.09	\$70.10







**CASTALDO® LIQUAFast™ ICE**

LiquaFast™ ICE from CASTALDO® is a transparent, two-part, 0% shrinkage RTV silicone molding rubber that cures very rapidly at normal room temperatures and cures even faster at slightly warmer temperatures. That means that you can make a mold from your CAD CAM, RP, and SLA models in the morning, shoot waxes 30 minutes later, and cast them that afternoon. No more waiting. LiquaFast™ ICE makes strong, tough, tear-resistant permanent molds that last and last and do not become soft with age. LiquaFast™ ICE works well with all RP types, including hard-to-mold Solidscape® designs. LiquaFast™ Ice's low viscosity makes it easy to measure, mix, and pour. Normal cure time is only 60 ? 90 minutes. Faster cure is possible at only 50 degrees Celsius/120 degrees Fahrenheit. LiquaFast™ ICE is economical, costing far less than traditional silicone RTV materials.

Order #	Description	12+	6+	1+
22-5868	Castaldo® LiquaFast™ Ice	\$50.07	\$53.01	\$58.90



**CASTALDO® LIQUACast™ LONG-LIFE RTV LIQUID MOLDING RUBBER**  
Castaldo LiquaCast Liquid Molding Rubber New 0% shrinkage liquid RTV rubber with all the advantages of regular Castaldo LiquaCast plus added strength, tear resistance, and firmness. Its extreme durability means that difficult molds last and are less likely to break or tear in use. Bright orange in color, it is packaged in plastic containers in two-part kits weighing 1 kg, 8 kg, and 20 kg. Cure time: 24 hours.

Order # 22-5896

Description	Size	1+
LiquaCast Molding Rubber	2.2 lb	\$182.10
LiquaCast Molding Rubber	17.6 lb	\$69.60



**CASTALDO® LIQUACast™ AND CASTALDO® QUICK-SIL™ KITS**

A. Castaldo LiquaCast makes stronger, tougher, and longer-lasting production molds than other RTVs. LiquaCast is easier to mix, easier to vacuum or debubble, and easier to pour. It's safe, easy to use, and produces the finest details. Instructions included. 10:1 mix ratio. Cure time: 18 hours.

B. Castaldo Quick-Sil is a revolutionary 0% shrinkage jewelry molding rubber material that makes tough, long-lasting production molds with a high shine. Instructions included. Cure time: 15 minutes.

Item	Order #	Description	Size	1+
A	22-5870	2-Part LiquaCast Kit	1 lb	\$40.20
	22-5870	2-Part LiquaCast Kit	10 lb	\$100.80
B	22-5871	2-Part Quick-Sil Kit	2.216 lb	\$70.10
	22-5871	2-Part Quick-Sil Kit	11 lb	\$278.55



**CASTALDO® MOLD-LOCK FORMERS**

Castaldo mold-lock formers are a convenient, easy way to make mold locks without cutting. These stamped brass cones will form locks to prevent molds from shifting during injection. Sold by the bag. Each bag contains approximately 150 pieces weighing approximately three ounces.

Order #	Description	12+	6+	1+
22-5889	Mold Lock Formers	\$15.69	\$16.37	\$17.05



**CASTALDO® MOLD RELEASE CREAM™**

Makes mold separation easier. Mold cream is a lotion and is more effective at separating a mold in half than using knives or powder. Vulcanized molds can be pulled open by hand. Mold cream is safe and nontoxic in plastic containers.

Order #	Description	Size	12+	6+	1+
22-5844	Mold Release Cream	1 oz	\$9.10	\$9.63	\$10.70

**CASTALDO® RESIN RELEASE SPRAY**

This resin release spray is a non-silicone, non- PTFE coating designed to release plastic resin and wax models from jewelry molds. The resin spray is non-flammable, non-explosive, natural, biodegradable, and is worker safe. Each can contains 340 grams.

Item	Order #	Description	12+	6+	1+
A	22-5849	Resin Release Spray	\$12.62	\$13.68	\$15.20

**SPIRITS MOLD RELEASE**

Allows a clean, smooth release of wax from the rubber mold. Do not use with Ditto products. Hazardous material, ships UPS Ground only.

Item	Order #	Description	12+	6+	1+
B	22-5840	Resin Release Spray	\$9.98	\$9.98	\$9.98

**CASTALDO® JEWELRY-MOLD RELEASE SPRAY**

Safe, non-toxic, long-lasting silicone spray used to prevent wax from sticking to molds, which helps eliminate broken patterns. Works well on rubber molds and metal molds. Spray a small amount onto the mold before injecting wax. Virtually odorless. Material is non-explosive and nonflammable. Contains no CFCs or VOCs. Hazardous material, ships UPS Ground only.

Order #	Description	12+	6+	1+
22-5845	Mold Spray Release	\$11.86	\$12.56	\$13.95

**FREEMAN JEWEL-SIL KITS**

A two-part component, room-temperature vulcanizing silicone rubber compound. Designed especially for mold making, it is an ideal rubber for reproducing intricate detail and maintaining close tolerances. It features low viscosity for easy pouring and excellent clarity and cutting ability. It features high tear strength and the ability to endure temperatures up to 350°F. 1% or less shrinkage rate.

Item	Order #	Description	Size	Color	12+	6+	1+
C	54-5602	2-Part Silicone Rubber	2.2 lb	Clear	\$50.97	\$53.18	\$55.40
D	54-5605	2-Part Silicone Rubber	1 Gallon	Clear	—	—	\$277.55



**REPLISIL CLEAR MOLD SILICONE RUBBER KIT**

Two A and B component silicone that pours and cures at an ambient temperature without any shrinkage. Available in clear 1.1kg. 9:1 ratio of A to B. Made in Germany.



Order #	Description	12+	6+	1+
22-5811	2-Part - Silicone Mold Rubber	\$68.91	\$71.90	\$74.90





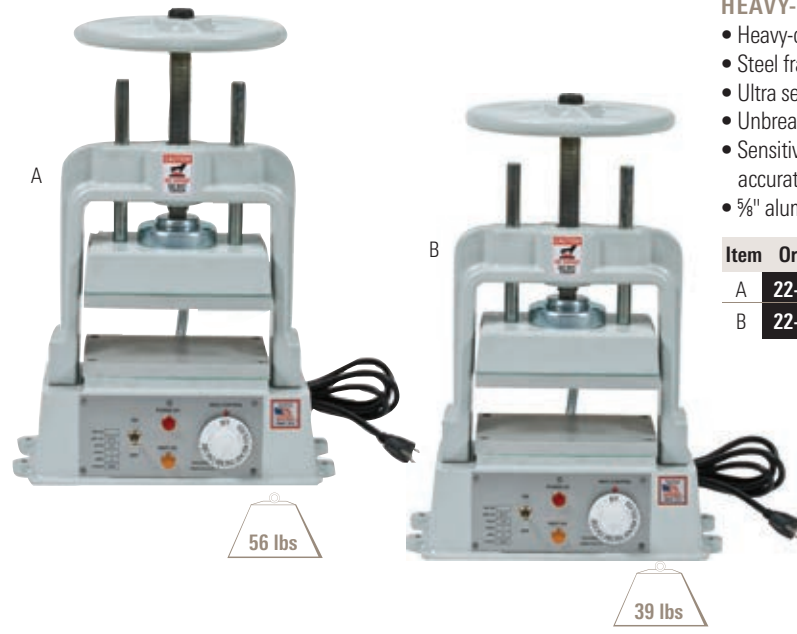

**HEAVY-DUTY VULCANIZERS**

- Heavy-duty aluminum cast construction
- Steel frame ceramic-mica heating element
- Ultra sensitive bulb and capillary
- Unbreakable yoke
- Sensitive thermostat ensures consistent, accurate temperature
- 5/8" aluminum heating plates won't warp
- Maximum Temperature: 550 degrees Fahrenheit
- Measures: 15"W x 18"H x 8"D
- Maximum Opening: Three inches
- Platen Measures: 5 x 8"
- 120V

Item	Order #	Description	W×L×H	ID	Jaw Size	1+
A	22-7436	Deluxe	15"×8"×18"	4"	6"×8¼"	\$750.00
B	22-7435	Standard	14"×9"×20"	2¾"	5"×8"	\$669.95



Shown closed.

56 lbs

39 lbs



**LIQUID MOLD FRAMES**

Clear plastic plates release easily from rubber and won't shatter or cut hands like glass plates. Plastic mold frames can be used with LiquaCast RTV liquid rubber compounds and all other liquid rubber compounds. Heavy-duty bands included.

Order # 22-60060

W×L	Thickness	12+	6+	1+
1½"×6"	1¼"	\$15.17	\$16.07	\$17.85
1½"×6"	1"	\$15.17	\$16.07	\$17.85
1½"×6"	1¼"	\$15.17	\$16.07	\$17.85
1½"×6"	1½"	\$15.17	\$16.07	\$17.85

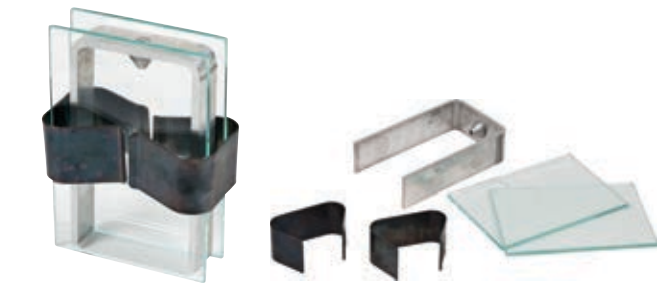

**SEE-THRU® MOLD FRAMES BY FERRIS®**

Features a built-in sprue former, glass cover plates, and corrosion resistant clamps. The perfect frame for pourable mold compounds.

Order # 22-59220

W×L	Thickness	12+	6+	1+
2"×3"	7/8"	\$17.55	\$18.59	\$20.65
2"×3"	¾"	\$17.98	\$19.04	\$21.15
2"×3"	1"	\$22.61	\$23.94	\$26.60
2"×3"	1¼"	\$22.36	\$23.67	\$26.30



**ALUMINUM MOLD FRAMES**

Used to hold uncured rubber and model when vulcanizing. Sides of frame contain pre-drilled holes to allow excess rubber to escape, preventing model deformation.

Order # 22-55060

W×L	Thickness	12+	6+	1+
2½"×17/8"	¾"	\$9.48	\$10.04	\$11.15
2½"×17/8"	1"	\$10.71	\$11.34	\$12.60
3¾"×2½"	1"	\$13.73	\$14.54	\$16.15
4¾"×3½"	1¼"	\$29.88	\$31.64	\$35.15

**MOLD FRAME PLATES**

Metal plates are used when vulcanizing to prevent mold rubber from adhering to the vulcanizer.

Order # 22-57000

W×L	Thickness	12+	6+	1+
5"×7"	1/8"	\$9.65	\$10.22	\$11.35
4"×6"	1/8"	\$7.61	\$8.06	\$8.95
3½"×5"	1/8"	\$5.95	\$6.30	\$7.00
2½"×3½"	1/8"	\$5.48	\$5.81	\$6.45



**SPRUE FORMERS**

Use to form an opening in the mold through which wax is injected. Attaches to the model in the mold frame. Also assures proper fit on the nozzle of the wax injector.

Order #	Description	12+	6+	1+
22-5800	Sprue Formers	\$1.10	\$1.15	\$1.20



**SWANN-MORTON® KNIFE BLADES**

Swann-Morton® high-carbon knife blades are high-quality, precise (non-sterilized) blades for mold cutting. High carbon is sharper and lasts longer than stainless.

Order # 39-25800

Item	Description	Per Pack	12+	6+	1+
A	#11 Straight	Pack of 5	\$1.62	\$1.71	\$1.90
	#11 Straight	Pack of 100	\$22.10	\$23.40	\$26.00
B	#12 Curved	Pack of 5	\$1.57	\$1.67	\$1.85
	#12 Curved	Pack of 100	\$22.10	\$23.40	\$26.00



**MOLD-CUTTING KNIFE HANDLES**

Use for #11 and #12 blades. Excellent for cutting rubber molds or wax carvings. Contoured and very comfortable.

Order # 39-25600

Item	Description	12+	6+	1+
C	Steel	\$3.19	\$3.38	\$3.75
D	Blue Rubber PVC Grip	\$7.10	\$7.52	\$8.35
E	Contoured Plastic	\$5.53	\$5.85	\$6.50
F	Hollow Stainless Steel	\$6.12	\$6.48	\$7.20



**RETRACTAWAY SCALPEL**

The Retractable has a sleek, graphite-finished metal handle, offering the added safety of a hand-retractable blade mechanism. It is a highly versatile cutting tool, produced with designers, graphic artists, and model makers in mind.

Order #	Description	Per Pack	12+	6+	1+
39-2500	Scalpel with 2 Blades		\$12.16	\$12.87	\$14.30
39-2585	#11 Straight	Pack of 5	\$1.62	\$1.71	\$1.90





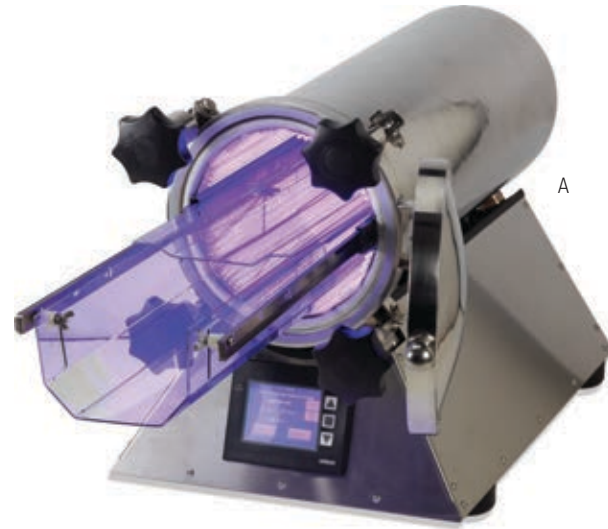

**HD EQUIPMENT**

A. **The HD Silver Bullet** is a hyperbaric curing chamber for HD photopolymer pattern production as well as RTV silicone mold making. This automatic hyperbaric chamber uses alternating air pressure and light energy to produce bubble-free HD precision casting patterns and bubblefree RTV silicone molds.

B. **The HD Firefly Kit** produces both silicone RTV molds and HD casting patterns. The Firefly hyperbaric light chamber utilizes air pressure instead of vacuum to eliminate air bubbles often associated with both mold and casting pattern production. Up to six RTV molds can be made in the chamber per cycle, curing in as little as two hours. When making HD casting patterns, up to four molds can be placed in the chamber per cycle with an average curing time of six minutes. Kit includes the hyperbaric light chamber, stainless steel stand, three stainless steel mold frames, timer, power supply, spin bag, and air coupling.

C. **The HD Pattern Micro Injector** is a pressure delivery system designed for easy dispensing or injecting of HD pattern photo polymers. The micro injector operates using a source of clean, oil and moisture-free, compressed air coupled to the units included air regulator. Luer style tip allows for easy change of the included gun tips.

All stainless steel construction and narrow foot print makes the unit practical in any manufacturing environment.

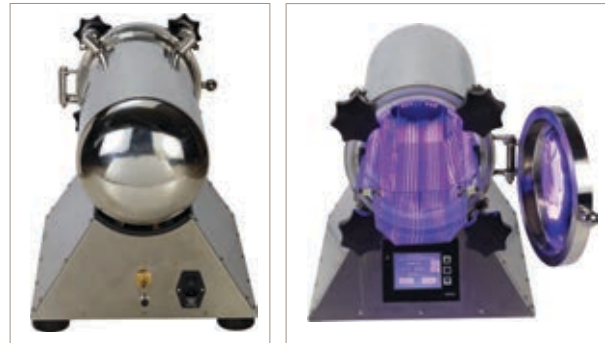

Item	Order #	Description	1+
A	54-5802	HD Silver Bullet	\$10,880.00
B	54-5803	HD Firefly Kit	\$688.00
C	22-5951	Small Injector	\$588.00



**HD MOLD FRAME**

HD Micro-Frame kits offer an economical alternative to traditional RTV mold frames. The compact frame sizes save approximately half the RTV required for industry standard frames. The precision stainless steel Micro- Frames quickly pay for themselves in RTV savings and are compatible with all RTV compounds. The innovative hinge-forming rod included in each kit allows the finished micro-molds to open and close like a book with perfect registration, eliminating the need for cutting intricate corner keys. A removable stainless steel sprue former and matching thumbscrew allows the master to be mounted in the sprue-former outside the mold frame without frame restriction or wobble. HD stainless steel micro-frame kits include two glass plates, rubber bands, sprue former, thumb screw, nylon hinge-forming rod, and nylon sprue-forming rod. The polypropylene jar that houses the kit doubles as a convenient RTV mixing cup.

Order # 22-59260

Description	Height	1+
HD Micro Mold Frame Kit	1/2"/12mm	\$19.85
HD Micro Mold Frame Kit	5/8"/16mm	\$20.95
HD Micro Mold Frame Kit	3/4"/20mm	\$22.00
HD Micro Mold Frame Kit	1"/25mm	\$23.05
HD Micro Mold Frame Kit	1 1/4"/31mm	\$24.05



**HD AVATAR**

Avatar is the newest addition to the HD Pattern System product line. Designed to produce heavier patterns in the class ring range for casting, this new photopolymer can also produce ultra light patterns as well. This virtual non-shrink polymer allows precise duplication from masters molded in clear RTV silicone. All HD patterns offer reliable detail and exact weights for casting. Patterns have perfect memory and infinite shelf life. A needed partner to CAD generated designs, HD patterns succeed where wax injection fails. One small bottle produces patterns that will yield up to 1,500 grams of 14 Karat gold castings.

Order # 22-5940

Description	Size	1+
Avatar	118ml	\$160.75
Avatar	405ml	\$423.25



Designed to produce heavier patterns in the class ring range for casting, this new photopolymer can produce ultra light patterns as well.



**HD MASTER COPY**

HD Master Copy is photopolymer that cures to a very tough and hard plastic that can be detailed and/or duplicated to produce a moldable master pattern. It's heat resistance allows it to be used as an alternate to the traditional silver masters for press molding with many vulcanized rubber molding materials, or as a master that can be used with silicone RTV molding compounds. -Detailing: Milled, injected, or hand carved waxes, as well as RP patterns, or metal masters, can be molded first in clear silicone RTV and a duplicate pattern can then be made with Master Copy. Once the Master Copy pattern is removed from the mold it can be post cured to achieve maximum hardness with the curing lights of the Silver Bullet or Firefly units or in strong sunlight. This first generation Master Copy can be detailed as if it were a metal casting with rotary tools, files, fine abrasives, engravers, and polished to produce a perfect finished master to be molded again. Minimal shrinkage will be present in the duplicate master and it can be saved and reused like a Silver Master to produce additional production molds.

Order #	Description	Size	1+
22-5941	HD Master Copy	118ml	\$160.75



Note: Before molding a Master Copy model, clean the model in soapy water. Post curing or mold release maybe required before the model is used with some molding compounds.





**STULLER MINI WAX INJECTOR**

This easy-to-use, economical, hand-operated pump injects wax into the mold. Thermostatically controlled settings keep wax at desired temperatures. Low temperature = 125 degrees Fahrenheit, Medium temperature = 150 degrees Fahrenheit, and High temperature = 175 degrees Fahrenheit. Available in 120V. One-year limited manufacturer's warranty. Made in the USA.

Order #	Description	W×H	Wax Capacity	1+
22-7425	1 Pint	8"×10"	1 lb	\$238.80

**STULLER AIR PRESSURE WAX INJECTOR**

The Stuller air pressure wax injector is a precision-engineered unit constructed to provide years of service-free performance. 2¾-quart capacity (5½ lbs wax), heavy-duty aluminum pot; large wing nuts for easy cover removal and wax loading; 0-20 PSI air pressure regulator and gauge; leak-resistant nozzle will not clog at injection temperature accurate thermostat and thermometer; on/off light; safety valve (set at 20 PSI); drain valve and provision for optional second nozzle. Available 120V, requires six to eight PSI (air supply not included). One-year limited manufacturer's warranty. 1100 Watt. Made in the USA.

Item	Order #	Description	W×H	Wax Capacity	1+
A	22-7432	2¾ Quart Wax Injector	9"×16"	5½ lb	\$470.00
REPLACEMENT PARTS					
B	22-7440	Complete Regulator Assembly			\$85.50
C	22-7437	Lid Seal			\$11.35
D	22-7439	Heating Element, 120V			\$91.55
E	22-7403	Nozzle Assembly			\$88.85
F	22-7431	Thermometer			\$28.10
	22-7438	Thermostat			\$92.30



1100 watt/6 amp

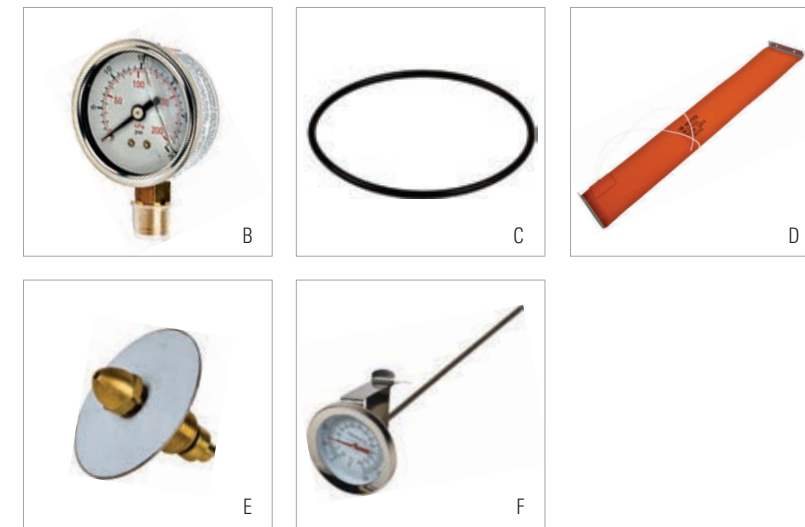

250 watts

**STULLER COMPACT AIR PRESSURE WAX INJECTOR**

The Arbe compact, air pressure wax injector is constructed to provide years of service-free performance. Heavy-duty, one-quart aluminum pot; three wing nuts for easy cover removal and wax loading; 0-20 PSI air pressure regulator and gauge; leak-resistant nozzle (will not clog at injection temperature; accurate thermostat; on/off, safety valve (set at 20 PSI). Requires six to eight PSI (air supply not included). One-year limited manufacturer's warranty. 250 Watt. Made in the USA.

Item	Order #	Description	W×H	Wax Capacity	1+
A	22-7424	1 Quart Compact Wax Injector	6"×12"	2½ lb	\$365.00
REPLACEMENT PARTS					
B	22-7440	Complete Regulator Assembly			\$85.50
C	22-7428	Lid Seal			\$11.55
D	22-7426	Heating Element, 120V			\$58.85
E	22-7403	Nozzle Assembly			\$88.85
F	22-7427	Thermostat			\$41.75



G

**ARBE WAX INJECTOR**

Ultra sensitive bulb and capillary thermostat ensure precise and consistent temperature control. Steel framed ceramic-mica heating elements. Double-sealed, no-leak nozzle features a convenient spigot drain allows easy cleaning and draining. Zinc-plated heavy-duty regulator with easy-to-read dial.

Item	Order #	Description	W×H	Wax Capacity	1+
G	22-7429	Arbe Wax Injector	10"×18"	4 lb	\$669.23





**INJECTION WAX FLAKES**

Freeman injection wax has been the industry standard for quality and consistency. Our formulations are renowned for their high pattern detail, rapid wax solidification, minimal shrinkage, excellent flow, and low ash content (0.003%), enabling the cleanest burnouts and most accurate reproductions possible. All are designed for platinum, gold, and silver, as well as industrial and dental alloys.

**AQUA FLAKES**

This all-purpose injection wax is our most popular formulation, as it provides the ideal balance of characteristics demanded by most designers and casters. Also recommended for stone in place casting.

Order #	Injection Temperature	12+	6+	1+
<b>21-0400</b>	150°F (65°C)	\$6.89	\$7.47	\$8.30

**RUBY RED FLAKES**

Similar to our Aqua Flakes except for the deep red color, many designers and casters prefer the darker color for easier visual verification of fine detail.

Order #	Injection Temperature	12+	6+	1+
<b>21-0401</b>	150°F (65°C)	\$6.89	\$7.47	\$8.30

**TURQUOISE FLAKES**

Similar to our Aqua Flakes except for the turquoise color, many designers and casters prefer the darker color for easier visual verification of fine detail.

Order #	Injection Temperature	12+	6+	1+
<b>21-0402</b>	150°F (65°C)	\$6.89	\$7.47	\$8.30

**FILIGREE PINK FLAKES**

This wax combines the flexibility of Tuffy Green with the excellent flow characteristics of Aqua Flakes, producing very high detail while enabling easy pattern removal without breakage. Recommended for stone in place casting.

Order #	Injection Temperature	12+	6+	1+
<b>21-0403</b>	155°F (68°C)	\$6.89	\$7.47	\$8.30

**FLEXIBLE BLUE FLAKES**

Featuring the longest shelf-life and highest flexibility of the Freeman Flakes line, this unique mixture of wax and plastic is especially well-suited for metal molds and stone in place casting.

Order #	Injection Temperature	12+	6+	1+
<b>21-0410</b>	155°F (68°C)	\$7.06	\$7.47	\$8.30

**CARVEABLE PURPLE FLAKES**

This wax features low shrinkage, excellent flow, and low ash content, yet offers minimal gumming of wax files and rotary tools like that of traditional injection waxes. It is a durable wax that will not break under stress and does not react to body heat from fingers while handling. Ideal for designers or any casters who find themselves often reworking wax patterns.

Order #	Injection Temperature	12+	6+	1+
<b>21-0016</b>	170°F (77°C)	\$7.06	\$7.47	\$8.30



	Flow	Flexibility	Carvability	Shrinkage	Memory	Pattern Shelf Life	Readability	Solidification Time
<b>Aqua</b>	High	Medium	Low	Low	Medium	High	High	Medium
<b>Ruby Red</b>	High	Medium	Low	Low	Medium	High	High	Medium
<b>Turquoise</b>	High	Medium	Low	Low	Medium	High	High	Medium
<b>Filigree Pink</b>	Medium	Medium	Low	Low	Medium	High	Medium	Medium
<b>Filigree Blue</b>	Medium	Highest	Medium	Medium	High	Highest	Medium	Medium
<b>Carveable Purple</b>	High	High	High	Low	Medium	High	High	Fast

**BEAD INJECTION WAXES BY FERRIS®**

Excellent flow and high flexibility, this tough wax yields bright surfaces and will not become brittle in storage. Contains a built-in release agent. Turquoise beads with the same durability as aqua, the darker color increases pattern readability. Injection temperature: 160 degrees to 165 degrees Fahrenheit (71 degrees to 74 degrees Celsius).

**Order # 21-04200**

Item	Description	12+	6+	1+
A	Turquoise-Ject Wax Beads	\$6.10	\$6.62	\$7.35
B	Aqua-Ject Wax Beads	\$7.47	\$8.10	\$9.00
C	Pink Magna-Ject Wax Beads	\$7.55	\$8.19	\$9.10

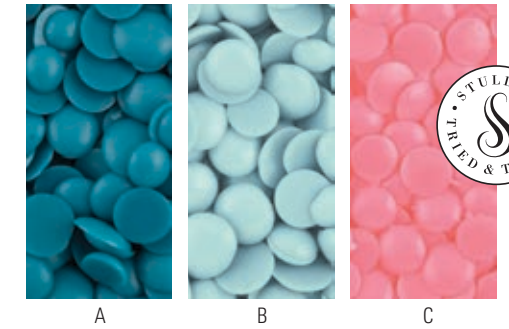

**CASTALDO® PLAST-O-WAX JEWELRY INJECTION WAX**

- Produces patterns that are very flexible, resilient, and durable with great memory.
- Patterns will not break despite rough handling.
- Patterns bend, flex, and twist under pressure but return to their original shape.
- Excellent flow and fill characteristics of wax and the stability of plastic.
- Wax does not become brittle over time. Inject them now. Use them months later.
- Wax releases easily from any type of mold to produce patterns with smooth glossy surfaces, crisp detail, and minimal shrinkage.
- Unlike plastic-only pattern materials, it can easily be steam de-waxed
- Injection temperature 155 degrees to 160 degrees Fahrenheit (68 degrees to 71 degrees Celsius).

Order #	Description	12+	6+	1+
<b>21-0429</b>	Injection Wax	\$23.67	\$25.07	\$27.85



**CASTALDO SUPERCERA GOLD**

Superior quality wax for a full range of applications in a unique, new form that provides extra convenience with easy identification. The Supercera Gold is a hard wax with very little flexibility. Flows easily and will hold sharp detail. Almost no shrinkage or shrink. Can be carved. Recommended for large patterns with fine detail. Good for metal molds. Inject at 70 degrees Fahrenheit (76 degrees Celsius).

Order #	Description	12+	6+	1+
<b>21-0460</b>	Supercera Gold	\$46.32	\$48.34	\$50.35







**STULLER SELECT WAX SPRUE RODS**

These are the ideal wax for sprue rods. Fully refined to eliminate impurities, the rods burn out quickly without expansion or residue. Perfect for building even the most demanding sprue systems. The sprue rod of choice for Stuller's own manufacturing. Light Green: A medium hard spruce rod which is tough and rigid. Perfect for general purpose casting. Melt 158°-168 degrees Fahrenheit

**Order # 21-13300**

Diameter	Length	Per Unit	12+	6+	1+
3/8"	10"	1 lb Pack	\$11.82	\$12.34	\$12.85
1/2"	10"	1 lb Pack	\$12.79	\$13.34	\$13.90
3/8"	6"	25 lb box	—	—	\$441.20

**SPRUE WAX**

Combines flexibility and sufficient rigidity for sprues and mounting wax patterns. Melts at lower temperature (125 degrees Fahrenheit) and burns out clean. Great for general sprues and creating runners.

**Order # 21-13050**

Gauge	Length	Per Unit	12+	6+	1+
6 Gauge	4"	2 oz box	\$9.21	\$9.99	\$11.10
8 Gauge	4"	2 oz box	\$9.21	\$9.99	\$11.10
10 Gauge	4"	2 oz box	\$9.21	\$9.99	\$11.10
12 Gauge	4"	2 oz box	\$9.21	\$9.99	\$11.10

**HEXAGON SPRUE WAX**

Six-sided wax rods make treeing for production casting faster and easier than traditional round sprue rods. Melting temperature 125 degrees Fahrenheit. Burns out fast and clean.

Order #	Diameter	Length	Per Unit	12+	6+	1+
<b>21-1383</b>	3/8"	24"	1 lb pack	\$5.40	\$5.72	\$6.35

**EXTRUDED SPRUE WAX**

Round, petroleum-based red wax rods (24-inch lengths) for sprues. Melting temperature 125 degrees Fahrenheit. Burns out quickly and cleanly.

Order #	Diameter	Length	Per Unit	12+	6+	1+
<b>21-0395</b>	1/4"	24"	1 lb pack	\$15.69	\$16.37	\$17.05
<b>21-0396</b>	3/8"	24"	1 lb pack	\$16.70	\$17.42	\$18.15

**KERR FLASKS**

Made of durable stainless steel, these 18-gauge flasks withstand extreme

Order #	Description	OD	Height	12+	6+	1+
<b>22-4720</b>	2C	1 3/4"	1 1/2"	\$15.69	\$16.37	\$17.05



**CASTING FLASKS**

Made of durable stainless steel. Withstands extreme temperatures, quenching, and burnouts. 18 gauge.

**Order # 21-69250**

Item	OD	Height	12+	6+	1+
A	2"	2 1/2"	\$4.19	\$4.37	\$4.55
B	2 1/2"	3"	\$5.29	\$5.52	\$5.75
C	2 1/2"	4"	\$5.98	\$6.24	\$6.50
D	3"	3"	\$6.21	\$6.48	\$6.75
E	3"	4"	\$6.62	\$6.91	\$7.20
F	3 1/2"	3"	\$7.87	\$8.21	\$8.55
G	3 1/2"	4"	\$7.91	\$8.26	\$8.60
H	3 1/2"	5"	\$10.49	\$10.94	\$11.40
J	4"	4"	\$10.49	\$10.94	\$11.40
K	4"	5"	\$9.95	\$10.53	\$11.70
L	4"	6"	\$11.87	\$12.38	\$12.90



**PERFORATED FLASKS**

Made of stainless steel, these flasks are used in vacuum casting. A vacuum pulls through the end and side, which allows complete fills. Masking tape is used to cover the holes when investing.

**Order # 21-70000**

Item	OD	Height	12+	6+	1+
L	2 1/2"	3 1/2"	\$17.30	\$18.32	\$20.35
M	2 1/2"	4"	\$21.93	\$23.22	\$25.80
N	3"	4"	\$25.63	\$27.14	\$30.15
P	3 1/2"	4"	\$25.42	\$26.91	\$29.90
Q	3 1/2"	5"	\$29.79	\$31.55	\$35.05
R	3 1/2"	6"	\$31.92	\$33.80	\$37.55
S	4"	4"	\$34.27	\$35.76	\$37.25
T	4"	6"	\$33.96	\$35.96	\$39.95
U	4"	7"	\$40.07	\$41.81	\$43.55
V	4"	8"	\$42.29	\$44.78	\$49.75
W	4"	8 1/2"	\$45.48	\$48.15	\$53.50

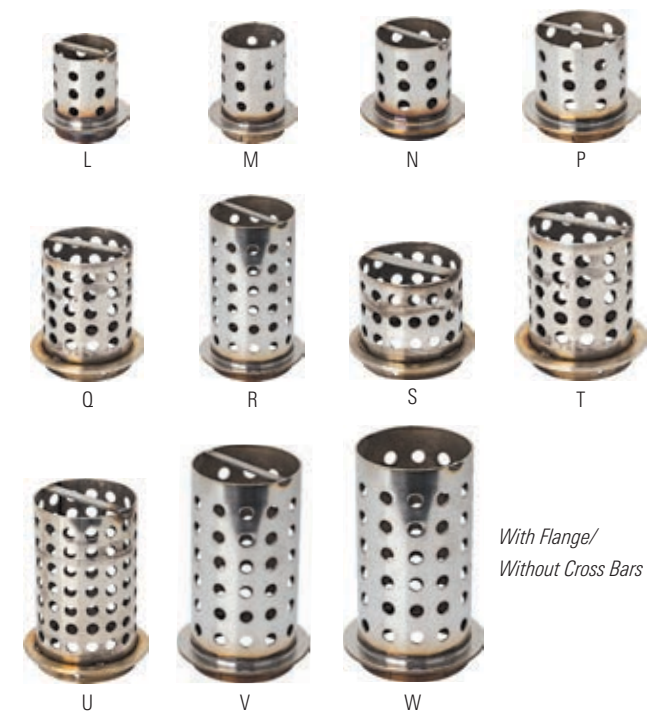

*With Flange/  
Without Cross Bars*

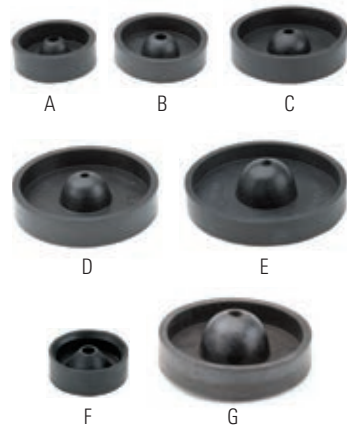

**SPRUE BASE**

Allows the tree rod to be placed directly in the base and held securely. Will accept 3/8" or 1/4" sprue rods.

**Order # 21-78350**

Item	OD	12+	6+	1+
A	2"	\$2.71	\$2.83	\$2.95
B	2½"	\$2.90	\$3.02	\$3.15
C	3"	\$3.13	\$3.26	\$3.40
D	3½"	\$3.59	\$3.74	\$3.90
E	4"	\$3.86	\$4.03	\$4.20

Item	Order #	OD	12+	6+	1+
F	<b>22-4725</b>	1¾"	\$9.38	\$9.79	\$10.20
G	<b>22-4727</b>	3¾"	\$4.23	\$4.42	\$4.60



**BUTTON SPRUE BASE**

Use to form the base for the sprue. Fill the cup in the center with wax or clay, and attach wax with sticky wax.

**Order # 21-78300**

Item	OD	12+	6+	1+
H	2"	\$2.94	\$3.07	\$3.20
J	2½"	\$2.99	\$3.12	\$3.25
K	3"	\$3.22	\$3.36	\$3.50
L	3½"	\$3.17	\$3.31	\$3.45
M	4"	\$4.28	\$4.46	\$4.65



**FLASK EXTENDERS**

Use to prevent overflow of investment during vacuuming. Made of rubber. Easily slips on and off flasks.

**Order # 21-79700**

Item	OD	Height	12+	6+	1+
N	2½"	3"	\$8.65	\$9.02	\$9.40
P	3"	3"	\$8.65	\$9.02	\$9.40
Q	3½"	3"	\$8.65	\$9.02	\$9.40



**RUBBER SLEEVES**

Use in place of masking tape to cover holes on the perforated flasks. Sleeves easily fit over flasks to contain investment while pouring. Remove sleeve prior to burnout.

**Order # 21-70100**

Item	OD	Height	12+	6+	1+
R	3¾"	4"	\$8.19	\$8.54	\$8.90
S	4"	5¾"	\$11.50	\$12.00	\$12.50
T	4"	7"	\$15.41	\$16.08	\$16.75

**PLATINUM FLASK LINER SHEET**

Order #	Description	WxL	Thickness	12+	6+	1+
<b>21-7976</b>	Flask Liner	8"×31"	¼"	\$12.24	\$12.96	\$14.40



**FLASK TONGS**

Steel tongs used for lifting small and large perforated flasks to and from oven.

Order #	Length	12+	6+	1+
<b>57-0680</b>	15"	\$5.70	\$6.03	\$6.70

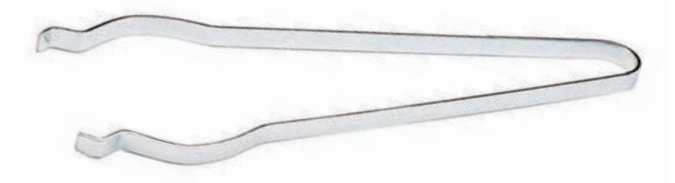

**ADJUSTABLE FLASK TONG**

Lightweight and practical, this flask tong can be adjusted to accommodate a four-inch, five-inch, or six-inch diameter flask.

Order #	Description	Length	12+	6+	1+
<b>22-7921</b>	Flask Tong	33"	\$122.27	\$129.47	\$143.85



**SPRING-ACTION FLASK TONG**

The spring action of this particular style flask tong enables the user to operate with one hand.

Order #	Description	Length	12+	6+	1+
<b>22-7922</b>	Flask Tong	25"	\$122.27	\$129.47	\$143.85



**CRUCIBLE TONG**

Heavy-duty tongs are designed to easily handle the pouring of crucibles.

Order #	Description	Length	12+	6+	1+
<b>22-7923</b>	Crucible Tong	34"	\$122.27	\$129.47	\$143.85





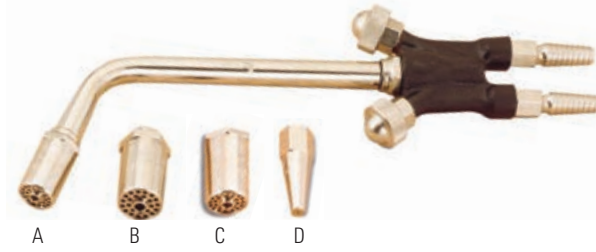

**HIGH-HEAT TORCH**

The mixing chamber of the Model D blowpipe is designed for use with natural, artificial, or bottled gas but not for acetylene. Produces an intense, perfectly formed flame. Use standard 1/2" hose with C-clamps.

Order # 54-45350

Item	Description	12+	6+	1+
A	Hi-Heat Torch	\$59.46	\$62.96	\$69.95
B	Large Gas/Air Torch	\$11.99	\$12.69	\$14.10
C	Small Gas/Air Torch	\$11.60	\$12.29	\$13.65
D	Oxygen/Gas Torch	\$6.80	\$7.20	\$8.00



**THE SWISS TORCH**

The most versatile, handy, lightweight, and reliable torch on the market. Use with propane and natural gas/oxygen. Not for use with acetylene. The selection of heads permit pinpoint to large flames for melting. 100% made in Switzerland.

Order # 14-16600

Item	Description	12+	6+	1+
E	Swiss Torch Body	\$101.15	\$107.10	\$119.00
F	Micro Head w/3 Needle Nozzles	\$133.07	\$140.90	\$156.55
G	Hoke Standard Head	\$133.07	\$140.90	\$156.55
H	Short Melting Head	\$98.73	\$104.54	\$116.15
J	Long Melting Head	\$98.73	\$104.54	\$116.15
K	Platinum Head	\$90.61	\$95.94	\$106.60



Used to help prevent dangerous reverse gas flow.

**CHECK VALVE**

Order # 14-17900

Item	Description	12+	6+	1+
L	For Fuel Gas Regulator	\$12.58	\$13.32	\$14.80
	For Oxygen Regulator	\$12.58	\$13.32	\$14.80



**CHECK VALVES/FLASHBACK ARRESTORS**

Stops flashback fires by preventing reverse gas flow with automatic reset between flashes. Solid brass case is durable and easy to install. Fits standard 1/16" B connections.

Order # 14-0769

Item	Description	12+	6+	1+
M	For Fuel Gas Lines	\$36.08	\$38.21	\$42.45
N	Oxygen Flashback Arrestor	\$36.08	\$38.21	\$42.45

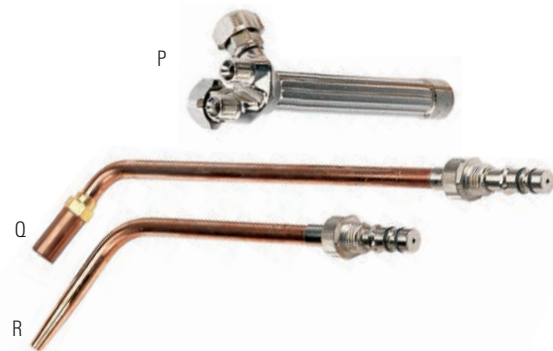

**SMITH CASTING TORCHES**

Smith torch handle is nickel plated. Use for casting platinum, gold, or silver. Note: Flashback arrestors recommended for use with all casting torches. UL listed with a lifetime warranty.

Order # 14-5060

Item	Description	12+	6+	1+
P	Smith Torch Handle	\$141.65	\$149.99	\$166.65
Q	Oxygen/Acetylene Heating Tip	\$85.26	\$90.27	\$100.30
R	Oxygen/Propane Tip	\$54.53	\$57.74	\$64.15

**MELTING DISH WITH HANDLE**

Ideal for torch melts, these removable wooden handle resists heat, which makes it easy to melt and pour metals.

Order # 22-79100

Item	Description	12+	6+	1+
A	Crucible	\$13.25	\$13.82	\$14.40
B	Crucible with Handle	\$20.88	\$21.79	\$22.70
C	Handle	\$6.58	\$6.86	\$7.15



**MELTING DISHES KITS**

Small crucible dish holder

Item	Order #	Description	12+	6+	1+
D	22-7913	Small Holder	\$9.38	\$9.79	\$10.20
	22-7913KIT	Small Kit	\$17.76	\$18.53	\$19.30
E	22-7914	Large Holder	\$10.49	\$10.94	\$11.40
	22-7914KIT	Large Kit	\$20.88	\$21.79	\$22.70

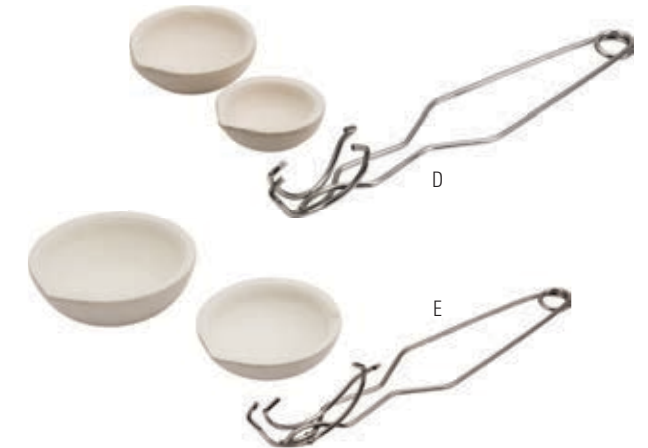

**CRUCIBLE DISHES**

Order # 22-79300

Item	Description	Diameter	Height	12+	6+	1+
F	16 dwt /148 g	1 3/4"	5/8"	\$4.05	\$4.22	\$4.40
G	19 dwt /196 g	2 1/4"	3/4"	\$4.19	\$4.37	\$4.55
H	25 dwt /155 g	3"	1"	\$6.21	\$6.48	\$6.75
J	35 dwt /420 g	4"	1 3/8"	\$5.43	\$5.66	\$5.90



**STRAIGHT SIDES MELTING DISHES**

Use for high-temperature (2,500 degrees Fahrenheit) melting of platinum, chromium, gold, alloys, and other metals.

Order # 22-79370

Item	Diameter	Height	Capacity	12+	6+	1+
K	3 3/8"	2"	18 oz/510 g	\$11.41	\$11.90	\$12.40
L	3 3/4"	3 1/2"	40 oz/1134 g	\$13.52	\$14.11	\$14.70



**MORGAN MELTING DISH (WESGO)**

Use for high-temperature melting of platinum, chromium, gold, alloys, and other metals.

Item	Order #	Description	Capacity	12+	6+	1+
M	22-8150	Straight Side	8 oz (227g)	\$22.36	\$23.33	\$24.30
N	22-8152	High Back	10 oz (282g)	\$25.62	\$26.74	\$27.85



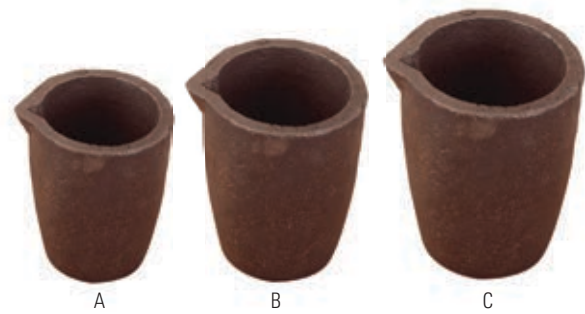

**GRAPHITE CRUCIBLES**

These heat-resistant crucibles, often called black lead, withstand temperatures up to 3,000 degrees Fahrenheit (1,649 degrees Celsius) and will tolerate thermal shock.

Order # 22-8000

Item	Diameter	Height	12+	6+	1+
A	5¼"	4¼"	\$28.70	\$28.70	\$28.70
B	4⅞"	3⅞"	\$34.50	\$36.00	\$37.50
C	6⅝"	5⅝"	\$51.20	\$53.42	\$55.65

**MELTING CRUCIBLES**

These melting crucibles have thick walls that will withstand temperatures up to 2,500 degrees Fahrenheit. Made of clay bonded fused silica, these heavy-duty crucibles have spouts (lips) for easy pouring. Use for torch welding only.

Order # 22-79420



Item	Diameter	Height	Capacity	12+	6+	1+
D	2⅝"	2⅞"	18 oz	\$9.38	\$9.79	\$10.20
E	3½"	3½"	45 oz	\$12.47	\$13.01	\$13.55
F	4"	4½"	80 oz	\$16.65	\$17.38	\$18.10
G	5"	5¼"	150 oz	\$22.68	\$23.66	\$24.65

**CRUCIBLES**

These crucibles are designed for use with the tabletop casting machine from Ti-Research.

Order # 21-70500



Item	Description	Max Capacity	12+	6+	1+
H	Medium	up to 150g	\$21.80	\$22.75	\$23.70
J	Large	up to 250g	\$24.56	\$25.63	\$26.70
K	Extra Large	up to 450g	\$28.61	\$29.86	\$31.10

**CASTING CRUCIBLES**

These crucibles for centrifugal casting machines are suitable for melting metals in temperatures up to 2,000 degrees Fahrenheit. Square casting crucibles retain heat and are excellent for use with centrifugal casting machines.



Item	Order #	Description	Capacity	12+	6+	1+
L	22-4620	Replacement Crucible	9 oz	\$20.88	\$21.79	\$22.70
M	22-4624	Round	9 oz	\$24.93	\$26.02	\$27.10
N	22-4631	Square	12 oz	\$17.80	\$17.80	\$17.80
P	22-4634	Square	18 oz	\$22.72	\$23.71	\$24.70

**KERR® CLAY CRUCIBLES**

These high-quality, clay/ceramic replacement crucibles are for melting gold, silver, and other non-ferrous metals. Use with centrifugal casting machines.

Item	Order #	Description	W×L	Capacity	12+	6+	1+
A	22-4700	Standard	1⅞"×1⅞"	1 oz	\$32.94	\$34.37	\$35.80
B	22-4701	Standard	1⅞"×2⅝"	2½ oz	\$27.19	\$28.37	\$29.55
C	22-4702	4" x 6"	1⅞"×3⅝"	7 oz	\$34.09	\$35.57	\$37.05



**PLATINUM CRUCIBLE**

Use only with the large Yasui platinum casting machine.

Order #	Description	Capacity	12+	6+	1+
22-3700	Large Crucible	400g	\$6.85	\$6.85	\$6.85



**MORGAN CRUCIBLES (WESGO)**

Use for high-temperature melting of platinum, chromium, gold, alloys, and other metals.

Order #	Description	Capacity	12+	6+	1+
22-4610	Slotted A	13 oz (185g)	\$30.82	\$32.16	\$33.50



**HOODED CRUCIBLE WITH SPOUT**

Hooded, high-temperature ceramic crucibles for steel.

Order #	Description	Capacity	12+	6+	1+
22-3702	500 DWT	110ml	\$17.89	\$18.67	\$19.45



**CRUCIBLE**

Crucible for casting gold and silver.

Order # 22-2165

Item	Description	OD×ID×Height	1+
D	Crucible for Steel Casting	2.2"×1.6"×2.9"	\$24.25
E	Crucible for Platinum	1.7"×1.5"×2.8"	\$100.50
F	Crucible for Gold and Silver	1.7"×1.1"×2.7"	\$32.35





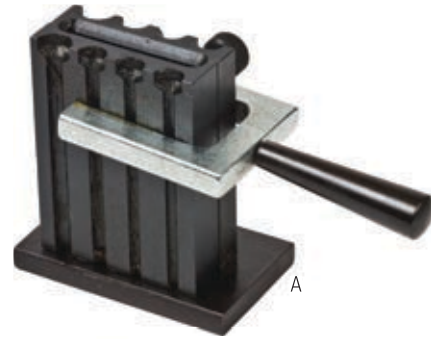

**REVERSIBLE INGOT MOLD**

Use to recycle scrap metal. One side makes sheet and the other side makes wire in three, four, five, and six-millimeter sizes. C-clamp secures and releases the plates.

Item	Order #	Description	Capacity	12+	6+	1+
A	22-8770	Wire and Sheet	130 dwt (221g)	\$42.63	\$45.14	\$50.15



Find added video content on [Stuller.com/VideoCenter](http://Stuller.com/VideoCenter).



**DURSTON REVERSIBLE INGOT MOLDS**

Precision ground. Six sizes of wire. Adjustable flat up to 70mm.

Item	Order #	Description	W×L	12+	6+	1+
B	22-8711	6 Hole	60mm×110mm	\$116.79	\$123.66	\$137.40
C	22-8712	Flat	50mm×130mm	\$107.31	\$113.63	\$126.25



**DURSTON OPEN INGOT MOLD**

Use to form ingots or bullion.

Item	Order #	W×L×H	Capacity	12+	6+	1+
D	22-8700	35mm×90mm×35mm	50 dwt (78g)	\$25.76	\$27.27	\$30.30
E	22-8701	35mm×90mm×35mm	80 dwt (124g)	\$29.50	\$31.23	\$34.70
F	22-8702	65mm×155mm×40mm	200 dwt (310g)	\$38.42	\$40.68	\$45.20

**DURSTON INGOT MOLD FOR WIRE**

Use to form metal into wire strips before rolling or drawing. Can make three sizes: 3/4" x 5/16" x 6 1/16" (19mm x 8mm x 170mm) 3/8" x 3/8" x 6 1/16" (9mm x 9mm x 170mm) 5/32" x 5/16" x 6 1/16" (7mm x 8mm x 170mm)

Item	Order #	W×L×H	12+	6+	1+
G	22-0510	1 1/4"×10 1/2"×1 1/4"	\$9.05	\$9.59	\$10.65

**BORAX**

Specially prepared for making flux for jewelry soldering. Dissolves easily to make a paste. Inhibits the formation of oxides on metal surfaces and allows solder to flow more easily.

Item	Order #	Description	Weight	12+	6+	1+
A	54-2520	Cone	4 oz	\$6.16	\$6.43	\$6.70

**MAGIC BORAX**

Borax Granular powder is an excellent, general purpose flux. Excellent for glazing clay crucibles to extend crucible life.

Item	Order #	Description	Weight	12+	6+	1+
B	54-4432	Boric Acid Granular	16 oz	\$7.41	\$7.73	\$8.05

**MAGIC BORIC ACID POWDER®**

High-grade, superfine boric acid powder. Use as high-grade flux and deoxidizing agent. Can also be mixed with denatured alcohol to make soldering flux.

Item	Order #	Description	Weight	12+	6+	1+
C	54-4433	Boric Acid Powder	16 oz	\$8.59	\$9.09	\$10.10

**FIRESCOFF®**

Revolutionary spray ceramic coating that prevents oxidation and scale, acts as a flux, and features easy removal with just warm water. With Firescoff, no additional pickle flux is required, and no pickle solution is needed. Protects gemstones from heat oxidation in multiple soldering operations without waiting; consistent void-free, non-brittle, welds. Ideal for jewelry manufacturers, repair jewelers, and stone setters. Non-flammable. Odor-free, alcohol-free.

Item	Order #	Container Volume	12+	6+	1+
D	54-4412	30 ml	\$9.05	\$9.81	\$10.90
	54-4412	125 ml	\$31.88	\$33.75	\$37.50
E	54-4413	30 ml	\$9.90	\$10.49	\$11.65
F	54-4414	125 ml	\$24.14	\$25.56	\$28.40
G	54-4414	1000 ml	\$193.34	\$201.74	\$210.15
	54-4414	3000 ml	—	—	\$514.20





Above 30% Silica

**R&R® ULTRA-VEST® INVESTMENT**

Ultra-Vest Investment offers casters smooth mixing, controlled setting, clean breakout, and excellent surface finish. Ultra-Vest eliminates the watermarking defects seen with many other investments. Ultra-Vest offers superior performance and unmatched consistency. For low temperature mold materials. Rapid prototype cooling.

Order # 22-4771

Description	Weight	1+
Ultra-Vest	50 lbs (23kg)	\$48.55
Ultra-Vest with Bandust	50 lbs (23kg)	\$65.90



A

**R&R® ADVANTAGE AND PLASTICAST**

A. **R&R Advantage** investment provides silver, brass, and bronze jewelry casters with an economical investment that reduces excess metal and watermarking defects for dependable casting results and maximum profits. For low temperature mold materials.

B. **R&R Plasticast** investment provides casters using plastic and wax/ plastic pattern materials with a mold material that meets the high expansion demands of the pattern material while maintaining mold surface and dimensional integrity.

Item	Order #	Description	Weight	1+
A	22-4773	Advantage	50 lbs (23kg)	\$40.55
B	22-4778	Plasticast	50 lbs (23kg)	\$60.60



B



Less than 50% Silica

**R&R® ULTRA-VEST® MAXX**

An investment that can be used for yellow gold, white gold, and palladium, MAXX is very stable for high-melt temperatures, flask temperatures, burnout temperatures, and casting temperatures. MAXX eliminates orange peel defects associated with metal and other mold reactions, or any other challenges in the burnout process associated with plastic and resin pattern materials. For low temperature mold materials. Rapid prototype cooling.

Order # 22-4776

Description	Weight	1+
Ultra-Vest MAXX	50 lbs (23kg)	\$59.70
Ultra-Vest MAXX with Bandust	50 lbs (23kg)	\$70.90



Less than 50% Silica

**R&R® SOLITAIRE INVESTMENT**

Solitaire Investment is designed to provide critical protection to stone-in-place castings. Solitaire Investment protects castable stones during the wax-burnout phase of flask preparation.

Order #	Description	Weight	1+
22-4772	Solitaire Investment	50 lbs (23kg)	\$53.60

Safety masks, gloves and aprons located on pages 517-519.

**PLASTICAST® PT INVESTMENT AND BINDER**

The PLASTICAST® PT investment and binder system was developed, and is ideally suited for, the investing and burnout of commonly used plastic or wax/plastic pattern materials. The high expansion of these pattern materials requires an equally high expanding, extra high strength investment. The PLASTICAST® PT investment and binder system provides jewelry casters with a mold material that meets those demands while maintaining mold surface and dimensional integrity for high temperature metal casting. The PLASTICAST PT investment and binder system can also be used with standard wax patterns for high temperature metal casting.

Order #	Description	1+
22-4779	Plasticast PT Investment & Binder	\$303.00



- Eliminates the acid-based binder hazard associated with common two-part platinum investments.
- Eliminates hazardous liquid storage
- Eliminates special investing flask preparation requirements.
- Eliminates cost associate with absorbent liners
- Eliminates time associated with complicated flask preparation

**INVESTMENT C/P AND LIQUID C/P (BINDER)**

A-D. Allows for same-day platinum casting. Sets up in minutes, burns out clean, and allows for two-hour burnout.

E-G. Phosphate-bonded speed burnout investment for all common metals for jewelry casting except titanium. Developed for precious metals with high melting points. Better surface quality by reduced particle size. Improved composition for the highly demanding requirements of rapid prototype materials.

Item	Order #	Description	1+
A	21-7047	5kg Invest C/P Speed Investment	\$58.85
B	21-7048	20kg Invest C/P Speed Investment	\$213.50
C	21-7049	Investment Liquid for C/P 1000ml	\$15.40
D	21-7057	Investment Liquid for C/P 5000ml	\$75.55
E	21-7058	Invest C/P Speed Investment with 1L Invest Liquid	\$66.90
F	21-7059	Invest RP Investment for Rapid Prototype Materials	\$56.60
G	21-7060	Invest RP Investment with 1L Invest Liquid	\$66.90



A

Sold in box of 32 individual 160g bags or in 5kg bulk package.



B

Sold in 20kg bulk package.



C



D



E



F



G

**INVESTMENT WARNING!** This material contains crystalline silica and shows evidence of causing cancer in humans. (ARC Group 1) Prolonged exposure may cause lung injury (silicosis). Users must comply with all applicable health and safety regulations relating to the safe handling of crystalline silica. See MSDS for information. California Prop 65 Warning: This product contains crystalline silica, a chemical known in the state of California to cause cancer.







**FERRO-VEST INVESTMENT**

Ferro-Vest V.H.T. is a two-part high temperature investment engineered for the casting of platinum, stainless steel, and alloys. Package contains 22.5 Kg box with plastic bottle for binder.

Order #	Description	Weight	1+
22-4745	Ferro-Vest	800 oz	\$151.00



**PRESTIGE OPTIMA? INVESTMENT**

Prestige OPTIMA is a significant breakthrough by Certus to develop a new generation, gypsum-bonded investment that consistently provides superior, smoother surface for casting today's resin patterns and a variety of other materials. OPTIMA is the ultimate investment for casting palladium white gold and alloys that require higher temperatures for casting. The extra high expansion properties of OPTIMA allow for the investment to expand ahead of resin patterns and other high expanding pattern materials, thus avoiding flashing, or cracking of the mold. Optima far surpasses the industry standard in all categories for investment.

Order #	Description	Weight	1+
22-4748	Prestige Optima™ Investment	800 oz	\$60.55



**PRESTIGE ORO? INVESTMENT**

Prestige ORO is true, premium gypsum-bonded investment developed and perfected for the casting of alloys up to 22K. To achieve the very best casting surface possible, ORO incorporates specially graded refractory minerals and specialized control chemicals that are proven to outperform all premium investments currently on the market. Independent tests performed by some of the world's best known casting companies, Prestige ORO have proven to be a truly superior investment for gold that far surpasses the industry standard in all categories for investment.

Order #	Description	Weight	1+
22-4747	Prestige Oro™ Investment	800 oz	\$58.55



**PRESTIGE UNICAST? INVESTMENT**

Prestige UNICAST is a premium quality gypsum-bonded investment in the Prestige line of investments designed for users that prefer one investment for multiple casting applications. UNICAST is a perfect choice for casting gold up to 18K and superior for producing the most complex designs in sterling and fine silver. Certus utilizes have a rigorous quality control system at their plant, which checks each and every batch of investment they manufacture. Their quality control system which is entirely customer focused, in that it ensures that the quality levels they achieve consistently remain stable for long term supplies. Certus is also continuously developing new investment products designed to supply the world markets' requirement.

Order #	Description	Weight	1+
22-4746	Prestige Unicast™ Investment	800 oz	\$55.50

Product	2 Part	High Temp	Casts Platinum	Casts Stainless	Casts up to 22K	Casts up to 18K	Casts Palladium	Casts Sterling Silver	Casts Resins
Ferro Vest	•	•	•	•					
Optima					•		•	•	•
ORO					•				
Unicast						•		•	



**KERR® SATIN CAST 20 INVESTMENT**

Satin Cast 20 satisfies the most critical caster demanding exacting tolerances. Kerr's extra-fine grain, zero mineralized cristobalite powder achieves defect-free castings and satin smooth finishes. Consistently superior results for metals melting under 2000 degrees Fahrenheit/1093 degrees Celsius.

Order # 22-47400

Item	Description	Weight	1+
A	Satin Cast 20	4.4 lbs (2kg)	\$18.20
B	Satin Cast 20	50 lbs (23kg)	\$49.45
C	Satin Cast 20	99 lbs (45kg)	\$100.00

**KERR® SATIN CAST DIAMANTE®**

With more than 20 years of experience as a stone-in-place investment, Satin Cast 20 is known as the most popular investment for this process. An investment formulated specifically for stone-in-place casting for higher temperature burnout.

Item	Order #	Description	Weight	1+
D	22-4750	Satin Cast	99 lbs (45kg)	\$94.10

**KERR® PLATINITE®**

Platinite is a high-strength and high-temperature investment for casting platinum, stainless steel, and alloys that melt above 2000 degrees Fahrenheit. Platinite forms a strong mold with good dimensional accuracy and caters to the exacting needs for excellence. An exceptionally smooth surface is achieved without cracks and fissures, which drastically reduces finishing time.

Item	Order #	Description	Weight	1+
E	22-4739	Platinite	99 lbs (45kg)	\$114.00

Stuller offers a wide range of investments to fit your casting needs

	Gold	Silver	Platinum	Palladium	Stainless Steel	Titanium	Stone in Place	Mix with Water	Mix with Binder	Ok for CAD/CAM Resins	Di-Vester Needed	UOM	Order #
Kerr Satin Cast 20	•	•						•		•		33 lbs	22-4738
Kerr Satin Cast Diamante	•	•					•	•				99 lbs	22-4750
Kerr Opticast			•	•	•				•	•	•	77 lbs	22-4755
R&R Ultra-Vest	•	•						•		•		50 lbs	22-4771
R&R Solitaire	•	•					•	•		•		50 lbs	22-4772
R&R Ultra-Vest MAXX	•	•		•				•		•		50 lbs	22-4776
Grobet Investment	•	•						•				25 lbs	22-4761
Invest C/P			•	•	•	•			•	•	•	11 lbs	22-7047
Platinite			•		•			•				11 lbs	22-4739

All items are priced at jeweler's cost, are sold each, unless otherwise noted, and are subject to change without notice. Visit [Stuller.com](http://Stuller.com) for our complete product selections, current pricing, and quantity price breaks. | 199



**INVESTMENT SCALES**

Item	Order #	Description	Capacity	12+	6+	1+
A	21-7700	Investment Scale	10 lb	\$19.76	\$20.93	\$23.25
B	21-7701	Investment Scoop		\$2.35	\$2.45	\$2.55
C	21-7720	Investment Scale	6.5 lb	\$14.32	\$15.17	\$16.85

**INVESTMENT SPATULA**

This wooden handle and stainless steel blade spatula is handy for many types of mixing jobs.

Item	Order #	Description	Set of	12+	6+	1+
D	21-1778	Investment Spatula	20	\$8.76	\$9.27	\$10.30

**RUBBER MIXING BOWLS**

Flexible for easy pouring.

Order # 21-76020

Item	Diameter	Height	Capacity	12+	6+	1+
E	5"	5"	1 pint	\$4.60	\$4.80	\$5.00
F	6"	6"	1½ quarts	\$8.28	\$8.64	\$9.00
G	8½"	6½"	1 gallon	\$17.20	\$17.95	\$18.70

**PRO-CRAFT® INVESTMENT VIBRATOR**

Three-speed, variable vibrator with great weight and a low center of gravity features quiet operation with great surface area on platform. Comes with an extra-long cord and three-prong grounded plug. 120V, 40W, 60Hz.

Item	Order #	Description	12+	6+	1+
H	21-7710	Investment Vibrator	\$70.17	\$74.30	\$82.55

**INTERVAL TIMER**

Interval timer for investment mixing. One to 60-minute timer. Weight ¾ lbs.

Item	Order #	Description	W×L×Depth	12+	6+	1+
J	21-9010	Interval Timer	2¼"×4½"×½"	\$17.60	\$18.63	\$20.70

**PLASTIC MEASURING CYLINDERS AND SYRINGE**

Item	Order #	Height	Capacity	12+	6+	1+
K	21-7400	16"	250ml	\$10.63	\$11.09	\$11.55
L	21-7401	6"	1000ml	\$11.18	\$11.66	\$12.15
M	58-2559		35ml	\$2.38	\$2.72	\$3.40

**INVESTMENT MIXING INSTRUCTIONS**

**Recommended Water/Powder Ratios**

**REGULAR Castings**

Ladies' rings, pendants, filigree and intricate wax patterns

**40 ml water to 100 grams powder**

Water		Yields Approximate	
avg oz	ml	cubic inch	CC
6.1	172	21	349

**HEAVY Castings**

Heavy ladies' rings, mens' rings and school rings

**36 ml water to 100 grams powder**

Water		Yields Approximate	
avg. oz	ml	cubic inch	CC
6.4	182	22	359

To get the number of pounds of investment needed to fill any particular flask, divide the cubic inch content of the flask by 20.  
To get flask content in cubic inches. Round Flask = 0.7854 x dia.2 x height. Square Flask = width x length x height.

**TEMPERATURE CONVERSION TABLE**

Conversion Formulas °F = (9/5 x °C) + 32° °C = 5/9 (°F - 32°)

°F	°C	°F	°C	°F	°C	°F	°C	°F	°C
600	316	830	443	1120	604	1410	766	1640	893
610	321	840	449	1130	610	1420	771	1650	899
620	327	850	454	1140	616	1430	777	1660	904
630	332	860	460	1150	621	1440	782	1670	910
640	338	870	466	1160	627	1450	788	1680	916
650	343	880	471	1170	632	1460	793	1690	921
660	349	890	477	1180	638	1470	799	1700	927
670	354	900	482	1190	643	1480	804	1710	932
680	360	910	488	1200	649	1490	810	1720	938
690	366	920	493	1210	654	1500	816	1730	943
700	371	930	499	1220	660	1510	821	1800	982
710	377	1000	538	1230	666	1520	827	1810	988
720	382	1010	543	1240	671	1530	832	1820	993
730	388	1020	549	1250	677	1540	838	1830	999
740	393	1030	554	1260	682	1550	843	1840	1004
750	399	1040	560	1270	688	1560	849	1850	1010
760	404	1050	566	1280	693	1570	854	1860	1016
770	410	1060	571	1290	699	1580	860	1870	1021
780	416	1070	577	1300	704	1590	866	1880	1027
790	421	1080	582	1310	710	1600	871	1890	1032
800	427	1090	588	1320	716	1610	877	1900	1038
810	432	1100	593	1330	721	1620	882	1910	1043
820	438	1110	599	1400	760	1630	888	1920	10





A



The wide, clear-view lid is slanted and hinged to open fully for easy access

Two built-in ports with rubber gloves give you complete control over your work

Media drain port

**PEN TYPE SAND BLASTER**

Manufactured by Ikohe to the design specifications of renowned tool maker Kate Wolf, this roomy, see-through sand blaster puts easy-to-use, high-quality finishing on your benchtop. The shape is ergonomic, contoured for increased visibility, effective bead-blasting, and easy clean-up and maintenance. The design includes a powerful, pressurized jet blaster and an independent exhaust air filtration system that prevents dust and media from becoming airborne, helping to keep your shop environment safe.

- Handheld pen-style etcher recirculates glass beads or aluminum oxide media. Use the handpiece freehand (simply slide the body out of its bracket) or leave it secured to the cabinet wall for hands-free use (adjust the pivoting nozzle to get the best angle for your workpiece). One plastic blasting nozzle and three replacement ceramic insert tips are included.
- Clear, heavy-duty cabinet measures just 20"W x 17"D x 17"H. Two built-in ports with rubber gloves give you complete control over your work; one pair of replacement gloves is included.
- A built-in grate allows media to collect in the bowl-shaped base of the cabinet but allows you to set pieces down without them falling into the media reservoir.
- The wide, clearview lid is slanted and hinged to open fully for easy access. It has an airtight gasket and locks closed when in use. The interior surface of the lid has a protective, clear Mylar® shield. Simply remove and replace the molded Mylar sheet when its surface becomes clouded enough to impair your view. One replacement shield is included.
- Requires 90-100 PSI compressed air; 1.5CFM.
- Do not use mixed media sizes and do not mix different types of media. Do not use silicon carbide media, because it is a contaminating media.
- Use glass beads or aluminum oxide media, 120/180-grit.
- Clear molded chamber for visibility from all sides
- Easy two-handed operation using heavy-duty latex gloves
- Ceramic nozzle can be mounted on the bracket or used by hand
- Media drain

Item	Order #	WxLxH	PSI	1+
A	23-0082	17"x20"x17"	42-70	\$560.00

**REPLACEMENT PARTS**

Order # 23-0083

Item	Description	12+	6+	1+
B	Latex Gloves for Wolf Sand Blaster	\$10.07	\$10.51	\$10.95
C	Replacement Blasting Nozzle for Wolf Sand Blaster	\$17.43	\$18.19	\$18.95
D	Exhaust Filter for Wolf Sand Blaster	\$10.99	\$11.47	\$11.95



B

C

D

**E-Z VIEW SAND BLASTER**

The E-Z Blaster unit is designed to remove hardened investment from castings and to also produce a rich satin finish on jewelry. The cabinet is made of a one-piece polymer body, which will never rust or leak. The unit automatically recirculates the media and features an adjustable pressure regulator and a self-cleaning ceramic nozzle. It also includes a bright light for easy viewing and a double filter bag to ensure a clean interior. Made in the USA.

- Requires 80-90 PSI.
- Comes with five pounds of quartz abrasive that provide a strong, satin finish.

Item	Order #	Description	Volts	W x L x H	1+
A	23-0080	E-Z Sand Blaster	110	10"x11"x15"	\$526.50



18 lbs



**GLASS BEAD BLASTER**

Produces a stream of micro-sized glass beads for removing stubborn investment particles, oxidation, and heat scale from metal. Leaves articles with smooth finish. Made in the USA.

- Large viewing window with hinged door for easy clean-out.
- Illuminated interior (40-watt bulb maximum).
- Neoprene glove sealed to opening for holding article.
- Easily controlled instant action gun.
- Gun is attached to 3/2" airline hose with fittings.
- Connects to compressor (sold separately), capable of producing 30-60 psi pressure with at least a five-gallon tank.
- Portable - Weighs only 10 pounds when filled with five pounds of glass beads.
- Includes five pounds, waterproof micro-sized glass beads.

Item	Order #	Description	Size	1+
B	23-0050	Bead Blaster	9"x9"x9"	\$297.50
C	23-0051	Filter		\$39.35
D	23-0052	Neoprene Gloves		\$15.95
E	23-0053	Air Gun	6.19 oz	\$74.90
F	23-0054	On Face Tube	6.17 oz	\$27.70
G	23-0049	Replacement Media	5 lbs	\$19.15



C

D

E

F

G



**GLASS BEADS**

- Fast cutting action
- Safe substitute for sand (does not cause silicosis)
- Improves performance of other media by blending
- Improved water jet cutting and cleaning performance
- Cleans thoroughly and very efficiently
- Lower disposal and maintenance costs
- Available in a full range of sizes

Item	Order #	Grit	12+	6+	1+
H	23-0073	20-40	\$10.49	\$10.94	\$11.40
J	23-0074	50-80	\$10.49	\$10.94	\$11.40
K	23-0075	70-120	\$10.49	\$10.94	\$11.40
L	23-0076	120-230	\$10.49	\$10.94	\$11.40
M	23-0077	140-325	\$10.49	\$10.94	\$11.40
N	23-0078	170-400	\$10.49	\$10.94	\$11.40



H

J

K

L

M

N



# CLEANING



B. Model 6000CJ

**B. Model 6000CJ**

- Six hours of continuous steam
- Water Capacity: 1¼ gallons (4.5 liters)
- Up to 65 psi, 4.5 bar operating pressure
- 1200 watt heating element
- 10 amps power consumption
- Unit weight: 16.7 lbs.
- Shipping weight: 23 lbs.

Find added video content on [Stuller.com](http://Stuller.com).



Item	Order #	Description	WxDxH	1+
A	15-1110	Reliable Model 5000CJ	14"×8¾"×11"	\$599.00
B	15-1105	Reliable Model 6000CJ	13"×8¾"×15"	\$899.00
C	15-1112	Reliable Model 9000CJ	11½"×11"×39"	\$2,299.00
D	15-1116	Foot Switch		\$121.20
E	15-1109	Solenoid Valve		\$126.25

These steamers are ideally suited for use in jewelry stores and workrooms for cleaning away leftover wax plaster waste and other debris and for polishing the final product. Steam deodorizes and sanitizes with heat and moisture. Since the only ingredient required for these is regular tap water, cleaning has never been safer, healthier, or more environmentally friendly. They provide up to six hours of steam from a stainless steel tank.

- Adjustable nozzle and foot pedal
- Four safety systems
- Water level stick
- Pressure gauge
- Incology heating element
- Blowdown valve
- Quick-release fittings

**A. Model Reliable 5000CJ Steam Cleaner**

- Four hours of continuous steam
- Water Capacity: .66 gallons (2.5 liters)
- Up to 50 psi, 3.4 bar operating pressure
- 1,000 watt copper heating element
- 10 amps power consumption
- 1,800 watt electrical (iron and boiler)
- Rated for up to eight hours of use per day
- Unit weight: 13 lbs.
- Shipping weight: 16 lbs.



A. Model 5000CJ



C. Model 9000CJ

**C. Model Reliable Model 9000CJ**

- Unlimited continuous steam when connected to a water supply
- Water Capacity: 1.3 gallons (5 liters)
- Up to 80 psi, 5.5 bar operating pressure
- Two 1200 watt heating elements (1 spare)
- 10 amps power consumption
- 20 amp plug required
- Automatic shut-off of pump
- Boiler thermostat reset switch
- Direct connection to water line
- Optional portable water supply
- Unit weight: 36 lbs.
- Shipping weight: 46 lbs.

**SHARPERTEK® STEAMER**

Sleek table-top unit makes a great impression and delivers reliable, superior performance with its compact, durable, state-of-the-art design. Atmospheric technology directly converts distilled water into high-powered, super-heated, dry steam cleaning energy on demand at 70-90 psi. Effectively cleans dirt, residue, and build-up with excellent penetration and exceptional control for even the most delicate of jewelry. It's safe, efficient, and green. This steamer requires no boiler tank, harsh chemicals, or detergents. The tank stays cool to the touch. Proudly designed, engineered, and manufactured in the U.S.A. to meet the highest standards anywhere in the world.

Item	Order #	Description	Model	WxLxH	1+
A	15-1000	Steam Cleaner	S1500-R	9"×14"×10"	\$395.00



**GEMORO® ULTRASPA COMBO ULTRASONIC AND 50 PSI STEAMER**

The UltraSpa has both powerful ultrasonic cleaning and high-pressure steam cleaning in a single appliance. The two-stage cleaning process starts with intense ultrasonic sound waves scrubbing dirt and grime. Then the steamer blasts away hidden dirt and the remaining residue from all hard-to-reach areas. Tank capacity is approximately one-pint. Generates a powerful 42,000 scrubbing waves per second. Comes equipped with a basket and evaporation resistant transparent cover with bright blue built-in LED tank. Illumination control panel provides a six-minute timed cleaning cycle that automatically shuts off when completed. Powerful steam cleaner safely generates a robust 50 PSI of pressurized steam using regular tap water. Built-in water fill funnel. Includes steam residue mat, measuring fill cup, tweezers, and two sizes of handheld mesh baskets that both store in a clever rear compartment.

Item	Order #	Description	1+
B	23-5906	GemOro® Ultra Spa Combo Ultrasonic and 50PSI Steamer	\$149.97



**GEMORO® BRILLIANT SPA BLACK DIAMOND STEAMER**

Black Diamond Personal Jewelry Steam Cleaner New larger capacity steamer with even greater steam pressure cleans more and cleans faster. The best just got better. The ultimate personal jewelry steam cleaner with its increased steam pressure will thoroughly amaze you by effortlessly blasting away filth from the dirtiest of jewelry in just seconds, even in the tiniest of nooks and crannies of intricate pieces. With its larger tank and steam capacity, you may clean your entire collection of jewels and more with ease.

**Order # 15-2009**

Item	Description	Color	1+
C	Brilliant Spa Black Diamond Steamer	Black	\$99.95
D	Brilliant Spa Black Diamond Slate Steamer	Gray	\$99.95



- Professionally cleans diamonds, gold, silver, and platinum jewelry
- Tank capacity: approximately one pint
- Powerful steam cleaner safely generates a robust 50 PSI of pressurized steam using regular tap water safely blasts away dirt, grime, body oil, makeup, and more
- Advanced LED indicator lights show when unit is heating and when it is ready to steam
- Bright blue LED light illuminates jewelry while being steam cleaned
- Features an unrestricted cleaning zone, removable cleaning/drying basket and convenient on/off power switch
- Easy-lift handles for moving
- Cabinet made of durable, long-life ABS, with contemporary stainless steel accent panels

- Includes jewelry holding tweezers, basket, steam residue mat, and water funnel with measuring fill cup
- Complements sister product: GemOro Sparkle Spa Pro® Personal Ultrasonic Jewelry Cleaner
- Designed in the USA with European influence
- Built for safety; ETL Listed
- Two-Year limited replacement warranty
- Ship weight 6 lb.





A new generation of steam cleaning performance, quality, and durability.

- External sight glass with cover
- Low water cutoff
- Water intake valve with backup flow prevention
- Adjustable thermostat
- Insulated nozzle assembly
- 2.3 gallon capacity
- 70-80 PSI steam pressure
- 1,500 watts
- 110 volt
- 13 amp
- One-year warranty



Item	Order #	Description	Size	1+
A	15-0510	Steamer with Solenoid	14½"×10½"×14"	\$1,395.00
<b>REPLACEMENT PARTS</b>				
B	15-0512	Safety Valve		\$258.00
C	15-0514	Nozzle		\$16.85
D	15-0509	Check Valve		\$30.25
E	15-0515	Ball Valve	¼"	\$27.85
F	15-0513	Plastic Housing for Glass Tube		\$36.40
G	15-0520	Sight Glass	6"	\$21.35
H	15-0516	Foot Switch and Cord		\$79.80
J	15-0511	Solenoid Valve		\$107.10
K	15-0519	Thermostat		\$35.35
L	15-0517	Ball Valve	¼"	\$33.80
M	15-0530	Heating Element		\$85.85
N	15-0525	Low Water Cut-Off		\$52.05
P	15-0518	Pressure Gauge		\$38.40
Q	15-0531	Rubber Gasket		\$4.20
R	15-0524	On/Off Switch		\$6.45
S	15-0012	Ferrule Fitting		\$3.05



Hoffman offers technologically-superior micronic cleaning. Grease, grime, and micro-deposits disappear in seconds no messy rag, lint, or baths. It's faster and easier to remove oxidation and deposits from the tiniest crevices for a bright, sparkling finish. Inexpensive to operate, Hoffman Steemkleen machines offer outstanding value. Choose from the two- or six-gallon capacities that start up faster, recover temperature and pressure faster, and finish your job faster with less labor. Automatic safety valves make our micronic cleaners safer.



- A. Model JEL-3**
- A.S.M.E. and U.L. approved
  - Tank capacity two gallons
  - Saves time and boosts productivity
  - Develops 70-90 PSI steam
  - Safety shielded sight glass w/stainless steel cabinet
  - Plugs into any 110 or 220 VAC outlet
  - Easy reservoir refill manual
  - Adjustable thermostat controls
  - Auto low water cutoff
  - Total operator control
  - Rust-inhibited pressure tank (no rust or corrosion)
  - Fingertip or foot switch controls
  - 110 volts 13 amp
  - 23.5" h x 17.6" w x 20.5" d

Shipping Weight  
70 lbs

Net Weight  
64 lbs

Item	Order #	Description	1+
A	15-0503	JEL-3, 2 gallons	\$1,325.00
B	15-0505	JEL-10, 6 gallons	\$4,310.00
C	15-0501	Gem 3 Steamer	\$780.00
<b>REPLACEMENT PARTS</b>			
D	15-0521	Washers (Pack of 2)	\$5.65
E	15-0522	Sight Glass Cover	\$28.00
F	15-0517	Ball Valve	\$33.80
	15-0520	Sight Glass	\$21.35
	15-0502	Solenoid Valve for JEL-3	\$199.05
	15-0504	Heating Element	\$164.35
	15-0506	Replacement Gasket	\$6.05
	15-0525	Low Water Cut-Off	\$52.05
	15-0516	Foot Switch and Cord	\$79.80

- C. Model Gem 3**
- Screw in element for quick reheat and recovery
  - No high-pressure boiler to worry about leaks
  - Uses distilled water straight from a jug
  - Electric foot pedal control
  - 11"H×9"W×11"D

- B. Model JEL-10**
- A.S.M.E. and U.L. Approved
  - Tank capacity: six gallons
  - 220 Volts/three phase/60Hz
  - Steam outlet: solenoid with foot switch
  - Easy reservoir refill (pump & motor)
  - Fast temperature/pressure recovery
  - Auto low water cutoff
  - 35"H×22"W×22"D





One of the most respected names in ultrasonic cleaning technology traces its origins to 1948 with the development of watch cleaning machinery that became recognized as the world's best. Elma, in 1965, introduced ultrasonic cleaning devices targeting the jewelry, dental, optical, and laboratory sectors.



**ELMASONIC® EASY**

The Elmasonic EASY family includes a range of nine different device sizes with tank volumes ranging from 0.8 to 28 Liters. Microprocessor-controlled ultrasonic with sweep technology offers a state-of-the-art solution.

**Product features—**

- Efficient 37 kHz ultrasonic high-performance transducers
- Cleaning tank made of cavitation-resistant stainless steel
- User-friendly and clearly arranged operating panel, sealed against liquid intrusion to protect the electronics
- LED display for ultrasonic function
- Rotary switch for easy pre-selection of the cleaning time
- Continuous operation or short-term operation between one and 30 minutes
- Permanent sweep function or optimized sound field distribution through frequency modulation
- Dry-run protected heating
- Temperature selectable by rotary switch; from 30°C to 80°C in increments of 5°C (for H Units)
- LED display for heating operation (for H units)
- Detachable power cord with IEC plug
- Selectable temperature threshold with alarm
- Automatic safety shutdown after eight hours of continuous operation
- Automatic safety shutdown at a bath temperature of 90°C
- Pulse Function



A. Model 20 H



Adjustable temperature control

Item	Order #	Description	WxDxH	1+
	15-20510	Elmasonic Easy 10 H	8 1/8" x 3 3/8" x 7 1/4"	\$353.10
A	15-20510	Elmasonic Easy 20 H	6 7/8" x 4 3/4" x 8 5/8"	\$409.15
	15-20510	Elmasonic Easy 30 H	10 3/8" x 4 7/8" x 8 5/8"	\$442.75
	15-20510	Elmasonic Easy 40 H	10 3/8" x 4 3/4" x 10 3/8"	\$644.55
B	15-20510	Elmasonic Easy 60 H	13 3/8" x 5 1/4" x 10 3/8"	\$756.65
	15-20510	Elmasonic Easy 100 H	13 3/8" x 8 3/4" x 10 3/4"	\$902.35
C	15-20510	Elmasonic Easy 120 H	13 1/2" x 8 1/2" x 12 3/4"	\$1,165.75
	15-20510	Elmasonic Easy 180 H	14 3/8" x 10 7/8" x 12 3/4"	\$1,277.85
	15-20510	Elmasonic Easy 300 H	21 3/8" x 10 7/8" x 12 3/4"	\$1,602.90

**ELMASTEAM 4.5**

This powerful German-made Elma steamer uses a combination of pressure, speed, and temperature as the secret to professional steam jet cleaning. Microscopically tiny steam particles reach hardly accessible crevices and the smallest recesses. Therefore, the steam thoroughly removes dirt particles, such as dust, grease, and polishing pastes. No chemical cleaning agents are necessary, so no lime or detergent residue is left on the clean surfaces. The new Elmasteam 4.5 basic is available with a fixed nozzle at 4.5 bars of pressure. The professional steam pressure of 4.5 bars cleans even sensitive parts and instruments safely and effectively. With the higher water content of the steam at 4.5 bars, waxes can be easily melted and removed from the parts. Due to the strong heating of Elmasteam devices steam is available for a longer time. Furthermore, Elmasteam 4.5 is the perfect steam jet cleaner to clean complicated instruments, such as burs, drills, or electro-surgical instruments which often do not become sufficiently clean in the standard washing and disinfecting unit. Pre-cleaning the instruments (even hollow instruments) with Elmasteam 4.5 prolongs the service life of the cleaned items. You'll discover quality in every detail of the Elmasteam 4.5 units: sophisticated 2-chamber design which separates the water-bearing from the electric system and aluminum alloy material to ensure a long service life of the tank.

**Order # 15-2050**

Item	Description	WxDxH	1+
A	Elmasteam 4.5 Basic	8 1/2" x 11 1/2" x 15"	\$1,180.00
B	Elma Steamer Mounting Accessories		\$27.95



B



B. Model 60 H



C. Model 120 H

Cleaning

Cleaning





**ELMA® P-SERIES ULTRASONIC**

The ideal cleaner for all applications. The units are easy to operate with clearly arranged displays showing frequency and settings vs. actual settings of selected temperature.

- Pulse operating mode to intensify the cleaning effect.
- High frequency for dissolving dirt or rouge in hard-to-reach areas.
- Low frequency
- Power reduction by increments of 10% to aid in sensitive surfaces
- Degas Mode, Degas mode removes such oxygen.

Order # 23-5950

MFG Model #	WxDxH	1+
Elma Model P30H	11 1/8" x 7 1/10" x 8 7/10"	\$859.00
Elma Model P60H	14 5/8" x 7 1/10" x 10 5/8"	\$1,189.00
Elma Model P70H	22 1/8" x 7 x 8 7/10"	\$1,289.00

**ELMA® XTRA TT SERIES**

Elmasonic Xtra TT tabletop ultrasonic devices are designed for use in protection environments, workshops, and servicing. Features like the permanently integrated sweep function, the switchable dynamic function or the individually settable limit temperature with LED warning indicator make the cleaning of parts in a day to day work much easier. All functions and cleaning parameters like time and heating preselection and ultrasonic frequency are arranged user-friendly on the control panel on the front of the device where users can set and monitor them at a glance. With their ultrasonic performance of 37 kHz, Elmasonic xtra TT devices are rated for continuous heavy-duty operation. The tanks are made of special stainless steel, which makes the robust with a long service life. If they are used in a single-shift operation, they are guaranteed for three years.

**Elma 30H**

**Mechanical Data-**

- Max Volume of Trough (L) – 3
- Internal Dimensions (WxDxH, mm) 240x130x100
- External Dimensions (WxDxH, mm) 360x230x250
- Max Basket Loading (kg) – 1
- Ball Valve (in) – 3/8"

**Elma 60H**

**Mechanical Data-**

- Max Volume of Trough (L) – 6.5
- Internal Dimensions (WxDxH, mm) 300x150x150
- External Dimensions (WxDxH, mm) 420x250x300
- Max Basket Loading (kg) – 3
- Ball Valve (in) – 3/8"

**Elma 120H**

**Mechanical Data-**

- Max Volume of Trough (L) – 14
- Internal Dimensions (WxDxH, mm) 300x240x200
- External Dimensions (WxDxH, mm) 440x340x300
- Max Basket Loading (kg) – 7
- Ball Valve (in) – 3/8"

Order # 15-2083

Item	MFG Model #	WxDxH	1+
A	Elma 30 H	360"x230"x250"	\$967.00
B	Elma 60 H	420"x250"x300"	\$1,290.30
C	Elma 120 H	440"x340"x350"	\$1,938.15

**REPLACEMENT BASKETS**

Order # 15-2084

MFG Model #	WxDxH	1+
Elma Model 30 H	196"x112"x48"	\$85.25
Elma Model 60 H	257"x132"x73"	\$117.60
Elma Model 120 H	263"x223"x114"	\$139.15



A. Elma 30H



B. Elma 60H



C. Elma 120H



**ELMA® S-SERIES ULTRASONICS**

Powerful, professional ultrasonic for all applications. The series increases the ultrasonic effect farther to obtain even better results. Made in Germany.

- The sweep function, developed in the Elma laboratories, guarantees a sound field distribution by way of continuous shifting.
- The degas function efficiently accelerates the degassing process in the cleaning liquid, particularly in freshly mixed baths.
- When used in tough long-term operations you will find that the new units with their functional design fully meet the demands of any cleaning task.

- Ultrasonic frequency of 37 kHz
- 3/8" Drain duct/diameter
- Sweep function

- Degas mode
- One year limited warranty
- Variable heat

**Model S100**

- Tank Capacity: 9 1/2 quarts (9.5 liters)
- Tank Dimensions: 11 1/8" x 9 1/2" x 5 5/16"
- Total Power Consumption: 150/550 watts

- Heating Power: 0/400 watts
- Voltage: 110V
- Weight: 5.9 lbs.

**Model S30**

- Tank Capacity: 2 1/2 quarts (2.75 liters)
- Tank Dimensions: 9 1/2" x 5 3/8" x 3 9/16"
- Total Power Consumption: 80/280 watts

- Heating Power: 0/200
- Voltage: 110V
- Unit Weight: 3.3 lbs.

**Model S40**

- Tank Capacity: 3 3/4 quarts (4.25 liters)
- Tank Dimensions: 9 1/2" x 5 3/8" x 5 5/16"
- Total Power Consumption: 140/340 watts

- Heating Power: 0/200 watts
- Voltage: 110V
- Weight: 4 lbs.

Order # 23-59280

Item	MFG Model #	WxDxH	1+
A	Elma Model S100	14 3/8" x 10 9/16" x 10 3/8"	\$1,199.00
B	Elma Model S30	11 1/8" x 7 1/10" x 8 3/8"	\$579.90
C	Elma Model S40	11 1/8" x 7 1/10" x 10 3/8"	\$795.90



A. Model S100



B. Model S30



C. Model S40

**STULLERSONIC CLEANER**

This machine is ideal for the small trade shop or for the retail counter. Handy and robust the sandwich transducer system ensures high reliability. Complete stainless steel construction prevents rusting or oxidation. Compact in size and price but not in quality. Comes with 15-minute timer switch.

Made in Germany.

- Maximum temperature 140°F
- Weight 6 lbs.
- 0.8 liters capacity
- Frequency 35kHz
- Power consumption 30 watts/100 watts (heater)
- Tank dimensions: 7"x3"x2" (external)

Item	Order #	Description	1+
D	23-5874	Stullersonic with Heater	\$349.90
E	23-6208	Stainless Steel Basket	\$40.25







A. Model: 28-180



B. Model: 28-330



C. Model: 28-600

**BEST BUILT ULTRASONIC CLEANER**

Ultrasonic Cleaners utilize industrial transducers to create powerful 40KHz ultrasonic wavelengths: short enough to clean the finest details of your jewelry and powerful enough to removed caked-on dirt as well as rouge and other compounds. Industrial strength transducers are more powerful and more durable than the standard wafer transducers found in most jewelry ultrasonics. All four ultrasonics have heaters, a 30-minute timer, and a stainless steel lid. The three largest units feature variable temperature control.

**A. Model: 28-180**

- Weight: 7 lbs.
- Unit Size: 7"x6.4"x8.3"
- Capacity: 1.8L/0.48 gal.
- Output: 60w/110v
- Frequency: 40KHz
- Tank Size: 5.9"x5.3"x3.9"

**B. Model: 28-330**

- Weight: 10 lbs.
- Unit Size: 11.7"x6.4"x9.8"
- Capacity: 3.3L/0.87 gal.
- Output: 100w/110v
- Frequency: 40KHz
- Tank Size: 9.4"x5.5"x3.9"

**Features:**

- Temperature Controller with separate on/off button
- Timer knob with separate on/off button

**C. Model: 28-600**

- Weight: 12 lbs.
- Unit Size: 14.1"x6.9"x11.9"
- Capacity: 6L/1.58 gal.
- Output: 150w/110v
- Frequency: 40KHz
- Tank Size: 11.4"x5.9"x5.9"

**Features:**

- Temperature Controller with separate on/off button
- Timer knob with separate on/off button

**Order # 23-5710**

Item	Container Volume	1+
A	2 Quarts	\$299.00
B	3 Quarts	\$399.00
C	6 quarts	\$699.00



Adjustable temperature control



Adjustable timer control



**Stuller Tried and Tested**

HOW STULLER FINDS TOOLS THAT STAND THE TEST OF TIME



There's no better way to waste time than by investing in a shoddy tool. That's why Stuller goes above and beyond, trying and testing every single new tool product in-house before deciding on whether or not to offer it.

Like you, Stuller works with various vendors who are always eager to place their new products. But we subject every

single tool to intense scrutiny. If it can't perform under the pressure of the production lines here at Stuller, we don't carry it in our line.

When you buy a tool from Stuller, you can always rest assured that it has been tried, tested, and approved by a Stuller professional.





L&R® Quantrex® systems are manufactured with vinyl-clad steel housings, stainless steel tanks, and premium system components. Their contemporary design and quiet operation are a complement to the importance of beauty and elegance within the jewelry industry. The Quantrex line is backed by the most comprehensive warranty in the industry: all defects in materials or workmanship are covered for 2½ years.

**PERSONAL-SIZED ULTRASONIC CLEANER**

- Tank dimensions: 4¾" x 3⅝" x 2⅝"
- Overall dimensions: 5⅝" x 4⅞" x 4 ¾"
- Tank capacity: 18 oz.
- Peak output: 70 watts
- 117v AC
- Heater and Timer, Basket not included

Order #	Description	1+
23-5850	PC3	\$170.00
23-5851	Stainless Steel Basket	\$42.00



**QUANTREX® Q90**

- Tank dimensions: 5⅞" x 5⅝" x 4"
- Timer and heater included
- Capacity: two quarts (1.9 liters)
- 117V AC
- Overall dimensions: 6⅞" x 6⅝" x 8⅞"
- Fits two-quart baskets
- Maximum temperature 150°
- Peak output: 160W, 43 kHz
- Not for use with soft stones

Order #	Description	1+
23-5854	Quantrex 90	\$315.00



**QUANTREX® Q140**

- Tank dimensions: 9⅞" x 5⅝" x 4"
- Peak output: 270W
- Capacity: 3⅝ quarts
- Timer and heater
- Overall dimensions: 10⅞" x 6⅝" x 8"
- 117V AC
- Fits two-quart and three-quart baskets

Order #	Description	1+
23-5858	Quantrex Q140	\$455.00



**QUANTREX® Q210**

- Tank dimensions: 9⅞" x 5⅝" x 4"
- Peak output: 400W, 43 kHz
- Capacity: six quarts
- Timer and heater
- Fits two-quart and three-quart baskets

Order #	Description	1+
23-5859	Quantrex Q210	\$897.00



**GEMORO® SPARKLESPA® PEARL**

Quickly and easily scrubs jewelry clean with powerful ultrasonic sound waves. Our SparkleSpa® personal ultrasonic provides the same amazing cleaning performance and sparkling results you'd get from a visit to your jeweler. High-intensity sound waves safely and effectively scrub your jewelry clean like it was just polished by your jeweler, leaving it looking showroom new. Proven to remove the toughest dirt, grime, body oil, cosmetics, and body care products from your jewelry. Far superior to gimmicky sonic cleaners, shaker jars, or any standalone cleaning solution, the SparkleSpa® is the professional way to clean jewelry.

**FEATURES:**

- It's simple. Plug in, fill with water, place your jewelry in the basket, and turn it on
- 600ml capacity ultrasonic tank
- Quickly and easily clean your jewelry with gentle yet powerful ultrasonic sound waves
- No scrubbing or polishing required, cleans in only minutes
- Three programmable cleaning cycles: three, five, and 10 minutes

Order #	Description	Capacity	12+	6+	1+
23-5901	SparkleSpa® Pearl	1½ pint	\$37.09	\$39.28	\$43.64



Guaranteed to remove dirt, grime, body oil, cosmetics and body care products from your jewelry. Designer white pearl finish bright blue LED illuminates the stainless steel tank includes a removable basket and bracelet/watch holder. One-Year limited replacement warranty.

**GEMORO® DIGITAL ULTRASONIC**

Professional cleaning power is available in this simple, small, and well-priced unit. This ultrasonic is designed for home and professional use with enough power and durability to be used in a jewelry store. Simply add clean, distilled water, jewelry cleaner concentrate (sold separately), and your jewelry in the tank. Start the cleaning cycle and watch as your jewelry is cleaned. You'll be pleased as dirt, body oil, soap scum, dead skin, and other filmy substances are loosened and removed in a matter of minutes.

Tank dimensions: 6¾" x 5 ⅓" x 2¾".

Order #	Description	W×L×H	1+
23-5904	Ultrasonic with Basket	7"×9"×6"	\$68.85



**SPEED BRITE IONIC CLEANING SYSTEMS**

The Speed Brite Ionic Cleaning System is an odorless, silent process that instantly removes tarnish from gold and silver and will not damage soft stones such as emeralds, opals, turquoise, and pearls. Operation is quick and easy. Ions are attached to the contaminants rather than the metal and stones. The surface tension is reduced, which permits the contaminants to be lifted away by soft bubbles. Made in the USA.

Item	Order #	Description	1+
A	23-6500	Model 100SB	\$63.55
B	23-6501	Model 200 Turbo	\$125.00
C	23-6502	Model 309 Turbo	\$185.00
D	23-6610	32 oz (liquid)	\$17.05
E	23-6611	1 gallon (liquid)	\$31.85
F	23-6612	32 oz (powder)	\$18.15
G	23-6612	8 oz (powder)	\$13.65

**GEM SPARKLE CLEANING SOLUTIONS**



- A. Model 100SB**
- 4" W x 5" H
  - Stainless steel basket
  - 6 oz. tank capacity
  - 4 oz. Gem Sparkle concentrate
  - Battery operated
  - Ring hanger

- B. Model 200 TURBO**
- 5¾" W x 5¾" H
  - Stainless steel basket
  - 12 oz. tank capacity
  - 32 oz. Gem Sparkle concentrate
  - Available in 110V or 220V
  - Ring hanger



- C. Model 309 TURBO**
- 10¾" W x 6¾" H
  - Stainless steel basket
  - 12 oz. tank capacity
  - 32 oz. Gem Sparkle concentrate
  - Available in 110V or 220V
  - Ring hanger



**MEDELCO® SONIC CLEANER**

Sonic cleaning has many of the advantages of an ultrasonic without the high cost. This is an excellent promotional item and comes in an attractive resale box. Housing and tank are sturdy plastic. Supplied with instructions, lid, and perforated dip tray. Made in China.

- Tank dimensions: 3" x 2" high
- Capacity: 8 ounces

Order #	Description	12+	6+	1+
15-0580	Medelco® Sonic Cleaner	\$11.69	\$12.38	\$13.75



**MAGIC CLEAN STEAM®**

Use this super-concentrated additive to prevent scale, rust buildup, and mineral deposits inside steamer, while helping prolong the life of your steamer. Note: Use one full cup each time steamer is filled.

Order #	Description	12+	6+	1+
54-4430	16 oz Bottle	\$5.53	\$5.85	\$6.50



**GRIFFITH STEAM CLEAN ADDITIVE**

This is a chemical that is used after the Blow-Out of the machine. This will keep the inner parts of the steamer working at top performance. Not for use with boilerless steam cleaners.

Order #	Description	12+	6+	1+
54-4425	Steam Clean Additive	\$5.06	\$5.28	\$5.50



**ULTRA-CR BY POLYCHEM®**

Ultra-CR is a mildly alkaline, concentrated cleaning solution specially formulated for the jewelry industry. Ultra-CR easily removes all buffing and polishing compounds from gold, silver, platinum, brass, copper, and rhodium without the use of ammonia or other harsh chemicals. This patented blend of sequestrants, surfactants, and emulsifying agents eliminates streaking and dulling. Ultra-CR has gone through comprehensive development and testing at Stuller's manufacturing facility. It's proven to be longer lasting and superior to other cleaners on the market. Ships UPS Ground only. (Dilute 10 to 1.)

Order # 54-44500

Item	Description	Container Volume	12+	6+	1+
A	Container	1 gallon	\$21.20	\$23.85	\$26.50
B	Drum	15 gallon	\$261.19	\$272.54	\$283.90
C	Container	2½ gallon	\$50.63	\$54.90	\$61.00
D	Drum	55 gallon	—	—	\$731.45



A



B



C



D



E

**L&R® ULTRASONIC SOLUTIONS**

- A. Waterless cleaning solution especially formulated for use with all L&R rinses and cleaning machines. Rinse with No. 54-4395. Will not spot or streak. Contains ammonia.
- B. Waterless, non-ammoniated solution, formulated for use on ultrasonic cleaning units. Won't spot or streak. Greater solvency on greases, gummed oils, and containments. Rinse with No. 54-4395.
- C. Ready-to-use, waterless, and non-ammoniated clock cleaning solution.
- D. Biodegradable super concentrate used at a 3% to 20% concentration with water. Removes most buffing compounds without discoloration of metal. Can be heated in an ultrasonic machine up to 180°F to enhance cleaning. Contains no film-forming corrosion inhibitors, so parts can be plated without any additional cleaning. Do not use on aluminum.
- E. Ellanar cleaner is an effective solution without the added ammonia. Safe to use on gold, diamonds, and gems.



Item	Order #	Description	Container Volume	1+
A	54-4392	#111 Ammoniated Watch Cleaner	1 gallon	\$47.20
B	54-4393	#566 Non-Ammoniated Watch Cleaner	1 gallon	\$43.00
C	54-4397	#677 Clock Cleaner	1 gallon	\$51.65
D	54-4402	Buffing Compound Cleaner	1 gallon	\$41.45
E	54-4403	Ellanar Jewelry Cleaner	1 gallon	\$36.60

**ULTRASONIC/ STANDARD WATCH RINSE**

- F. Fast drying, long lasting, and won't break down. Specially formulated for use with Watch Cleaner #111. Can be used with any watch cleaning solution. Compatible with all cleaners.
- G. Clear petroleum distillate, specially blended by L&R. Contains no benzoil or chlorinated solvents. Leaves no oily film. Dries fast. Use in ultrasonic with Cleaner #111; in standard machines, with No-Foam Watch Cleaner. Compatible with all cleaners.



Item	Order #	Description	Container Volume	1+
F	54-4395	Standard Rinse	1 gallon	\$47.20
G	54-4394	#3 Rinse	1 gallon	\$48.20



F



G





A



B



C

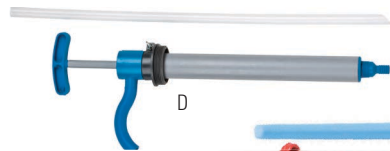

D



E



F



G

**SPARKLE PAK PRO SOLUTION**

GemOro SparklePak Plus is a professional strength concentrated ultrasonic cleaning solution. Box of 10 single-use packets contain the precise amount of jewelry cleaning solution that when added to 1-1.5 pints of water produces the best ultrasonic cleaning solution to make your jewelry like new again. Non-ammoniated, non-toxic, and non-flammable

Item	Order #	Container Volume	12+	6+	1+
A	54-0900	8 oz	\$8.20	\$9.23	\$10.25

**CLEANING CONCENTRATE**

Tivaclean is an electrocleaning concentrate for both metals and plastics. It is an orange powder that changes to a fluorescent green when mixed with water to ensure full rinsing. Tivaclean also contains anti-foaming agents for low sudsing and a deodorant to suppress odor. A biocatalyst is also present for biodegradability and eliminates the need to use toxic chlorinated solvents. In solution, Tivaclean has a non-caustic Ph of 9-10. Tivaclean is also a great ultrasonic cleaner. It can be used at room temperature; however, heating the solution to a temperature between 160°F and 180°F enhances its performance.

Item	Order #	Container Volume	12+	6+	1+
B	54-4401	1 lb	\$6.49	\$6.77	\$7.05

**STULLER SUPERSONIC SOAP**

A special blend of cleaning agents, that produces the ultimate in ultrasonic cleaning. Very effective in removing tripoli, bobbing, and polishing compounds. Highly concentrated, dilute with up to 10 parts water.

Item	Order #	Container Volume	12+	6+	1+
C	54-4447	1 gallon	\$14.03	\$14.64	\$15.25

**PUMP ADAPTER**

D. Pump adapter for five-gallon drum. Heavy-duty pump with angled spout to prevent dripping. Fits 3/4" and 2" openings.

E. Pump adapter for five-gallon drum. Allows for the easy directional dispensing of liquids into receiving container.

Item	Order #	Description	12+	6+	1+
D	54-4458	18" Barrel - 8 oz per stroke	\$51.47	\$54.50	\$60.55
E	54-4439	12" Barrel - 5 oz per stroke	\$32.60	\$34.52	\$38.35

**MAGIC GREEN® ULTRASONIC CLEANING POWDER**

Non-ammoniate, concentrated. Mix one ounce per gallon of water.

Order # 54-44000

Item	Container Volume	12+	6+	1+
F	32 oz	\$19.05	\$20.66	\$22.95
	10 lb (not shown)	\$57.04	\$59.52	\$62.00
	50 lb (not shown)	\$319.84	\$346.82	\$385.35

**MAGIC LUSTER® CLEANING SOLUTION**

This super concentrated ultrasonic cleaner for gold and silver dilutes with up to 40 parts water. Works fast at room temperature and extra fast in heated water. Non-ammoniated.

Item	Order #	Container Volume	12+	6+	1+
G	54-4407	1 gallon	\$16.93	\$18.36	\$20.40
	54-4408	5 gallons (not shown)	\$81.88	\$85.44	\$89.00

JAX® Chemical Company has been manufacturing metal finishing and polishing solutions for more than 40 years. Artisans and craftsmen rely on JAX® for restorations, reproductions, and current work. JAX® is specified by architects and builders for interiors, exteriors, and roofs.



**JAX®**

- A. Produces an antique black finish on brass, bronze and copper.
- B. A rust remover and an effective pre-paint primer for iron and steel.
- C. A heavy-duty cleaner that removes tarnish, surface dirt, old lacquer and grease from brass, bronze and copper, yet is safe for use on gold and marble.
- D. Plates pure silver onto copper, brass, bronze and silver. 4 oz.
- E. Instantly plates copper onto iron, steel, brass and solder.
- F. Produces a dark, black antique finish on silver and gold.
- G. Prevents rust on clean iron and steel.
- H. Produces an antique Flemish, gray-black finish on brass, bronze and copper.
- J. A light-duty cleaner for delicate metals. Removes tarnish and surface contamination from fine gold finishes, bronzes, lamps, lighting fixtures, jewelry and antiques. Contains no abrasives. Leaves no residue.
- K. Chemically cleans and polishes tarnished brass, bronze, copper, pewter, nickel and steel. Removes oxidation, surface dirt, oil and fingerprints.
- L. Produces a dark, black antique finish on pewter, lead, brass, bronze, copper, nickel, tin-lead alloys and solders.
- M. Chemically cleans and polishes the blackest silver in one application. Does not strip surface to a raw, dull finish. Incorporates a special polish that will not harm or streak the most delicate surfaces.
- N. Produces an antique rust finish on iron and steel.
- P. Produces a bright clean finish on all aluminum surfaces.
- Q. Produces an antique brown finish on brass, bronze and copper.
- R. Produces a simulated 24 K Hamilton finish on brass.
- S. Produces a permanent, authentic, antique green finish on copper, brass and bronze.
- T. Produces an antique, metallic black finish in seconds on iron, steel, cast iron and nickel.

Item	Order #	Description	Container Volume	12+	6+	1+
A	54-4720	Jax® Black Darkener	16 oz	\$14.03	\$14.64	\$15.25
B	54-4780	Jax® Rust Remover	16 oz	\$11.45	\$11.95	\$12.45
C	54-4840	Jax® Brass Gold Copper Marble Cleaner	32 oz	\$14.54	\$15.17	\$15.80
D	54-4770	Jax® Silver Plating Solution	4 oz	\$21.39	\$22.32	\$23.25
E	54-4870	Jax® Copper Plating Solution	16 oz	\$13.85	\$14.45	\$15.05
F	54-4740	Jax® Silver Blackener	16 oz	\$14.67	\$15.31	\$15.95
G	54-4790	Jax® Rust Preventer	16 oz	\$11.45	\$11.95	\$12.45
H	54-4730	Jax® Flemish Gray Black	16 oz	\$14.03	\$14.64	\$15.25
J	54-4800	Jax® Brass Gold Copper Cleaner	16 oz	\$10.67	\$11.14	\$11.60
K	54-4820	Jax® Metal Cleaner Polish	16 oz	\$12.70	\$13.25	\$13.80
L	54-4750	Jax® Pewter Blackener	16 oz	\$14.03	\$14.64	\$15.25
M	54-4810	Jax® Silver Cleaner Polish	16 oz	\$12.70	\$13.25	\$13.80
N	54-4830	Jax® Antique Rust Quart	32 oz	\$16.84	\$17.57	\$18.30
P	54-4850	Jax® Aluminum Cleaner	16 oz	\$11.45	\$11.95	\$12.45
Q	54-4700	Jax® Brown Darkener	16 oz	\$14.03	\$14.64	\$15.25
R	54-4710	Jax® Gold Finish	16 oz	\$14.67	\$15.31	\$15.95
S	54-4860	Jax® Green Patina	16 oz	\$14.03	\$14.64	\$15.25
T	54-4760	Jax® Iron Steel Blackener	16 oz	\$14.03	\$14.64	\$15.25

All items are priced at jeweler's cost, are sold each, unless otherwise noted, and are subject to change without notice. Visit [Stuller.com](http://Stuller.com) for our complete product selections, current pricing, and quantity price breaks. | 219



**INSTA-CLEAN**

A nontoxic dip or wipe-on tarnish remover and cleaner for gold, silver, copper, and brass.

Order # 54-44900

Item	Container Volume	12+	6+	1+
A	8 oz	\$4.80	\$5.09	\$5.65
B	16 oz	\$7.06	\$7.65	\$8.50
C	32 oz	\$11.16	\$12.11	\$13.45
D	1 gallon	\$32.79	\$35.55	\$39.50



**HAND CLEANER**

A concentrated hand cleaner specifically designed for the jewelry industry. Contains very little grit with a citrus orange scent. This hand cleaner will remove all polish quickly and easily.

Item	Order #	Container Volume	12+	6+	1+
E	23-0065	1 gallon	\$20.88	\$21.79	\$22.70



**PURE MAGIC**

Cleans jewelry in three to five minutes regardless of how dirty. Just add water to the concentrated dry chemical mixture to obtain 32 oz of full-strength cleaning solution.

Item	Order #	Container Volume	12+	6+	1+
F	54-4470	32 oz	\$13.62	\$14.21	\$14.80



**MYXIS SHINE BRITE**

Formulated for repair facilities, yet safe enough for the retail market. Non-harmful, non-acidic. Shine Brite works remarkably well on the most difficult of jewelry such as mesh and rope chains, diamond bracelets and cluster rings, precious metals, and watch bands. Shine Brite dissolves dirt and grime away completely in warm water or light steam.

Item	Order #	Description	Container Volume	12+	6+	1+
G	54-4478	Jewelry Cleaner	4 oz	\$3.57	\$3.87	\$4.30
H	54-4479	Jewelry Cleaner	8 oz	\$4.98	\$5.40	\$6.00



**QUICK-CLEAN CLEANER**

The quickest, easiest, and most effective way to clean your jewelry at home. Our Quick-Clean system is a fully contained foam with an agitating chamber that protects jewelry while efficiently removing soil. The fill line of the liquid cleaner is below the bottom of the agitating chamber. A riser/drain feature supports the agitating chamber and allows the cleaning solution to flow into the agitating chamber during cleaning.

Item	Order #	Description	Container Volume	12+	6+	1+
J	54-4520	Quick-Clean	8 oz	\$6.30	\$6.58	\$6.85



**STULLER TARNISH REMOVER**

Dip and rinse to instantly remove tarnish from silver. Note: Ingredients deteriorate with use and can cause tarnish. Fresh solution corrects the problem.

Item	Order #	Container Volume	12+	6+	1+
K	54-4444	1 gallon	\$28.52	\$30.20	\$33.55

**INFUSED SPONGES**

Designed for the showroom. Cleans better than paper towels. Lightly spray glass with cleaner and wipe for a squeaky-clean. No more fingerprints. Convenient to use and specially built for repeat use, this user-friendly shape and compact size fits perfectly into hand and wastes little space when storing. Made from plant-based renewable resources, the infused sponge reduces unnecessary paper towel use, saving money and sustaining the Earth's resources.

Order #	Description	12+	6+	1+
23-0001	Showcase Glass Cleaning Sponge	\$4.19	\$4.37	\$4.55



**INFUSED SPONGES**

Designed for the shop. Infused with powerful degreasing soap with pumice and up to 40 times stronger than the leading sponge, this sponge replaces the scrubbing brush. It removes rouge from the skin like a magnet, and it doesn't hurt your hands. Specifically designed for repeat use, this infused sponge does not support bacteria, allowing it to maintain its freshness. Made from plant-based renewable resources.

Order #	Description	12+	6+	1+
23-0002	Lava Soap Infused	\$4.19	\$4.37	\$4.55



**PR88 HAND PROTECTION**

Excellent hand protection keeps grease and grime from penetrating the skin. Just apply before beginning work. Washes off with soap and water.

Order # 54-4462

Item	Container Volume	12+	6+	1+
A	3½ oz	\$9.15	\$9.55	\$9.95
B	1 liter	\$30.65	\$29.42	\$28.20



**BLUE MAGIC INVISIBLE GLOVE**

Hand coating protects hands from rouge, grease, oil, and even paint. Easy clean-up with soap and water. Not greasy. Actually improves grip on tools.

Order #	Container Volume	12+	6+	1+
54-4468	2½ oz	\$6.30	\$6.58	\$6.85



**BAMBOO TWEEZERS**

Tweezers made from bamboo have a gentle grip and will not damage small delicate objects. Bamboo tweezers are highly recommended for use in optical inspection and production environments. They have excellent insulation and are chemical-resistant.

Order # 57-75170

Item	Description	Length	12+	6+	1+
C	Small Pointed	6"	\$4.04	\$4.28	\$4.75
D	Large Pointed	9 7/8"	\$4.21	\$4.46	\$4.95
E	Large Flat Blunt	7"	\$4.89	\$5.18	\$5.75



**COATED FORCEPS/STEAM TWEEZERS**

Use for handling items being steamed and/or cleaned in ultrasonics. Plastic coating on tips provide chemical resistance along with a firm grip for retrieving items without scratching. Made of nickel-plated steel. Plastic coating may vary in color.

Order # 57-75100

Item	Description	Length	12+	6+	1+
F	Cross-Locking	6 ½"	\$9.99	\$10.58	\$11.75
G	Straight	8"	\$9.35	\$9.90	\$11.00
H	Straight	10"	\$10.20	\$10.80	\$12.00







**ECONOMICAL STEAM TWEEZERS**

Chrome-plated steam tweezers feature chemical resistant plastic coating on tips. Plastic coating may vary in color.

Order #	Description	Length	12+	6+	1+
57-9200	Steam Tweezers	11"	\$6.16	\$6.53	\$7.25



**STEAMOSTAT**

Made of stainless steel, the Steamostat features PVC-covered tips for holding jewelry while steam cleaning.

Order #	Description	Length	12+	6+	1+
46-4555	Steamostat	8"	\$9.78	\$10.35	\$11.50



**HEMOSTAT FORCEPS**

Use as clamps when working with small articles. Made of stainless steel, these forceps feature box-joint construction and their serrated jaws allow firm holding. Contains three-position locking device.

Order # 46-45450

Item	Description	Length	12+	6+	1+
A	Straight Forceps	5"	\$5.74	\$6.08	\$6.75
B	Curved Forceps	5"	\$5.53	\$5.85	\$6.50

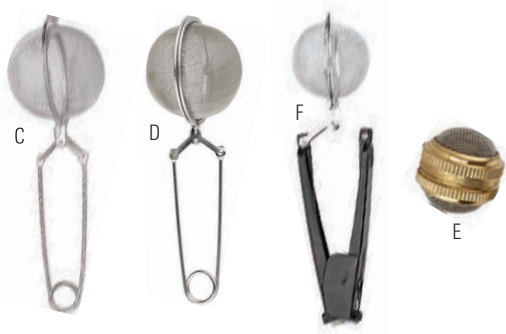

**PARTS HOLDING BASKET**

Baskets used for keeping small parts together in ultrasonics or steam cleaners. Springs apart for quick unloading.

Item	Order #	Description	Basket	Length	12+	6+	1+
C	23-1000	Small Basket	1½"	6½"	\$4.04	\$4.28	\$4.75
D	23-1010	Large Basket	2"	6"	\$3.87	\$4.10	\$4.55
E	23-1012	Large Brass Basket		1"	\$5.40	\$5.72	\$6.35
F	23-1015	Small Basket with Handle	5¾"		\$4.04	\$4.28	\$4.75
	23-1020	Large Basket with Handle	5¾"		\$4.25	\$4.50	\$5.00
	23-1022	Small Brass Parts Basket	¾"		\$6.29	\$6.66	\$7.40



**CLEANING BASKET**

Stainless steel cleaning baskets are universal. With practical side clips, they can be used with smaller and larger units.

Item	Order #	LxWxD	Mesh	Fits Tank	12+	6+	1+
G	23-5915	5"x4"x1 ¾"	Fine	2 qt.	\$10.84	\$11.48	\$12.75
H	23-5920	5½"x4½"x1½"	Extra-Fine	2 qt.	\$14.07	\$14.90	\$16.55
J	23-6200	5½"x2½"x1½"	Fine	1 pt.	\$24.31	\$25.74	\$28.60
K	23-6209	5¼"x5"x3½"	Extra-Fine	2 qt.	\$14.41	\$15.26	\$16.95
L	23-6210	9"x5"x3½"	Medium	3 qt.	\$15.30	\$16.20	\$18.00
M	23-6212	2½"x2½"	Fine	2 qt.	\$6.76	\$7.16	\$7.95
N	23-6211	7½"x3"	Fine	1 pt.	\$3.36	\$3.56	\$3.95



**ULTRASONIC PARTS BASKET**

Fine, plastic mesh mounted on plastic legs to keep basket away from bottom of ultrasonic and will prevent even your smallest stone from being lost. Has up to 16 hanging hooks. Great for use with chains. Basket has convenient handle for easy removal.

Order #	Description	Height	Depth	12+	6+	1+
23-2000	Parts Basket	3¾"	4¾"	\$16.58	\$17.55	\$19.50

**PLASTIC STRAINERS**

Plastic strainers with nylon mesh are great for many uses. Nylon will not scratch jewelry and is perfect for dipping jewelry.

Item	Order #	Description	Width	Depth	12+	6+	1+
A	23-5900	Small Basket	2¾"	2½"	\$1.62	\$1.71	\$1.90
B	23-5905	Large Basket	9"	2½"	\$2.59	\$2.75	\$3.05



**ULTRASONIC RING RACKS**

Fits one- and two-quart ultrasonics lengthwise and three-, six-, and ten-quart tanks crosswise. Plastic-coated, rust-resistant hook and bar racks increase ultrasonic cleaning efficiency and will not mar objects.

Order # 23-10300

Item	Description	Length	12+	6+	1+
C	Coated Rack - No Legs		\$3.61	\$3.83	\$4.25
D	Coated Double Rack with Legs		\$6.29	\$6.66	\$7.40
E	8 Hooks (16 Rings)	12"	\$7.40	\$7.83	\$8.70
F	12 Hooks (24 Rings)	14½"	\$8.08	\$8.55	\$9.50
G	Replacement Hooks - pack of 5		\$3.87	\$4.10	\$4.55

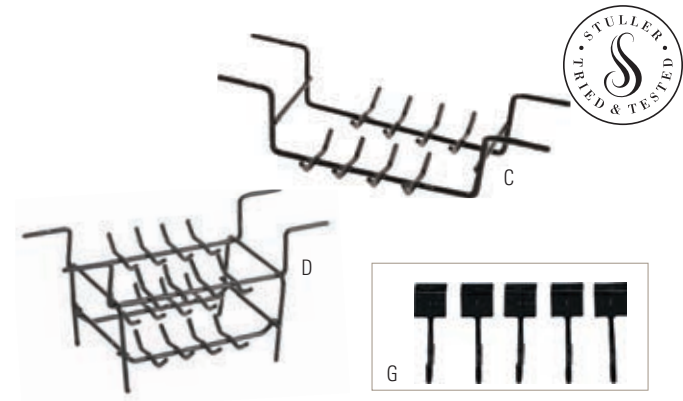

Rings not included

**STONE WASHER**

Clean loose stones with a glass container for washing.

Order #	Description	12+	6+	1+
64-4010	Stone Washer	\$7.11	\$8.12	\$10.15





**MAGIC DRAIN TRAP**

See-through trap can save all kinds of valuables. Easy, snap-off filter is easily removed to recover lost items. Magic drain is all plastic and resists corrosion. Easy to install. Hardware included.

Order #	Description	12+	6+	1+
23-6015	Magic Drain Trap	\$14.41	\$15.26	\$16.95



**STONE SAVER**

This new style of drain trap for jewelry trade shops is made with fine mesh that prevents anything larger than 0.5 millimeters across from falling into the drain. Magnetic ring provides a secure seal to metal drains. Works with any standard 4½" metal sink drain. No installation required.

Order #	Description	12+	6+	1+
51-1000	Stone Saver	\$11.36	\$11.86	\$12.35



**GOLD RECOVERY SYSTEM**

Don't let money get washed down the drain. Install a drain sweeper kit under your sink and capture all your precious metal sweeps. The kit is easily installed with the included fittings and instructions—no need for a plumber in most cases. Catch particles as small as five microns. Filter cartridges are easily changed out in a matter of a couple minutes with no mess. This is a must-have for any repair room or manufacturing facility. Uses 1" inside diameter PVC pipe.

Item	Order #	Description	W×L	12+	6+	1+
A	23-6020	Drain Sweeper Kit	4½"×13¾"	—	—	\$189.75
B	23-6021	Replacement Filter		\$5.99	\$6.35	\$7.05

**KLEAN KARATS® POLISHING CLOTHS**

Each cloth is bathed in a patented, nontoxic formula that effectively cleans and protects your investment. It renews the shine on your gold, platinum, and silver inventory. The cloth also creates an effective anti-tarnish shield that helps maintain shine and brilliance longer.

- Free personalization with the purchase of 200 cloths.
- A \$35, one-time set-up charge will be assessed on the initial order.
- Shipped within three weeks, upon approval of your supplied camera-ready artwork.



Order #	Description	W×L	200 Cloths	10 Cloths	1 Cloth
17-0786	Treated Cloth w/Envelope	8"×8"	\$1.97	\$2.02	\$2.29
17-0788	Treated Cloth (50 pack)	8"×8"	\$67.94	\$69.52	\$79.00
17-0780	Chamois-Untreated Cloth w/Envelope	8"×8"	\$1.88	\$1.93	\$2.19
17-0798	Chamois-Untreated Cloth (50 Pack)	8"×8"	\$59.34	\$60.72	\$69.00
17-0790	Treated Cloth w/Envelope	4"×4"	\$1.16	\$1.19	\$1.35
17-0792	Treated Cloth (50 pack)	4"×4"	\$30.10	\$30.80	\$35.00

**Ink Color Choices**

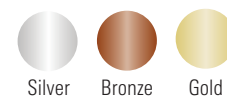

For more options visit [Stuller.com/CustomImprinting](http://Stuller.com/CustomImprinting).



Find added video content on [Stuller.com/VideoCenter](http://Stuller.com/VideoCenter).

Learn more at [Stuller.com/BuildYourBrand](http://Stuller.com/BuildYourBrand).



**KLEAN KARATS® JEWELRY CLEANERS**

Return shine and brilliance to your customers' entire jewelry wardrobe with our Klean Karats jewelry solutions. Our four specially formulated products cleanse, polish, and revive all of your jewelry pieces. Choose from Silver, Fine, Gentle, and Natural. Sold in packs of 12.



Item	Order #	Description	Size	1+
A	17-0881	Fine	6 oz.	\$29.99
B	17-0882	Gentle	6 oz.	\$29.99
C	17-0883	Silver	6 oz.	\$29.99
D	17-0884	Natural	6 oz.	\$29.99
E	54-4097	Ring Remover	1 oz.	\$33.00

**KLEAN KARATS® RING REMOVER**

This formula is designed to help slip your ring on and off while also being fast-drying that doesn't dull or gum fine jewelry. (sold in packs of 12)

**CUSTOM IMPRINTED CLEANERS**

Brand with your store name to create an add-on sale that will constantly serve as a visual reminder of your store. Customizing your Klean Karats is easy. Send us your digital artwork as an .ai, .eps, or .tif format with a minimum resolution of 300 dpi (600 dpi preferred).

- Lead time is four weeks
- One-time set up charge is \$60
- 144 six-ounce jars (\$315)
- 72 four-ounce jars (\$175)

Choose your jar color, cap color, and liquid color from the chart below for a more customized cleaner at no extra charge.



**Liquid Colors**



**Jar colors**

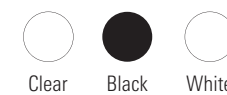

**Cap colors**

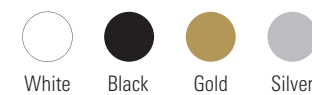

**Ink colors**





# DRILLS AND PUNCHES

## Preform SIZING SYSTEM



Find added video content on [Stuller.com/VideoCenter](http://Stuller.com/VideoCenter).



### PREFORM® SIZING SYSTEM

This revolutionary sizing stock is strong, fast, and easy to use.

Invented at Stuller as a way of improving our own large scale sizing operations, Preform sizing stock is pre-bent to the radius of the ring in question and rounded to provide a flush fit with the shank. This allows for more efficient, quick soldering and results in perfectly fitted, gap-free joints that will endure the test of time.

Easy to master and effortless to implement, Preform comes in precisely calibrated half-size increments. Try it today and take the guesswork and extra effort out of ring sizing forever.



### PREFORM® DRILL PRESS

The drill press is used to center and guide the drill bit when preparing the mounting to accept the Preform stock. It is designed to work with all five sizes of mill bits. Handpiece sold separately.

Item	Order #	Description	12+	6+	1+
A	48-1036	Preform® Drill Press	—	—	\$154.76
B	48-1046	Drill Kit	\$57.93	\$61.34	\$68.15

#### Order # 48-10430

Item	Description	OD	12+	6+	1+
C	Carbide End Mill Drill	1mm	\$17.76	\$18.53	\$19.30
D	Carbide End Mill Drill	1.2mm	\$17.76	\$18.53	\$19.30
E	Carbide End Mill Drill	1.5mm	\$17.76	\$18.53	\$19.30
F	Carbide End Mill Drill	1.75mm	\$17.76	\$18.53	\$19.30
G	Carbide End Mill Drill	2mm	\$17.76	\$18.53	\$19.30
	Carbide End Mill Drill	2.5mm	\$17.76	\$18.53	\$19.30



Find added video content on [Stuller.com/VideoCenter](http://Stuller.com/VideoCenter).



Handpiece is sold separately.  
Item # 34-2215

### PREFORM® SIZING SYSTEM — HOW IT WORKS



**STEP 1:** Measure width of shank to determine PREFORM sizing stock needed.



**STEP 2:** Select proper drill bit. Position shank. Center bottom of shank by eye. Use wheel to drive into shank.



**STEP 3:** Open the shank on your mandrel ¼ size from size needed.



**STEP 4:** Snap the PREFORM into place.



**STEP 5:** Solder using your traditional soldering methods.

All items are priced at jeweler's cost, are sold each, unless otherwise noted, and are subject to change without notice. Visit [Stuller.com](http://Stuller.com) for our complete product selections, current pricing, and quantity price breaks. | 227





A. This easy-to-use benchtop drill press is tiny, but powerful enough to use for all of your drilling projects. With a platform measuring only 6¾" x 6¾", it is space saving as well as economical.

- 110-120V
- Accepts ⅛" to ¼" drills
- 100 Watts

B. Superlube is a multipurpose, synthetic, nontoxic, non-polluting, and non-corrosive lubricant with Teflon particles. It does not harm plastic.

Item	Order #	Description	Size	12+	6+	1+
A	28-0686	Bench Top Drill Press		\$63.75	\$67.50	\$75.00
B	26-3879	Synthetic Lubricant	¼ oz	—	—	\$13.60

**FOREDOM**



**FOREDOM® DRILL PRESS**

A rugged and precise stand that converts your flexible shaft unit into a precision drill press and milling tool. The sturdy, all-metal stand is fully adjustable, has a 2" throat capacity, and a stroke length of up to 1¼". The work holding table moves up and down or can be swung away for drilling large pieces. Designed for use with No. 30, No. 30H, No. 44, No. 44T, and No. 44HT handpieces. The DP39 comes with a dial indicator measuring in millimeters for setting, drilling, or cutting depth. Graduated by 1/100 mm.

Item	Order #	Description	12+	6+	1+
C	34-6302	DP30 Drill Press	\$149.43	\$158.22	\$175.80

**METAL VISE**

Zinc, die-cast, mini vise firmly grasps small work pieces for precision drilling. Has horizontal and vertical V grooves for holding small round pieces. Use with DP30, item 34-6302.

Item	Order #	Description	Width	ID	12+	6+	1+
D	34-6301	Metal Vise	1⅞"	1 ¼"	\$21.46	\$22.73	\$25.25



**FOREDOM® DRILL VISE**

Plastic mini vise is great for holding gemstones and other materials that require water during the drilling process.

Item	Order #	Description	Width	ID	12+	6+	1+
E	58-2434	Drill Vise	¾"	1 ⅝"	\$16.83	\$17.82	\$19.80

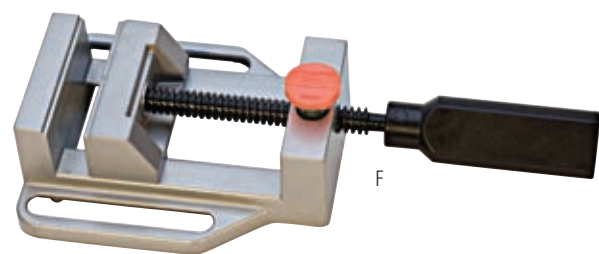

**DRILL PRESS VISE**

This handy aluminum drill press vise is great for use with our tabletop drill press (28-0686). Vise has slots and hardware included for optional attachment to drill press base. Its quick release feature permits rapid opening and closure of the jaws or use the handle to make smaller adjustments.

Item	Order #	Description	Width	Jaw Size	12+	6+	1+
F	28-0687	Drill Press Vise	4½"	2½ x 1⅞"	\$12.16	\$12.87	\$14.30

**PEARL DRILL MACHINE**

High-precision drill, specifically designed to drill pearls from 3mm to 20mm without any chipping or cracking of the pearls. The compact unit includes a drill chuck, a self-centering vise to hold the pearls securely while drilling, and a 6,000 RPM motor. Comes with brass pearl holders from 3mm to 7mm.

Item	Order #	Description	1+
A	28-0700	Pearl Drilling Machine	\$404.60
B	28-0705	Carbon Brushes with Caps	\$13.20

**Order # 28-07000 BRASS PEARL HOLDERS**

OD	1+	OD	1+	OD	1+
5mm	\$37.45	11mm	\$46.35	16mm	\$46.35
6mm	\$37.45	12mm	\$46.35	17mm	\$52.50
7mm	\$37.45	13mm	\$46.35	18mm	\$52.50
8mm	\$37.45	14mm	\$46.35	19mm	\$52.50
9mm	\$37.45	15mm	\$21.25	20mm	\$21.25
10mm	\$46.35				



**SET OF PEARL DRILLS**

Use to drill holes in seed pearls and round and half-round stones to aid in the setting process.

**Order # 53-12000**

OD	12+	6+	1+	OD	12+	6+	1+	OD	12+	6+	1+
1.05mm	\$6.21	\$6.48	\$6.75	1.65mm	\$6.21	\$6.48	\$6.75	2.26mm	\$6.21	\$6.48	\$6.75
1.2mm	\$6.21	\$6.48	\$6.75	1.85mm	\$6.21	\$6.48	\$6.75	2.4mm	\$6.21	\$6.48	\$6.75
1.45mm	\$6.21	\$6.48	\$6.75	2.05mm	\$6.21	\$6.48	\$6.75	3.0mm	\$6.21	\$6.48	\$6.75

**12-Piece Kit Order # 53-1200**

Item	Description	12+	6+	1+
C	1.0mm-3.0mm Pearl Drill Set	\$75.85	\$79.15	\$82.45



**HIGH-SPEED PEARL DRILLS**

D. High-speed pearl drills are double ended. They are specially shaped to drill an accurate hole without chipping.

**Order # 28-07300**

OD	12+	6+	1+	OD	12+	6+	1+	OD	12+	6+	1+
0.6mm	\$4.89	\$5.18	\$5.75	1.0mm	\$4.89	\$5.18	\$5.75	1.5mm	\$14.49	\$15.12	\$15.75
0.7mm	\$4.89	\$5.18	\$5.75	1.2mm	\$4.89	\$5.18	\$5.75	1.6mm	\$14.67	\$15.31	\$15.95
0.8mm	\$4.89	\$5.18	\$5.75	1.3mm	\$4.89	\$5.18	\$5.75	1.7mm	\$20.88	\$21.79	\$22.70
0.9mm	\$4.89	\$5.18	\$5.75	1.4mm	\$4.89	\$5.18	\$5.75				



**PEARL DRILL VISE**

E. Holds pearls in place while drilling. Allows you to half-drill pearls and beads or open obstructed or imperfect holes. Features a 1mm, drill guide (#60 drill).

Order #	Description	12+	6+	1+
53-1201	Pearl Drill Vise	\$16.15	\$17.10	\$19.00

**PEARL HOLDING VISE**

F. Holds pearls securely for drilling. 13 holes (2-10mm).

Order #	Description	12+	6+	1+
53-1203	Pearl Holding Vise	\$5.53	\$5.85	\$6.50



**BUSCH® PEARL DRILLS**

G. Drill holes in pearls and other round to half-round stones for stone setting. ⅜" shank.

**Order # 28-07510**

OD	12+	6+	1+	OD	12+	6+	1+	OD	12+	6+	1+
0.9mm	\$4.46	\$4.73	\$5.25	1.4mm	\$4.46	\$4.73	\$5.25	2.3mm	\$4.46	\$4.73	\$5.25
1mm	\$4.46	\$4.73	\$5.25	1.6mm	\$4.46	\$4.73	\$5.25	2.5mm	\$4.83	\$5.04	\$5.25
1.2mm	\$4.46	\$4.73	\$5.25	2.1mm	\$4.46	\$4.73	\$5.25				

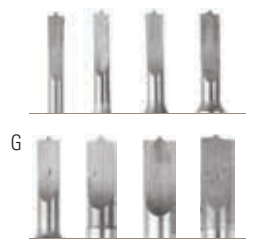

**Busch**



**HIGH-SPEED TWIST DRILLS**

These high-speed drills are top-quality, precision-ground tempered steel. The drills are able to drill into metal as well as stone. A uniform, medium shank size speeds up tool changes.

**Order # 28-10000**

Material High-Speed Steel  
Shank Size Will vary  
Sold in packs of 10

mm	1.778	1.702	1.613	1.512	1.397	1.321	1.181	1.092
Drill #	#50	#51	#52	#53	#54	#55	#56	#57
12+	\$4.56	\$4.56	\$4.56	\$4.56	\$4.56	\$4.56	\$4.56	\$4.56
6+	\$5.13	\$5.13	\$5.13	\$5.13	\$5.13	\$5.13	\$5.13	\$5.13
1+	\$5.70	\$5.70	\$5.70	\$5.70	\$5.70	\$5.70	\$5.70	\$5.70

mm	1.067	1.041	1.016	0.99	0.965	0.94	0.914	0.889
Drill #	#58	#59	#60	#61	#62	#63	#64	#65
12+	\$4.56	\$4.56	\$4.56	\$4.56	\$4.56	\$4.56	\$4.56	\$4.56
6+	\$5.13	\$5.13	\$5.13	\$5.13	\$5.13	\$5.13	\$5.13	\$5.13
1+	\$5.70	\$5.70	\$5.70	\$5.70	\$5.70	\$5.70	\$5.70	\$5.70

mm	0.838	0.813	0.787	0.734	0.712	0.66	0.635	0.61
Drill #	#66	#67	#68	#69	#70	#71	#72	#73
12+	\$4.56	\$4.56	\$4.56	\$4.56	\$4.56	\$4.56	\$4.56	\$4.56
6+	\$5.13	\$5.13	\$5.13	\$5.13	\$5.13	\$5.13	\$5.13	\$5.13
1+	\$5.70	\$5.70	\$5.70	\$5.70	\$5.70	\$5.70	\$5.70	\$5.70

mm	0.572	0.533	0.508	0.457	0.406	0.369	0.343
Drill #	#74	#75	#76	#77	#78	#79	#80
12+	\$4.56	\$4.56	\$4.56	\$4.56	\$4.56	\$4.56	\$4.56
6+	\$5.13	\$5.13	\$5.13	\$5.13	\$5.13	\$5.13	\$5.13
1+	\$5.70	\$5.70	\$5.70	\$5.70	\$5.70	\$5.70	\$5.70

**Kit Order # 28-5040**

Item	Description	Size	12+	6+	1+
A	36-Piece Assortment	#33-#80	\$45.72	\$47.71	\$49.70

**Kit Order # 28-10000**

Item	Description	12+	6+	1+
B	100-Piece Assortment #61-#70	\$42.75	\$46.35	\$51.50
C	100-Piece Assortment #71-#80	\$42.75	\$46.35	\$51.50
D	200-Piece Assortment #61-#80	\$83.58	\$87.22	\$90.85



**COBALT TWIST DRILLS**

**Order # 28-0681**

Material Cobalt Steel  
Shank Size Will vary  
Sold Each

mm	0.5	0.6	0.7	0.8	0.9	1.0	1.1	1.2
12+	\$4.34	\$4.34	\$4.34	\$4.34	\$4.34	\$4.34	\$4.34	\$4.34
6+	\$4.59	\$4.59	\$4.59	\$4.59	\$4.59	\$4.59	\$4.59	\$4.59
1+	\$5.10	\$5.10	\$5.10	\$5.10	\$5.10	\$5.10	\$5.10	\$5.10

mm	1.3	1.4	1.5	1.6	1.7	1.8	1.9	2.0
12+	\$4.34	\$4.34	\$4.34	\$4.34	\$4.34	\$4.34	\$4.34	\$4.34
6+	\$4.59	\$4.59	\$4.59	\$4.59	\$4.59	\$4.59	\$4.59	\$4.59
1+	\$5.10	\$5.10	\$5.10	\$5.10	\$5.10	\$5.10	\$5.10	\$5.10

mm	2.1	2.2	2.3
12+	\$4.34	\$4.34	\$4.34
6+	\$4.59	\$4.59	\$4.59
1+	\$5.10	\$5.10	\$5.10

**Kit Order # 28-0681**

Description	Size	12+	6+	1+
10-Piece Kit	0.5mm-2.2mm	\$37.66	\$39.87	\$44.30
6-Piece Kit	0.5mm-2.0mm	\$21.33	\$23.13	\$25.70



**Order # 28-10001**

Material High-Speed Steel  
Shank Size Will vary  
Sold in packs of 10

mm	1.78	1.7	1.51	1.397	1.18	1.092	1.067	1.041
Drill #	#50	#51	#52	#54	#55	#57	#58	#59
12+	\$17.71	\$17.71	\$17.71	\$17.71	\$17.71	\$17.71	\$17.71	\$17.71
6+	\$18.48	\$18.48	\$18.48	\$18.48	\$18.48	\$18.48	\$18.48	\$18.48
1+	\$19.25	\$19.25	\$19.25	\$19.25	\$19.25	\$19.25	\$19.25	\$19.25

mm	1.016	0.99	0.965	0.94	0.914	0.889	0.838	0.813
Drill #	#60	#61	#62	#63	#64	#65	#66	#67
12+	\$17.71	\$17.71	\$17.71	\$17.71	\$17.71	\$17.71	\$17.71	\$17.71
6+	\$18.48	\$18.48	\$18.48	\$18.48	\$18.48	\$18.48	\$18.48	\$18.48
1+	\$19.25	\$19.25	\$19.25	\$19.25	\$19.25	\$19.25	\$19.25	\$19.25

mm	0.787	0.734	0.713	0.66	0.635	0.61	0.572	0.533
Drill #	#68	#69	#70	#71	#72	#73	#74	#75
12+	\$17.71	\$19.83	\$19.83	\$22.91	\$22.91	\$22.91	\$22.91	\$22.91
6+	\$18.48	\$20.69	\$20.69	\$23.90	\$23.90	\$23.90	\$23.90	\$23.90
1+	\$19.25	\$21.55	\$21.55	\$24.90	\$24.90	\$24.90	\$24.90	\$24.90

mm	0.508	0.457	0.45	0.369	0.343
Drill #	#76	#77	#78	#79	#80
12+	\$22.91	\$22.91	\$28.11	\$28.11	\$28.11
6+	\$23.90	\$23.90	\$29.33	\$29.33	\$29.33
1+	\$24.90	\$24.90	\$30.55	\$30.55	\$30.55



**Kit Order # 28-0540**

Description	Size	12+	6+	1+
20-Piece Assortment	#61-#81	\$44.85	\$46.80	\$48.75

**Order # 28-0682**

Material Cobalt Steel  
Shank Size Will vary  
Sold in packs of 5

mm	1.78	1.51	1.18	1.09	1.02	0.94	0.91	0.81
Drill #	#50	#53	#56	#57	#60	#63	#64	#67
12+	\$7.44	\$7.44	\$7.44	\$7.44	\$7.44	\$7.44	\$7.44	\$7.44
6+	\$7.88	\$7.88	\$7.88	\$7.88	\$7.88	\$7.88	\$7.88	\$7.88
1+	\$8.75	\$8.75	\$8.75	\$8.75	\$8.75	\$8.75	\$8.75	\$8.75

mm	0.91	0.74	0.71	0.64	0.61
Drill #	#64	#69	#70	#72	#73
12+	\$7.44	\$7.44	\$7.44	\$7.44	\$7.44
6+	\$7.88	\$7.88	\$7.88	\$7.88	\$7.88
1+	\$8.75	\$8.75	\$8.75	\$8.75	\$8.75



**Kit Order # 28-0688**

Description	Size	12+	6+	1+
50-Piece Assortment	#50-#76	\$51.29	\$55.62	\$61.80

**DORMER HIGH-SPEED TWIST DRILLS**

Straight-shank, high-speed, steel twist drills are made of high-quality steel. Last two digits equal drill number.



**TITANIUM-COATED TWIST DRILLS**

A professional and ideal solution to demanding drilling needs, the titanium coating allows the bits to withstand high temperatures by reducing friction. This leads to increased wear resistance.



PRIMO® HIGH-SPEED TWIST DRILLS



Order # 10-8324

Material Steel  
Shank Size 3/32"  
Sold in packs of 3



mm	0.5	0.7	0.9	1.0	1.2	1.4	1.6	1.8	2.0	2.2
Drill #	#76	#70	#65	#57	#56	#54	#52	#50	#46	#43
12+	\$7.41	\$7.41	\$7.41	\$7.41	\$7.41	\$7.41	\$7.41	\$7.41	\$7.41	\$7.41
6+	\$7.73	\$7.73	\$7.73	\$7.73	\$7.73	\$7.73	\$7.73	\$7.73	\$7.73	\$7.73
1+	\$8.05	\$8.05	\$8.05	\$8.05	\$8.05	\$8.05	\$8.05	\$8.05	\$8.05	\$8.05

Kit Order # 10-8324

27-Piece Bur Kit (1 each)  
.5mm-2.2mm

12+	\$7.41
6+	\$7.73
1+	\$8.05

PRIMO® HIGH-SPEED TITANIUM COATED TWIST DRILLS



Order # 10-8325

Material Steel  
Shank Size 3/32"  
Sold in packs of 3



mm	0.5	0.7	0.9	1.1	1.2	1.4	1.6	1.8	2.0	2.2
Drill #	#76	#70	#65	#57	#56	#54	#52	#50	#46	#43
12+	\$8.23	\$8.23	\$8.23	\$8.23	\$8.23	\$8.23	\$8.23	\$8.23	\$8.23	\$8.23
6+	\$8.59	\$8.59	\$8.59	\$8.59	\$8.59	\$8.59	\$8.59	\$8.59	\$8.59	\$8.59
1+	\$8.95	\$8.95	\$8.95	\$8.95	\$8.95	\$8.95	\$8.95	\$8.95	\$8.95	\$8.95

Kit Order # 10-8325

10-Piece Assortment (1 each)  
.5mm-2.2mm

12+	\$8.23
6+	\$8.59
1+	\$8.95

PRIMO® HIGH-SPEED STEEL TITANIUM-COATED TWIST DRILLS

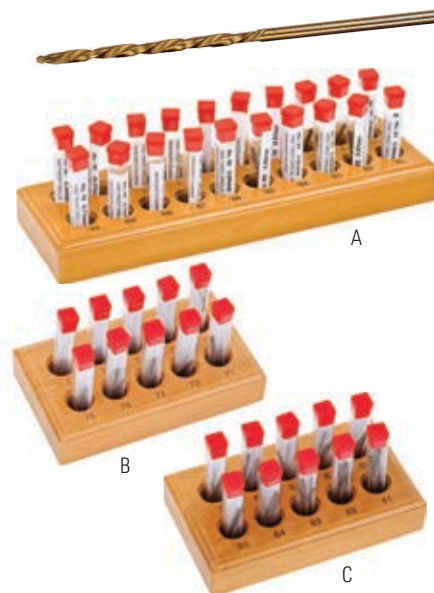

Order # 10-8330

Material Steel  
Shank Size 3/32"  
Sold Each

mm	0.99	0.97	0.94	0.91	0.89	0.84	0.81	0.79	0.73	0.71
Drill #	#61	#62	#63	#64	#65	#66	#67	#68	#69	#70
12+	\$6.44	\$6.44	\$6.44	\$6.44	\$6.44	\$6.44	\$6.44	\$6.44	\$6.44	\$6.44
6+	\$6.72	\$6.72	\$6.72	\$6.72	\$6.72	\$6.72	\$6.72	\$6.72	\$6.72	\$6.72
1+	\$7.00	\$7.00	\$7.00	\$7.00	\$7.00	\$7.00	\$7.00	\$7.00	\$7.00	\$7.00

Kit Order # 10-8330

A. Set of 100 (5 each) #61-80  
B. Set of 50 (5 each) #61-70  
C. Set of 50 (5 each) #71-80

12+	\$72.54	\$38.23	\$38.23
6+	\$75.70	\$39.89	\$39.89
1+	\$78.85	\$41.55	\$41.55

mm	0.66	0.64	0.61	0.57	0.53	0.51	0.46	0.41	0.37	0.34
Drill #	#71	#72	#73	#74	#75	#76	#77	#78	#79	#80
12+	\$6.44	\$6.44	\$6.44	\$6.44	\$6.44	\$6.44	\$6.44	\$6.44	\$6.44	\$6.44
6+	\$6.72	\$6.72	\$6.72	\$6.72	\$6.72	\$6.72	\$6.72	\$6.72	\$6.72	\$6.72
1+	\$7.00	\$7.00	\$7.00	\$7.00	\$7.00	\$7.00	\$7.00	\$7.00	\$7.00	\$7.00

PREMIUM GOLD COBALT TWIST DRILLS

Order # 28-06600

Material Cobalt Steel  
Shank Size 3/32"  
Sold in pack of 10



mm	1.78	1.70	1.61	1.51	1.40	1.32	1.18
Drill #	#50	#51	#52	#53	#54	#55	#56
12+	\$7.78	\$7.78	\$7.78	\$7.78	\$7.78	\$7.78	\$7.78
6+	\$8.24	\$8.24	\$8.24	\$8.24	\$8.24	\$8.24	\$8.24
1+	\$9.15	\$9.15	\$9.15	\$9.15	\$9.15	\$9.15	\$9.15

mm	1.10	1.07	1.04	1.02	0.99	0.97	0.94
Drill #	#57	#58	#59	#60	#61	#62	#63
12+	\$7.78	\$7.78	\$7.78	\$7.78	\$7.78	\$7.78	\$7.78
6+	\$8.24	\$8.24	\$8.24	\$8.24	\$8.24	\$8.24	\$8.24
1+	\$9.15	\$9.15	\$9.15	\$9.15	\$9.15	\$9.15	\$9.15

mm	0.91	0.90	0.84	0.81	0.79	0.73	0.71
Drill #	#64	#65	#66	#67	#68	#69	#70
12+	\$7.78	\$7.78	\$7.78	\$7.78	\$7.78	\$7.78	\$7.78
6+	\$8.24	\$8.24	\$8.24	\$8.24	\$8.24	\$8.24	\$8.24
1+	\$9.15	\$9.15	\$9.15	\$9.15	\$9.15	\$9.15	\$9.15



Kit Order # 77-2507

30-Piece Assortment (3 each)  
.89mm-2.71mm

Order # 77-2507

Material Steel  
Shank Size 3/32"  
Sold in packs of 5



12+	\$7.35
6+	\$7.79
1+	\$8.65

mm	2.71	2.49	2.08	1.99	1.78	1.70	1.61	1.51
Drill #	#36	#40	#45	#47	#50	#51	#52	#53
12+	\$7.35	\$7.35	\$7.35	\$7.35	\$7.35	\$7.35	\$7.35	\$7.35
6+	\$7.79	\$7.79	\$7.79	\$7.79	\$7.79	\$7.79	\$7.79	\$7.79
1+	\$8.65	\$8.65	\$8.65	\$8.65	\$8.65	\$8.65	\$8.65	\$8.65

mm	1.40	1.18	0.99	0.89
Drill #	#54	#56	#61	#65
12+	\$7.35	\$7.35	\$7.35	\$7.35
6+	\$7.79	\$7.79	\$7.79	\$7.79
1+	\$8.65	\$8.65	\$8.65	\$8.65



PRIMO® COBALT PILOT TWIST DRILL ASSORTMENT

Solid cobalt, double ended pilot drills provide an optimal pinpoint location to mark the area to be drilled.

Order #	Description	12+	6+	1+
10-8326	Pilot Twist Drill Assortment (0.5mm, 1.0mm, 1.5mm)	\$15.69	\$16.37	\$17.05

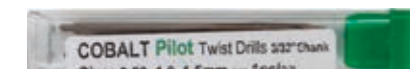





Swiss-made medium-fine grit twist drills are the ultimate choice for drilling stones, pearls, glass, or ceramics. Use with standard handpieces and a small amount of water as lubricant.

**PANTHER® TUNGSTEN CARBIDE TWIST DRILL FIG. #H203**



**Order # 28-10004**

Material Tungsten Carbide Steel  
Shank Size 3/32"  
Sold in packs of 6

mm	0.5	0.6	0.7	0.8	0.9	1.0	1.1	1.2	1.3	1.4
Drill #	#005	#006	#007	#008	#009	#010	#011	#012	#013	#014
12+	\$38.32	\$38.32	\$38.32	\$38.32	\$38.32	\$38.32	\$38.32	\$38.32	\$38.32	\$38.32
6+	\$39.98	\$39.98	\$39.98	\$39.98	\$39.98	\$39.98	\$39.98	\$39.98	\$39.98	\$39.98
1+	\$41.65	\$41.65	\$41.65	\$41.65	\$41.65	\$41.65	\$41.65	\$41.65	\$41.65	\$41.65

mm	1.5	1.6	1.7	1.8	1.9	2.0	2.1	2.3
Drill #	#015	#016	#017	#018	#019	#020	#021	#023
12+	\$38.32	\$38.32	\$38.32	\$38.32	\$38.32	\$38.32	\$38.32	\$38.32
6+	\$39.98	\$39.98	\$39.98	\$39.98	\$39.98	\$39.98	\$39.98	\$39.98
1+	\$41.65	\$41.65	\$41.65	\$41.65	\$41.65	\$41.65	\$41.65	\$41.65



**PANTHER® TUNGSTEN CARBIDE TWIST DRILL FIG. #77**



**Order # 28-10003**

Material Tungsten Carbide Steel  
Shank Size 3/32"  
Sold in packs of 6

mm	0.5	0.6	0.7	0.8	0.9	1.0	1.1	1.2	1.3	1.4
Drill #	#005	#006	#007	#008	#009	#010	#011	#012	#013	#014
12+	\$7.55	\$7.55	\$7.55	\$7.55	\$7.55	\$7.55	\$7.55	\$7.55	\$7.55	\$7.55
6+	\$8.19	\$8.19	\$8.19	\$8.19	\$8.19	\$8.19	\$8.19	\$8.19	\$8.19	\$8.19
1+	\$9.10	\$9.10	\$9.10	\$9.10	\$9.10	\$9.10	\$9.10	\$9.10	\$9.10	\$9.10

mm	1.5	1.6	1.7	1.8	2.0	2.1	2.2	2.3
Drill #	#015	#016	#017	#018	#020	#021	#022	#023
12+	\$38.32	\$38.32	\$38.32	\$38.32	\$38.32	\$38.32	\$38.32	\$38.32
6+	\$39.98	\$39.98	\$39.98	\$39.98	\$39.98	\$39.98	\$39.98	\$39.98
1+	\$41.65	\$41.65	\$41.65	\$41.65	\$41.65	\$41.65	\$41.65	\$41.65



**Kit Order # 28-10003**

Description	Size	12+	6+	1+
12-Piece Bur Kit (1 each)	.50mm-1.6mm	\$16.58	\$17.55	\$19.50

**PANTHER® DIAMOND TWIST DRILL FIG. #77D**



**Order # 28-10002**

Material Tungsten Carbide Steel  
Shank Size 3/32"  
Sold in packs of 6

mm	0.8	0.9	1.2
Drill #	#008	#009	#012
12+	\$46.46	\$46.46	\$46.46
6+	\$48.48	\$48.48	\$48.48
1+	\$50.50	\$50.50	\$50.50



**BUSCH® TUNGSTEN VANADIUM STEEL DRILLS**

Tungsten vanadium steel makes drills both tougher and harder. Only a small amount of vanadium is needed to increase the hardness, strength, and high temperature stability of steel.



**Order # 28-10005**

Material Tungsten Vanadium Steel  
Shank Size 3/32"  
Sold in packs of 6

mm	0.5	0.6	0.7	0.8	0.9	1.0	1.1
12+	\$15.04	\$15.04	\$15.04	\$15.04	\$15.04	\$15.04	\$15.04
6+	\$15.70	\$15.70	\$15.70	\$15.70	\$15.70	\$15.70	\$15.70
1+	\$16.35	\$16.35	\$16.35	\$16.35	\$16.35	\$16.35	\$16.35

mm	1.2	1.4	1.5	1.6	1.8	1.9
12+	\$15.04	\$15.04	\$15.04	\$15.04	\$15.04	\$15.04
6+	\$15.70	\$15.70	\$15.70	\$15.70	\$15.70	\$15.70
1+	\$16.35	\$16.35	\$16.35	\$16.35	\$16.35	\$16.35



**Kit Order # 28-5860**

Description	Size	12+	6+	1+
12-Piece Bur Kit (1 each)	1.3mm-4.0mm	\$26.10	\$27.63	\$30.70

**Order # 28-1000**

Material High Speed Steel  
Shank Size 3/32"  
Sold Each

mm	0.7	0.8	0.9	1.0	1.1	1.2	1.3	1.4
12+	\$5.10	\$5.10	\$5.10	\$5.10	\$5.10	\$5.10	\$5.10	\$5.10
6+	\$5.40	\$5.40	\$5.40	\$5.40	\$5.40	\$5.40	\$5.40	\$5.40
1+	\$6.00	\$6.00	\$6.00	\$6.00	\$6.00	\$6.00	\$6.00	\$6.00

mm	1.5	1.6	1.7	1.8	1.9	2.0	2.1
12+	\$5.10	\$5.10	\$5.10	\$5.10	\$5.10	\$5.10	\$5.10
6+	\$5.40	\$5.40	\$5.40	\$5.40	\$5.40	\$5.40	\$5.40
1+	\$6.00	\$6.00	\$6.00	\$6.00	\$6.00	\$6.00	\$6.00

**Kit Order # 28-1000**

Item	Description	Size	12+	6+	1+
A	6-Piece Bur Kit (1 each)	1.0, 1.3, 1.4, 1.6, 1.8, 2.1	\$18.16	\$20.43	\$22.70

**PRIMO® DIAMOND-COATED TWIST DRILLS**

Use to drill stones, glass, pearls, and ceramics. Diamond is evenly plated on high-speed steel blanks for maximum life. Medium/Fine grit. Always use a small amount of water or coolant when drilling for longer drill life and faster cutting. Wear safety glasses.



**Order # 28-10006**

Material Stainless Steel  
Shank Size 3/32"  
Sold Each

mm	1.5	2.0	2.5	3.0	4.0	5.0
12+	\$5.75	\$5.75	\$5.19	\$5.19	\$5.75	\$5.75
6+	\$6.00	\$5.63	\$5.63	\$6.00	\$6.00	\$6.00
1+	\$6.25	\$6.25	\$6.25	\$6.25	\$6.25	\$6.25

Technical Note: Always use a lubricant or water when working with diamond-coated instruments

**DIAMOND-COATED CORE DRILLS**

Use to cut holes in ceramics, tile, and glass without chipping or cracking. Shanks are three millimeters, feature medium-fine grit, and are made of stainless steel with electroplated diamond particles.





**PIN VISE WITH SQUARE CHUCK**

Use to hold small drills, wire, taps, screwdriver blades, and more.

Order # 58-24500

Item	Capacity	Length	12+	6+	1+
A	0-2mm	3"	\$6.55	\$6.93	\$7.70
B	0-2mm	4¼"	\$7.74	\$8.19	\$9.10
C	0-2mm	4¾"	\$7.95	\$8.42	\$9.35
D	0-2mm	5"	\$8.46	\$8.96	\$9.95



**DOUBLE-ENDED PIN VISE**

Each end contains reversible, steel collets. Rolling prevented by hexagonal head. Hollow handle and heads are made of brass.

Order #	Capacity	Length	12+	6+	1+
58-2400	0 – 3.2mm	4"	\$4.97	\$5.27	\$5.85



**SWIVEL PIN VISE**

Use for drilling or tapping. Contains two double-ended chucks.

Order #	Capacity	Length	12+	6+	1+
58-2200	0 – 3.3mm	4"	\$4.38	\$4.64	\$5.15



**WING-NUT HAND VISE**

Use to hold small drills, wire, taps, screwdriver blades, and more. Hollow handles allow long wire to pass through. Jaws have spring action and are serrated and grooved. Open and close with large wing nut.

Order #	Length	Width	Jaw Opening	12+	6+	1+
58-1400	4½"	¾"	¼"	\$24.82	\$26.28	\$29.20



**GRS® HAND CHUCK**

This precision hand chuck holds a variety of tools including many gravers. Its two-jaw chuck is made of hardened and ground steel with a v-notch in each jaw for superior grip. Extremely versatile, comfortable shape and size.

Order #	Opening	Length	1+
26-4039	1.5mm	2"	\$41.20



**SWIVEL TOOL HANDLE**

Use for drilling, reaming, and other applications. The barrel turns by twisting the knurled collar. Holds earring while setting.

Order #	Opening	Length	12+	6+	1+
37-9000	1.5mm	4"	\$13.18	\$13.95	\$15.50



**ADAPTER CHUCKS**

Allows small drills to be adapted to larger chucks or flex shaft handpieces.

Item	Order #	Description	Capacity	Collet Size	12+	6+	1+
E	28-2115	1 collet	1.15mm	⅜"	\$6.42	\$6.80	\$7.55
	28-2116	2 collets	2.5mm	⅜"	\$10.16	\$10.76	\$11.95

**AUTOMATIC CENTER PUNCH**

Punches, marks, and scribes. Lightweight aluminum body with replaceable steel point for long wear and adjusts for light or heavy markings. Pencil-slim design features a pocket clip.

Order #	Description	Length	12+	6+	1+
47-8014	Center Punch	7"	\$15.05	\$15.93	\$17.70



**MICRO CHUCK**

Use with #70 and #80 drills.

Order #	Opening	Shank Size	12+	6+	1+
28-2118	1.5mm	⅜"	\$4.51	\$4.70	\$4.90



**COMBINATION CENTERING AND RIVETING PUNCH**

Allows automatic stroke and adjustable for light, medium, or heavy impressions. Fitted with centering point.

Order #	Description	12+	6+	1+
47-8002	Centering and Riveting Punch	\$22.14	\$23.45	\$26.05



**PIN SLIDE**

Easy to operate with one hand due to knurled ring which slides forward to close steel jaws. Hollow handle.

Order #	Capacity	Length	12+	6+	1+
58-2410	0 – 1.3mm	4⅞"	\$9.61	\$10.17	\$11.30



**AUTOMATIC MINI CENTERING PUNCH**

Slim design for better visibility. Pushing down on body releases striking mechanism which can be adjusted for light or heavy strokes. Removable centering point can be interchanged with cup-shaped riveting point. Pocket clip included.

Order #	Description	12+	6+	1+
47-8016	Mini Centering Punch	\$16.96	\$17.96	\$19.95



**412 SLICK LUBE**

The most advanced coolant on the market today. The 100% synthetic polymer coolant is a unique blend of wetting agents, lubricants, and rust inhibitors. Excellent for drilling and cutting, it contains no nitrosamines, phenols, nitrates, sulphur, chlorine, phosphates, or oil. It controls dermatitis with the addition of skin conditioners. Keeps machinery and work cleaner and has excellent rust prevention properties. Concentrate mixes 10:1.

Order #	Container Volume	12+	6+	1+
26-1003	16 oz bottle	\$10.63	\$11.25	\$12.50







Engraving

# ENGRAVING



## EASY JEWEL IV LASER MARKING SYSTEM

This is jewelry marking made easy. Typical jewelry marking tasks are handled effortlessly with perfect results. Thanks to numerous innovations, even inside marking of wide or special shape rings is now easily achieved. The sophisticated marking software automatically makes geometrical corrections due to the non-perpendicular approach to the marking area. Large markings can be executed with the help of an auto-tilting function. Within minutes, the system is retooled for marking flat parts. Based on advanced completely air cooling technology. As an all-in-one laser marking solution with compact design the system is portable. The 100V-240V connection ensures quick and easy initial operation without requiring any additional device like for example an external cooling. A special safety feature is the enclosed marking area (laser class 1). Wearing laser safety goggles is thus not necessary a fact which enhances operator convenience.



Easy Jewel Pins

176 lbs

- Bench-top laser marking system for jewelry manufacturing
- Advanced laser technology
- Engrave inside and outside rings
- Engrave flat, irregular, and unique shapes

Order #	Description	1+
14-0146	Easy Jewel IV 50F Fiber Laser Engraver	\$98,700.00
14-0146	Easy Jewel IV 30F Fiber Laser Engraver	\$81,900.00
14-0146	Easy Jewel IV 20F Fiber Laser Engraver	\$71,900.00
14-0200	Easy Jewel IV Laser Marking System	\$65,000.00
14-0146	Easy Jewel IV 10E Laser Engraver	\$61,900.00

## EASY JEWEL IV LASER ENGRAVER

Advanced laser technology and marking software enable new applications and bring laser marketing and engraving to the highest standards. This EasyJewel with Enhanced Mode has been especially designed for circumferential seamless design and large components requiring uniform surfaces.

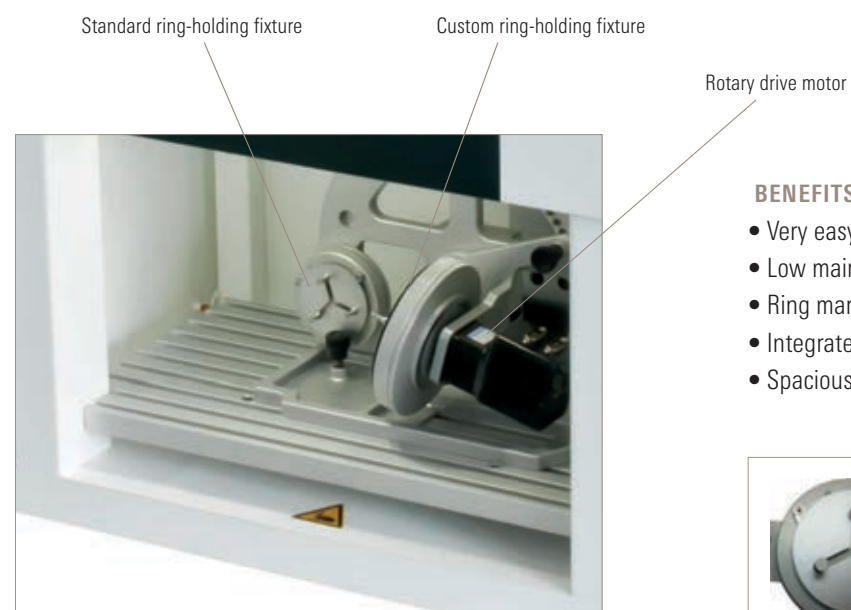

Standard ring-holding fixture

Custom ring-holding fixture

Rotary drive motor

## BENEFITS

- Very easy operation using graphical interface
- Low maintenance and service costs
- Ring marking module-patent pending
- Integrated air cooling
- Spacious working chamber

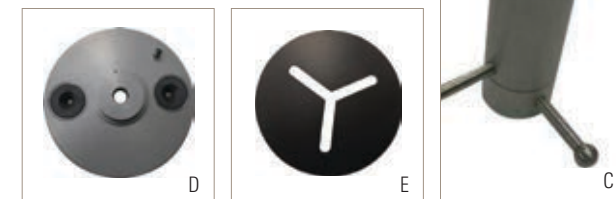

## EASY JEWEL IV ACCESSORIES

Item	Order #	Description	1+
A	14-0148	Chuck, Symmetric Ring (standard)	\$2,177.60
B	14-0148	Chuck, Symmetric Ring (custom)	\$1,125.15
C	14-0149	Centering Fixture	\$2,043.25
D	14-0147	Support Flange M/MTR	\$450.50
E	14-0153	Rotary Cam Centering Plate	\$379.80
F	14-0150	Flapper for Centering Tool	\$83.85
G	14-0155	Replacement Flat Marking Angle Plate (2 required)	\$115.15
H	14-0154	Replacement Spring for Chuck, Symmetric	\$9.10

### Order # 14-01470

Item	Description	1+
J	Pin, 13.9mm Conical (3 each required)	\$67.70
	Pin, 8.9mm Conical (3 each required)	\$25.25
	Pin, 15.0mm Cylindrical (3 each required)	\$29.30
	Pin, 8.0mm Cylindrical (3 each required)	\$29.30
	Pin, 11.4mm Conical (3 each required)	\$67.70



**BEST BUILT CUTTING MILLING AND ENGRAVING SYSTEM**

BB70 is a multifunctional engraving and cutting machine that engraves on pendants, the inside of a ring or bangle, and the outside of a ring or bangle. The BB70 will create beautiful and lasting letters, as well as patterns, quickly and easily. It can also do 2D cutting on gold, silver, brass, wax, acrylic, and wood. If you have the design capability, the BB70 can create nameplate and monogram jewelry. Advanced users can even do 3D carving in wax. The BB70 includes MagicArt Software.

Item	Order #	W×H×D	1+
A	26-3928	15.5"×14.7"×15.5"	\$8,495.00

**ENDMILL TIP**

Use this rotary cutting tool with the Best Built UT- 75/BB70 engraver.

Order # 26-3925

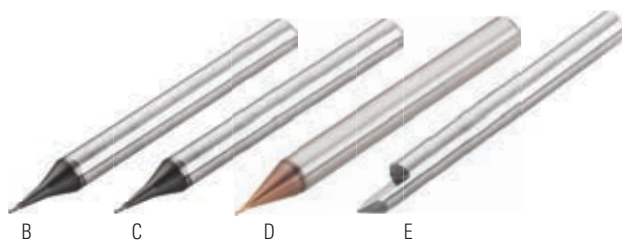

Item	Description	12+	6+	1+
B	Endmill Tip .60mm	\$34.30	\$36.32	\$40.35
C	V Cutter Tip	\$34.30	\$36.32	\$40.35
D	Endmill Tip .40mm	—	—	\$40.35
E	Endmill Tip .50mm	\$34.30	\$36.32	\$40.35

**BEST BUILT COMBO ENGRAVER**

BB 50M is a versatile engraver that engraves on pendants, the inside and outside of rings and bangles, pens, watches and more! It can also create designs and patterns, and even produce logos and images. The BB50 is quiet and compact and the MagicArt engraving software is included.

- MagicArt is very intuitive, easy to learn and use.
- Engrave on all metals such as gold, silver, copper and stainless steel.
- Engrave on the inside and outside of rings and bangles.
- Bangle maximum is 83.5mm.
- Engrave flat objects up to 4" x 4.5"
- Large LCD screen displays status and guides machine use.
- MagicArt software is easy to learn and use.
- Dimensions: 15.5"W x 14.75"H x 15.5"D / 68lbs
- Power: 21W Dual Voltage



Item	Order #	W×H×D	1+
F	26-3926	15.5"×14.75"×15.5"	\$5,995.00

**RING FINGERS/SET OF 3**

Ring Holding Chuck Fingers UT Ring, UT 50 and UT 75

Order # 26-3920

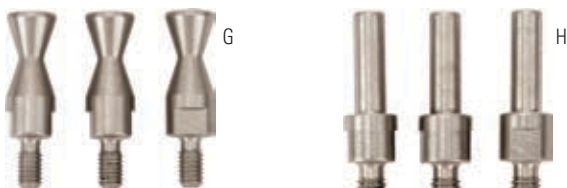

Item	Description	1+
G	Large Curved Ring Fingers (Set of 3)	\$35.35
H	Flat Ring Fingers (Set of 3)	\$35.35

**FLAT ENGRAVING MACHINE**

- Includes type
- Adjustable type slide accommodates both small 1¼" and large 2¾" type.
- Font type: Block letters with numbers
- Punctuation characters
- Spacers
- 15 different pantograph ratios from 2½: 1 to 6: 1.
- Height adjustment for objects up to 2½".
- Quick slide female vise accommodates jewelry, discs up to 4" diameter, or 3½" wide rectangular objects.
- Overall size: 11"H x 14"W x 14½"D.
- Diamond stylus for engraving.
- Vise rotates full 360 degrees

Item	Order #	W×H×D	1+
A	26-3770	14"×11"×14½"	\$600.00

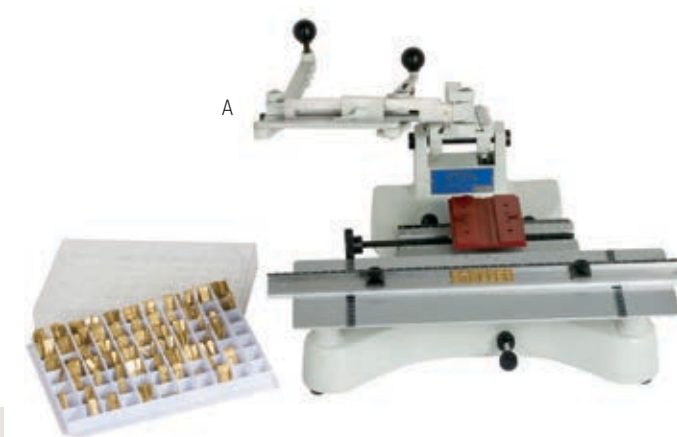

**PRESIDIUM® INSIDE-RING ENGRAVER**

The Presidium® Inside-Ring Engraver is manufactured to the highest standards. The machine is compact, user friendly and comes with a diamond engraving tip, a circular dial template, complete set of instructions, dust cover, and five brass sample rings. Features include easy template installation, wide ring holding capacity, adjustable letter spacing, and the template produces letters with heights of 9mm and 4mm.

Item	Order #	Description	1+
B	26-3850	Inside-Ring Engraver	\$525.00
C	26-4164	Self-Centering Jaw	\$12.00



**GROBET USA® INSIDE-RING ENGRAVER**

This engraving machine is manufactured to the highest standard. It is compact and user-friendly. Features easy type installation, one single dial produces letters with heights of 1mm and 2mm, wide ring-holding capacity of ring sizes from 19mm to 30mm, adjustable letter spacing. Includes a type dial, diamond tip, and five brass sample rings. Block font dial.

Item	Order #	Description	W×L×H	1+
D	26-3780	Grobet Ring Engraver	9"×7"×19½"	\$525.00
E	26-3781	Diamond Stylus Tip		\$48.50

**PRESIDIUM DIAL TEMPLATE SCRIPT**

All engraving dials measure five inches in diameter with ½" center hole.

Item	Order #	Description	1+
F	26-3853	Modern Block Font Large/Small Upper Case	\$125.00
	26-3852	Dial Template Script	\$125.00







**GRS® GRAVERMACH® AT**

GraverMach AT is wonderfully familiar to anyone who uses its predecessors, including the GraverMate, GraverMax® SC, or GraverMach®. But the expanded capability of precise, selectable hand control puts this power tool in a class by itself. The hand control technology is based on the GRS Airtact. This advanced, patent-pending air logic system provides hand control power without adding moving parts to the handpiece itself. The result is a rugged and intuitive way to control handpiece power by hand. When foot control is preferred, it is only two seconds away. This one simple selector knob instantly gives you greater control, choice, and refinement in your work. The ability to instantly change from hand to foot control whenever you want means new creative freedom and reduced stress.

Order #	Description	W x L x H	1+
26-4009	GraverMach AT	6"×13"×8¼"	\$1,898.00



**GRS® GRAVERMAX® G8**

GraverMax® G8 is based on the original GraverMach. This engraving system gives each handpiece excellent range of power with perfect control throughout an expanded range of impact speeds. The GraverMax G8 features 400 to 8,000 strokes per minute, a throttle bias adjustment valve for tailoring throttle response to your work, and a dual-stage precision air regulator. Advanced ergonomics include front air pressure adjustment, Quick Change air couplings, rear mount throttle connection, and an advanced valve pulse unit that operates with virtually no noise or vibration. The GraverMax G8 has connections for two impact handpieces plus an auxiliary air connection for the air tools, including the GRS Ultra 850 rotary handpiece. Handpieces sold separately.

Order #	Description	WxLxH	1+
26-4011	GraverMax G8	5¼"×12"×8¼"	\$1,350.00



**GRS® GRAVERSMITH®**

This new power tool offers basic work capability and pneumatic impact power for stone setting and engraving at less cost than the fully-featured machines. Like all GRS® power tools, the GraverSmith reduces worker fatigue, increases production, and improves quality. A choice of handpieces allow the GraverSmith to fit a wide range of applications and user preferences.

**Includes –**

- Variable impact rate-400 to 8,000 per minute
- Heavy duty foot control
- Built-in air regulator with integral pressure gauge
- One handpiece outlet (handpiece sold separately)
- Remote filter
- Carry handle and built-in tool storage

Order #	Description	WxLxH	1+
26-4013	Graversmith	5¾"×10"×5¾"	\$890.00

Standard systems require oil-free compressed air to operate a standard handpiece. Get the GraverMach AT for integrated Airtact control featuring both and and foot operation. Hand pieces are sold separately.



**A. Monarch** – Monarch is the finest impact handpiece for confident execution of ultra-fine engraving including bulino and banknote styles. Monarch features heat-treated stainless steel construction, an elegant graverstyle handle, and adjustable side hose connection. Includes six quick-change holders. 2.4 inches (61mm) long, and weighs 7.4 ounces.

**B. Magnum** – No other impact handpiece can equal the Magnum's range of power, from heavy to very fine. Its compact size is misleading, as the Magnum exceeds the power of previous models that are twice the length. It also has fine control with shading capability significantly better than any handpiece with this much top-end power.

Item	Order #	Description	1+
A	26-4038	#921 Quick-Change Monarch	\$299.00
B	34-2224	Magnum Airtact Stainless Steel	\$399.00

**GRS® MAGNUM HANDPIECE**

No other impact handpiece can equal the Magnum's range of power, from heavy to very fine. Its compact size is misleading, as the Magnum exceeds the power of previous models that are twice the length. It also has fine control with shading capability significantly better than any handpiece with this much top-end power.

Item	Order #	Description	1+
C	34-2224	GRS Magnum Handpiece	\$418.00

**QUICK-CHANGE 901 HANDPIECE SET**

The comfortable compact shape has an adjustable side hose connection. 901 fits most engraving and stone setting needs including microscopic engraving, deep relief work, and bead raising/hammer setting. Made from fully heat-treated stainless steel. Package includes #901 quick-change handpiece, quick-change hand handle, and quick-change holders.

Item	Order #	Description	1+
D	26-4037	#910 Handpiece Kit	\$349.00

**GRS® MONARCH**

Monarch is the finest impact handpiece for confident execution of ultra-fine engraving including bulino and banknote styles. Monarch features heat-treated stainless steel construction, an elegant graverstyle handle, and adjustable side hose connection. Includes six quick-change holders. 2.4 inches (61mm) long,

Item	Order #	Description	1+
E	26-4038	#921 Quick-Change Monarch	\$299.00

**GRS® QUICK-CHANGE GRAVER ACCESSORIES**

Gravers and/or tools mount into these interchangeable quick-change holders, which in turn fit all GRS quick-change handpieces and GRS quick-change sharpening fixtures. This allows tools to be changed in three seconds without a wrench. Holders accept square tools up to 2.5mm and round tools to 3.3mm. Comes with three quick-change tool holders.

Item	Order #	Description	Per Unit	1+
F	34-2234	Extra-Long	Pack of 10	\$115.90
	34-2233	Extra-Long	Pack of 3	\$35.15

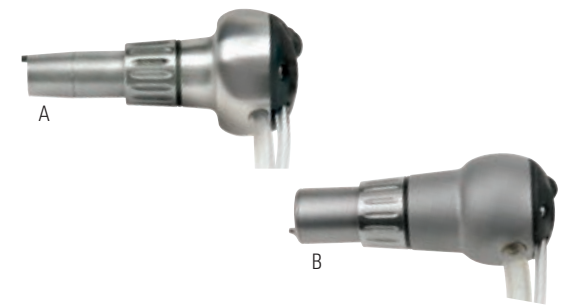

Airtact handpieces require a GraverMach AT System







**SUPER SILENT AIR COMPRESSOR**

These compressors have been engineered and built with the latest technology to provide high-quality clean air for the jewelry, dental, and medical markets. The oil-free dual piston pump system allows the air compressor to work more efficiently creating less noise and less wear for a longer pump life.

- 6-gallon capacity
- 600 watts
- Airflow: 118 liters per minute
- Maximum pressure: 8 bar
- Noise: 52 decibels
- Oil-less operation, maintenance free
- Dimensions: 16"x16"x21"
- 110 Volts

Order #	Capacity	WxLxH	1+
14-4990	6 gal	16"x16"x21"	\$635.00



**CALIFORNIA AIR 4610AC QUIET AIR COMPRESSOR**

The California Air tools 4610AC Ultra Quiet and Oil-Free Air Compressor is ideal for anyone working inside where noise is a major issue. Designed to be one of the quietest air compressors in the industry. It only generates 60 decibels of sound. The New SP Series of ultra quiet air compressor motors have been designed to increase duty cycle and allow for longer continuous run times. The powerful 1.0 HP motor operates at 1680 RPM creating less noise and less wear. The oil-free dual piston pump system is engineered for high performance and durability. The oil-free pump allows for use in a variety of temperatures and uneven terrains. Includes hook-up kit, which contains 50 feet of air tubing and brass fitting.

Order #	WxLxH	1+
14-4997	16.7"x19.1"x19.7"	\$325.00



**SILENTAIRE AIR COMPRESSOR**

The Silentaire air compressor is virtually noiseless and is totally automatic. Unit includes a tank, line pressure gauge, line pressure regulator, moisture trap/filter/gauge, safety valve, air intake filter, and a carrying handle. The SIL-AIR models feature a heavy duty 1/2 hp pump for reliability and durability.

Item	Order #	Description	1+
A	14-4999	6-gallon Compressor (1/2 hp) (40 decibel)	\$1,149.90
	14-5000	4-gallon Compressor (1/2 hp) (40 decibel)	\$1,065.90

**MAINTENANCE PARTS**

B	14-4492	Air Intake Filter	\$19.70
C	14-4493	Filter Element (Pack of 4)	\$13.75
D	14-4494	Filter Regulator WI	\$84.60
E	14-4495	Pressure Gauge 1/8" - Rear	\$26.30
F	14-4496	Filter Element WI	\$26.30
G	14-4497	Filter Kit N Coalescent	\$47.70
H	14-5002	24 oz Compressor Oil	\$23.05
J	14-4498	Blowgun with Coil Hose	\$42.35
K	14-5004	Air Filter/Oil Removal Kit	\$107.05
L	14-5005	Quick Disconnect Kit	\$32.10



59 lbs



**LEICA® BENCH MICROSCOPE**

Ergonomically designed workstations have been proven to increase performance and the quality of work results. Leica Microscope Systems has many years of experience in ergonomics. This is evident in the Leica A60. The 38-degree viewing angle is close to a person's natural head posture. The zoom and focus knobs could not be more accessible. The rheostat of the focus drive can be adjusted to the preferences of a specific user. The operating elements of the ring illuminator are also intuitive and easily accessible by left and right-handed users. The A60 has a large overview with a 46mm object field with approximately 100% greater depth of field and the working distance is 122mm.

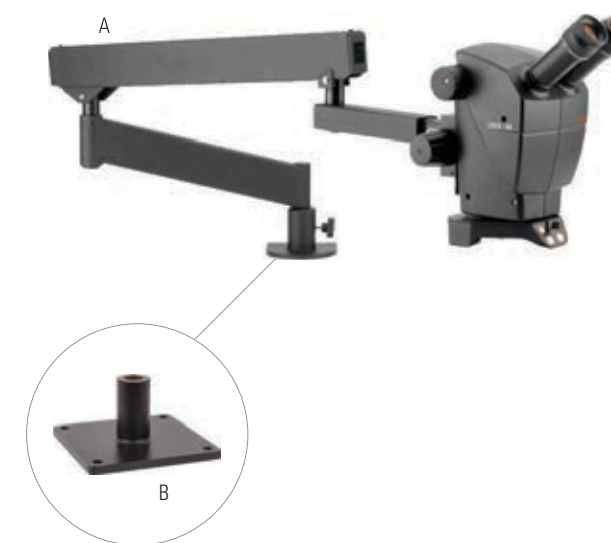

Item	Order #	Description	1+
A	29-4758	Microscope with Flex Arm Stand	\$2,137.25
B	29-4758	Horizontal Surface Mount	\$173.75

**ACROBAT® VERSA AND LEICA® A60**

Trusted by hand engravers and jewelers for years, the GRS Acrobat stand has been redesigned with a sleek form specifically for the high-powered Leica A60 microscope. The new Acrobat Versa features a rigid frame that makes positioning easy, a magnetic document holder, and ergonomic handles for the best optical experience possible. The complete package includes the Acrobat Versa stand, Leica A60 microscope, Optia® LED light, and control mounting base, post, and primary document holder. Secondary document holder and camera mount sold separately.



Item	Order #	Description	12+	6+	1+
C	26-5101	Acrobat® Versa & Leica A60 Complete Package	-	-	\$2,295.00
	26-5100	Adapter Kit	\$162.61	\$169.68	\$176.75
	26-5100	Acrobat® Versa Stand	-	-	\$542.00
D	26-5600	Camera Mount For Leica A60	\$181.19	\$189.07	\$196.95
E	26-5500	Dust Cover	-	-	\$15.15
F	26-5200	Double Document Holder Kit	\$56.72	\$59.18	\$61.65
G	26-5300	0.63X Leica Objective Lens	\$153.32	\$159.98	\$166.65
	26-5300	0.50X Leica Objective Lens	\$153.32	\$159.98	\$166.65
	26-5300	A60 Objective Lens Adapter	\$69.69	\$72.72	\$75.75
	26-5300	0.75X Leica Objective Lens	\$153.32	\$159.98	\$166.65





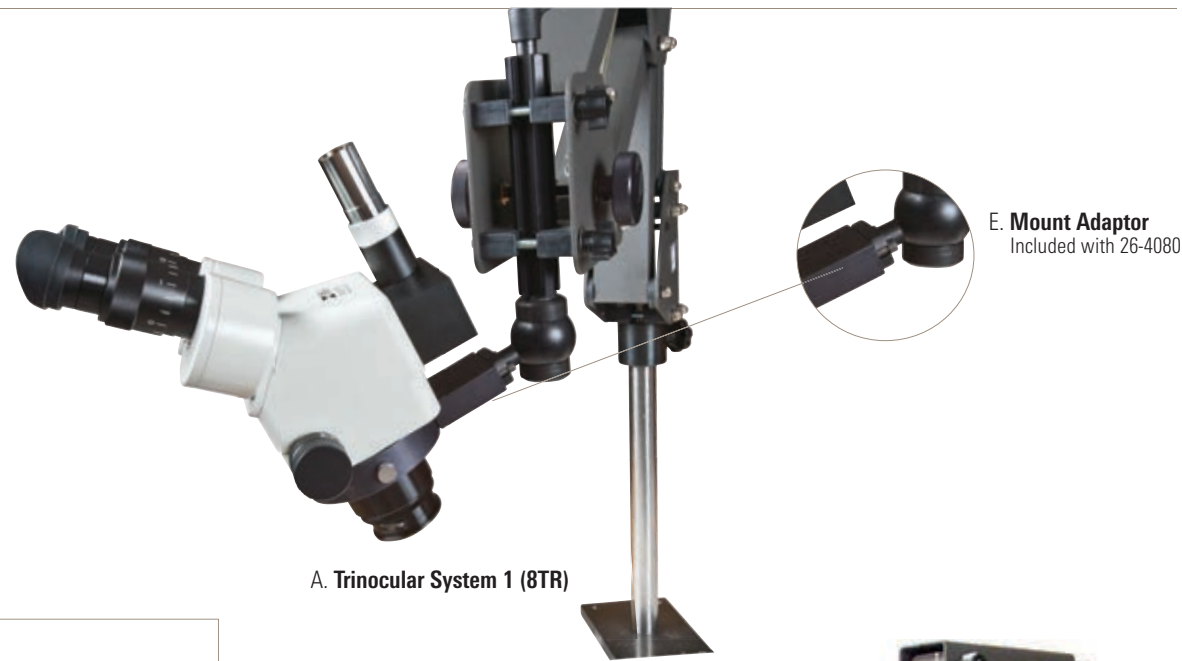

A. Trinocular System 1 (8TR)

E. Mount Adaptor  
Included with 26-4080



B. Binocular System 2 (EMZ-5)



**MEIJI® MICROSCOPE BENCH SYSTEMS**

The Meiji® microscope is designed for working while viewing. Magnified up to 22.5X, you can clearly see the finest details for both stone setting and engraving. With this system, you can work hour after hour without eye strain. This microscope will help you finish your jobs with precision every time.

Item	Order #	Description	Focal Working Distance (with lens)	1+
A	26-4080	Trinocular System 1 (8TR)		\$2,495.95
B	26-4073	Binocular System 2 (EMZ-5)	93 to 150 mm	\$2,075.00
C	26-4082	10X (pair)		\$161.60
D	26-4083	20X (pair)		\$161.60
E	26-4089	Mount Adaptor (included with #26-4080)		\$75.00
F	26-4086	EMT-2 Adapter (required for lens)		\$35.35
G	26-4098	EMZ-5 Auxiliary Lens	150 mm	\$141.40
G	26-4098	EMZ-8TR Auxiliary Lens 0.5mm	174 mm	\$141.40
G	26-4098	EMT-2 Auxiliary Lens	150 mm	\$141.40
H	26-4196	Ring Light		\$174.00
	26-4079	EMZ-5 (body only)	93 mm	\$1,260.00
	26-4081	EMZ-8TR (body only)	104 mm	\$1,630.00
	26-4094	Acrobat Stand (Only)		\$564.00

RinGenie™ devices help you work smart and fast, boosting productivity and accuracy in milling, drilling, channel cutting, engraving, inlaying, and more. Particularly popular for jewelers with a need for speed and precision in engraving and layout work, the RinGenie and its suite of adapters offer unprecedented flexibility. Made in America by SDL Precision, the RinGenie is a revolutionary device that is destined to be a classic tool for generations of jewelers to come.

**RINGENIE™**

The RinGenie was created for designers and stone setters. The RinGenie enhances the precision of setting and engraving rings. With the RinGenie, you can work with wax molds, blanks, or any style of ring. You can work at ease knowing that the RinGenie is securely holding your ring while you're working. With the different angle options you get a complete view and range working with the ring.

**A. Ringenie™ The Complete Kit**

- Body, Drill/Mill/Layout Assembly
- Scriber Assembly
- 3/32 Diameter Hardened Drill bushing
- Alignment Plate
- 2 Tightening Rods
- Side Pointer
- Drag Adjustment Screw
- 8 Plastic Collets (sizes are: 5 6 7 8 9 10 11 12)
- 16 Aluminum Collets (sizes are: 5 5.5 6 6.5 7 7.5 8 8.5 9 9.5 10 10.5 11 11.5 12 12.5)
- Custom Fitted Wood Case



Find added video content on [Stuller.com/VideoCenter](http://Stuller.com/VideoCenter).

Item	Order #	Description	1+
A	26-1800	RinGenie™ The Complete Kit	\$695.00
B	26-1801	RinGenie™ Bench Mate Adapter	\$75.70
C	26-1802	RinGenie™ Side Helper	\$91.95
D	26-1803	RinGenie™ 1 Degree Adapter.	\$252.50
E	26-1804	RinGenie™ Side Helper Kit	\$141.40
F	26-1805	RinGenie™ Versatile Ring Holder	\$201.00
G	26-1806	RinGenie™ Vise	\$681.75
H	26-1807	RinGenie™ Universal Adapter Holder Set	\$146.45
J	26-1808	RinGenie™ Vise Adapter	\$176.75
K	26-1809	RinGenie™ Angle Adapter Kit	\$227.25
L	26-1810	RinGenie™ 5" Positional Ball Vise	\$782.75
M	26-1811	RinGenie™ Positional Rotary Table	\$732.25
	26-1812	RinGenie™ Versatile Ring Holder	\$126.25
	26-1813	RinGenie™ Universal Adapter Holder Only	\$70.00

All items are priced at jeweler's cost, are sold each, unless otherwise noted, and are subject to change without notice. Visit [Stuller.com](http://Stuller.com) for our complete product selections, current pricing, and quantity price breaks. | 247



**GRS® MICROBLOCK BALL VISE**

A. Use for engraving, stone setting, and other precision work. The Microblock's stainless steel low-profile body, stainless steel jaws, and compact design are especially suited for microscope work or other situations where the size of a larger vise is an obstacle.

B. GRS 30-piece attachment set includes leather-faced ring clamps, plus a variety of pins and clamps to fit upper jaws of engraving blocks.

Item	Order #	Description	1+
A	26-4167	Microball	\$282.00
B	26-4130	30 Piece Attachment Kit (only)	\$109.00

Find added video content on [Stuller.com/VideoCenter](http://Stuller.com/VideoCenter).



**GRS® STANDARD BLOCK**

C. Double ball-bearing system for smooth rotation without looseness or wear, the unique GRS rotational break system lets you control the rotational resistance similar to the magna block. Block is made of solid steel. Black jaws and satin chrome finish reduce glare and eye strain. GRS standard block includes upper jaw plates, four pins, and wrench.

- Stainless Steel Body - Block Weight 19 lbs.
- Jaw Height 1½" - Ball Diameter 5"
- Max Opening 3" - Jaw Width 2½"

Item	Order #	Description	1+
C	26-4129	Standard Block (only)	\$486.00



**GRS® POSITIONING VISE**

D. Made for use with microscope work, this unique vise has many magna block similarities and one huge difference: You can reposition its center of rotation by simply pulling a lever. By pulling the release lever, you can slide the upper half into various positions. Under a microscope, your work must stay in the field of view as you rotate the vise. The positioning vise allows you to keep your work within the microscope's field of view. Includes upper jaw plates, five pins, and wrench.

- Specifications
- Block weight 42 lbs
  - Jaw height 1.8"
  - Ball diameter 7.1"
  - Max jaw opening 3½"
  - Jaw width 3"

E. Engraving Block Shelf: Attaches easily to GRS fixed mounting plate to hold your engraving block off the front of your bench. This puts your engraving block at the same working height as your bench pin.

Item	Order #	Description	1+
D	26-4157	Positioning Ball Vise	\$913.00
E	26-4156	Large Block Shelf	\$83.80



**GRS® LOW-PROFILE VISE**

F. The stainless steel low-profile model offers GRS strength and quality in a shorter model. A popular use is under a microscope where six inches (150mm) of space is needed between the microscope and the work. Using other blocks, the eye level of the user can be too high. The low-profile vise has the same jaw size and capacity as the Magna-Block, yet is 1½" shorter. An option for this vise is a heavy-duty turn table base. Includes upper jaw plates, five pins, and wrench.

- Block weight 20¼ lbs (9.19kg)
- Jaw height 1½" (46mm)
- Ball diameter 6½" (147mm)
- Max opening 3½" (89mm)
- Jaw width 3" (76mm)

Item	Order #	Description	1+
F	26-4139	GRS Low Profile Vise	\$658.00



**ADJUSTABLE SWING ARM**

With a six-inch reach in any direction, this exclusive design, developed here at Stuller, gives you an extra hand when setting or engraving. You can set stones under your bench microscope (26-4073 or make your GRS Microblock or mounting bracket (26-4107) even easier to use. Cam locks are built in to hold in any position.

Order #	Description	1+
26-4185	Adjustable Swing Arm (6" reach)	\$149.00



**GRS® TURNTABLE BASE**

Used with the low profile vise, this heavy turntable base lets you reposition the work's center of rotation for working under a microscope. A removable centering post lets you position the turntable in the precise center of your microscope's field of view.

Item	Order #	Description	Diameter	1+
A	26-4162	Turntable Base with Break & Teflon Pad	10"	\$304.00
B	26-4163	Mount Kit		\$20.35



**GRS® MOUNTING PLATES**

C. **Optional Mounting Adapter:** Use to attach the fixed mounting plate to bench tops.

D. **Fixed Mounting Plate:** Used for mounting BenchMate and other GRS® products to your bench.

E. **Adjustable Height Bracket:** Includes an additional fixed mounting plate that can be lowered up to 4" in ½" increments.

F-G. **Engraving Block Shelf:** Attaches easily to GRS fixed mounting plate to hold your engraving block off the front of your bench. This puts your engraving block at the same working height as your bench pin.

Item	Order #	Description	1+
C	26-4106	Mounting Adapter	\$27.55
D	26-4107	Fixed Mounting Plate	\$19.80
E	26-4108	Height Bracket	\$55.10
F	26-4105	Small Block Shelf	\$43.00
G	26-4156	Large Block Shelf	\$83.80



**SUPER PINS**

Heavy-duty plastic and steel pins fit jaw holes in GRS Magna Block and GRS Standard Block.

Item	Order #	Description	Diameter	1+
H	26-4134	4 Pins	¼"	\$10.90





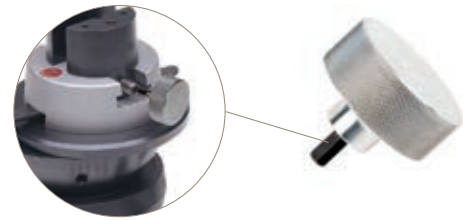

**HEXAGON KEY FOR BALL VISE**

"Hexagon key ball vise features a knurled aluminum low-profile handle design so it can be left inserted in block chuck while working. Fits all GRS vises except the Microblock (Block not included)."

Order #	Description	Outside Diameter	12+	6+	1+
58-2439	Hexagon Key	1/4"	\$14.58	\$15.44	\$17.15



**RING PAD**

When used with engraving blocks, it insulates the workbench surface from heat. Also serves as a rest for the engraving block.

Order #	Description	Diameter	12+	6+	1+
26-3660	Leather	5"	\$56.78	\$60.12	\$66.80



**PIN PLATE**

A. **Single Pin:** For multipurpose and standard vise, this plate will pivot to hold unusual shapes.

B. **Double Pin:** For multipurpose vise, this is a stationary plate with two mounting pins to prevent pivoting.

Item	Order #	Description	12+	6+	1+
A	26-4151	Single Pin Plate	\$23.80	\$25.20	\$28.00
B	26-4152	Double Pin Plate	\$23.80	\$25.20	\$28.00

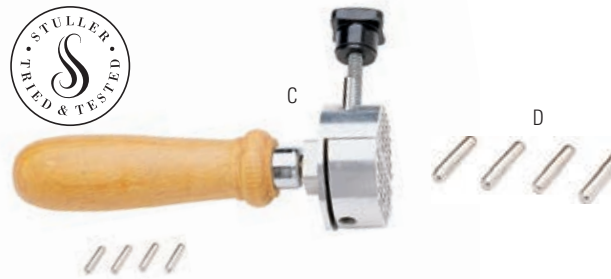

**PEG CLAMP**

Handheld tool that holds small, odd-shaped articles for engraving. Jaws are two inches round, and open and close on twin guides, which are controlled by the threaded thumbscrew. Detachable wooden handle allows head to be mounted in vise. Includes four pegs. Overall length 5 3/4".

Item	Order #	Description	Length	12+	6+	1+
C	26-5000	Peg Clamp	5 3/4"	\$17.43	\$18.45	\$20.50
D	26-5001	Set of 4 Pins		\$2.72	\$2.88	\$3.20



**GRS® RING-CLAMP SET**

Leather-faced attachment for GRS blocks, holds rings solid to set stones, bright cut, engrave, and finish.

Order #	Description	12+	6+	1+
26-4147	Ring Clamp Set	\$22.48	\$23.81	\$26.45



Ring not included.

**GRS® INSIDE-RING ENGRAVING HOLDER**

This handy ring holder securely holds a ring and allows easy access to the inside of the ring for engraving. Designed to be held in the hand or in a bench or ball vise. Made of hardened steel.

Order #	Description	12+	6+	1+
26-4154	Ring Holder	\$59.46	\$62.96	\$69.95



**GRS® ID RING HOLDER**

Take ring fixtures to a new level. The expansion cones assure equal pressure on both sides of the mandrel as it grips the inside diameter of the ring. When using the standard cone, the ring drag can be set to allow smooth rotation of the piece, while setting stones or engraving the ring surface. Includes a set of 10 mandrels and all tooling.

Order #	Description	12+	6+	1+
26-4182	Ring Holder	\$65.45	\$69.30	\$77.00

**ENGRAVING PRACTICE SHEETS**

Use to practice engraving and stone setting. Flat plates come in half-hard brass and copper. Sold in packs of 3.

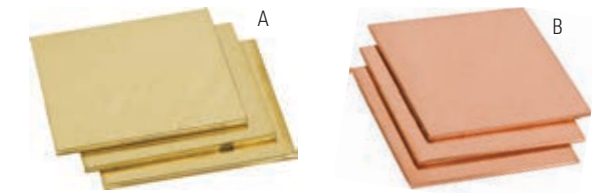

Item	Order #	Description	WxL	12+	6+	1+
A	26-4165	Square Brass	2"x2"	\$15.69	\$16.37	\$17.05
B	26-4166	Square Copper	2"x2"	\$12.83	\$13.39	\$13.95

**BRASS SHEETS**

Use to practice engraving. Sold in packs of 12.



Order #	Description	WxL	12+	6+	1+
36-1556	Brass Sheets	3/16"x2 1/8"	\$24.66	\$25.73	\$26.80

**COPPER RINGS**

Use to practice engraving.



Order #	Description	12+	6+	1+
26-5400	Copper Rings	\$1.79	\$1.87	\$1.95

**SYNTHETIC BEESWAX**

When rubbed on a surface, it leaves a film on which a design can be marked.

Item	Order #	Description	Size	12+	6+	1+
C	26-1000	Beeswax	1 oz tube	\$3.54	\$3.70	\$3.85
D	26-1002	Cake	1 lb cake	\$9.48	\$10.04	\$11.15

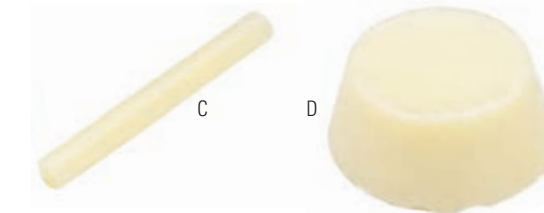

**CHINESE WHITE**

Apply onto a surface when melted, allows an impression to be left by a pencil mark.

Item	Order #	Description	Size	12+	6+	1+
E	26-1600	Small Cake	0.19 oz	\$16.51	\$17.23	\$17.95



**GRS® PITCH BOWL AND PITCH CUP**

Both are filled with a special, meltable material that softens when heated. They allow you to hold small, fragile, irregular, or thin pieces for engraving, setting, and finishing. Both will fit any vise or engraving block.

Item	Order #	Description	WxLxH	12+	6+	1+
F	26-4113	Pitch Bowl	3 1/4"x4 3/4"x1/2"	\$68.72	\$71.71	\$74.70
G	26-4149	Pitch Cup	2" Diameter	\$25.53	\$26.64	\$27.75



**PITCH BOWL SET**

Suitable for holding or supporting jewelry for engraving. The bowl is made of cast iron and rests on a rubber pad. The bowl can be tipped to a comfortable working angle. Includes: pitch, bowl, and rubber pad.

Item	Order #	Description	Size	12+	6+	1+
H	26-4205	Pitch Bowl Set	6 1/4" Diameter	—	—	\$39.75
	26-4215	Pitch	8 oz	\$33.67	\$35.14	\$36.60

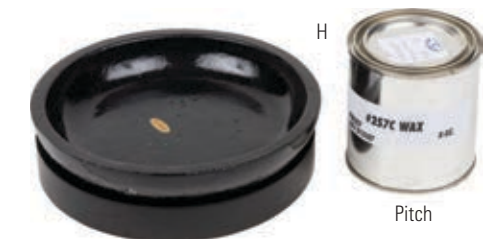

Pitch

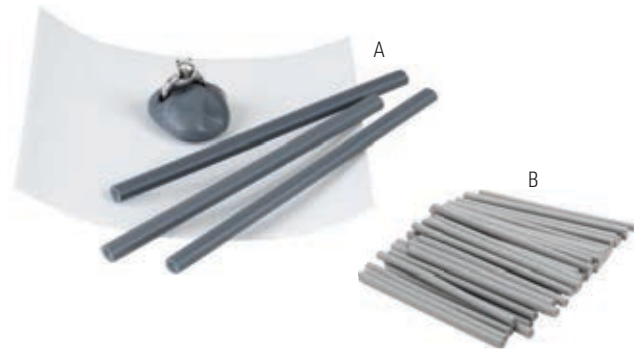

**STARTER KIT**

Kit includes six-inch square PTFE (Teflon pad) and one pound Thermo-Loc® sticks. Thermo-Loc® is a special reusable polymer material that is rigid at room temperature yet becomes softly pliable when heated/warmed. Always place on Thermo-Loc® (Teflon) pad when warming in microwave oven. Ring not included.

Item	Order #	Description	12+	6+	1+
A	26-4168	Starter Kit	\$41.86	\$43.68	\$45.50
B	26-4169	1 lb of Sticks	\$38.32	\$39.98	\$41.65



**ORANGE FLAKE SHELLAC**

When heated, this shellac is used to hold objects for chasing, engraving, or setting.

Order #	Description	Size	12+	6+	1+
12-2270	Flake Shellac	16 oz	\$12.47	\$13.01	\$13.55

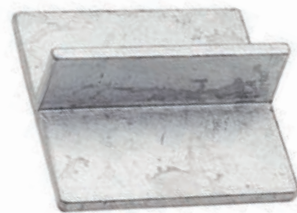

**GRS® SHELLAC PAD**

Insert into the jaws of BenchMate® for setting and engraving.

Order #	Description	12+	6+	1+
26-4112	Shellac Pad	\$11.91	\$12.43	\$12.95



**SHELLAC STICKS**

Use this opaque stick for setting jewels and stones and for temporarily holding objects. Heat to apply.

Item	Order #	Description	Length	12+	6+	1+
C	12-2300	Shellac Stick	7"	\$12.97	\$13.54	\$14.10

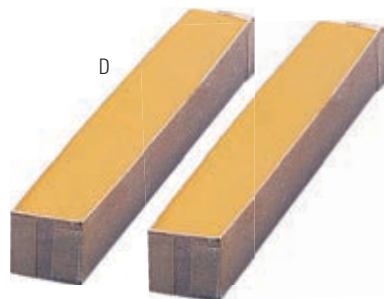

**CHASER'S CEMENT**

Use to attach objects to work holders. Arrives in bar form but melts easily. Can be cleaned with alcohol. Two ½ lb. bars per box.



Item	Order #	Description	Size	12+	6+	1+
D	12-2030	Chaser's Cement	2-½ lb bars	\$36.48	\$38.06	\$39.65



**DIAMOND SETTERS CEMENT**

Securely holds diamonds or other precious stones for polishing operations when melted and applied to a wooden dowel.

Item	Order #	Description	WxLxDepth	12+	6+	1+
E	12-2080	Setters Cement	3"x3"x¼"	\$25.16	\$26.26	\$27.35

**DOUBLE-ENDED STEEL TRACER**

Twisted center allows firm grip. Ends are finely honed. Overall length is 6½".

Item	Order #	Description	Length	12+	6+	1+
A	52-9660	Tracer	6½"	\$8.08	\$8.55	\$9.50



**DIAMOND-TIPPED SCRIBER**

Used to scribe hardest metals, glass, and stones. Hexagonal, aluminum handle prevents rolling.

Item	Order #	Description	Length	12+	6+	1+
B	52-9504	Scriber	5¼"	\$15.56	\$16.47	\$18.30

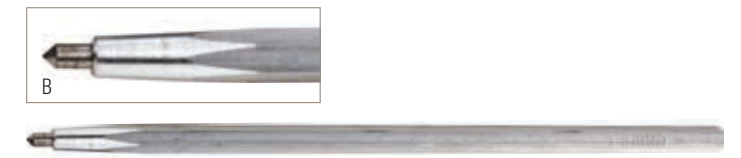

**TUNGSTEN-CARBIDE TIP SCRIBER**

Tungsten-carbide tip scriber marks stainless steel, copper, ceramics, and platinum. Reverse the tungsten-carbide point with the screw chuck when not in use. Tip is replaceable. Measures six inches overall.

Item	Order #	Description	12+	6+	1+
C	52-9505	Tungsten-Carbide Tip Scriber	\$5.87	\$6.21	\$6.90
	52-9506	Replacement Tips	\$2.81	\$2.97	\$3.30



**CARBIDE TIPPED SCRIBER**

Use to scribe hard metals, glass, and stones. Hexagonal, aluminum handle prevents rolling. Slim-line design is comfortable to use.

Item	Order #	Description	Length	12+	6+	1+
D	52-9502	Scriber	5¼"	\$4.17	\$4.41	\$4.90

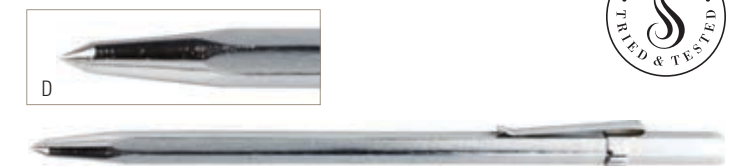

**WALLER SCRIBER**

Use to scribe hard metal, glass, and stone. Reversible ends offer protection while carrying.

Item	Order #	Description	12+	6+	1+
E	52-9500	Scriber	\$5.61	\$5.94	\$6.60
	52-9501	Replacement Tip	\$4.42	\$4.68	\$5.20

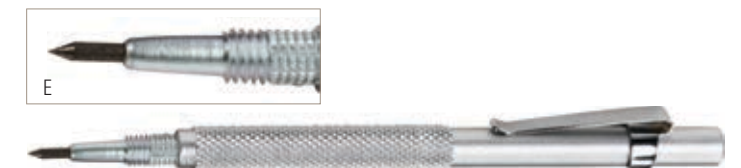





**Dual Angle System Includes** a dual-angle sharpening fixture, power hone, quick wheel change adapter, 260 grit and 600 grit diamond wheels, ceramic lap, 1/2 micron diamond spray, and wheel storage rack.

**Quick-Change System Includes** quick change sharpening fixture, power hone, quick wheel change adapter, 260 grit and 600 grit diamond wheels, ceramic lap, 1/2 micron diamond spray, and wheel storage rack.

Item	Order #	Description	1+
A	26-4161	Dual Angle Fixture System	\$1,195.00
B	26-3999	Quick-Change Fixture System	\$1,104.00



**GRS® BASIC POWER HONE™**

C. GRS Power Hone™ uses diamond wheels to sharpen hardened steels, high speed steels, and carbides. The wheels last for years and stay flat for accuracy. Different grits are available from coarse to mirror polishing. With its heavy steel housing, continuous-duty motor, and double-bearing spindle, the GRS Diamond Power Hone™ is a sharpener you can depend on for years. Includes 600 grit diamond wheel, quick wheel adapter. 115V and 220V models available.

Item	Order #	Description	1+
C	26-4160	Diamond Power Hone (without fixture)	\$561.00



**GRS® QUICK WHEEL CHANGE ADAPTER (FOR ORIGINAL)**

D. Change Power Hone™ wheels in two seconds. This drive plate assembly replaces the standard wheel knob. To change wheels, you just lift them on and off. Quick wheel change adapter is shown with Power Hone™ system. Sharpening wheel and Power Hone not included.

Item	Order #	Description	1+
D	26-4019	Wheel Change Adapter	\$74.00



**GRS® DUAL-ANGLE SHARPENING FIXTURE**

E. The dual-angle sharpening fixture holds a wider variety of tools and adjusts to more angles than the standard fixture. With two degree dials, you can set the elevation angle and the rotation angle of each tool. This fixture is accurate and beautifully made. Its degree dials are large and easy to read. All tool gripping surfaces are hardened steel for long life.

**GRS® QUICK-CHANGE SHARPENING FIXTURE**

F. Just insert your tool into the front of the unit and sharpen. The unit has two-degree dials, plus a unique detente system that makes sharpening fast, easy and accurate. Comes with stand.

**GRS® STANDARD SHARPENING FIXTURE**

G. You'll sharpen accurate tools because the degree dial lets you set the precise angle. Saves time and gives you a better edge for making the cleanest, smoothest cuts ever. Holds tools with or without handles.

Order # 26-40000

Item	Description	1+
E	Dual Angle Sharpening Fixture	\$286.00
F	Quick-Change Sharpening Fixture	\$223.25
G	Standard Sharpening Fixture	\$155.00



**GRS® POWER HONE™ ACCESSORIES**

Item	Order #	Description	OD	Grit	Micron	12+	6+	1+
A	26-4014	Diamond Wheel	5"	260		\$87.55	\$92.70	\$103.00
B	26-4015	Diamond Wheel	5"	600		\$79.90	\$84.60	\$94.00
C	26-4016	Diamond Wheel	5"	1200		\$79.90	\$84.60	\$94.00
D	26-4017	Ceramic Lap	6"			\$178.50	\$189.00	\$210.00
E	26-4018	Wheel Storage Rack				\$18.79	\$19.89	\$22.10
F	26-4043	Diamond Spray (Coarse)			3μ	\$28.11	\$29.33	\$30.55
G	26-4042	Diamond Spray (Medium)			1μ	\$28.11	\$29.33	\$30.55
H	26-4041	Diamond Spray (Fine)			1/2μ	\$28.11	\$29.33	\$30.55
J	26-4040	Diamond Spray (Extra Fine)			1/4μ	\$28.11	\$29.33	\$30.55



**STEVE LINDSAY TEMPLATE KITS**

The Lindsay graver sharpening fixture is a quick way to consistently sharpen a 3/32" square graver point accurately. Using the universal template, the sharpener will grind the patented Uniform-Parallel Point™ in a variety of configurations, as well as produce other points. A huge benefit of this sharpener is that it is repeatable as far as making a particular point that is normally fussy to produce with adjustable angle type sharpeners. Kit contains a Lindsay sharpening fixture and Uniform-Parallel Point template (Image K).

Item	Order #	Description	1+
K	26-3990	Sharpening Fixture without Stones	\$92.55
L	26-3991	Universal Template and 4 Diamond Bench Stones	\$234.00
	26-3992	4 Templates and 4 Diamond Bench Stones	\$305.80

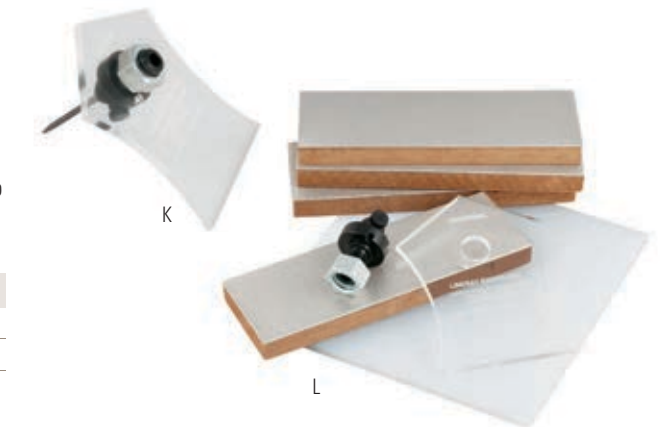

**EASYGRAVER V-POINT SHARPENING FIXTURE**

Many new engravers are challenged with understanding and consistently producing accurate sharpening results. Professionals want to save time during the sharpening process to increase profitable moments spent at the bench. The design of the EasyGraver Sharpening Fixture is based on the standard geometries that we observed in use by hundreds of engraving artists and jewelers throughout the world over many years. Two separate models are available: 120° or 105°, both for creating V-point gravers. For hand engravers and jewelers who currently use other geometries, the time it takes to adjust to these presets is outweighed by the benefits of accuracy and efficiency.

Item	Order #	Description	12+	6+	1+
M	26-3985	V-Point 105°	\$117.30	\$124.20	\$138.00
N	26-3985	V-Point 120°	\$118.49	\$125.46	\$139.40
P	26-4191	Qc Locking Adapter Kit	—	—	\$36.85
	26-3986	Post Assembly	\$29.54	\$31.28	\$34.75

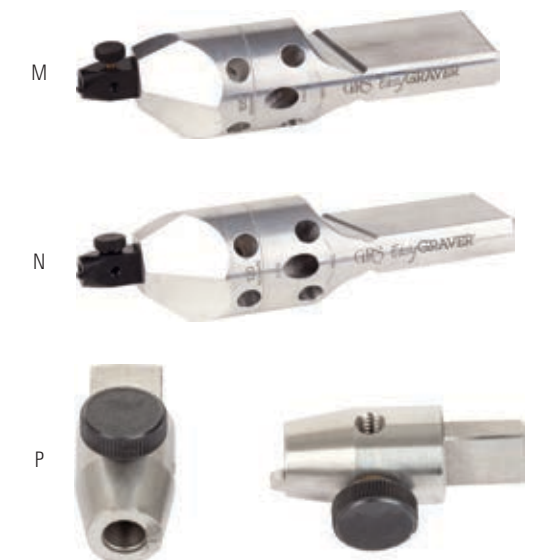



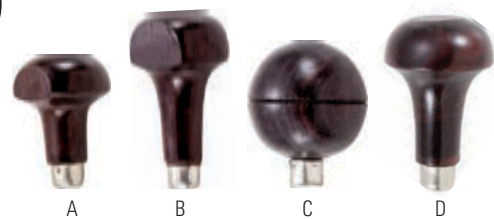

**ROSEWOOD GRAVER HANDLES**

Use to hold gravers securely with reinforcing metal collets.

Order # 37-86000

Item	Description	Width	Length	12+	6+	1+
A	Half-Head	1¼mm	1½"	\$2.51	\$2.66	\$2.95
B	Long Half-Head	1¼mm	2"	\$2.51	\$2.66	\$2.95
C	Round	1¾mm	1¾"	\$2.51	\$2.66	\$2.95
D	Long Mushroom	1¼mm	2"	\$2.51	\$2.66	\$2.95



**GRAVER HANDLES**

Choose from a wide variety of finely finished, hardwood handles. Metal sleeve securely holds graver.

Order # 37-85000

Item	Description	Width	Length	12+	6+	1+
E	Gourd	2½mm	1¼"	\$1.28	\$1.35	\$1.50
F	Half-Head	2mm	1⅓"	\$1.28	\$1.35	\$1.50
G	Half-Head	1¾mm	1⅓"	\$1.28	\$1.35	\$1.50
H	Half-Head	2¼mm	1¼"	\$1.28	\$1.35	\$1.50
J	Mushroom	2mm	1¼"	\$1.28	\$1.35	\$1.50
K	Mushroom	1¾mm	1¼"	\$1.28	\$1.35	\$1.50
L	Mushroom	2¼mm	1¼"	\$1.28	\$1.35	\$1.50
M	Oval	1mm	1¼"	\$1.28	\$1.35	\$1.50
N	Pear	1¾mm	1¾"	\$1.28	\$1.35	\$1.50
P	Round	1¾mm	1½"	\$1.28	\$1.35	\$1.50
Q	Vase	3mm	1½"	\$1.28	\$1.35	\$1.50



**ADJUSTABLE GRAVER HANDLE SET**

Adjust your graver length to exactly what you want by sliding it in and out of the handle, locking it in place. Made of lightweight aluminum, this set features three different color handles.

Item	Order #	Description	Length	1+
R	26-4136	Graver Handle Set (set of 3)	2¾"	\$44.40

**THERMO-LOC® HANDLES**

These handles let you install gravers and similar hand tools without the frustration of drilling. Inside each handle is a core made of Thermo-Loc, a special heat-softenable material. Simply warm the handle or heat the tool tang and insert the tool. At normal temperatures, Thermo-Loc becomes solid to hold the tool securely with a perfect fit. Includes four handles, extra Thermo-Loc, and instructions. The Thermo-Loc core softens between 160°-180°F (70°-80°C).

Item	Order #	Description	12+	6+	1+
S	26-4140	Thermo-Loc Handle Set	\$12.88	\$13.44	\$14.00



**FACETED GEM-SETTING GRAVER SET**

Use for setting diamonds and other stones. Set consists of six carbon steel gravers, six wooden handles, and a step-by-step model plate. Contains gravers point (onglette) #0 and #1; flat #38 and #40; and round #50 and #52.

Item	Order #	Description	12+	6+	1+
T	53-0700	Gem-Setting Outfit Set	\$56.95	\$60.30	\$67.00



**GRS® QUICK-CHANGE GRAVER ACCESSORIES**

Gravers and/or tools mount into these interchangeable quick-change holders, which in turn fit all GRS quick-change handpieces and GRS quick-change sharpening fixtures. This allows tools to be changed in three seconds without a wrench. Holders accept square tools up to 2.5mm and round tools to 3.3mm. Comes with three quick-change tool holders.

Item	Order #	Description	Per Unit	12+	6+	1+
A	26-4135	Handle with 3 Tool Holders Set		\$30.50	\$31.82	\$33.15
B	26-4137	Replacement Holder	3 Pack	\$16.11	\$17.06	\$18.95
	26-4138	Traditional Holder	10 Pack	\$49.47	\$52.38	\$58.20
C	34-2233	Extra-Long	3 Pack	\$29.88	\$31.64	\$35.15
	34-2234	Extra-Long	10 Pack	\$98.52	\$104.31	\$115.90
D	34-2231	½" Round Holder	3 Pack	\$17.64	\$18.68	\$20.75
	34-2229	½" Round Holder	10 Pack	\$60.48	\$64.04	\$71.15
E	34-2232	Soft-Hit QC Holder	10 Pack	\$28.52	\$30.20	\$33.55



**CROCKER-PATTERN GRAVER SHARPENER**

Use to hold graver in a fixed position while sharpening on a bench stone. Graver can be set to any angle by setting index. Can also be locked in for repeated accuracy. Sharpening stone sold separately.

Item	Order #	Description	12+	6+	1+
F	36-8800	Graver Sharpener	\$41.23	\$43.65	\$48.50



**GRAVER SHARPENER**

Use to sharpen gravers. Place graver in either of two angled openings and then roll over a flat oilstone to sharpen. Sharpening stone not included.

Item	Order #	Description	12+	6+	1+
G	36-8840	Sharpener	\$7.48	\$7.92	\$8.80

**GRS® QUICK-CHANGE GRAVER HOLDER**

H. Organize your work area and protect your tools by utilizing this great storage system. It comes with 12 different color-coordinating trays and collars so that you can better organize your tools. Collars slide over the tools next to the quick-change tool holder. The color coding system saves time and keeps you organized. The trays are set at an angle for easy removal, and it is easier to see the graver points. The system holds 120 quick-change tools in a nice compact organized fashion. Includes small plastic magnifier. Get 12 different colored trays and color-coordinated collars to mark your tools. Each tray holds 10 tools and comes with 10 collars of each color. Includes small plastic magnifier.

Item	Order #	Description	Quantity	12+	6+	1+
H	26-4180	QC Storage System		—	—	\$53.00
J	26-4181	QC Storage Trays Set	12 Piece	\$33.99	\$35.47	\$36.95





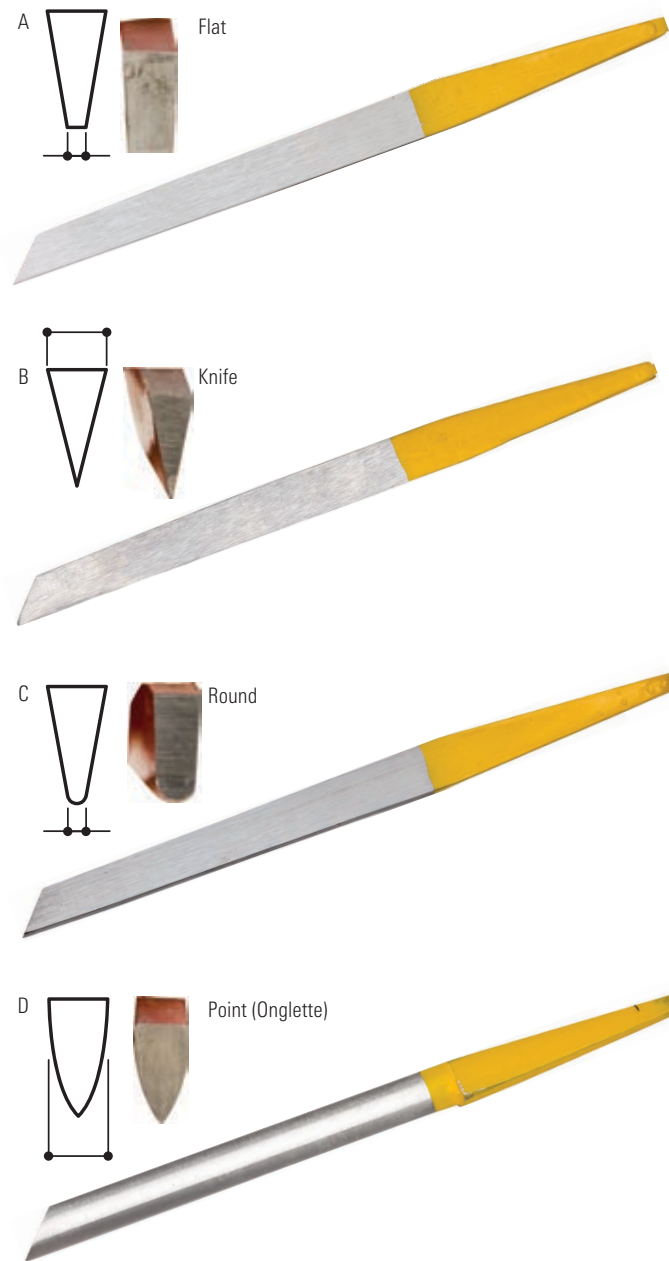

**GROBET USA® SWISS HIGH-SPEED STEEL GRAVERS**

Genuine, high-quality gravers are produced from special high-speed steel for long-lasting performance. Accept no substitutes.

**Order # 36-25500**

Item	Description	Style	Width	12+	6+	1+
A	Flat	#36	0.2mm	\$9.31	\$9.86	\$10.95
	Flat	#37	0.4mm	\$9.31	\$9.86	\$10.95
	Flat	#39	1mm	\$9.31	\$9.86	\$10.95
	Flat	#40	1.2mm	\$9.31	\$9.86	\$10.95
	Flat	#41	1.4mm	\$9.31	\$9.86	\$10.95
	Flat	#42	1.8mm	\$9.31	\$9.86	\$10.95
	Flat	#43	2mm	\$9.31	\$9.86	\$10.95
	Flat	#45	2.4mm	\$9.31	\$9.86	\$10.95
B	Knife	#1	1.8mm	\$11.82	\$12.51	\$13.90
	Knife	#2	2mm	\$11.82	\$12.51	\$13.90
	Knife	#3	2.2mm	\$11.82	\$12.51	\$13.90
	Knife	#4	2.4mm	\$11.82	\$12.51	\$13.90
	Knife	#5	2.6mm	\$11.82	\$12.51	\$13.90
C	Round	#50	0.2mm	\$9.31	\$9.86	\$10.95
	Round	#51	0.4mm	\$9.31	\$9.86	\$10.95
	Round	#52	0.6mm	\$9.31	\$9.86	\$10.95
	Round	#54	1mm	\$9.31	\$9.86	\$10.95
	Round	#55	1.2mm	\$9.31	\$9.86	\$10.95
	Round	#57	1.6mm	\$9.31	\$9.86	\$10.95
D	Point (Onglette)	#5/0	1.16mm	\$9.31	\$9.86	\$10.95
	Point (Onglette)	#4/0	1.24mm	\$9.31	\$9.86	\$10.95
	Point (Onglette)	#3/0	1.35mm	\$9.31	\$9.86	\$10.95
	Point (Onglette)	#2/0	1.45mm	\$9.31	\$9.86	\$10.95
	Point (Onglette)	#0	1.58mm	\$9.31	\$9.86	\$10.95
	Point (Onglette)	#1	1.78mm	\$9.31	\$9.86	\$10.95
	Point (Onglette)	#2	1.94mm	\$9.31	\$9.86	\$10.95
	Point (Onglette)	#3	2.16mm	\$9.31	\$9.86	\$10.95
	Point (Onglette)	#4	2.54mm	\$9.31	\$9.86	\$10.95
	Point (Onglette)	#5	2.74mm	\$9.31	\$9.86	\$10.95
	Point (Onglette)	#6	2.94mm	\$9.31	\$9.86	\$10.95
	Point (Onglette)	#8	3.36mm	\$9.31	\$9.86	\$10.95

**GRAVERS SHAPES WITH CUTTING ANGLES AND FACES**

- Flat** has a rectangular cross section with a flat cutting edge used to make flat bottom cuts.
- Square** has an equilateral square set on its corner so the lower corner cuts the metal.
- Lozenge** has a rhombus shape with two acute and two obtuse angles for making "V" cuts with an acute angle.
- Onglette** is triangular in shape with slightly rounded sides that form a point along the bottom.
- Knife** has an acute triangular shape used to make deep, narrow V-shaped cuts.
- Round** has flat sides and a rounded bottom used to cut rounded grooves and raise beads.
- Oval** has an oval shape and is used to produce U-shaped cuts.
- Liner** has a similar shape to the flat but with shallow parallel grooves running along its bottom edge.
- Dotter** has a rectangular shaft with a flat top and rounded bottom used to make dots or round bottomed cuts.

*Always wear eye protection when shaping and sharpening.*



**GROBET USA® SWISS QUICK-CHANGE GRAVERS**

Pre-shaped, quick-change gravers are designed to fit the GRS® Quick-Change Tool Holder for use with the GRS Quick-Change Handpieces. They also work with the Foredom® PowerGraver™ and the MagnaGravers™. Made from special, high-speed steel to ensure long lasting performance. Genuine, Swiss-made with the yellow tang. Accept no substitutes.

**A. Engraving Kit**

Includes 11 Gravers:  
36-2722, 36-2724, 36-2726, 36-2701, 36-2702,  
36-2705, 36-2708, 36-2712, 36-2713, 36-2734, and 36-2736.

**B. Stone Setting Kit**

Includes 11 Gravers:  
36-2722, 36-2723, 36-2724, 36-2701, 36-2705,  
36-2708, 36-2711, 36-2712, 36-2713, 36-2734, and 36-2736.

Kits	Description	12+	6+	1+
A	<b>36-2740</b> Engraving Kit	\$93.50	\$99.00	\$110.00
B	<b>36-2741</b> Stone Setting Kit	493.50	\$99.00	\$110.00

**Order # 36-27000**

Item	Description	Style	Width	12+	6+	1+
C	Flat Edge	#36	0.2mm	\$9.27	\$9.81	\$10.90
	Flat Edge	#37	0.4mm	\$9.27	\$9.81	\$10.90
	Flat Edge	#38	0.6mm	\$9.27	\$9.81	\$10.90
	Flat Edge	#38	0.8mm	\$9.27	\$9.81	\$10.90
	Flat Edge	#39	1mm	\$9.27	\$9.81	\$10.90
	Flat Edge	#40	1.2mm	\$9.27	\$9.81	\$10.90
	Flat Edge	#41	1.4mm	\$9.27	\$9.81	\$10.90
	Flat Edge	#41	1.6mm	\$9.27	\$9.81	\$10.90
	Flat Edge	#42	1.8mm	\$9.27	\$9.81	\$10.90
	Flat Edge	#43	2mm	\$9.27	\$9.81	\$10.90
	Flat Edge	#45	2.4mm	\$9.27	\$9.81	\$10.90
D	Knife	#18	1.8mm	\$9.27	\$9.81	\$10.90
	Knife	#20	2mm	\$9.27	\$9.81	\$10.90
	Knife	#1	2.2mm	\$9.27	\$9.81	\$10.90
	Knife	#2	2.6mm	\$9.27	\$9.81	\$10.90
E	Round	#50	0.2mm	\$9.27	\$9.81	\$10.90
	Round	#52	0.6mm	\$9.27	\$9.81	\$10.90
	Round	#52	0.8mm	\$9.27	\$9.81	\$10.90
	Round	#53	1mm	\$9.27	\$9.81	\$10.90
F	Point	#5/0	1.16mm	\$9.27	\$9.81	\$10.90
	Point	#4/0	1.24mm	\$9.27	\$9.81	\$10.90
	Point	#3/0	1.35mm	\$9.27	\$9.81	\$10.90
	Point	#2/0	1.45mm	\$9.27	\$9.81	\$10.90
	Point	#0	1.58mm	\$9.27	\$9.81	\$10.90
	Point	#1	1.78mm	\$9.27	\$9.81	\$10.90
	Point	#2	1.94mm	\$9.27	\$9.81	\$10.90
	Point	#3	2.16mm	\$9.27	\$9.81	\$10.90
	Point	#4	2.54mm	\$9.27	\$9.81	\$10.90

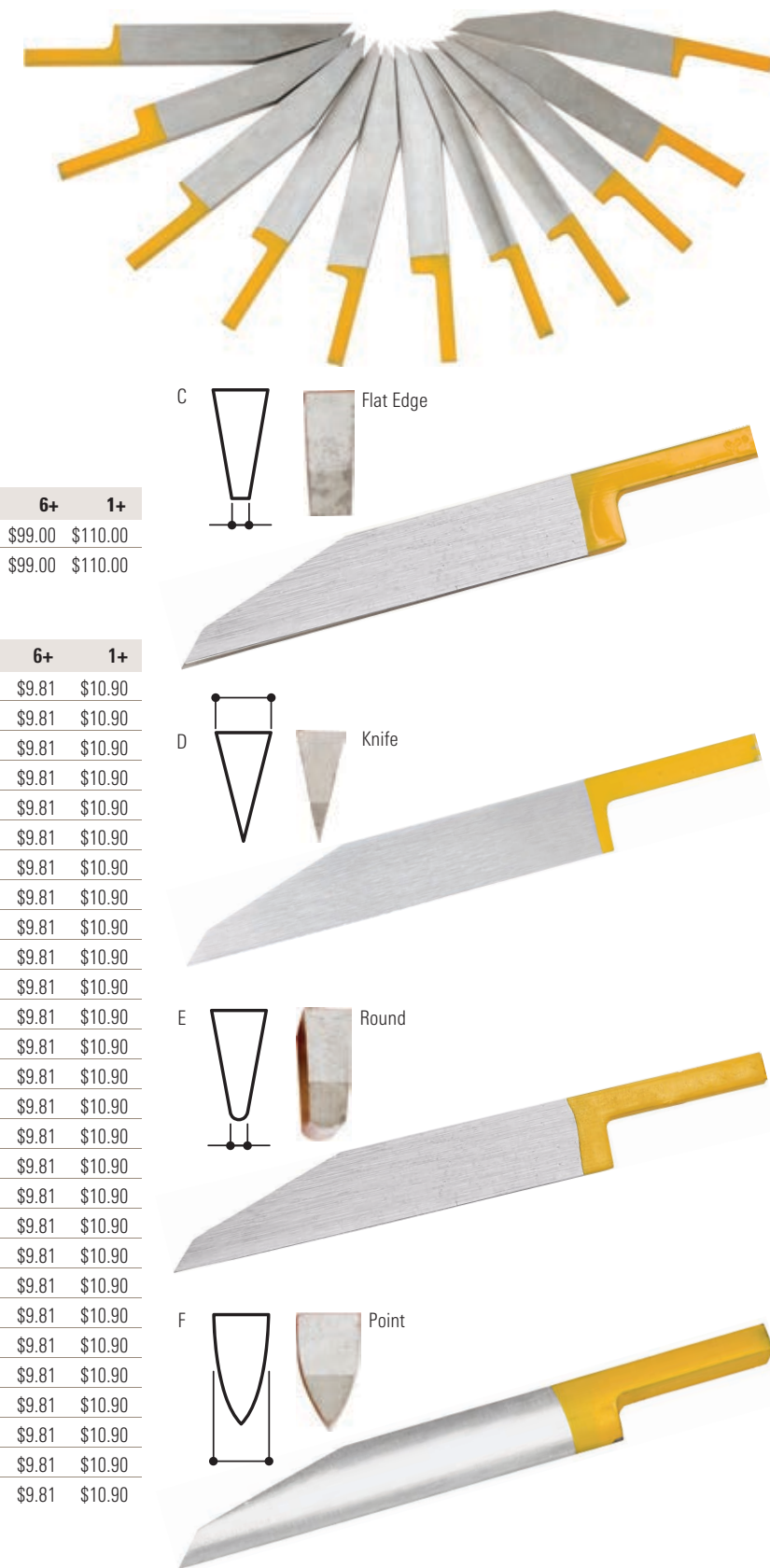

**MULLER® HIGH-SPEED GRAVERS**

Quality E.C. Muller graters hold an edge up to five times longer than carbon-steel graters. Generally preferred for use on gold, platinum, silver, and steel. These graters can be modified to be used with all power-assisted engraving systems and handpieces, including GRS® and Foredom® systems.

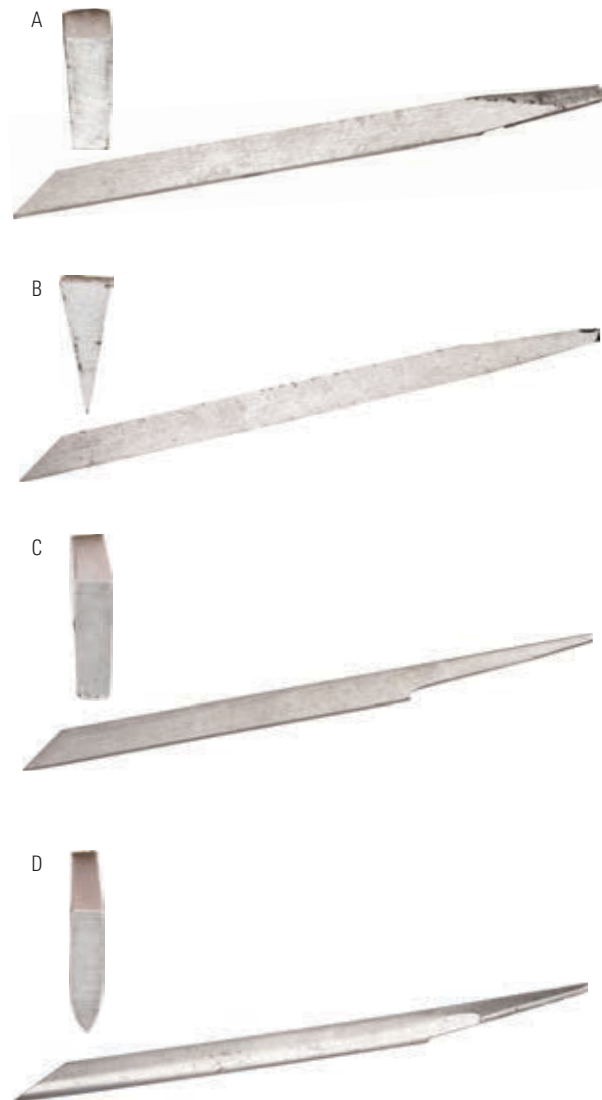

- FLAT**
- 36
- 37
- 38
- 39
- 40
- 41
- 42
- 43
- 44
- 45
- KNIFE**
- 1/0
- 1
- 2
- 3
- ROUND**
- 50
- 51
- 52
- 53
- 54
- 55
- 56
- 57
- 58
- BEVEL**
- 1
- 2
- 3
- POINT**
- 2/0
- 1/0
- 1
- 2
- 3
- 4
- 5

**Order # 36-35000**

Item	Description	Style	Width	12+	6+	1+
A	Flat	#36	0.35mm	\$6.21	\$6.57	\$7.30
	Flat	#37	0.45mm	\$6.21	\$6.57	\$7.30
	Flat	#38	0.55mm	\$6.21	\$6.57	\$7.30
	Flat	#39	0.67mm	\$6.21	\$6.57	\$7.30
	Flat	#40	1mm	\$6.21	\$6.57	\$7.30
	Flat	#41	1.25mm	\$6.21	\$6.57	\$7.30
	Flat	#42	1.35mm	\$6.21	\$6.57	\$7.30
	Flat	#43	1.6mm	\$6.21	\$6.57	\$7.30
	Flat	#45	2mm	\$6.21	\$6.57	\$7.30
B	Knife	#1/0	1.2mm	\$6.21	\$6.57	\$7.30
	Knife	#1	1.45mm	\$6.21	\$6.57	\$7.30
	Knife	#2	1.65mm	\$6.21	\$6.57	\$7.30
	Knife	#3	1.7mm	\$6.21	\$6.57	\$7.30
C	Round	#50	0.27mm	\$6.21	\$6.57	\$7.30
	Round	#51	0.38mm	\$6.21	\$6.57	\$7.30
	Round	#52	0.5mm	\$6.21	\$6.57	\$7.30
	Round	#53	0.8mm	\$6.21	\$6.57	\$7.30
	Round	#54	1mm	\$6.21	\$6.57	\$7.30
	Round	#57	1.5mm	\$6.21	\$6.57	\$7.30
	Bevel	#1	1.45mm	\$6.21	\$6.57	\$7.30
	Bevel	#2	1.65mm	\$6.21	\$6.57	\$7.30
	Bevel	#3	1.7mm	\$6.21	\$6.57	\$7.30
D	Point (Onglette)	#2/0	0.6mm	\$6.21	\$6.57	\$7.30
	Point (Onglette)	#1/0	0.85mm	\$6.21	\$6.57	\$7.30
	Point (Onglette)	#1	1.1mm	\$6.21	\$6.57	\$7.30
	Point (Onglette)	#2	1.27mm	\$6.21	\$6.57	\$7.30
	Point (Onglette)	#3	1.35mm	\$6.21	\$6.57	\$7.30
	Point (Onglette)	#4	1.5mm	\$6.21	\$6.57	\$7.30
	Point (Onglette)	#5	1.55mm	\$6.21	\$6.57	\$7.30

**TEMPERING TEMPERATURES**

Color on Polished Steel	°F	°C	Temperature	Tool Type
Light Straw	400°	204°	Very High	Gravers, Files
Straw Yellow	428°	220°	High	Scrapers, Twist Drills, Razors
Golden Yellow	469°	242°		Cold Chisels, Hammer Faces
Dark Brown-Bronze	500°	260°	Medium	Drills
Purple or Peacock	531°	277°		Chasing Punches, Springs, Dies
Full Dark Blue	550°	287°	Low	Hot Chisels, Knives
Pale Blue	610°	321°		Saw Blades, Screwdrivers
Gray-Black	630°	332°	Soft to Dead Soft	Too Soft for Steel Tools

Graver Type	Normal Cutting Angle	Number of Set-Off Faces	Angle of Set-Off Faces
Flat	30°- 45°	0	0
Square	30°- 45°	2	5°- 10°
Lozenge	30°- 45°	2	5°- 10°
Onglette	30°- 45°	0	0
Knife	30°- 45°	2	5°- 10°
Round	60°- 65°	0	0
Oval	60°- 65°	0	0
Liner	30°- 45°	0	0
Dotter	30°- 45°	0	0

**Order # 36-26450**

Item	Description	Style	Width	Length	12+	6+	1+
A	Tapered Flat	#36	0.2mm	1½"	\$16.96	\$17.96	\$19.95
	Tapered Flat	#38	0.6mm	1½"	\$15.26	\$16.16	\$17.95
	Tapered Flat	#40	1mm	1½"	\$14.41	\$15.26	\$16.95
	Tapered Flat	#37	0.4mm	1½"	\$15.26	\$16.16	\$17.95
	Tapered Flat	#41	1.2mm	1½"	\$14.41	\$15.26	\$16.95
B	Tapered Round	#51	0.4mm	1½"	\$16.11	\$17.06	\$18.95
	Tapered Round	#52	0.6mm	1½"	\$16.11	\$17.06	\$18.95
	Tapered Round	#53	0.8mm	1½"	\$16.11	\$17.06	\$18.95
C	Flat Parallel	#44	1.8mm	1½"	\$14.41	\$15.26	\$16.95
	Flat Parallel	#42	1.4mm	1½"	\$14.41	\$15.26	\$16.95
	Flat Parallel	#41	1.2mm	1½"	\$14.41	\$15.26	\$16.95
	Flat Parallel	#40	1mm	1½"	\$14.41	\$15.26	\$16.95
	Flat Parallel	#39	0.8mm	1½"	\$15.26	\$16.16	\$17.95
	Flat Parallel	#38	0.6mm	1½"	\$15.26	\$16.16	\$17.95
D	Onglette	#0	Nullmm	1½"	\$15.26	\$16.16	\$17.95
	Onglette	#2	Nullmm	1½"	\$14.41	\$15.26	\$16.95



**MULLER STRAIGHT LINE GRAVERS**

Genuine E.C. Muller quality grade line graters are made of high carbon tool steel and are essential for performing various engraving techniques, some of which include florentine, shading, stippling, and background work. Suitable for work on flat or convex surfaces, these graters can be used on most metals, wood, bone, ivory, and onyx. Made in the USA. Graters are ordered by indicating the grade first, which is the distance between the lines. The second number indicates the number of lines required on the liner. Grade 8 is the finest line (smallest distance between the lines) and 26 is the thickest line (farthest distance between the lines).

**Order # 36-65000**

Style	Width	Lines	12+	6+	1+
#8	1.63mm	6	\$15.94	\$16.88	\$18.75
#8	0.8mm	8	\$15.94	\$16.88	\$18.75
#8	1.2mm	10	\$15.94	\$16.88	\$18.75
#12	0.79mm	4	\$15.94	\$16.88	\$18.75
#12	1.13mm	6	\$15.94	\$16.88	\$18.75
#12	1.41mm	8	\$15.94	\$16.88	\$18.75
#12	1.83mm	12	\$15.94	\$16.88	\$18.75
#14	0.83mm	4	\$15.94	\$16.88	\$18.75
#14	1.6mm	8	\$15.94	\$16.88	\$18.75
#14	2.2mm	12	\$15.94	\$16.88	\$18.75
#16	1.3mm	6	\$17.72	\$18.77	\$20.85
#16	1.76mm	8	\$17.72	\$18.77	\$20.85
#20	1.6mm	6	\$17.72	\$18.77	\$20.85
#20	2.64mm	10	\$17.72	\$18.77	\$20.85

**C-MAX GRAVERS**

A-C. Strong demand has led to the development of additional C-Max graters. With these three new styles, users have even more options. These graters feature a 1/8"-round shank and are made with the same GRS C-Max carbide as the new C-Max Onglettes.

D. C-Max Onglette works well for jewelry work, stone setting, and general engraving. The carbide material for C-Max graters provides a superior edge to traditional tool metals. Try one today and see the difference for yourself.

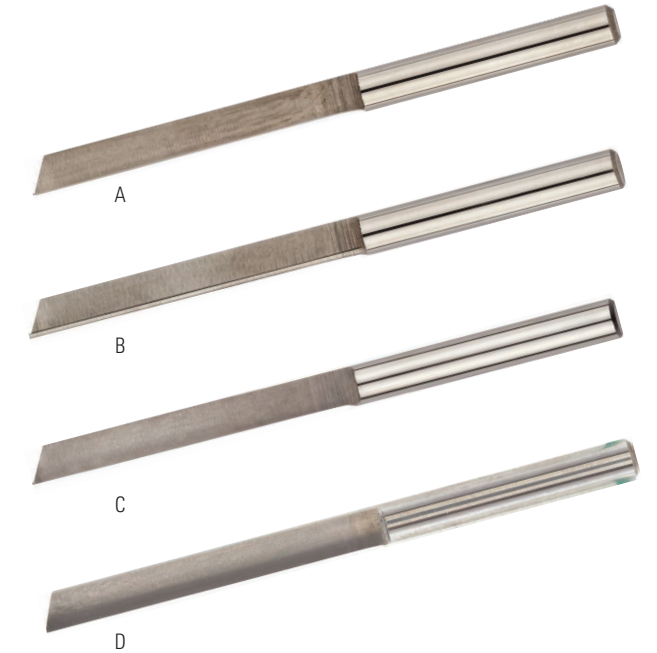

**E.C. MULLER BENT LINE GRAVERS**

These high carbon tool steel graters are designed for concave surfaces with 6 as the finest and 16 being the thickest grade.

**Order # 36-12000**

Style	Width	Lines	12+	6+	1+
#6	0.4mm	4	\$16.79	\$17.78	\$19.75
#8	0.72mm	4	\$16.79	\$17.78	\$19.75
#12	1.15mm	6	\$16.79	\$17.78	\$19.75
#12	1.41mm	8	\$16.79	\$17.78	\$19.75
#16	1.76mm	8	\$16.79	\$17.78	\$19.75





**GLENSTEEL GRAVERS**

GRS® now offers V-shaped gravers made from GlenSteel high-speed steel for engravers, stone setters, and jewelers. These new tools have a precision ground V-point geometry on one end with a convenient 3/32" square shank on the other. GlenSteel features outstanding toughness to resist breaking and chipping, even in slender, fine shapes. An excellent all-around choice for professionals and hobbyists when a tough graver is needed. It is also cobalt-free, so you are not exposed to cobalt dust when sharpening. Also for use with Lindsay templates.

**Order # 36-25400**

Item	Description	Width	Length	12+	6+	1+
A	V-Point Graver 60°	1.98mm	2 1/2"	\$16.02	\$16.97	\$18.85
B	V-Point Graver 75°	1.98mm	2 1/2"	\$16.02	\$16.97	\$18.85
C	V-Point Graver 105°	1.98mm	2 1/2"	\$16.02	\$16.97	\$18.85
D	V-Point Graver 120°	1.98mm	2 1/2"	\$16.02	\$16.97	\$18.85
E	A1 Square Graver	2.35mm	2 3/4"	\$12.71	\$13.46	\$14.95
F	A2 Flat Graver	2.35mm	2 3/4"	\$12.71	\$13.46	\$14.95
G	A3 Blank Graver	2.35mm	2 3/4"	\$11.86	\$12.56	\$13.95



**C-MAX CARBIDE GRAVERS**

A tungsten carbide graver with the right blend of hardness and toughness for hand engraving and stone setting applications. C-Max achieves a metallurgical balance like no other carbide. These don't break easily and definitely hold a fine edge.

**Order # 36-26410**

Item	Description	Width	Length	12+	6+	1+
H	V-Point Graver 75°	1.98mm	2"	\$19.42	\$20.57	\$22.85
J	V-Point Graver 90°	1.98mm	2"	\$19.42	\$20.57	\$22.85
K	V-Point Graver 105°	1.98mm	2"	\$19.42	\$20.57	\$22.85
L	V-Point Graver 120°	1.98mm	2"	\$19.42	\$20.57	\$22.85
M	Round Blank Graver	1.98mm	2"	\$6.42	\$6.80	\$7.55
N	2mm Square Blank	1.98mm	2"	\$14.88	\$15.75	\$17.50
P	3/32" Square Blank	1.98mm	2"	\$15.30	\$16.20	\$18.00



**GRS® TUNGSTEN-CARBIDE GRAVERS**

These are much harder than any tool steel but more brittle. They last up to 10 times longer between sharpenings when properly used. Sharpen with a diamond wheel.

Item	Order #	Description	Width	Length	12+	6+	1+
Q	36-2548	Square Carbide	2.2mm	2"	\$9.35	\$9.90	\$11.00
R	36-2549	Blank Carbide	2.2mm	2"	\$9.35	\$9.90	\$11.00

**GRS® CARBIDE BLANK AND BURNISHER TOOLS**

Precision tungsten-carbide tools for texturing and burnishing.

Burnish Tool – Special tool is used for burnishing or gypsy stone setting.

Item	Order #	Description	Width	Length	12+	6+	1+
A	36-2609	Carbide Burnish Tool	1.98mm	2"	\$20.40	\$21.60	\$24.00

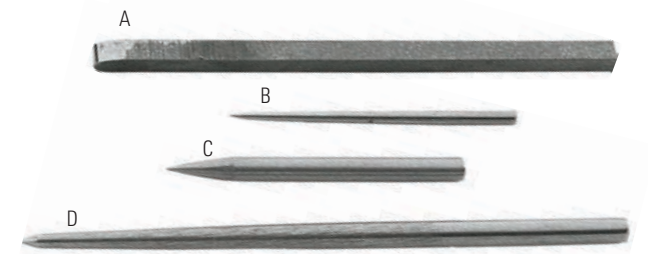

**GRS® HEAT-TREATED HARDENED STEEL POINTS**

Easily made into special punches, hammer tools, bead raisers, prong pushers, stipple points, and more. All points are properly hardened.

**Order # 36-25950**

Item	Width	Length	12+	6+	1+
B	1.8mm	1 1/2"	\$6.29	\$6.66	\$7.40
C	3.1mm	1 1/2"	\$8.12	\$8.60	\$9.55
D	3.3mm	3"	\$10.16	\$10.76	\$11.95



**MIRROR FINISH POLISHER**

Provides a perfect mirror finish on carbide and HSS gravers.

Item	Order #	Description	12+	6+	1+
E	11-6010	Diamond Polishing Wheel	\$42.14	\$43.97	\$45.80
F	11-6022	Gray Roughing Diamond Wheel	–	–	\$34.95
G	11-6023	Blue Medium Diamond Wheel	–	–	\$42.50

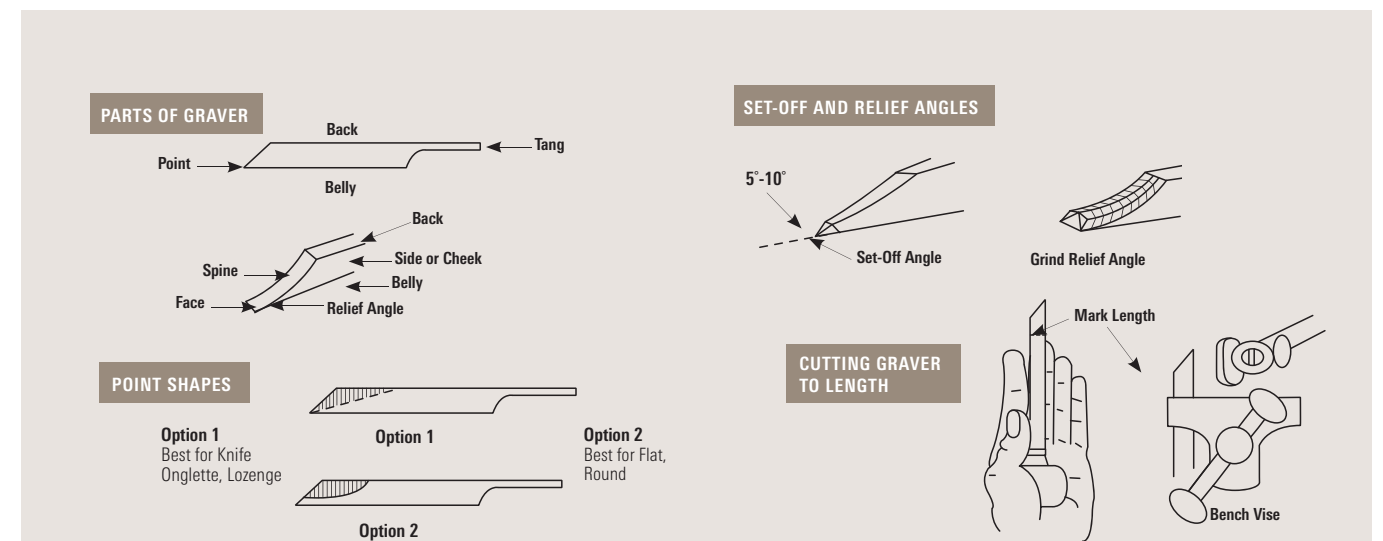



**MAGNA-GRAVER®**

This impact handpiece is recommended for use with the Foredom® L Motor, but can also be used with other flexible shafts. It features a one piece, 1/8" output shaft that holds shank tools with a set screw. Designed for use with Magna-Graver® gravers or custom tools fashioned from 1/8" tool steel rod. Gravers sold separately. Made in the USA.

Order #	Description	Length	1+
36-8801	Magna-Graver	5 3/4"	\$249.60



**BURGESS™ VIBRO-GRAVER**

Rugged, industrial-quality engraving tool makes permanent markings on almost any hard surface. Can also be used to make background effects. Features durable, tungsten-carbide engraving tip, an on/off switch, and a spark-free motor that vibrates at 7,200 strokes per minute. Adjustment dial changes length of stroke and depth of mark. Includes carbide bit. Diamond bit not included.

Order #	Description	12+	6+	1+
36-8000	Vibro-Graver 110V	\$47.60	\$50.40	\$56.00



**FIREARMS ENGRAVING TRANSFER SYSTEM WINCHESTER UBERTI 1873**

This transfer system makes it easy for the engraver to establish proper and credible styles on a Winchester Uberti 1873 Firearm. Scroll images can be easily transferred from the included transfer sheet directly to the surface of the firearm. Each Kit Includes how to apply instructions which includes information on schematic drawings, illustration, and how to place the numbered scroll patterns upon the various surfaces of the subject firearm. Transfer Sheet(s) - These clear vinyl sheets have scroll patterns printed on the surface that are transferred to the metal surfaces by the user. Casting A - A plastic casting of Mike Dubber's original steel master plate, which shows the user how to execute and detail the scrolls cut from the Transfer Sheets.

Order #	Description	12+	6+	1+
21-0555	Firearms Engraving Transfer System Winchester Uberti 1873	\$148.75	\$157.50	\$175.00

**MOUNTED ARKANSAS BENCH STONE**

Sharpening tools such as gravers and knives with excellent results due to the close-density oilstone qualities. Mounted in cedar box.

Order #	Grit	W×L×H	1+
10-5510	Fine	2"×4"×1/2"	\$19.55
10-5520	Extra-Fine	2"×4"×1/2"	\$46.40



**RUBY BENCH STONES**

Works well for sharpening and flattening hard metals as well as glass, quartz, and porcelain.

Item	Order #	Description	Grit	W×L×H	1+
A	10-4203	1-Sided Boxed	Medium	1"×4"×3/8"	\$105.10
B	10-4204	1-Sided Boxed	Fine	1"×4"×3/8"	\$134.65
C	10-4210	2-Sided Loose	Medium	1"×4"×3/8"	\$136.70

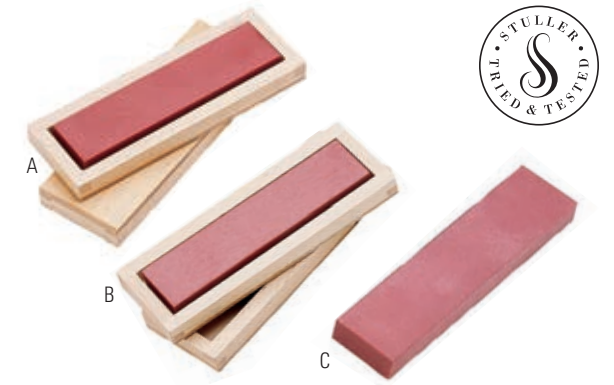

**COMBINATION INDIA BENCH STONE**

One side has fine grit, and the other side is coarse. This man-made stone features a tough, aluminum-oxide abrasive that enables fast-cutting.

Item	Order #	W×L×H	1+
D	10-4573	1 3/4"×4"×5/8"	\$17.50
E	10-4510	2"×6"×1"	\$26.80

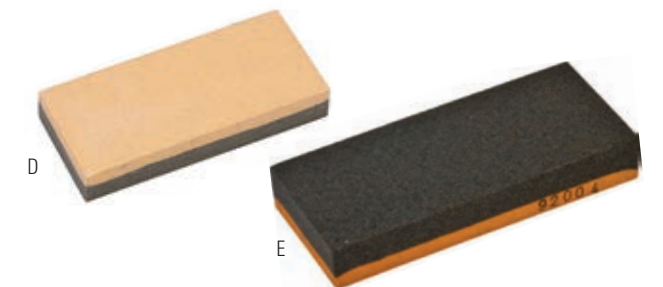

**NORTON SHARPENING STONE OIL**

Use as sharpening oil or for general purposes.

Order #	Description	Size	12+	6+	1+
10-6015	Norton Sharpening Oil	4 1/2 oz	\$8.51	\$8.88	\$9.25



**GRAVER LUBE KIT**

Extend graver life and brighten cuts. Sharpen your graver less and your work will look better. Includes lube container with lid and sponge.

Order #	Description	Size	1+
10-4555	Graver Lube Oil Kit	4 oz	\$11.00





## FILES

## FILE SHAPES

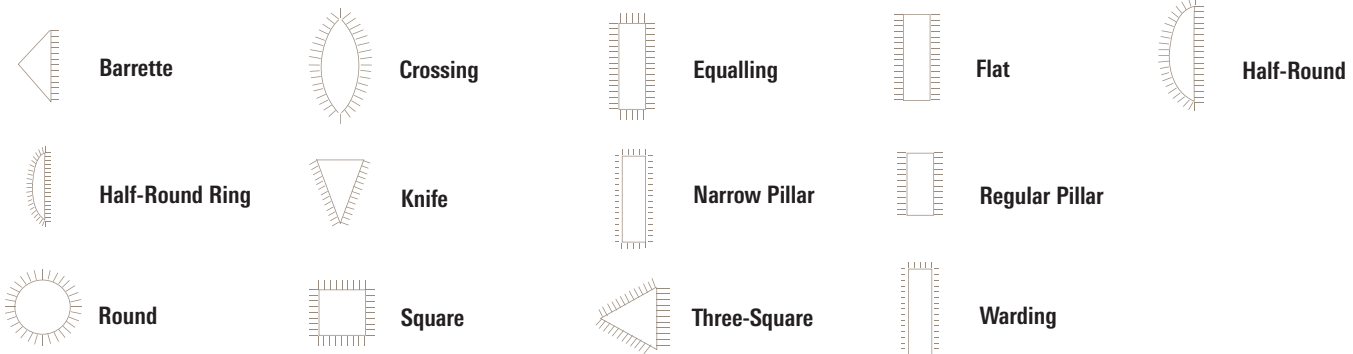

## Scale of Cuts



TEETH PER CM	12	16	20	25	31	38	46	56	68	84	116
TEETH PER INCH	30	41	51	64	79	97	117	142	173	213	295
Escapement Files				0		2		4	6		
Handle Files		00		1							
Needle Files			00	0	1	2	3	4	6		
Precision Files (w/tang) 10"/250mm	00	0	1	2	3	4		6			
Precision Files (w/tang) 4"-8"/100-200mm		00	0	1	2	3	4		6		
Precision Files 3"/76mm			00	0	1	2	3	4		3	8
Rifflers, Die Sinkers				0		2		4			

## FILE FACTS

- Italian Files are one size up from Swiss Files.
- The most common sizes used by jewelers are from 6 to 8 inches for the tang files and 5½ to 6¼ inches for the needle files. The escapement files are available only in 5¼ inches.
- On difficult material, such as platinum, it is recommended that a coated file be used such as a Grobet USA Premium file. The coating will provide non-clogging on sticky materials.
- Files kept in drawers, where they can bang into or slide over one another, will result in dulling and chipping of the teeth. Files should always be kept in the original packaging.
- Files are designed to cut on the push stroke, or, better yet, the file should be lifted from the surface entirely to allow filings to fall from the teeth as well as to minimize dulling.
- Grease or oils can be removed through the application of chalk, which absorbs them.
- Files should never be oiled for use.
- Never hold files by their teeth. Perspiration can cause the file to rust, and the oil from your skin can cause the file to skip.

## GROBET USA® WAX FILES

Use for shaping waxes. Coarse, wide-tooth style does not clog as easily as conventional files. Set of six includes one of each shape. Sold in plastic pouch.



Order #	Description	Length	12+	6+	1+
33-9220	6-Piece Wax File Set	5½"	\$46.81	\$49.56	\$55.07



## DOUBLE-ENDED WAX FILE

Double-end, double-cut file that has open, coarse teeth used for filing plastics, waxes, and soft materials. One end is coarser than the other.

Item	Order #	Length	Width	12+	6+	1+
A	31-3840	8"	14mm	\$35.66	\$37.76	\$41.95
B	31-3850	7"	12.7mm	\$25.71	\$27.23	\$30.25



## WAX CARVING FILE SET

Precision wax carving files with pointed tips for fine work. Each file features single cuts, which will not clog, but will leave a smooth surface. Made of stainless steel with Sure-Grip® Handles.

Order #	Description	Length	12+	6+	1+
33-9240	3-Piece Wax Carving Kit	5½"	\$14.88	\$15.75	\$17.50

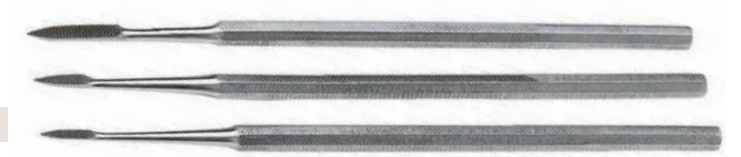

## SELECTING THE RIGHT FILE FOR THE JOB

In choosing the correct file for any application, three factors need to be considered: shape, size, and cut. Shape and size are more a choice of application, but generally the shape of the file should match the contour of the object being filed. In selecting the cut, it is important to know that files are made in a range of tooth characteristic cuts.

## The two cuts most common to the jeweler are—

**Chisel-Cut** — Chisel-cut files are the best choice for fast removal, as the cut or number of teeth per inch will be higher; however, they tend to leave a rough surface. The angle of the chisel-cut is 52-72 degrees.

**Edge-Cut** — Edge-cut files are generally used for finishing or fine finishing according to the chosen cut or number of teeth per inch. They can run from about 22 teeth per inch in coarse-cut files. Numbers ranging from 00 to 4 grade files are used most by jewelers, 8 is the finest cut and will be requested by watchmakers. The angle of the edge-cut is 50-55 degrees.

## Other cuts available to the jeweler are—

**Single-Cut** — Use on very thin sections of the work piece with light pressure. Available in needle file shapes in cut 2, equivalent to 96 teeth per inch, the most common cut for such applications.

**Double-Cut** — Double-cut files have two series of teeth: one series cuts in much the same manner as a single-cut file, and the second crosses over the first one with a 45-50 degree angle to shape the chip breaker and the teeth. The chip breaker will avoid having to long chip which may scratch the work piece.

**Rasp-Cut** — Usually confined to wax work.



**GROBET USA® GENUINE SWISS-PATTERN HAND FILES**

Known and recognized worldwide as unsurpassed for exceptional durability, these files exhibit extreme hardness due to chrome-alloy steel and unique manufacturing process.

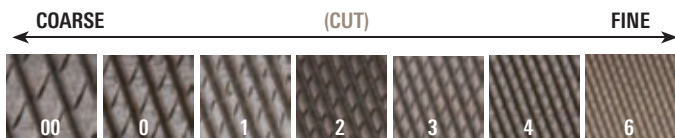

**HALF-ROUND** Tapered in width and thickness, coming to a point. Cut on both sides.

Order #	Cut	Width	Length	Thickness	12+	6+	1+
31-1110	00	5/8"	6"	1 1/4mm	\$25.46	\$26.96	\$29.95
31-1120	0	5/8"	6"	1 1/4mm	\$25.46	\$26.96	\$29.95
31-1131	1	5/8"	6"	1 1/4mm	\$27.16	\$28.76	\$31.95
31-1142	2	5/8"	6"	1 1/4mm	\$27.84	\$29.48	\$32.75

Order #	Cut	Width	Length	Thickness	12+	6+	1+
31-1153	3	5/8"	6"	1 1/4mm	\$29.71	\$31.46	\$34.95
31-1164	4	5/8"	6"	1 1/4mm	\$31.45	\$33.30	\$37.00
31-1176	6	5/8"	6"	1 1/4mm	\$47.60	\$50.40	\$56.00



**HALF-ROUND RING** Tapered in width and thickness, coming to a point. Useful in filing the inside of rings. Cut on both sides.

Order #	Cut	Width	Length	Thickness	12+	6+	1+
31-1271	00	1 5/32"	6"	5/4mm	\$27.63	\$29.25	\$32.50
31-1280	0	1 5/32"	6"	5/4mm	\$27.63	\$29.25	\$32.50
31-1291	1	1 5/32"	6"	5/4mm	\$28.48	\$30.15	\$33.50

Order #	Cut	Width	Length	Thickness	12+	6+	1+
31-1302	2	1 5/32"	6"	5/4mm	\$28.48	\$30.15	\$33.50
31-1313	3	1 5/32"	6"	5/4mm	\$29.33	\$31.05	\$34.50
31-1324	4	1 5/32"	6"	5/4mm	\$39.53	\$41.85	\$46.50



**BARRETTE** Tapered in width and thickness, coming to a point. Only flat side is cut, providing safe edge and top.

Order #	Cut	Width	Length	Thickness	12+	6+	1+
31-0271	00	5/8"	6"	5/32mm	\$19.34	\$20.48	\$22.75
31-0280	0	5/8"	6"	5/32mm	\$20.19	\$21.38	\$23.75
31-0291	1	5/8"	6"	5/32mm	\$22.74	\$24.08	\$26.75

Order #	Cut	Width	Length	Thickness	12+	6+	1+
31-0302	2	5/8"	6"	5/32mm	\$23.38	\$24.75	\$27.50
31-0314	4	5/8"	6"	5/32mm	\$26.14	\$27.68	\$30.75



**REGULAR PILLAR** Parallel in width and tapered in thickness. Perfect for inside square cuts and filing slots.

Order #	Cut	Width	Length	Thickness	12+	6+	1+
31-2430	00	3 3/64"	6"	5/32mm	\$15.34	\$16.25	\$18.05
31-2440	0	3 3/64"	6"	5/32mm	\$15.47	\$16.38	\$18.20
31-2451	1	3 3/64"	6"	5/32mm	\$16.24	\$17.19	\$19.10

Order #	Cut	Width	Length	Thickness	12+	6+	1+
31-2462	2	3 3/64"	6"	5/32mm	\$14.37	\$15.21	\$16.90
31-2484	4	3 3/64"	6"	5/32mm	\$19.51	\$20.66	\$22.95
31-2496	6	3 3/64"	6"	5/32mm	\$29.45	\$31.19	\$34.65



**NARROW PILLAR** These files are parallel in width and tapered in thickness to create perfectly flat filing. Double-cut on top and bottom, both edges are safe.

Order #	Cut	Width	Length	Thickness	12+	6+	1+
31-2132	2	2 5/64"	8"	1 1/4mm	\$23.63	\$25.02	\$27.80



**CROSSING** Half-round on two sides, with one side having a larger radius than the other. Tapered in width and thickness. Cut and usable to the point. Used primarily for filing interior curved surfaces.

Order #	Cut	Width	Length	Thickness	12+	6+	1+
31-0590	0	5/8"	6"	1 1/4mm	\$38.04	\$40.28	\$44.75
31-0602	2	5/8"	6"	1 1/4mm	\$40.80	\$43.20	\$48.00



**EQUALLING** Parallel in width and thickness. Used primarily for filing slots and corners.

Order #	Cut	Width	Length	Thickness	12+	6+	1+
31-0680	00	1/2"	6"	5/32mm	\$19.34	\$20.48	\$22.75
31-0690	0	1/2"	6"	5/32mm	\$19.13	\$20.25	\$22.50

Order #	Cut	Width	Length	Thickness	12+	6+	1+
31-0702	2	1/2"	6"	5/32mm	\$19.98	\$21.15	\$23.50
31-0714	4	1/2"	6"	5/32mm	\$22.53	\$23.85	\$26.50



**PILLAR CHECKERING**

Order #	Cut	Width	Length	Thickness	12+	6+	1+
31-2117	00	1/2"	6"	5/32mm	\$32.94	\$34.88	\$38.75
31-2118	0	1/2"	6"	5/32mm	\$32.94	\$34.88	\$38.75

Order #	Cut	Width	Length	Thickness	12+	6+	1+
31-2120	2	1/2"	6"	5/32mm	\$32.94	\$34.88	\$38.75
31-2121	4	1/2"	6"	5/32mm	\$50.11	\$53.06	\$58.95



**FLAT** Parallel in width and thickness. One edge is safe.

Order #	Cut	Width	Length	Thickness	12+	6+	1+
31-1431	00	4 5/64"	6"	5/32mm	\$15.30	\$16.20	\$18.00
31-1440	0	4 5/64"	6"	5/32mm	\$16.24	\$17.19	\$19.10
31-1451	1	4 5/64"	6"	5/32mm	\$16.41	\$17.37	\$19.30
31-1462	2	4 5/64"	6"	5/32mm	\$16.49	\$17.46	\$19.40

Order #	Cut	Width	Length	Thickness	12+	6+	1+
31-1473	3	4 5/64"	6"	5/32mm	\$18.66	\$19.76	\$21.95
31-1484	4	4 5/64"	6"	5/32mm	\$20.53	\$21.74	\$24.15
31-1496	6	4 5/64"	6"	5/32mm	\$30.39	\$32.18	\$35.75



**THREE-SQUARE** Gradually tapered, cut, and workable to the point.

Order #	Cut	Width	Length	Thickness	12+	6+	1+
31-3720	0	2 3/64"	6"	4mm	\$18.28	\$19.35	\$21.50
31-3731	1	2 3/64"	6"	4mm	\$18.28	\$19.35	\$21.50

Order #	Cut	Width	Length	Thickness	12+	6+	1+
31-3742	2	2 3/64"	6"	4mm	\$19.34	\$20.48	\$22.75
31-3754	4	2 3/64"	6"	4mm	\$21.68	\$22.95	\$25.50

**FILE CLEANER**

Features steel wire bristles mounted on a wooden handle. Works great in removing small particles that clog teeth and reduce a files ability to cut.

Order #	Length	12+	6+	1+
33-9810	10"	\$8.33	\$8.82	\$9.80







## BARRETTE PARALLEL NEEDLE FILE

Order #	Cut	Length	Cutting Length	12+	6+	1+
31-7106	6	5½"	1¾"	\$16.28	\$17.24	\$19.15



## SCREW-HEAD FILE

Order #	Cut	Length	Cutting Length	12+	6+	1+
59-1038	6	3"	2½"	\$25.12	\$26.60	\$29.55

## GROBET USA® PREMIUM HAND FILES

Grobet USA® has the highest execution standard on files. The surface has a Rockwell hardness of 72HRC, the hardest steel known. These files will give a better performance on hard-to-file surfaces. They are resistant to corrosion—no need to grease these files—and have a longer life than the standard file. Excellent for use on platinum. Use 37-8794 file handle.

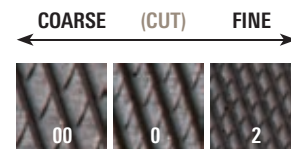

## PILLAR

Order #	Cut	Length	Cutting Length	12+	6+	1+
31-8056	0	6"	5¾"	\$23.63	\$25.02	\$27.80



## HALF-ROUND

Order #	Cut	Length	Cutting Length	12+	6+	1+
31-8060	0	6"	5¾"	\$34.85	\$36.90	\$41.00
31-8062	2	6"	5¾"	\$34.85	\$36.90	\$41.00



## HALF-ROUND SLIM

Order #	Cut	Length	Cutting Length	12+	6+	1+
31-8064	0	6"	5¾"	\$36.00	\$38.12	\$42.35
31-8066	2	6"	5¾"	\$36.89	\$39.06	\$43.40



## BARRETTE

Order #	Cut	Length	Cutting Length	12+	6+	1+
31-8048	0	6"	5¾"	\$29.54	\$31.28	\$34.75
31-8050	2	6"	5¾"	\$29.54	\$31.28	\$34.75



## HAND

Order #	Cut	Length	Cutting Length	12+	6+	1+
31-8052	0	6"	5¾"	\$20.15	\$21.33	\$23.70
31-8054	2	6"	5¾"	\$20.15	\$21.33	\$23.70

## GROBET USA® PREMIUM NEEDLE FILES

Grobet USA® has the highest execution standard on files. The surface has a Rockwell hardness of 72HRC, the hardest steel known. These files will give a better performance on hard-to-file surfaces. They are resistant to corrosion—no need to grease these files—and have a longer life than the standard file. Excellent for use on platinum. Use 37-8794 file handle.

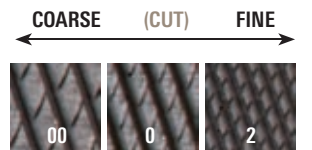

## BARRETTE

Order #	Cut	Length	Cutting Length	12+	6+	1+
31-8002	0	7"	3¼"	\$14.24	\$15.08	\$16.75
31-8004	2	7"	3¼"	\$14.24	\$15.08	\$16.75



## HALF-ROUND

Order #	Cut	Length	Cutting Length	12+	6+	1+
31-8014	0	7"	3¼"	\$16.11	\$17.06	\$18.95
31-8016	2	7"	3¼"	\$16.11	\$17.06	\$18.95



## EQUALLING

Order #	Cut	Length	Cutting Length	12+	6+	1+
31-8008	0	7"	3¼"	\$14.24	\$15.08	\$16.75
31-8010	2	7"	3¼"	\$14.24	\$15.08	\$16.75

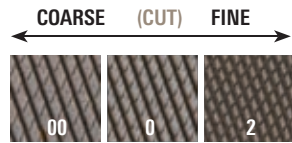

**GROBET USA® PREMIUM NEEDLE FILES**  
Made in Switzerland.



**SQUARE**

Order #	Cut	Length	Cutting Length	12+	6+	1+	Order #	Cut	Length	Cutting Length	12+	6+	1+
31-8032	0	7"	3/4"	\$13.39	\$14.18	\$15.75	31-8034	2	7"	3/4"	\$13.39	\$14.18	\$15.75



**THREE-SQUARE**

Order #	Cut	Length	Cutting Length	12+	6+	1+	Order #	Cut	Length	Cutting Length	12+	6+	1+
31-8026	0	7"	3/4"	\$13.39	\$14.18	\$15.75	31-8028	2	7"	3/4"	\$13.39	\$14.18	\$15.75



**ROUND**

Order #	Cut	Length	Cutting Length	12+	6+	1+	Order #	Cut	Length	Cutting Length	12+	6+	1+
31-8038	0	7"	3/4"	\$13.39	\$14.18	\$15.75	31-8040	2	7"	3/4"	\$13.39	\$14.18	\$15.75

**SIX YELLOW TANG FILES SET**

For platinum, stainless steel, and other hard-to-file materials, these files offer little to no clogging and are highly resistant to corrosion. Set includes one of each: barrette, equalling, half-round, three-square, square, and round.

Order #	Cut	Length	Cutting Length	12+	6+	1+
31-8044	0	7"	3/4"	\$41.61	\$44.06	\$48.95
31-8046	2	7"	3/4"	\$41.61	\$44.06	\$48.95

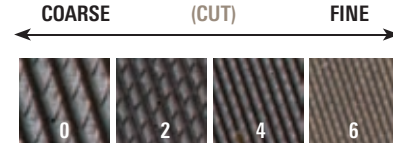

**ASSORTED NEEDLE FILES**

Sets consist of one each: barrette, crossing, equalling, half-round, joint round edge, knife, marking, round, splitting, square, 3-square, and warding files. Feature knurled handles.



Order #	Cut	Length	12+	6+	1+
31-2142	2	5 1/2"	\$89.34	\$94.59	\$105.10
31-2143	4	5 1/2"	\$95.58	\$101.21	\$112.45
31-2141	0	5 1/2"	\$89.34	\$94.59	\$105.10



**GROBET USA® NEEDLE FILES**

Use these precision files for exacting work. Made of the highest quality steel, they are machined and finished for precision shape and balance.



**EQUALLING**

Order #	Cut	Length	12+	6+	1+	Order #	Cut	Length	12+	6+	1+
31-5120	0	7 1/4"	\$8.88	\$9.41	\$10.45	31-5144	4	7 1/4"	\$8.88	\$9.41	\$10.45
31-5132	2	7 1/4"	\$8.88	\$9.41	\$10.45						



**HALF-ROUND**

Order #	Cut	Length	12+	6+	1+	Order #	Cut	Length	12+	6+	1+
31-5310	0	7 3/4"	\$11.01	\$11.66	\$12.95	31-5354	4	7 3/4"	\$11.86	\$12.56	\$13.95
31-5332	2	7 3/4"	\$11.01	\$11.66	\$12.95						



**THREE-SQUARE**

Order #	Cut	Length	12+	6+	1+	Order #	Cut	Length	12+	6+	1+
31-6450	0	7 3/4"	\$9.18	\$9.72	\$10.80	31-6494	4	7 3/4"	\$9.82	\$10.40	\$11.55
31-6472	2	7 3/4"	\$9.18	\$9.72	\$10.80	31-6506	6	7 3/4"	\$28.01	\$29.66	\$32.95

All items are priced at jeweler's cost, are sold each, unless otherwise noted, and are subject to change without notice. Visit [Stuller.com](http://Stuller.com) for our complete product selections, current pricing, and quantity price breaks. | 273





KNIFE

Order #	Cut	Length	12+	6+	1+	Order #	Cut	Length	12+	6+	1+
31-5630	0	7 3/4"	\$11.01	\$11.66	\$12.95	31-5642	2	7 3/4"	\$11.01	\$11.66	\$12.95



ROUND

Order #	Cut	Length	12+	6+	1+	Order #	Cut	Length	12+	6+	1+
31-5970	0	7 3/4"	\$8.46	\$8.96	\$9.95	31-5994	4	7 3/4"	\$9.31	\$9.86	\$10.95
31-5982	2	7 3/4"	\$8.46	\$8.96	\$9.95						



BARRETTE

Order #	Cut	Length	12+	6+	1+	Order #	Cut	Length	12+	6+	1+
31-4660	0	7 3/4"	\$9.78	\$10.35	\$11.50	31-4704	4	7 3/4"	\$10.16	\$10.76	\$11.95
31-4682	2	7 3/4"	\$9.78	\$10.35	\$11.50						



CROSSING

Order #	Cut	Length	12+	6+	1+	Order #	Cut	Length	12+	6+	1+
31-4940	0	7 3/4"	\$10.16	\$10.76	\$11.95	31-4964	4	7 3/4"	\$11.86	\$12.56	\$13.95
31-4952	2	7 3/4"	\$10.16	\$10.76	\$11.95						



EQUALLING

Order #	Cut	Length	12+	6+	1+	Order #	Cut	Length	12+	6+	1+
31-5051	00	6 1/4"	\$7.61	\$8.06	\$8.95	31-5104	4	6 1/4"	\$7.61	\$8.06	\$8.95
31-5060	0	6 1/4"	\$7.61	\$8.06	\$8.95	31-5116	6	6 1/4"	\$8.46	\$8.96	\$9.95
31-5082	2	6 1/4"	\$7.61	\$8.06	\$8.95						



HALF-ROUND

Order #	Cut	Length	12+	6+	1+	Order #	Cut	Length	12+	6+	1+
31-5241	00	6 1/4"	\$8.88	\$9.41	\$10.45	31-5294	4	6 1/4"	\$8.93	\$9.45	\$10.50
31-5250	0	6 1/4"	\$8.88	\$9.41	\$10.45	31-5306	6	6 1/4"	\$12.03	\$12.74	\$14.15
31-5272	2	6 1/4"	\$8.88	\$9.41	\$10.45						



GROBET USA® NEEDLE FILES

Genuine precision files from Grobet USA®.

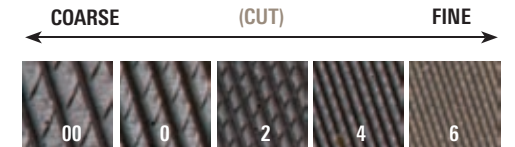

SQUARE

Order #	Cut	Length	12+	6+	1+	Order #	Cut	Length	12+	6+	1+
31-6191	00	6 1/4"	\$9.78	\$10.35	\$11.50	31-6244	4	6 1/4"	\$10.16	\$10.76	\$11.95
31-6200	0	6 1/4"	\$9.78	\$10.35	\$11.50	31-6256	6	6 1/4"	\$11.01	\$11.66	\$12.95
31-6222	2	6 1/4"	\$9.78	\$10.35	\$11.50						



THREE-SQUARE

Order #	Cut	Length	12+	6+	1+	Order #	Cut	Length	12+	6+	1+
31-6371	00	6 1/4"	\$7.61	\$8.06	\$8.95	31-6424	4	6 1/4"	\$8.46	\$8.96	\$9.95
31-6380	0	6 1/4"	\$7.61	\$8.06	\$8.95	31-6436	6	6 1/4"	\$10.16	\$10.76	\$11.95
31-6402	2	6 1/4"	\$7.61	\$8.06	\$8.95						



KNIFE

Order #	Cut	Length	12+	6+	1+	Order #	Cut	Length	12+	6+	1+
31-5580	0	6 1/4"	\$8.12	\$8.60	\$9.55	31-5614	4	6 1/4"	\$9.01	\$9.54	\$10.60
31-5592	2	6 1/4"	\$8.12	\$8.60	\$9.55	31-5626	6	6 1/4"	\$10.50	\$11.12	\$12.35



ROUND

Order #	Cut	Length	12+	6+	1+	Order #	Cut	Length	12+	6+	1+
31-5901	00	6 1/4"	\$7.14	\$7.56	\$8.40	31-5954	4	6 1/4"	\$7.74	\$8.19	\$9.10
31-5910	0	6 1/4"	\$7.14	\$7.56	\$8.40	31-5966	6	6 1/4"	\$8.16	\$8.64	\$9.60
31-5932	2	6 1/4"	\$7.14	\$7.56	\$8.40						

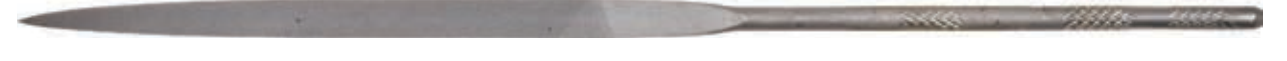

BARRETTE

Order #	Cut	Length	12+	6+	1+	Order #	Cut	Length	12+	6+	1+
31-4581	00	6 1/4"	\$7.14	\$7.56	\$8.40	31-4634	4	6 1/4"	\$7.10	\$7.52	\$8.35
31-4590	0	6 1/4"	\$7.14	\$7.56	\$8.40	31-4646	6	6 1/4"	\$10.97	\$11.61	\$12.90
31-4612	2	6 1/4"	\$7.14	\$7.56	\$8.40						



CROSSING

Order #	Cut	Length	12+	6+	1+	Order #	Cut	Length	12+	6+	1+
31-4900	0	6 1/4"	\$8.88	\$9.41	\$10.45	31-4924	4	6 1/4"	\$8.88	\$9.41	\$10.45
31-4912	2	6 1/4"	\$8.88	\$9.41	\$10.45	31-4936	6	6 1/4"	\$10.50	\$11.12	\$12.35



**GROBET USA® ESCAPEMENT FILES**

Genuine precision files, from Grobet USA feature square handles.

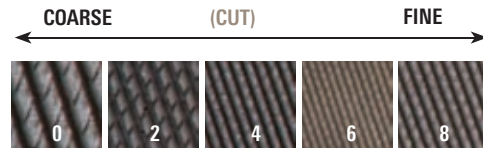

**BARRETTE**

Order #	Cut	Length	12+	6+	1+	Order #	Cut	Length	12+	6+	1+
31-7000	0	5½"	\$13.35	\$14.13	\$15.70	31-7046	6	5½"	\$15.13	\$16.02	\$17.80
31-7012	2	5½"	\$13.35	\$14.13	\$15.70	31-7050	8	5½"	\$15.43	\$16.34	\$18.15
31-7034	4	5½"	\$14.37	\$15.21	\$16.90						



**CROSSING**

Order #	Cut	Length	12+	6+	1+	Order #	Cut	Length	12+	6+	1+
31-7142	2	5½"	\$14.37	\$15.21	\$16.90	31-7166	6	5½"	\$16.28	\$17.24	\$19.15
31-7154	4	5½"	\$16.45	\$17.42	\$19.35						



**EQUALLING**

Order #	Cut	Length	12+	6+	1+	Order #	Cut	Length	12+	6+	1+
31-7202	2	5½"	\$12.33	\$13.05	\$14.50	31-7214	4	5½"	\$12.92	\$13.68	\$15.20



**HALF-ROUND**

Order #	Cut	Length	12+	6+	1+	Order #	Cut	Length	12+	6+	1+
31-7252	2	5½"	\$14.41	\$15.26	\$16.95	31-7286	6	5½"	\$15.43	\$16.34	\$18.15
31-7274	4	5½"	\$14.62	\$15.48	\$17.20	31-7290	8	5½"	\$17.81	\$18.86	\$20.95



**ROUND**

Order #	Cut	Length	12+	6+	1+	Order #	Cut	Length	12+	6+	1+
31-7420	00	5½"	\$12.07	\$12.78	\$14.20	31-7466	6	5½"	\$12.33	\$13.05	\$14.50
31-7432	2	5½"	\$12.07	\$12.78	\$14.20	31-7470	8	5½"	\$14.15	\$14.99	\$16.65
31-7454	4	5½"	\$12.33	\$13.05	\$14.50						



**THREE-SQUARE**

Order #	Cut	Length	12+	6+	1+	Order #	Cut	Length	12+	6+	1+
31-7612	2	5½"	\$13.35	\$14.13	\$15.70	31-7636	6	5½"	\$15.34	\$16.25	\$18.05
31-7624	4	5½"	\$14.15	\$14.99	\$16.65						



**KNIFE**

Order #	Cut	Length	12+	6+	1+
31-7336	6	5½"	\$18.53	\$19.62	\$21.80



**THREE-SQUARE**

Order #	Cut	Length	12+	6+	1+	Order #	Cut	Length	12+	6+	1+
31-7627	4	5½"	\$14.03	\$14.85	\$16.50	31-7629	8	5½"	\$16.28	\$17.24	\$19.15
31-7576	6	5½"	\$18.53	\$19.62	\$21.80	31-7626	2	5½"	\$13.09	\$13.86	\$15.40

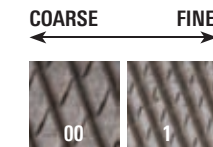

**HABILIS FILE SET**

Habilis files are the in-between files, perfect for those jobs too large for the needle but too small for the regular file. These come with a built-in handle and are excellent for shaping. Sold in sets of 5.

Item	Order #	Cut	Length	12+	6+	1+
A	33-8301	00	8½"	\$65.37	\$69.21	\$76.90
B	33-8302	1	8½"	\$59.63	\$63.14	\$70.15



**NEEDLE FILE SET**

Contains one of each: barrette, crossing, equalling, half-round, round-edge, joint, knife, marking, round, slitting, square, three-square, and warding. All have knurled handles.



Order #	Cut	Length	12+	6+	1+
31-6802	2	6¼"	\$87.76	\$92.93	\$103.25
31-6814	4	6¼"	\$87.72	\$92.88	\$103.20
31-6828	6	6¼"	\$109.78	\$116.24	\$129.15
31-6790	0	6¼"	\$81.94	\$86.76	\$96.40





**ECONOMY NEEDLE FILE SET**

May vary on individual file shapes and sizes.

12

Order #	Cut	Length	12+	6+	1+
31-6840	2	5½"	\$8.42	\$8.91	\$9.90

**MINI-NEEDLE FILE SET**

Mini economy needle files to get into tight spots and tiny settings. Set may vary on individual shapes and sizes. Use with 37-8790 handle.

12

Order #	Cut	Length	12+	6+	1+
31-6852	2	4"	\$8.80	\$9.32	\$10.35

**MASCOT® UTILITY FILE SET**

Set consists of one of each of six American pattern file shapes: square, half-round, triangular, round, flat, and warding. Wooden file handle is treated with a smooth lacquer.

6

Order #	Length	Blade Length	12+	6+	1+
33-9235	7"	4"	\$9.99	\$10.58	\$11.75

**BROACHES SET**

This set of six broaches features plastic handles. Sizes included numbers 46 through 72 according to English Stubs Gauge. Five-sided with a regular taper and perfect finish. These are used for general purpose work such as cutting, cleaning, and finishing. Made in Germany.

6

Order #	Stub Range	12+	6+	1+
15-5060	43–72	\$13.09	\$13.86	\$15.40

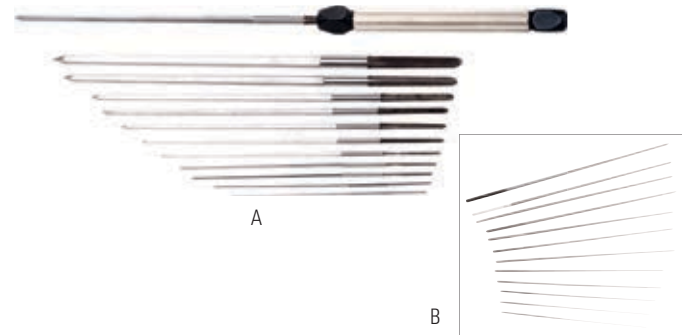
**ASSORTED BROACH CUTTING SETS**

This pen-sized aluminum holder/handle with ⅜" diameter anodized barrel and pocket clip holds 5½" diamond needle files with shortened shanks that are stored in the barrel. Handle has non-slip finger grip surface for positive control and is a convenient way to keep files at your fingertips. Round broach set is best used for general purpose work.

12

Item	Order #	Style	Stub Range	12+	6+	1+
A	15-5050	Cutting	15–70	\$35.11	\$37.17	\$41.30
B	15-5055	Round	55–80	\$29.58	\$31.32	\$34.80

**DOUBLE-ENDED RIFFLER FILE SET**

Six-inch long, double-ended, riffler files are shipped in a vinyl pouch for convenience. Note: Use proper eye protection.

10

Order #	Length	12+	6+	1+
31-9910	6"	\$13.22	\$14.00	\$15.55

**DIAMOND NEEDLE FILE SET**

These files are made of fine steel with a diamond coating and used for precision filing jobs. The diamond particles are electroplated onto the surface of the metal.

5

Order #	Description	Length	12+	6+	1+
33-9500	Medium Grit Needle File Set	5½"	\$36.55	\$38.70	\$43.00

**INDIVIDUAL FILES**

Order #	Description	Length	12+	6+	1+
33-9501	Equalling	5½"	\$9.27	\$9.81	\$10.91
33-9502	Three-Square	5½"	\$9.27	\$9.81	\$10.90
33-9503	Half-Round	5½"	\$9.27	\$9.81	\$10.90

**SWISS NEEDLE FILE SET**

This needle file set is made of chrome alloy steel. Set includes barrette, equalling, half-round, round, square, three-square.

Order #	Cut	Length	12+	6+	1+
31-6833	2	5½"	\$25.54	\$27.05	\$30.05

**GROBET USA® NEEDLE FILE SET**

Grobet USA Swiss-pattern needle files are precision files designed for exacting work. Made with high-quality steel with strict tolerances for size, uniform cut, and hardness, these files feature round, knurled handles to aid gripping. Mold makers, goldsmiths, gunsmiths, and musical instrument manufacturers use these for precise finishing on small surfaces.

Order #	Cut	Length	1+
31-7715	4"	2½"	\$50.95

**FILE HANDLES**

Item	Order #	Description	12+	6+	1+
A	37-7856	Skroo-Zon Wooden Handle (6" Files Only)	\$2.64	\$2.79	\$3.10
B	37-7846	Threaded Plastic File Handle	\$3.15	\$3.33	\$3.70

**NEEDLE FILE HANDLES**

Item	Order #	Description	12+	6+	1+
C	37-8336	Hardwood for Metal Ferrule 4" x ⅝"	\$0.94	\$0.99	\$1.10
D	37-8330	Hardwood for Metal Ferrule 4" x ⅜"	\$0.94	\$0.99	\$1.10

**ALUMINUM FILE HANDLES**

These needle file handles are an entirely different approach to file handles. Handles are made of high-grade, anodized aluminum with steel chucks and are knurled for ease of handling. The steel chucks are fixed into the shaft. When the knurled sleeve is unscrewed, the chuck will quickly release the file. This handle could possibly be the needle file handle to last a lifetime. These handles have been tested and found superior to all other handles.

Item	Order #	Needle File	Length	Diameter	12+	6+	1+
E	37-8790	4"	4½"	⅜"	\$7.27	\$7.70	\$8.55
F	37-8792	5½" - 6¼"	4½"	½"	\$7.99	\$8.46	\$9.40
G	37-8794	6¼" - 7¼"	4½"	½"	\$8.12	\$8.60	\$9.55





# FLEX SHAFTS AND MICROMOTORS



## NSK MICROMOTOR

With a wide variety of excellent capabilities, the NSK micromotor offers both balance and motor power for smooth speeds and handling.

Advanced Features include-

Advanced Control Function

- Upgraded Digital Display. EVOLUTION Speed Control with Flash Load Indicator.

Advanced User Friendly Design

- New Industrial Design. EVOLUTION New user friendly case meets design and performance requirements.

Diversity for Work Efficiency

- Two Motors A and B can be connected to cover multiple work requirements.

Memory Speed Function FiXpeed

- An exclusive new feature of the Emax EVOLUTION is the FiXpeed system allowing independent foot switch operation for the A and B Motors. "A" Motor foot switch can be on/off and "B" Motor foot switch can be variable speed. This function brings unprecedented versatility and workability.

Item	Order #	Description	1+
A	35-1237	NSK Micromotor	\$1,350.00



## MICRO-NX MICRO MOTOR

MicroNX specializes in manufacturing micromotor handpieces. With products exported to 25 countries around the world, they are the leader in micromotor handpiece technology. MicroNX provides the highest quality micromotor handpieces in various models and specifications.

Item	Order #	Description	1+
B	34-6105	300S Micromotor	\$495.00
C	34-6105	303B Micromotor	\$235.00



## FOREDOM

### PORTABLE MICROMOTOR

Micromotor with pocket size control unit has built-in lithium-ion rechargeable battery for the ultimate in portability. Variable speed up to 30,000 RPM.

Item	Order #	Description	12+	6+	1+
D	34-6100	Portable Rotary Micromotor Kit	\$339.15	\$359.10	\$399.00
E	34-6100	Foot Pedal	\$22.10	\$23.40	\$26.00

## FOREDOM® K.1070 MICROMOTOR KITS

Ideal for high-speed applications up to 38 000 RPM including light deburring of cast pieces bright cutting in jewelry making and fine detailing.

A. K.1070

Rotary Kit Includes-

- Control-HP4
- Handpiece with 2.35mm (3X32") collet -MH-170
- Variable speed foot control-HP4-960
- Handpiece cradle-HP4-933
- Extra pair of motor brushes, spare fuses, and collet changing wrenches

B. K.1020

High Torque Kit includes-

- 20,000 RPM max speed - High torque 60/50 Hz 4.82 Amps DC
- Switch for either 110/120 or 220/240 voltage
- Dial control and foot control for variable speed
- Forward or reverse rotation - Built-in overload protection
- CE compliant.

One-year Limited Warranty Kit Includes: control unit, handpiece, variable speed foot control, handpiece cradle, chuck key with handle, and extra set of motor brushes.

C. H.MH-120

High Torque Chuck-Style Handpiece features extra power and a geared three-jaw #0 chuck that takes any size rotary accessory or drill bit with shanks up to 5/32" (4mm) diameter. CE compliant. Comes supplied in Kit K.1020 and works with the same HP4-917 Control Unit that comes with Micromotor Kits K.1070 K.1080 and K.1090.

D. H.MH-170

High Speed Rotary Handpiece has a slender, contoured grip for precise and very high speed work up to 38,000 rpm. It has a fan cooled, brush-type continuous duty motor that runs cool and vibration free with permanently lubricated, shielded ball bearings that require no lubrication.

Item	Order #	Description	1+
A	34-6115	K.1070 Rotary Micromotor Kit	\$365.00
B	34-6114	K.1020 High Torque Kit	\$499.00
C	34-6113	High Torque Chuck Style Handpiece	\$338.00
D	34-6117	High Speed Rotary Handpiece	\$230.00

## FOREDOM® 1050 BRUSHLESS MICROMOTOR KIT

The 1050 Micromotor features high torque throughout the speed range of 1,000 to 50,000 RPM. High speed provides smooth, clean, and sharp detailing in metal. It's also great for bright cutting, grinding, finishing, texturing, and polishing. Low speed offers extra control and power for stone setting and milling.

Item	Order #	Description	1+
E	34-6116	MicroMotor Kit	\$899.00





**FOREDOM**



18,000 RPM

**FOREDOM® 2220 JEWELER'S KIT**

The 1/6 HP reversible SR Motor with FCT foot-operated speed control, H.20 Hand piece, and 43-piece accessory kit offers superior performance and combines all of the features expected. H.20 Handpiece comes with a 1.5mm allen wrench to adjust collet tension. SR Motor operates in both forward and reverse rotation and comes with a standard 39" inner and outer sheath and shaft.

Item	Order #	Description	1+
A	34-2242	SR Motor with H.20 Handpiece	\$359.00
B	34-2375	H.20 Handpiece	\$91.99
C	34-2157	Motor Maintenance Kit 10	\$18.00

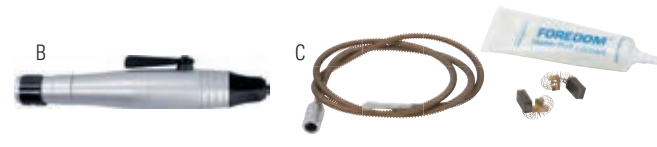

**FOREDOM® 2230 JEWELER'S KIT**

The 1/6 HP reversible SR Motor with FCT foot-operated speed control, H.30 Handpiece with chuck key, and accessory kit offers superior performance and combines all of the features expected. Operates in both forward and reverse rotation.

Item	Order #	Description	1+
D	34-2243	SR Motor with H.30 Handpiece	\$338.00
E	34-2215	H.30 Silver	\$70.00
F	34-2158	Motor Maintenance Kit 8	\$18.00

18,000 RPM



**FOREDOM® TX300 JEWELER'S KIT**

The TX permanent-magnet DC 1/8 HP motor delivers more torque and complete control than any other flexible shaft power tool. The TX has more torque in the low, medium, and full-speed ranges than standard motors. It offers smooth and controlled acceleration. Ideal for stone setting, wax carving, and high-speed polishing.

**Kit Includes —**

- TX Permanent-Magnet Motor, 1/8 HP
- H.30 Handpiece with chuck key
- TXR Foot-Operated Speed Control
- 43-piece accessory kit

15,000 RPM

Item	Order #	Description	1+
G	34-2255	TX300 Motor with H.30 Handpiece	\$415.99
H	34-2215	H.30 Silver	\$70.00

**ACCESSORIES**

J	34-2286	TXR Foot Control	\$56.99
K	34-2156	Maintenance Kit 16	\$22.00



**FOREDOM® STONE SETTING KIT**

This high-torque/low-speed motor and Quick Change handpiece combination Will make this an ideal kit for stone setting, drilling, and other low-speed applications.

**Kit includes —**

- LX Permanent-Magnet Motor high-torque/low-speed, 5,000 RPM
- H.18 Quick Change Handpiece
- TXR Foot-Operated Speed Control
- Accessory kit tray

Item	Order #	Description	1+
A	34-2240	LX Stone Setting Kit	\$450.99

**ACCESSORIES**

B	34-2213	H.18 Handpiece	\$150.00
C	34-2156	Maintenance Kit 16	\$22.00



**FOREDOM® POWERGRAVER KIT WITH SETTING ACCESSORIES**

Ideal for bead, prong, channel, hammer, and bezel setting as well as engraving and other decorative work. The PowerGraver provides a power assist to stone setting and engraving operations. The 2293 PowerGraver kit is a dedicated system with specialized components. Its new permanent magnet Series PGX (formerly PG) motor is designed for high torque-low speed applications with permanently lubricated ball bearings for quiet, trouble-free performance. The 9D handpiece works and feels like a hand engraving tool with the advantages of greater control and the ability to adjust the impact force. The unit comes equipped with a special, extra flexible neoprene sheath and a 6' long power cord. A DVD with 32 minutes of instruction for using the PowerGraver is included, along with a set of accessories and maintenance items. Two-year warranty of PowerGraver Motor. Accessories included in kit: carbide stylus, anvil point, and a set of four gravers (#52 round, #3 onglette, #2 bevel, and #40 flat).

Item	Order #	Description	1+
D	34-2293	PowerGraver 2293 Kit	\$565.99

**ACCESSORIES**

E	34-2131	Carbide Stylus Point	\$38.00
F	34-2130	Anvil Point	\$6.00

**FOREDOM® H 9D HANDPIECE**

This special chuck-type handpiece fits only the PowerGraver. Adjusting ring changes impact force and included palm rest provides comfort and feel of hand engraving tool. Comes with three interchangeable collets (1/16" 3/32" 1/8").

Item	Order #	Description	1+
G	34-2294	H 9D Handpiece	\$196.99

**FOREDOM® MOTORS**

All motors come with a 39" long shaft in a protective sheath with a steel liner and silencer. The TX motor requires a special, speed control that cannot be used on other models. Comes with sheath. One-year warranty. Permanent-magnet motor for full range of use. Requires TXR Foot Control.

Item	Order #	Description	HP	RPM	1+
H	34-2257	TX Motor	1/8	15,000	\$265.00
J	34-2241	SR Motor	1/6	18,000	\$215.00

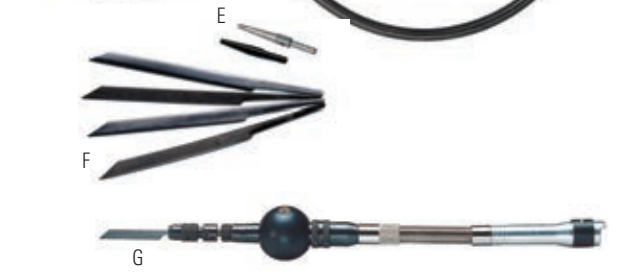

15,000 RPM

18,000 RPM



Flex Shafts and Micromotors

Flex Shafts and Micromotors



**FOREDOM**



**FOREDOM® HAMMER STONE SETTING KIT**

This high-torque/low-speed motor and Quick Change handpiece combination make this an ideal kit for stone setting, drilling, and other low-speed applications.

**Kit Includes —**

- LX Permanent-Magnet Motor, high-torque/low-speed, 5,000 RPM
- H15 Hammer Quick Change Handpiece with anvil point, pavé point, and carbide styles
- TXR Foot Speed Control
- Tray

Item	Order #	Description	Style	1+
A	34-2250	Stone Setting Kit		\$430.00
TIPS				
B	34-2130	Anvil Point	Flat	\$6.00
C	34-2131	Carbide Stylus Point	Point	\$38.00
D	34-2132	Pavé	Pavé Point	\$42.22

**FOREDOM® H.15 AND H.15D HANDPIECES**

Hammer handpiece used by professional jewelers for stone setting and decorative work. Has 1/32" stroke with adjustable impact and comes with an anvil point (34-2130). Can also be used with pavé point (34-2132) for special texturing. A stylus (34-2131) with pointed, carbide tip is available for texturing, marking, or scribing hardened steel. Recommended for use with LX Motor at speeds of 0-5,000 RPM. 1/2" diameter at tip, 6" long, and 4 oz.

Item	Order #	Description	Style	1+
E	34-2211	H.15 Handpiece		\$144.00
F	34-2212	H.15D Handpiece		\$169.00
TIPS				
G	53-1905	Diamond Point	Texturing	\$37.10
H	34-2130	Anvil Point	Flat	\$6.00
J	34-2131	Carbide Stylus Point	Point	\$38.00
K	34-2132	Pavé	Pavé Point	\$42.22

**GROBET USA® S-300 MOTOR**

L. Versatile flex shaft machine with ball bearing motor runs smooth and requires no lubrication. One-year replacement warranty. Includes S-300 motor, foot pedal, and No. 30 handpiece.

M. Includes S-300 motor with quick change handpiece kit.

N. Includes C-300 motor with quick change handpiece kit.

**FLEX SHAFT MAINTENANCE KIT**

Includes tube of flexible shaft lubricant (grease) and a set of replacement motor brushes.



Item	Order #	Description	HP	1+
L	34-2325	S-300 Motor with #30 Handpiece	1/8	\$119.00
M	34-2319	S-300 1/8 HP	1/8	\$109.95
N	34-2327	C-300 1/10 HP	1/10	\$89.00
P	34-2251	Maintenance Kit		\$17.15
ACCESSORIES				
Q	34-2346	Inner Shaft		\$8.25
R	34-2347	Outer Shaft		\$9.30



**FOREDOM® MAINTENANCE KITS AND SUPPLIES**

A. **Motor Maintenance Kits.** Your flex shaft will likely require replacement shafts and sheaths during its lifetime. Motor specific kits come packed with a shaft, motor brushes, and grease.

B. **Motor Brushes.** Motor brushes come in pairs and should be replaced for optimal machine performance when worn to 1/4 inch in length. Be sure to watch our video for help with replacing motor brushes.

C. **Shafts and Sheaths.** You can expect to replace inner shafts and outer sheaths over the course of your machine's life. There are various types for different machines.

D. **Speed Controls.** Speed controls are required to operate a Foredom flexible shaft machine and allow the user to vary speed from low to full. Motors connect to speed controls and not directly into an electrical outlet. The 6' long speed control power cord plugs into an outlet.



**LUBRICANTS**

Item	Order #	Description	Size	1+
E	34-2260	Flexible Shaft Grease	1 oz	\$3.50
F	34-2279	Hypodermic Oiler		\$4.50

**DUPLEX SPRING**

Item	Order #	Description	1+
G	34-2307	Spring for Duplex	\$12.50

Order #	Description	1+	CC	CC	DD	EE	GG	H	HB	K	L	LB	MM	MMG	PG	R	RB	S	SB	SM	SR	SRB	SRM	TX	TXB	TXGH	TXH	TXM	TXMH	
34-2158	A. Motor Maintenance Kit 8	\$18.00																	•	•	•	•	•							
34-2159	Maintenance Kit 9	\$18.00	•		•								•																	
34-2157	Motor Maintenance Kit 10	\$18.00																				•								
34-2156	Maintenance Kit 16	\$22.00									•														•					
34-2261	B. Motor brushes	\$9.00	•		•	•							•								•									
34-2262	Motor brushes	\$11.00			•	•	•																							
34-2263	Motor brushes	\$12.00				•																								
34-2254	Motor brushes	\$9.00																												
34-2270	C. Inner shaft	\$11.00	•			•	•	•				•	•																	
34-2274	Inner shaft	\$11.00				•	•						•																	
34-2277	Standard sheath	\$15.00				•	•																							
34-2271	Standard sheath	\$15.00	•			•	•	•				•	•																	
34-2273	Neoprene sheath	\$28.00	•			•	•	•				•	•																	
34-2297	60 in. HD sheath	\$70.00																												
34-2308	Connector CC-DD	\$3.50	•																											
34-2309	Connector EE-GG	\$3.50				•	•																							
34-2280	D. FCT Foot control	\$36.99	•									•																		
34-2286	TXR Foot Control	\$56.99																												
34-2281	SCT Foot control	\$71.99	•									•																		
34-2289	SXR Foot control	\$88.00	•									•																		
34-2283	EM Manual control	\$85.00	•									•																		
34-2295	EMX Manual control	\$88.00																												



**FOREDOM® WORKBENCH SYSTEM**

Create your own custom bench system with Foredom®. Combine the Foredom flex shaft hanger with an innovative LED light bar and your choice of four different tool arms. This stainless steel system places everything within reach without cluttering your benchtop.

Everything is sold separately to allow a truly customizable experience. Purchase only what you need to make your bench a perfect place for you. The LED light bar swings up into a vertical position automatically turning off and getting out of your way when it isn't needed.

The four unique tool arms help to organize your bench in the best possible way. Choose from the bur holder arm, magnetic tool arm, cup holder arm, and tray arm to achieve a clean, clutter-free work place.

**FOREDOM**



**FOREDOM® WORKBENCH SYSTEM**

Order # 34-10100

Item	Description	1+
A	Support Rod 25¼"	\$42.33
	Support Rod 17¾"	\$39.00
B	Motor Hanger Only	\$59.00
C	LED Light Bar	\$139.00
D	Bur Holder Arm	\$69.00
E	Cup Holder Arm	\$55.55
F	Magnetic Tool Arm	\$109.00
G	Accessory Tray Arm	\$59.00
H	Peg Arm	\$69.00
J	Multi Handpiece Arm	\$75.00
K	Dual Handpiece Rest	\$29.00
	Motor Hanger with LED Light Bar	\$189.00

**REPLACEMENT PARTS**

L	40ml Plastic Jars with Tops (Pack of 6)	\$9.00
M	Base Mounting Plate	\$17.00
	4mm Head Hex Screw	\$0.50
	Adapter Plug	\$39.00
	Light Connector Cord Set	\$6.00
	Light Shade	\$7.00
	Micro Switch	\$1.50
	LED Light Strip	\$59.00
	Light Shade	\$11.20
	Hanger Hook with Spring	\$4.80



**FLEX SHAFT DOUBLE MOTOR HANGERS**

Convenient stand holds or hangs up machines. It attaches to workbench, allowing more working space. Both models include a handpiece rest and t-rod, which can accommodate two motors. Full swivel with locking screw.

Item	Order #	Description	1+
A	34-2267	Handpiece Rest	9.00

**HANDPIECE HOLDER**

Convert your flex shaft machine into a polishing lathe. A convenient way to hold your handpiece while polishing, grinding, sanding, and carving. The handpiece holder comes complete with a handpiece clamp, rod, and bench clamp. Adjustable height up to 10". The bench clamp adjusts to bench top thicknesses up to 2¼". Fits handpieces No. 30, No. 304, No. 44, No. 44T, and No. 44HT.

Item	Order #	Description	1+
D	34-2268	Handpiece Holder	\$41.00

**PLASTIC CHUCK KEY HANDLE**

For No. 30, No. 30SJ, No. 25C, and No. 30H handpiece users.

Item	Order #	Description	12+	6+	1+
E	28-2114	Plastic Chuck Key with Handle	\$5.19	\$5.49	\$6.00

**FOREDOM® CUSHION HANDLE**

This foam, hand-fitted cushion fits nicely on the No. 30 and No. 44 Foredom handpieces. Makes those long hours of drilling go by quickly.

Order #	Description	1+
34-2266	Cushion Handle	\$2.00



**MOTOR HANGERS**

Convenient stand used to hold or hang up machines. Attaches to workbench, allowing more working space. Both models include a handpiece rest and t-rod, which can accommodate two motors. Full swivel with locking screw.

Item	Order #	Description	1+
B	34-6110	Adjustable Flex Shaft Holder	\$30.15
C	34-6112	Double Flex Shaft Holder	\$32.00

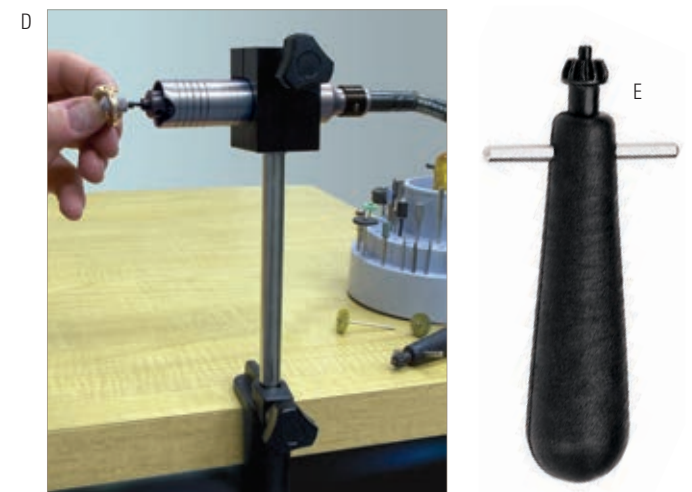



**FOREDOM**

**FOREDOM® H.30 AND H.30H HANDPIECES**

Excellent in quality and popular for its general purpose use, these handpieces feature three-jaw Jacob® style chuck that fits shanks from 0" to 5/32". Pre-lubricated ball bearings require no maintenance. H.30H This heavy-duty handpiece is designed for use with the Foredom H Flex Shaft system. Chuck key included with all models.

Item	Order #	Description	1+
A	34-2220	H.30H Handpiece	\$75.00
B	34-2215	H.30 Silver	\$70.00
C	34-2215	H.30 Blue	\$59.50
D	34-2215	H.30 Pink	\$70.00



**PLASTIC CHUCK KEY HANDLE**

For No. 30, No. 30SJ, No. 25C, and No. 30H handpiece users.

Item	Order #	Description	1+
E	28-2114	Plastic Chuck Key with Handle	\$6.00

**FOREDOM**



**FOREDOM® H.20 AND H.20D HANDPIECES**

The H.20 handpiece has a plastic molded front grip with tapered sides for easy handling. It has pre-lubricated ball bearings that do not require maintenance. A lever action handle is all that is required to change accessories. For use with 3/32" (2.35mm) shank burs.

Item	Order #	Description	1+
F	34-2375	H.20 Handpiece	\$91.99
G	34-2376	H.20D Handpiece	\$116.99
H	34-2377	Collet	\$10.50



**QUICK-CHANGE HANDPIECE**

Ergonomic design provides improved control and extra comfort. Release lever for use with 3/32" (2.4mm) shanks.

Item	Order #	Description	1+
J	34-2402	Quick Change Handpiece	\$65.60



**GROBET USA® QUICK-CHANGE HANDPIECE**

Special design provides better control and extra comfort. Quick-change lever for use with 3/32" shank.

Item	Order #	Description	1+
K	34-2354	Handpiece	\$144.60
L	34-2355	Handpiece with Duplex Spring	\$224.55

**FOREDOM**

**FOREDOM® H.52 AND H.52D QUICK-CHANGE ACCESSORIES**

Replacement accessories for Foredom® H.52 and H.52D quick-change handpieces.

Item	Order #	Description	1+
A	34-2364	Collet	\$24.35
B	34-2175	Replacement Ball	\$1.00



**FOREDOM® STONE SETTING KIT**

Handpiece with exclusive quick-change press-to-release collet. Ideal for stone setting and other applications requiring frequent bur changes. Slimmer grip for fingertip control. Accepts 3/32" (2.35mm) shank accessories. Pre-lubricated ball bearings require no maintenance.

Item	Order #	Description	1+
C	34-2213	H.18 Handpiece	\$150.00
D	34-2214	H.18D Handpiece	\$175.00
E	34-2310	Collet	\$28.00



**FOREDOM® H.10 AND H.10D HANDPIECES**

Quick release lever action for rapid accessory changes. Pre-lubricated ball bearings require no maintenance. Accepts 3/32" (2.35mm) shank.

Item	Order #	Description	1+
F	34-2209	H.10 Handpiece	\$279.00
G	34-2210	H.10D Handpiece	\$304.00
H	34-2219	Collet	\$56.50
J	34-4006	Duplex Axle	\$4.50
K	34-4007	Duplex Cover	\$16.50
L	34-4003	Clip Ring	\$2.00

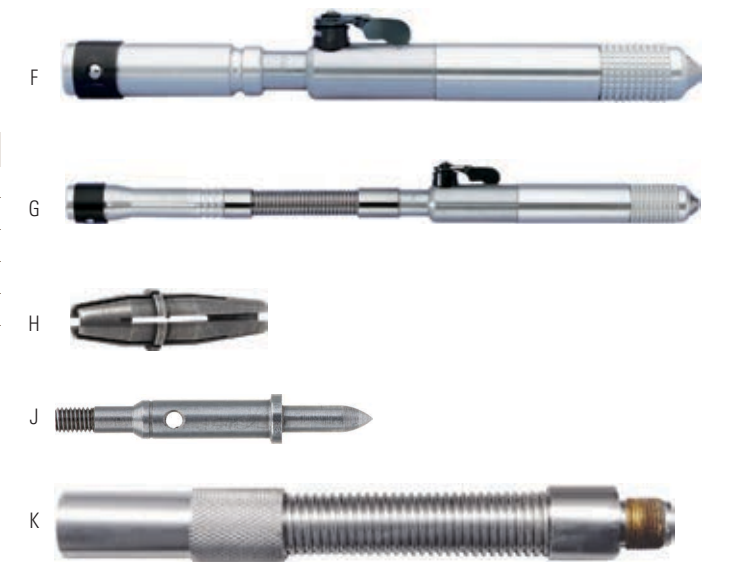



**FOREDOM**

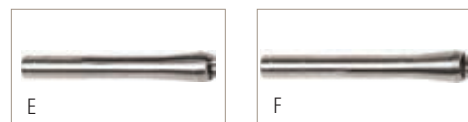

**FOREDOM® H.8 AND H.8D HANDPIECES**

Handpiece is anodized aluminum with tapered grip only 1/2" thick for comfortable fingertip control. Included are both 3/32" and 1/8" collets. Pin wrench also included. Permanently sealed, maintenance-free ball bearings make this an excellent alternative for continuous use.

Item	Order #	Description	Size	1+
A	34-2207	H.8 Handpiece		\$79.00
B	34-2208	H.8D Handpiece		\$110.00

**REPLACEMENT PARTS**

C	34-2100	Collet Set of 4 (34-2101 to 34-2104)		\$35.00
	34-2103	Collet	3/32"	\$8.50

**SWISS TECHNIQUE HANDPIECE**

Ideal for fast precision work that requires quick tool changes. The quick release collet can be opened even while the tool is spinning. Comes with a 3/32" collet. Shaped for the hand, vibration free, and has an all-metal dust-proof casing. Made in Switzerland.

Item	Order #	Description	Size	1+
D	34-2299	Rotary Handpiece		\$210.00
E	34-2303	Collet (replacement part)	3/32"	\$35.35
F	34-2304	Collet (replacement part)	1/8"	\$35.35

**FOREDOM® H.28 SLIM GRIP COLLET HANDPIECE**

Handpiece is anodized aluminum with tapered grip only 1/2" thick for comfortable fingertip control. Included are both 3/32" and 1/8" collets. Pin wrench also included. Permanently sealed, maintenance-free ball bearings make this an excellent alternative for continuous use.

Item	Order #	Description	1+
G	34-2370	H.28 Handpiece	\$65.99
H	34-2100	Collet Set of 4 (34-2101 to 34-2104)	\$35.00

**FOREDOM® H.44T AND H.44HT HANDPIECES**

Tapered-grip handpieces with a collet-type chuck that adapts to accessories up to 1/4". Pre-lubricated ball bearings require no maintenance. H.44T includes a pin, wrench, and three collets (3/32", 1/8", and 1/4"). H.44HT includes a pin, wrench, and two collets (1/8" and 1/4"). Designed for use with the Foredom® H Flex Shaft system. Use With TX Motors.

Item	Order #	Description	1+
J	34-2217	H.44T Handpiece	\$65.99

**Order # 34-21100**

Item	Description	ID	1+
K	Collet Set of 7 (41-444 to 447-449)	Assorted	\$60.00
L	Collet	3/32"	\$8.50
M	Collet	1/8"	\$8.50
N	Collet	5/32"	\$8.50

**BADECO® SWISS HANDPIECE**

Top-quality high-precision handpieces designed for rugged use. Made in Switzerland. Badeco hammer handpiece-

- Adjustable striking force
- Robust and handy
- 3,000 strokes per minute
- Comes with 3/32" collet

Item	Order #	Description	1+
P	34-2190	Hammer HP with Spring	\$375.00

**SWISS HAMMER HANDPIECE**

Lightweight slender aluminum body with a hardened steel inside mechanism. Comes with one screw-in cylinder non-hardened point.

Item	Order #	Description	Style	1+
A	34-2298	Hammer Handpiece		\$225.00
<b>TIPS</b>				
B	53-1905	Diamond Point	Texturing	\$37.10
C	34-2130	Anvil Point	Flat	\$6.00
D	34-2131	Carbide Stylus Point	Point	\$38.00
E	34-2132	Pavé	Pavé Point	\$42.22



**GROBET USA® HAMMER-STYLE HANDPIECE**

Designed to hit hard under control without excessive heat build-up.

Item	Order #	Description	1+
F	34-2351	Hammer HP	\$182.00
G	34-2352	Hammer HP with Duplex Spring	\$223.55
H	34-2353	Hammer Style	\$9.95
J	34-2359	Hammer Point	\$45.45



**AIR FILTER/OIL REMOVAL KIT**

A must for GRS® equipment when using an oil lubricated compressor. Removes dirt and oil contamination from compressed air.

Item	Order #	Description	1+
K	14-5004	Air Filter/Oil Removal Kit	\$107.05



**QUICK DISCONNECT KIT**

Saves time by letting you switch from one GRS® Handpiece to another in seconds. Includes main body and two handpiece connectors.

Item	Order #	Description	1+
L	14-5005	Quick Disconnect Kit	\$32.10

**CHICAGO PNEUMATIC AIR SCRIBE**

Lightweight air scribe that is ideal for engraving, texturing, or deburring. Capable of marking material as hard as RC-64. Accurate throttle selection can be made by adjusting the sleeve valve. Operates on less than 1 CFM. Requires an air compressor and filter/regulator (which are not included). Comes with stylus and 8 feet of reinforced hose. Foot pedal sold separately.

Item	Order #	Description	1+
M	26-4055	Pneumatic Air Scribe	\$435.45
N	26-4057	Foot Pedal	\$39.06



Flex Shafts and Micromotors

Flex Shafts and Micromotors



**WOLF BELT SANDER SET**

The Belt sander is convenient, compact, and connects to a flex shaft for power. It can be clamped directly on to the bench or mounted with an adaptor into a GRS® BenchMate® for greater support. Included is an attachment for hooking up to a dust collection system and five assorted Ruby belts.

Item	Order #	Description	Grit	1+
A	21-0491	Belt Sander with Assorted Ruby Belts		\$189.00
B	21-0492	GRS BenchMate Adapter		\$17.15
C	21-0465	Ruby Belt	180	\$3.85
	21-0465	Ruby Belt	320	\$3.85
	21-0465	Ruby Belt	240	\$3.85
	21-0465	Ruby Belt	120	\$3.85
	21-0465	Ruby Belt	80	\$3.85

**3M® REGAL XODUST 930DZ**

These purple belts are coated with Cubitron<sub>z</sub> ceramic aluminum-oxide mineral. These are the best you can get when removal of material is required at a fast rate. Applications include sprue removal and casting clean-up. Good for all types of metal, wood, and plastics.

Item	Order #	Grit	W×L	12+	6+	1+
	21-0493	80	1"×10½"	\$2.48	\$2.59	\$2.70
	21-0494	120	1"×10½"	\$2.48	\$2.59	\$2.70
	21-0499	220	1"×10½"	\$2.48	\$2.59	\$2.70
D	21-0501	Set of three (one of each)		\$5.68	\$6.39	\$7.10

**FOREDOM®**



**FOREDOM® ALLSET MASTER KIT**

Used by professional setters, production stone setters, model makers, and designers. Both highly skilled and beginning stone setters will do their stone setting work faster and better—stone after stone. Improves stone setting quality because stones are set straighter, are level, held tighter, and less likely to break when channel or bezel setting are hammered.

Item	Order #	Description	1+
E	34-3000	Master Kit No. 30 Handpiece with DVD	\$449.00
F	34-3002	29-Minute How To DVD	\$5.60



**SHEENUS NEO ULTRASONIC POLISHER**

The NSK Sheenus Neo System can be used for grinding, polishing, removing burrs, and mirror-finishing on a wide range of materials from aluminum dies to cemented carbide dies. It is also perfect for plastic molds, precision molds, electronic dies, ceramic components, press, casting, forging, trimming, and header dies. This tool can quickly remove hard layers of EDM deposits and polish difficult areas such as complex corners and ribs. Power source: 120V. Output: 45 watts



Order #	Description	W×L×H	1+
35-1234	Ultrasonic Polisher	7½"×8½"×3½"	\$2,203.20

*Ceramic stones listed below are used with the Sheenus NFO Ultrasonic Polisher.*

**CERAMIC STONES**

Ceramic stones are designed for stoning tight corners, pockets, ribs, and slots. One of our most popular series of finishing stones, these are ideal for finishing EDM surfaces. Ceramic super stones will withstand considerable pressure for their relative thinness. The grit of the ceramic fiber is exposed in the cross section of the stones.

**Order # 21-12000**

Item	Grit	Color	W×L (mm)	Thickness (mm)	12+	6+	1+
<b>RECTANGLE</b>							
A	300	Light Brown	2½×100	1	\$10.76	\$11.23	\$11.70
B	400	Orange	2½×100	1	\$10.76	\$11.23	\$11.70
C	600	Brown	2½×100	1	\$10.76	\$11.23	\$11.70
D	800	Blue	2½×100	1	\$10.76	\$11.23	\$11.70
E	1000	White	2½×100	1	\$10.76	\$11.23	\$11.70
F	1200	Red	2½×100	1	\$10.76	\$11.23	\$11.70
<b>CYLINDER</b>							
G	300	Light Brown	3½×50	3½	\$24.15	\$25.20	\$26.25
H	400	Orange	3½×50	3½	\$24.66	\$25.73	\$26.80
J	600	Brown	3½×50	3½	\$16.70	\$16.70	\$16.70
K	800	Blue	3½×50	3½	\$24.66	\$25.73	\$26.80
L	1000	White	3½×50	3½	\$24.66	\$25.73	\$26.80
M	1200	Red	3½×50	3½	\$24.66	\$25.73	\$26.80

*Ceramic stones are used with Sheenus NFO Ultrasonic Polisher shown above.*

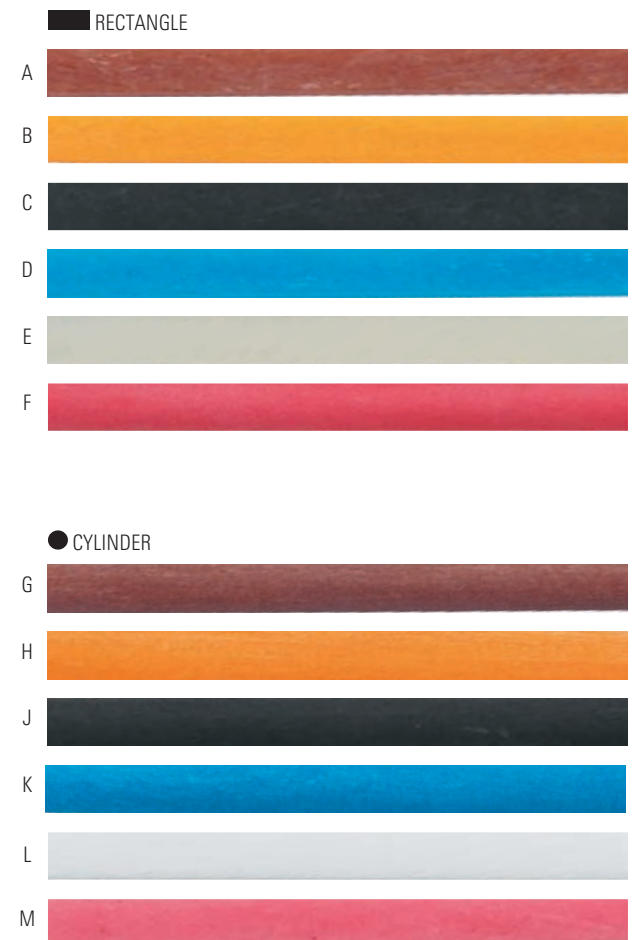



# GAUGES AND MANDRELS



### TRUE-SIZE RING SIZING SYSTEM

TRUE-SIZE precision-calibrated ring-sizing set delivers consistent, dependable results from start to finish when sizing rings. Whether you are designing new rings or resizing existing rings, this set reduces costly errors that can occur between measuring the size needed and producing that size in the end product. Kit includes 47 Comfort Fit, 3mm-wide stainless steel ring sizes are marked in half-sizes for 1-16, quarter-sizes for 4-12. Sizes are laser-etched onto a flat spot on the exterior surface of each ring, making it easy to select the size you need. Comfort Fit bands have substantial weight and are rounded on the inside for a very comfortable fit. One 12-1/2"-long aluminum ring stick clearly etched in quarter-sizes from 1-16 with a sizing gauge makes it easy to remove or insert exactly the amount of metal necessary when sizing up or down.

Order # 35-1094

Description	1+
3mm TRUE-SIZE Ring Sizing System	\$179.00
5mm TRUE-SIZE Ring Sizing System	\$195.00

The wood presentation box also has a sizing conversion chart.



### TRUE-SIZE BRACELET MANDREL

This True-Size mandrel simultaneously measures both the inside circumference and inside diameter of bangles and bracelets from 6.67" (169.4mm) to 9.42" (239.3mm) circumference and from 2.125" (54mm) to 3.0" (76.2mm) diameter.

Order #	Description	Sizes	12+	6+	1+
35-2917	Bangle Mandrel	2.125-3.0	\$24.65	\$26.10	\$29.00

### TRUE-SIZE

Manufactured by Ikohe to the design specifications of renowned tool maker Kate Wolf, the TRUE-SIZE precision calibrated ring stick delivers consistent, dependable results from start to finish when sizing rings. Whether you are designing new rings or resizing existing rings, this set reduces costly errors that can occur between measuring the size needed and producing that size in the end product—especially when partnered with the calibrated TRUE-SIZE finger gauge set and steel mandrel (available separately). This 12-1/2" long aluminum ring stick is clearly etched in quarter sizes from 1-16 with a handy sizing gauge that makes it easy to remove or insert exactly the amount of metal necessary when sizing up or down.

Item	Order #	Description	Sizes	12+	6+	1+
A	35-1095	Mandrel Only	1-16	\$28.90	\$30.60	\$34.00
B	35-1087	Grooved Steel mandrel ¼ Sizes	1-16	\$30.60	\$32.40	\$36.00
B	35-1087	Grooved Steel Mandrel ½ Sizes	1-16	\$32.30	\$34.20	\$38.00
C	35-1086	Ungrooved Steel Mandrel ½ Sizes	1-16	\$32.30	\$34.20	\$38.00
C	35-1086	Ungrooved Steel Mandrel ¼ Sizes	1-16	\$30.60	\$32.40	\$36.00

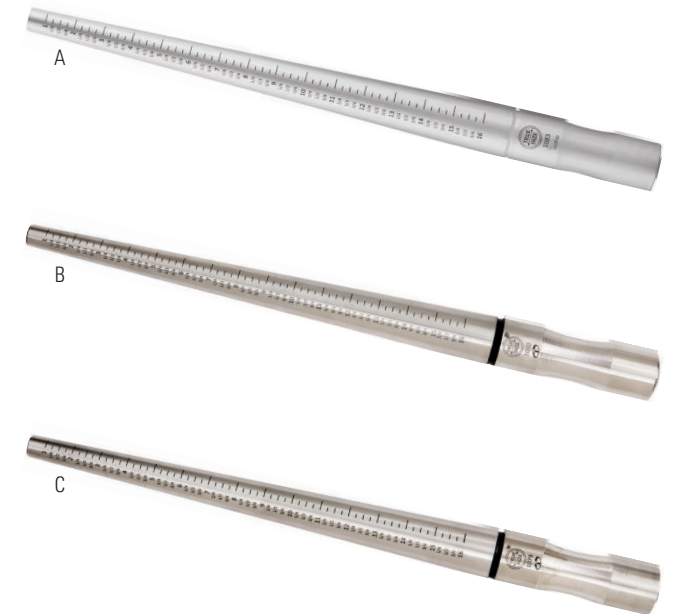

### DURSTON HARDENED STEEL NON-GROOVED MANDREL

Durston's high quality tapered ring mandrels use hardened steel to 64 RC. Available grooved or non-grooved marked quarter sizes 1-16.

Order #	Description	Sizes	12+	6+	1+
35-2616	Hardened Steel Grooved Mandrel	1-16	\$33.15	\$35.10	\$39.00
35-2616	Hardened Steel Non-Grooved Mandrel	1-16	—	—	\$39.00



### DURSTON RING GAUGE

Stamped from steel stock, this Durston unfinished finger gauge set is precisely machined and calibrated to match the Durston ring stick and ring mandrel to provide excellent consistency from showroom to bench to customer. This set includes U.S. sizes 1–16 in clearly marked half-size increments.

Order #	Description	Ring Sizes	1+
35-2617	Durston Ring Gauge	1-16	\$25.00



All items are priced at jeweler's cost, are sold each, unless otherwise noted, and are subject to change without notice. Visit [Stuller.com](http://Stuller.com) for our complete product selections, current pricing, and quantity price breaks. | 295



**HOLLOW RING MANDRELS**

Hollow, metal ring stick. Has gauge for material length needed to make specific size rings. Nickel-plated with wood handle. Graduated in U.S. standard quarter sizes.

Item	Order #	Description	Ring Sizes	12+	6+	1+
A	35-2840	Grooved	1-15mm	\$22.82	\$24.17	\$26.85
B	35-2860	Non-Grooved	1-15mm	\$17.98	\$19.04	\$21.15



**PLASTIC RING STICK**

Plastic ring stick. Graduated in U.S. standard quarter sizes.

Item	Order #	Description	Ring Sizes	12+	6+	1+
C	35-2880	Grooved	1-15mm	\$4.42	\$4.68	\$5.20



**ALUMINUM RING MANDRELS**

Solid, aluminum ring stick. Graduated in U.S. standard quarter sizes.

Item	Order #	Description	Ring Sizes	12+	6+	1+
D	35-2800	Grooved	1-13mm	\$18.70	\$19.80	\$22.00
E	35-2820	Non-Grooved	1-13mm	\$18.23	\$19.31	\$21.45



**ALUMINUM RING MANDRELS**

Solid, aluminum and gold anodized ring stick. Graduated in U.S. standard quarter sizes.

Item	Order #	Description	Ring Sizes	12+	6+	1+
F	35-2999	Grooved	1-16mm	\$26.52	\$28.08	\$31.20
G	35-2998	Non-Grooved	1-16mm	\$26.52	\$28.08	\$31.20



**STEEL STEPPED RING MANDRELS**

Avoid distortion caused by tapered mandrels on wide shank rings. Marked graduated sizes.

Item	Order #	Ring Sizes	Increments	Length	12+	6+	1+
H	35-2902	4-16mm	Whole	13½"	\$29.96	\$31.73	\$35.25
J	35-2903	3.5-15.5mm	Half	13½"	\$29.96	\$31.73	\$35.25

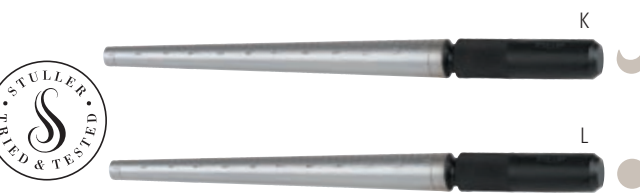

**STEEL RING MANDRELS**

Item	Order #	Description	Ring Sizes	Length	12+	6+	1+
K	35-2914	Grooved	1-12mm	12"	\$28.09	\$29.75	\$33.05
L	35-2912	Non-Grooved	1-12mm	12"	\$28.09	\$29.75	\$33.05



**DURSTON FORMING RING MANDRELS**

Durston's new high quality forming and tapered ring mandrels. Hardened to 64 RC. Two sizes available: 10mm-25mm and 10mm-28mm.

Item	Order #	Description	Ring Sizes	Length	12+	6+	1+
M	35-2915	Non-Grooved	10-28mm	16"	\$33.75	\$35.73	\$39.70
N	35-2915	Non-Grooved	10-25mm	14½"	\$30.94	\$32.76	\$36.40



**STEEL RING MANDRELS**

Larger ring mandrel.

Item	Order #	Shape/Style	Ring Sizes	Length	1+
A	35-2910	Round, Grooved	1-16mm	13½"	\$31.95
B	35-2900	Round, Non-Grooved	1-16mm	13½"	\$31.95



**STEEL RING MANDREL**

Flat-sided ring mandrel. Used for forming, straightening, or enlarging bezel-set rings. Can also be used in place of a grooved mandrel.

Item	Order #	Shape	Ring Sizes	Length	1+
C	35-2916	Half Round	1-16mm	13½"	\$33.05



**STEEL SPECIALTY MANDREL**

Unmarked mandrel.

Item	Order #	Shape	Ring Sizes	Length	1+
D	35-2909	Square	6.8-17.7mm	13½"	\$41.85



**MICRO-MANDRELS**

E. This micro-round mandrel is ideal for making jump rings and other small findings. The hardened steel is precision ground and 160mm in length. Made in Switzerland.

F. This small, round mandrel is suited to fabricating and forming jump rings, small bezels, and rings. The hardened steel is precision ground and 220mm in length. Made in Italy.

G. This small, oval mandrel is suited to fabricating and forming jump rings, small bezels, and rings. The hardened steel is precision ground and 220mm in length. Made in Italy.

H. This small, square mandrel with sharp edges is used for making joints and bezels. The hardened steel is precision ground and 220mm in length. Made in Italy.

Item	Order #	Shape	Tapers To (mm)	Length	1+
E	35-2980	Round	1.5-5mm	6¼"	\$36.40
F	35-2981	Round	3-10mm	8½"	\$32.00
G	35-2982	Oval	3-10mm	8½"	\$42.85
H	35-2983	Square	4-10mm	9"	\$38.50

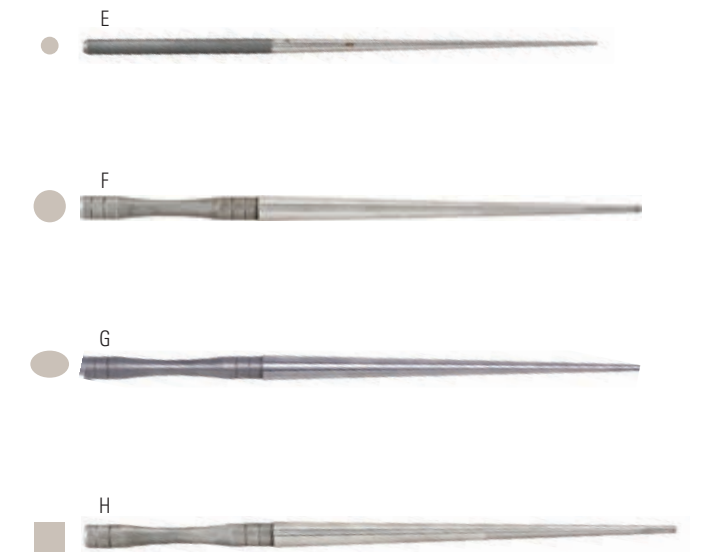

**WOODEN RING MANDRELS**

Ring stick made of finely finished hardwood, excellent for glass counters and wire work. Will not mar or scratch the ring while hammering or shaping.

Item	Order #	Description	Ring Sizes	Length	12+	6+	1+
J	35-2947	Non-Roll Hex Handle	3-15mm	12½"	\$11.90	\$12.60	\$14.00
K	35-2945	Shaping		11½"	\$5.61	\$5.94	\$6.60





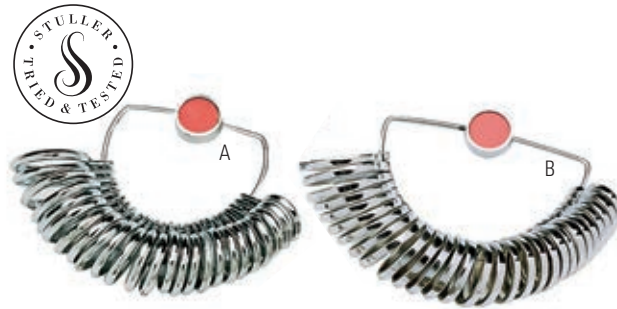

**FINGER GAUGE**

Nickel-plated finger gauges graduated in U.S. standard half-sizes.

Item	Order #	Description	Ring Sizes	Increments	12+	6+	1+
A	35-2613	3mm/Half-Round	1-15mm	½"	\$12.75	\$13.50	\$15.00
B	35-2615	2.8mm/Flat	1-15mm	½"	\$15.47	\$16.38	\$18.20
C	35-2620	6mm/Flat	1-15mm	½"	\$14.03	\$14.85	\$16.50
D	35-2622	3.9mm/Flat	16-24mm	½"	\$8.67	\$9.18	\$10.20
E	48-7525	4mm/Comfort-Fit	1-15mm	½"	\$14.03	\$14.85	\$16.50
F	35-2611	2.8mm/Flat	1.25-12.75mm	¼"	\$14.03	\$14.85	\$16.50
G	35-2621	6.8mm/Half Round	1-15mm	½"	\$17.77	\$18.81	\$20.90
H	48-7526	7mm/Comfort-Fit	1-15mm	½"	\$14.96	\$15.84	\$17.60

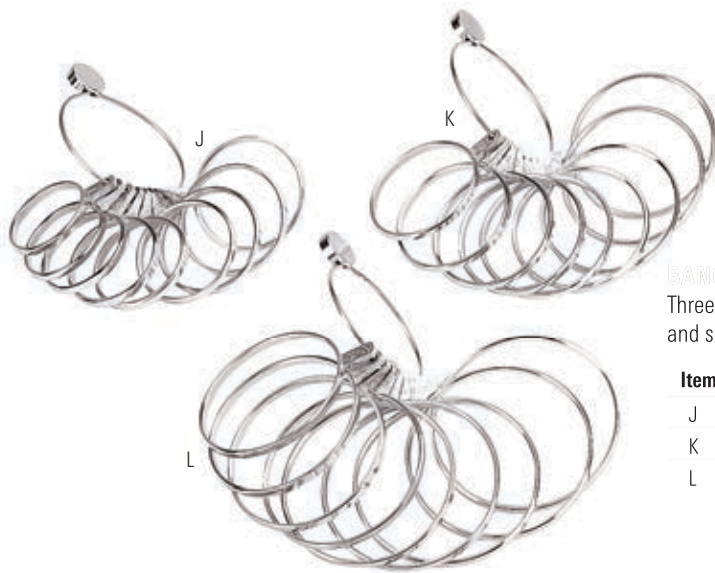

**BANGLE/BRACELET GAUGE**

Three sizes of bracelet gauges. All are heavy gauge base metal, nickel-plated, and securely attached to a handy 2 ¾" ring.

Item	Order #	Description	Ring Sizes	12+	6+	1+
J	35-2605	Small	1-9mm	\$9.35	\$9.90	\$11.00
K	35-2606	Medium	10-18mm	\$9.35	\$9.90	\$11.00
L	35-2607	Large	19-27mm	\$9.35	\$9.90	\$11.00

**PLASTIC FINGER GAUGE**

The perfect complement to your standard ring sizer. Give your customer a perfect fit every time. Available in quarter sizes and a combination of full and half sizes. With easy-to-read rings on a metal chain and disposable rings on a sheet. U.S. standard sizes.

Item	Order #	Description	Ring Sizes	12+	6+	1+
A	35-2625	Quarter Sizes (no half sizes)	4.25-13.25mm	\$3.74	\$3.96	\$4.40
B	35-2650	Full and Half Sizes	4-12mm	\$1.49	\$1.58	\$1.75
C	35-2626	Disposable Sheet	2.5-14mm	\$0.47	\$0.50	\$0.55

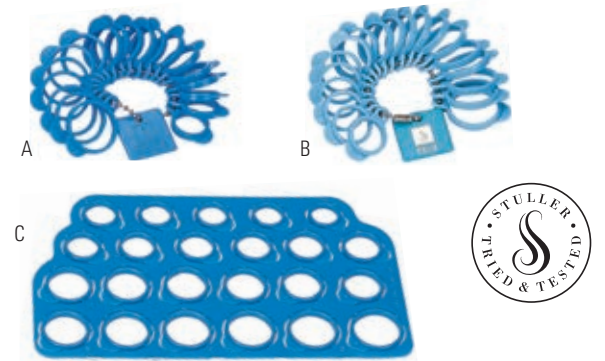

**MULTI FINGER SIZER**

Customers can easily and confidentially measure their own finger sizes from 0-17 with accurate full, half, and quarter sizes. The low price of this multi sizer means you can give them away when a customer wants to buy that surprise ring for a special gift. Multi sizers come in individual envelopes with instructions.

Order #	Description	Ring Sizes	12+	6+	1+
35-2610	Multi-Sizer	1-17mm	\$0.43	\$0.45	\$0.50



**ACCUSIZER**

Sturdy, lightweight plastic that open and close identical Superfit® shanks.

Order #	Description	Ring Sizes	12+	6+	1+
35-2614	Accusizer Ring Sizer	2-11.5mm	\$7.48	\$7.92	\$8.80



**CHAIN GAUGES**

Necklace Gauge, measuring in centimeters.

Order #	Description	Sizes	12+	6+	1+
35-2600	Bracelet	14-26cm	11.86	12.56	13.95
35-2600	Necklace	30-80cm	25.46	26.96	29.95



**HANDY SIZER RING GAUGE**

New, thin flat ring sizer that fits in your pocket. Customers can inconspicuously take it home to measure a ring. Has a handy millimeter gauge on the end.

Order #	Description	Sizes	12+	6+	1+
35-5117	Plastic Gauge	1.5-12mm	\$4.25	\$4.50	\$5.00



**SHANK SIZE AND BRACELET GAUGE**

Used for measuring wire or flat stock for proper size ring and bracelet shanks. Includes guide to various shapes and sizes of metal. Ring sizes from 1 to 14; bracelets from baby's to large men's sizes.

Order #	Description	Ring Sizes	12+	6+	1+
35-0425	Shank and Bracelet Gauge	6-26mm	\$3.49	\$3.69	\$4.10

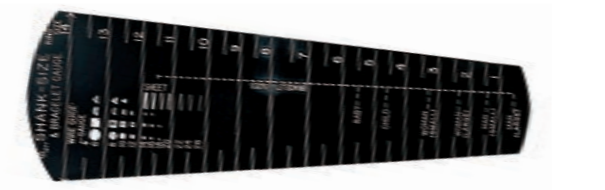



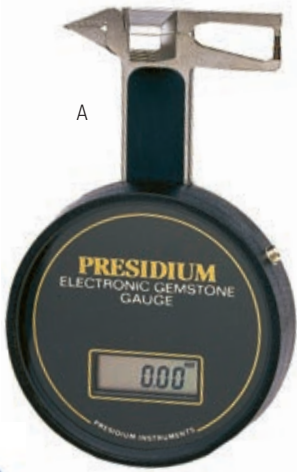

**PRESIDIUM DIGITAL GEMSTONE GAUGE**

Electronic digital gemstone gauge. Uses battery CR2032.

Features:

- Range 0 to 25mm
- Slipper measuring platform
- Zero reset button
- Wedge-shaped points
- Auto shut-off when placed in case
- Fixed rod

Item	Order #	Description	12+	6+	1+
A	<b>35-1814</b>	Digital Gemstone Gauge	\$281.75	\$298.32	\$331.47

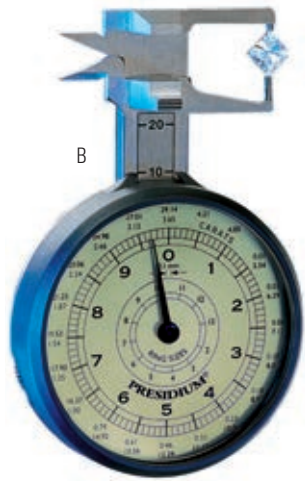

**PRESIDIUM DIAL GAUGE**

The Presidium dial gauge incorporates the latest technological design, construction, and features. Measurements are precise from 0 to 23mm with 0.1mm accuracy. Direct, carat-weight reading on dial. Accuracy maintained with wear-resistant, hardened anvils. Reduces hand fatigue because it is 20% lighter than other gauges. Manufactured with Swiss-made hardened steel and components. Comes with polishing cloth, weight estimation table, instructions, and accessory booklet.

Item	Order #	Description	12+	6+	1+
B	<b>35-1812</b>	Presidium Dial Gauge	\$149.56	\$158.36	\$175.95



**DIGITAL GAUGE**

Three button gauge measures three decimal places in millimeters or inches. Zeros at any setting. Made of high-impact plastic, and measuring tips are stainless steel. Auto shut-off. Case included. 0-20mm, .01 accuracy. Uses Battery 357.

Item	Order #	Description	12+	6+	1+
C	<b>35-1817</b>	Digital Gauge	\$65.88	\$69.75	\$77.50

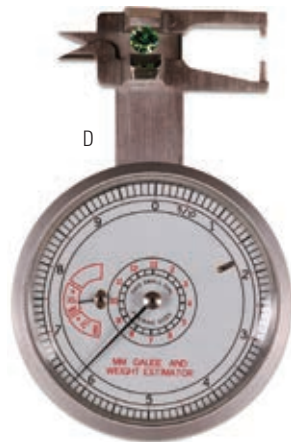

**ANALOG GAUGE**

For those who prefer an analogue gauge, this one measures 0-23mm with 0.1mm accuracy. Made of stainless steel for rugged use and three-way measurements. Case included. B&S thickness conversion table on the back.

Item	Order #	Description	12+	6+	1+
D	<b>35-1813</b>	Analog Gauge	\$92.78	\$98.24	\$109.15

**QUICK DIGITAL GAUGE**

Very easy, thickness measurement for samples that are small, round, narrow, and thin shapes. The Quick Digital Gauge has a flat face measuring tip, so that small objects can be measured on the table. Also there is spring force of measurement point for constant and quick accurate readings. Uses Battery CR2032.

Item	Order #	Description	12+	6+	1+
A	<b>35-1821</b>	Quick Digital Gauge	\$98.56	\$104.36	\$115.95



**CARBON FIBER DIGITAL THICKNESS GAUGE**

This digital thickness gauge is lightweight and easy to use. It features a large, easy to read LCD display and its carbon fiber composite construction makes it both lightweight and durable.

- 8 mm LCD display
- Measuring range: 0-12 mm
- Resolution: 0.01 mm

Item	Order #	Description	1+
B	<b>35-5628</b>	Carbon Fiber Digital Thickness Gauge	\$10.35



**COMPACT DIGITAL GAUGE**

This Compact (pocket) digital gauge measures from 0 to 25mm and 0 to 1". Millimeter accurate to two decimal points and inch fractions to three decimal points. Stainless steel with high-impact plastic housing. Inside and outside measurements. Comes with protective case. Uses Battery 357.

Item	Order #	Description	1+
C	<b>35-1818</b>	Compact Digital Gauge	\$68.00



**MILLIMETER GAUGE**

Excellent for measuring pearls and stones of all kinds. Smooth action assures accuracy. Gauge is made to zero out when closed, and open automatically. This assures a gentle force when measuring soft stones and pearls. Dial features "zero adjust" and is accurate to 0.1mm. Maximum opening width is 20mm. Made in China.

Item	Order #	Description	1+
D	<b>35-1200</b>	Millimeter Pearl Gauge	\$33.00

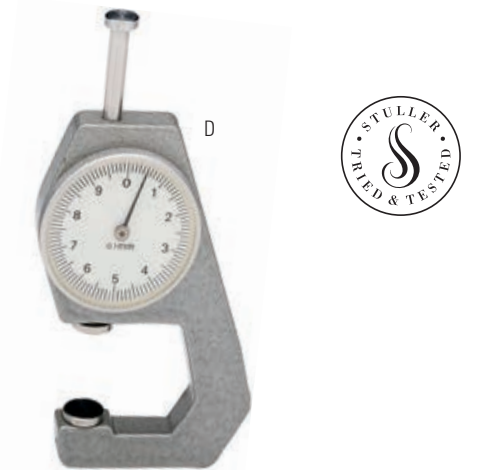



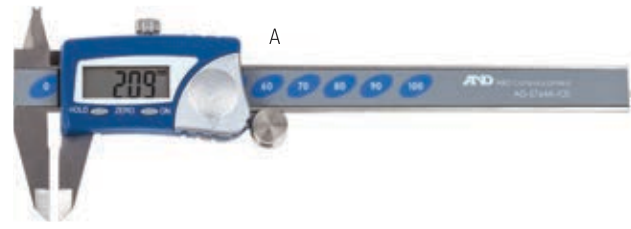

**A&D DIGITAL CALIPER**

Easy measurement basic style digital A&D caliper. Measurements range from 0.01mm-100mm. Uses Battery CR2032.

Item	Order #	Description	Length	1+
A	35-1803	A&D Digital Caliper	6"	\$49.95

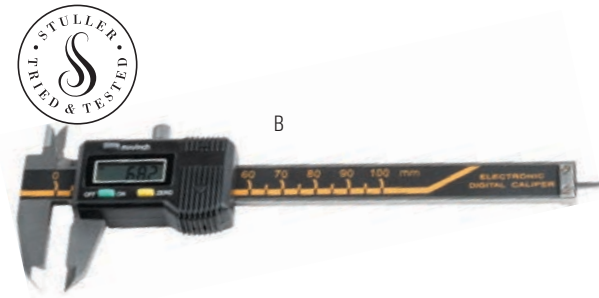

**ELECTRONIC DIGITAL CALIPER**

Stainless steel, instant readout digital caliper. Measures inside, outside, and depth. Accurate to 0.0005" (0.01mm). Measuring range from 0 to 6" (0 to 100mm). Includes protective case and battery EBAT357.

Item	Order #	Description	Length	1+
B	35-1797	100mm Digital Caliper	4"	\$26.50

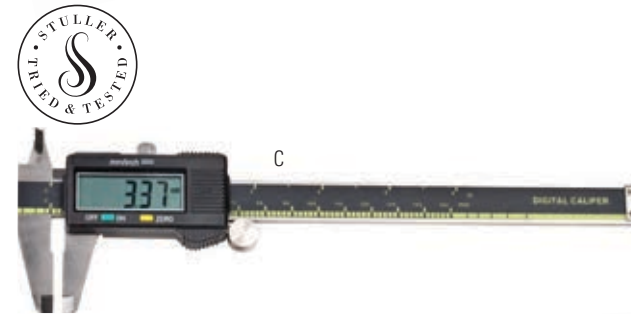

**DIGITAL CALIPER**

Electronic Digital Caliper with large LCD readout. Measures ID and OD from 0.0005" (0.01mm). Depth measures from 0 to 150mm. Takes a SR44 (EBAT357) battery.

Item	Order #	Description	Length	1+
C	35-1798	150mm Digital Caliper	6"	\$32.00

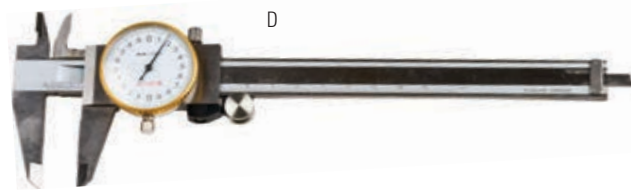

**DIAL CALIPER**

Stainless steel dial caliper measures inside, outside, and depth. Accurate to 0.02mm. Measuring range from 0 to 150mm. Easy to read "adjust to zero" dial and thumb roller with lock. Maximum opening 6".

Item	Order #	Description	Length	1+
D	35-1830	150mm Dial Caliper	9 3/8"	\$23.70

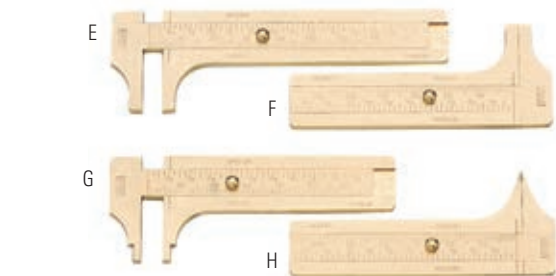

**BRASS SLIDING GAUGES**

Each gauge is a combination of millimeter and inches. Available in standard, pointed, or notched. (Notched jaw measures inside or out.) Made in Germany.

Item	Order #	Description	Length	12+	6+	1+
E	35-1522	Standard	3 1/4"	\$11.18	\$11.84	\$13.15
F	35-1520	Standard	2 1/4"	\$10.29	\$10.89	\$12.10
G	35-1524	Notched	2 1/4"	\$10.29	\$10.89	\$12.10
H	35-1526	Pointed	2 1/4"	\$12.07	\$12.78	\$14.20

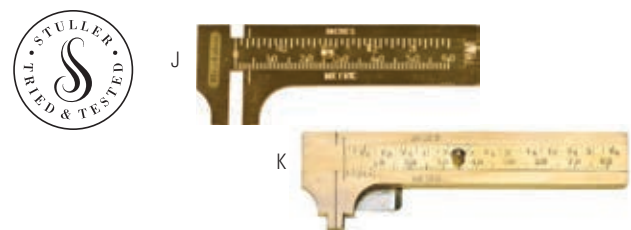

**GAUGE DELUXE**

Metal underplate holds small stones and parts in place to allow fast and accurate measurements. Also works great for normal measurements. Plate is non-removable.

Item	Order #	Description	Length	12+	6+	1+
J	35-1529	Beadalon Gauge	2 1/2"	\$7.01	\$7.43	\$8.25
K	35-1528	Stone Gauge	3 1/4"	\$8.46	\$8.96	\$9.95

**DIAMOND SELLER**

Used to show sizes of brilliant-cut diamonds. Cubic zirconias are mounted on stainless steel arms. Each arm is marked with size and carat weight. Shows 10 sizes from 0.1 to 2 carats. Folds within a protective cover when not in use.

Order #	Description	12+	6+	1+
35-5550	Stainless Steel Diamond Seller	\$50.62	\$53.60	\$59.55



**DIAMOND OR GEMSTONE FAN GAUGE**

Pocket stainless steel gauge for measuring brilliant-cut, marquise, pear, square, emerald, and oval-cut stones. Measures 3 1/2" closed. Stone measurements are in carat weights. Made in the USA. Seven blades.

Order #	Description	Width	12+	6+	1+
35-5610	Diamond/Gem Fan Gauge	3 1/2"	\$15.56	\$16.47	\$18.30



**K&B DIAMOND AND STONE GAUGE**

Pocket gauge used for measuring loose stones and settings ranging from three points to four carats. Made of aluminum. Reverse side is embossed with birthstone chart.

Order #	Description	12+	6+	1+
35-5602	Aluminum Diamond and Stone Gauge	\$6.67	\$7.07	\$7.85



**STONE AND MOUNTING GAUGE**

Aluminum gauge with holes used to measure stones, and the extensions are used to measure mountings. One side indicates millimeters; the other side indicates the corresponding carat measurement.

Order #	Description	Stone Sizes	12+	6+	1+
35-5515	Stone and Mounting Gauge	2-11mm	\$12.16	\$12.87	\$14.30



**DIAMOND GAUGE**

Measures round and baguette stones from 1/1000 to 2 carats. Made of aluminum. Folds to 1 1/2" in diameter.

Order #	Description	Width	12+	6+	1+
35-5600	Diamond Gauge	1 1/2"	\$6.33	\$6.71	\$7.45



**PREMIUM BRACELET GAUGE**

Quality bracelet size gauge for fitting bracelets. Adjustable band with sizes marked from 5" to 9" in 1/4" increments. Made of high-grade steel. Imported from France.

Order #	Description	Gauge Increments	12+	6+	1+
35-2612	Bracelet Gauge	1/4"	\$17.00	\$18.00	\$20.00



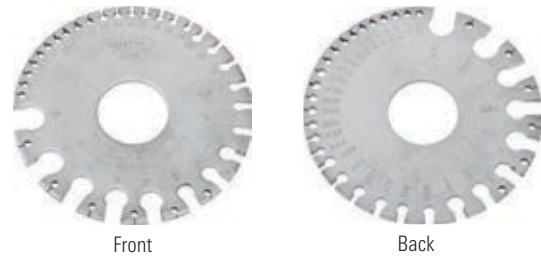

**PRECISION WIRE AND SHEET GAUGE**

American standard wire and sheet gauge used for measuring wire and sheet metals from 0 to 36 gauge. Chrome-finished, heavy-gauge, hardened and tempered tool steel. Decimal equivalents of each size are stamped on reverse side. Measures 3/4" diameter and 3/32" thick.

Order #	Description	12+	6+	1+
35-5609	Wire/Sheet Gauge	\$21.68	\$22.95	\$25.50

**STAINLESS STEEL FLEXIBLE RULER**

Overall length 6" and width 1/2". Top is graduated in millimeters and 1/32" increments across the lower half. All graduations are deeply etched.

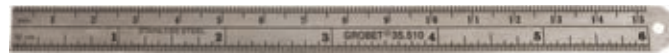

Order #	Width	Length	12+	6+	1+
35-5100	1/2"	6"	\$1.79	\$1.89	\$2.10

**JEWELRY MAKER'S SCALE**

Covers all the jeweler's ring shank, bracelet, and sheet measuring needs. Stainless steel with etched graduations for permanent visibility. Six-inch scale graduated in 1/16", 150mm scale graduated in millimeters. Shows metal length required for bracelet to fit any wrist size.



Order #	Length	12+	6+	1+
35-5115	6"	\$5.68	\$6.01	\$6.68

**MULTI USE RULER GAUGE**

This pocket tool performs several separate and distinct functions. The bevel protractor is used for measuring and laying out angles. The center finder locates centers of circles. The circle divider is used for dividing circles into sectors. Made of stainless steel, the ruler has etched graduations in inches and millimeters.



Order #	Length	12+	6+	1+
35-5104	4"	\$9.35	\$9.90	\$11.00

**STAINLESS STEEL PROTRACTOR**

Set bevels, and measure and transfer angles with this stainless steel protractor. Made of ground stainless steel for optimum accuracy. Permanently etched graduations from 0 to 180° in opposite directions. Six-inch adjustable protractor locks into position with knurled thumb nut and 3 3/8" x 2" head.



Order #	Description	12+	6+	1+
35-5106	Adjustable Protractor	\$13.09	\$13.86	\$15.40

**MARK-A-SIZE**

Used to scribe cutting lines accurately when reducing ring sizes. Consists of 12 sizes that are graduated in quarter ring sizes from 1/4" to 3". Made of hardened steel with sharp edges. Folds when not in use.



Order #	Description	12+	6+	1+
35-0705	Mark-A-Size	\$38.08	\$40.32	\$44.80



**COMBINATION DEGREE GAUGE**

Lightweight and made of polished steel with easy-to-read brass indices. Adjustable point for close tolerance work. Three-quarter inch jaw. Capacity 72 lignes and 120mm.

Order #	Description	12+	6+	1+
35-0140	Combination Degree Gauge	\$38.46	\$40.73	\$45.25



**KERR' CALIPER**

Stainless steel and calibrated in 0.1mm, this caliper is excellent for measuring wall thicknesses. Rounded tip caliper works well for wax carving.

Order #	Description	12+	6+	1+
21-0025	Round Tip Caliper	\$31.88	\$33.75	\$37.50



**JO-DI DIAMOND WEIGHT GAUGE**

Used to estimate carat weights for four basic diamond shapes (round, marquise, emerald, and pear) without removing stones from mounting. Measure depth and width with caliper and then compare with tables in the 70-page reference booklet provided. Instructions in four languages: English, French, Spanish, and German. Sold with wallet. Made of metal. One side measures in millimeters and the other in carats.

Order #	Description	12+	6+	1+
35-5510	Diamond Weight Gauge	\$33.96	\$35.96	\$39.95



**DEGREE GAUGE**

Light weight and made of coated steel with and easy-to-read brass indices. Adjustable point for close tolerance work.

Order #	Description	12+	6+	1+
35-0300	0-15 mm	\$14.41	\$15.26	\$16.95



**SPRING DIVIDER WITH ADJUSTABLE POINTS**

Sharp, pointed tips are adjustable and can be replaced. Maximum opening 2 3/4" with tips retracted or 3 1/4" with tips extended. Special quick-adjustment nut and heavy-duty spring. Made in Germany.

Item	Order #	Description	Length	12+	6+	1+
A	35-0805	Spring Divider	2 1/2"	\$12.20	\$12.92	\$14.35
B	35-0806	Replacement Tips (sold per pair)		\$2.25	\$2.39	\$2.65

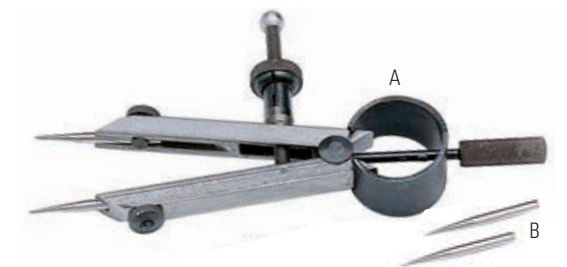





**STARRET DIVIDER**

Highly-polished dividers made of spring steel with hardened, tempered, and well-balanced round legs. Floating washer and thumb screw permit fast and positive adjustment.

Order #	Description	Length	12+	6+	1+
21-1128	Divider with 3 inch legs	3"	\$63.75	\$67.50	\$75.00



**SPRING DIVIDER**

Features heavy-duty, spring action with a special, quick-adjustment nut. The perfect tool for measuring distances between points and scribing circles and arcs. Made in Germany.

Order #	Max Opening	Leg Length	12+	6+	1+
35-0800	2¼"	3"	\$12.20	\$12.92	\$14.35
35-0802	6½"	6"	\$13.18	\$13.95	\$15.50



**DIAMOND SIEVES**

Used for sorting stones, beads, and pearls according to size. Complete set of 21 plates fit in zippered carrying case. Chart indicates plate size of stones per carat, weight, and millimeter size.

Item	Order #	Description	12+	6+	1+
A	51-0560	1½ in. (1.1mm-4.5mm)	\$59.46	\$62.96	\$69.95
B	51-0565	2½ in. (0.74mm-4.45mm)	\$108.12	\$114.48	\$127.20



**SIEVE HOLDER BOX**

Plastic holder box for stone sieves. Designed to hold 42 sieves.

Order #	WxLxH	12+	6+	1+
51-0569	12"×4½"×4½"	\$25.08	\$26.55	\$29.50



**MELEEMETER MICROGAUGE SYSTEM**

Meleemeter microgauge system consists of 10 business-sized-card templates encased in a solid brass carrying case for safe keeping. These templates will eliminate the need for measuring and computing melee weights with 590 melee shapes and sizes placed around the edges, giving maximum access to mounted melee. Contains gauge for trillion diamonds including weight formulas.

Order #	Description	12+	6+	1+
35-5617	MicroGauge System	\$46.71	\$49.46	\$54.95

**NECKLACE MANDREL**

Polished cast iron shapes necklaces perfectly and easily. Work metals or use this mandrel to form wax. Made in Italy.



Order #	Description	WxLxH	12+	6+	1+
35-2964	Necklace Mandrel	8½"×7¾"×7"	\$105.70	\$111.92	\$124.35

**ROUND HOOP MANDREL**

Hard chrome-plated steel with a highly polished surface and tapers for a wide range of rings, earrings, hoops, and bracelets. The mandrel gives a great variety of uses for goldsmiths, silversmiths, jewelers, and bead artists.



Order #	Shape	Ring Sizes	Length	1+
35-2810	Round	¾"-2"	12"	\$29.70

**ROUND WOOD BRACELET MANDRELS**

Made of wood to help prevent marring and scratching when shaping and forming bracelets and other round items.



Item	Order #	Description	Tapers To	12+	6+	1+
A	35-2940	Small	¾"-2"	\$12.75	\$13.50	\$15.00
B	35-2941	Medium	1½"-2½"	\$14.96	\$15.84	\$17.60
C	35-2942	Large	2"-3½"	\$15.90	\$16.83	\$18.70

**TAPERED BRACELET MANDRELS**

Hollow cone, case-hardened mandrels. Used for shaping, stretching, and forming bracelets and other items. Made in India.



Item	Order #	Shape	Tapers To	Length	1+
E	43-0500	Oval	1¾" x 1¼" - 3" x 3½"	15"	\$39.65
F	43-0540	Round	1¾" - 3½"	15"	\$39.65

**DURSTON RING MANDRELS**

This high-quality, hardened, and polished steel mandrel is ideal for shaping and forming bracelets. Offered in two shapes of round and oval.



Item	Order #	Description	Length	1+
D	43-0501	Round	15"	\$119.60

**BRACELET BUTLER®**

Fasten jewelry and watch clasps with one hand. No more struggling to hold bracelets and watches against the body where clasps can't be seen. Bracelet Butler® is designed to expand to fit larger size wrists. The comfort pads hold bracelets and watches in position for hand to fasten clasps. Easy to position your wrists under a light to aid fastening. Great for arthritis sufferers. Perfect gift for the person who seems to have everything. Made in America. Simple and easy to use.

- Drape the bracelet on the wrist so the clasp is facing you.
- Place one end of the Bracelet Butler® on top of the bracelet near the clasp with your free hand.
- Trap the bracelet between the Bracelet Butler® and the wrist leaving the clasp hanging free.
- Close the bracelet clasp with your free hand. Remove the Bracelet Butler®



Item	Order #	Description	12+	6+	1+
G	54-4200	Bracelet Butler	\$4.93	\$5.22	\$5.80

# GEMOLOGICAL INSTRUMENTS



### GIA® MICROSCOPE

- Electrically noise-free lighting environment
- GIA® patented dark field and bright field illumination
- Digital intensity control dark field
- Stable illumination, void of spikes, flickers, or yellowish color changes
- Two strategically designed illumination ports under the stage
- Digital 100-240 voltage auto switching internal optics
- GIA® designed
- Finest German lenses milled to GIA® specifications
- Stereo dual diopter power zoom magnification 10X to 64X
- Clear digital lighting substantially reduces eye fatigue
- Swivel base with patented stationary power cord eliminates tangles
- Wider work stage for optimum hand comfort
- Ergonomically designed, adjustable base promotes proper posture for viewing

#### Includes —

- Wire stone holder
- Eye guards
- Dust cover
- User guide
- GIA® HighView™

Item	Order #	Description	1+
A	29-1602	GIA® Research Series Microscope with LCD Readout	\$4,195.00

#### ACCESSORIES

B	61-1743	Wire Stone Holder	\$85.85
C	61-1742	Inclusion Pointer	\$95.95
D	61-1741	Color Grading Disc	\$80.15
E	61-1740	Diffuser Plate	\$201.95
F	29-1652	Overhead Light Source	\$495.00
G	29-1655	Darkfield Bulb for GIA Scope	\$34.65



### GEMORO® ELITE MODEL 1067 SIGNATURE SERIES MICROSCOPE

- The world's first LED dark field/bright field illumination signature microscope
- Precision 10X - 67X zoom with Japanese quality optics
- Offering the world's first LED dark field/bright field
- Rheostat controlled intensity, LED dark field/bright field illumination with adjustable iris diaphragm and sliding baffle
- Tilt with 55 degrees - Microscope head and base swivel 360 degrees

#### Includes —

- Dust cover
- Eye guards
- Full view gem clip
- A briefcase style metal carrying case

Item	Order #	Description	1+
A	29-4749	Elite 1067 Series Microscope	\$2,395.00



### GEMORO® ELITE MODEL 1067ZX

- 10X-67X zoom microscope with built-in additional overhead light source
- Superior Japanese quality optics
- True professional dark field/bright field illumination with a sliding baffle
- Adjustable iris diaphragm controls the width of the lower light
- 360-degree rotating head for convenience
- Includes full-view gem clip/stone holder, eye guards, and dust cover
- Features a five-year mechanical warranty and a two-year electrical warranty



Item	Order #	Description	1+
B	29-4755	Elite 1067ZX Series Microscope	\$999.00
C	29-4756	Replacement Upper Bulb	\$11.25
D	29-4756	Replacement Lower Bulb	\$15.25

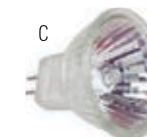

### GEMORO® SCOPE ELITE 1030 MICROSCOPE

- Superior Japanese quality optics.
- True professional dark field/bright field illumination with sliding baffle.
- Adjustable iris diaphragm controls width of the lower light.
- Internationally adaptable 110V-220V dual voltage powered.
- 360-degree rotating head.
- Comfort eye guards and dust cover included.



Item	Order #	Description	1+
E	29-4740	Elite 1030 Microscope	\$299.00
F	29-4741	Replacement Bulb, 12V/110W	\$5.05
G	29-4744	Replacement Stone Clip (fits models 1030 and 745)	\$49.95







**GEM ZOOM MICROSCOPE**

Ideal for retail counter sales presentations.

- 10X-40X magnification
- Dark field illumination
- Iris diaphragm for illumination control
- Overhead spot illumination
- Stone holder
- Designed for 110V and 220V



Item	Order #	Description	Power	1+
A	29-4780	Microscope	10X - 40X	\$415.54
B	29-4782	Replacement Bulb		\$3.60
C	29-4783	Replacement Iris		\$64.20



**GEMOLOGICAL MICROSCOPE**

- Great value at an affordable price
- View set and unset stones
- Versatile stone holder
- 20X-40X magnification
- Features built-in light and dark field illumination



Item	Order #	Description	Power	1+
D	29-1605	Microscope	20X - 40X	\$279.00
E	29-4782	Replacement Bulb		\$3.60



**DIAMOND INSCRIPTION READER DIGITAL MICROSCOPE**

This product is useful for jewelers, wholesalers, retailers, or gemological students. A 3 1/2 inch color LCD screen is used to identify the diamond laser inscription. Works with Windows XP, Windows Vista, Windows 7, Mac OS 10.6, or later. LED illumination helps to provide the best view.

Order #	Description	1+
13-1840	Inscription Reader Digital Microscope	\$279.00

**VISIO-TEK™ MICROSCOPES**

Featuring eight adjustable white LED lights, these versatile and portable digital microscopes utilize both Wi-Fi and USB transmission. Visio-Tek microscopes can be connected to iOS and Android smartphones or tablets via the Visio-Tek App, as well as through a Wi-Fi/USB connection to Windows and Mac computers or laptops. Using Visio-Tek dedicated software, you can capture pictures, shoot videos, and take measurements. This is the state-of-the-art way to observe the micro-world.

**Features—**

- Photo and Video resolution: 1.3MPx - 1280 x 1024, 640 x 480, 320 x 240
- Adjustable magnification: 5x - 200x
- Frame rate: Up to 30fps
- Polarizing Filter
- IEEE 802.11 b/g/n standards compliant
- Wireless transmission distance: up to 5m
- Frequency range: 2.400GHz - 2.4835GHz
- Li-ion battery: continuous working time - approximately two hours  
full charging time - approximately four hours
- Camera sensor: CMOS 1/4"
- Focus range: 8mm-200mm
- Lens: High definition microscopy lens
- Dimension: 36mm x 142mm (length)
- PC interface: USB 2.0
- Mini USB cable: 1.2m
- Power consumption: max 2.5W
- Light source: Eight adjustable white LEDs

Item	Order #	Description	1+
A	29-1520	Standard Microscope	\$309.00
B	29-1521	Polarized Microscope	\$349.00
C	29-1522	UV Microscope	\$349.00
D	29-1523	Flexible Gooseneck Microscope Stand	\$65.00
E	29-1524	Rigid Vertical Microscope Stand	\$99.00



**DINOLITE MICROSCOPE**

This handheld digital microscope/camera is easy to use and comes with an AV/TV output interface. High-resolution magnification is at your fingertips with detailed examination of any area you choose. Additional accurate measurement (not available on Mac OS) allows detailed analysis and documentation of the captured images. Both cameras also have eight LEDs with an on/off feature for illumination, as well as glare reduction. Included with each Dino-Lite digital microscope is a copy of the DinoCapture software, enabling you to capture either a photograph, video, or time-lapse video with a simple click. Computer not included.

Item	Order #	Description	Magnification	1+
F	29-1503	Digital Microscope/Camera (TV)	10x-200x	\$299.00
G	29-1502	Digital Microscope/Camera (USB)	10x, 50x, 200x	\$399.00
H	29-1501	Digital Microscope/Camera and Tabletop Stand	10x, 50x, 200x	\$499.00
J	29-1505	Flexible Desktop Stand Only		\$39.00
K	29-1504	Tabletop Stand Only		\$99.00
L	29-1499	Camera Stand		\$29.00





**GIA® MICROSCOPE**

- A. Critical in gem identification. Required for use of the GIA® Duplex II Refractometer. Store in cool, dark place.
- B. Top-of-the-line desk model refractometer is designed to spot read cabochons or small facets with diameters less than one millimeter. Features a removable eyepiece magnifiers that enlarges RI scale images and offers a hinged lid that protects glass working areas from dust and abrasion.

Item	Order #	Description	1+
A	29-4855	Refractive Index Liquid (10 grams)	\$95.60
B	29-4848	Duplex Refractometer (includes RI Liquid)	\$925.00



**REFRACTOMETER**

The refractometer has readings from 1.31 to 1.81 with pull out eyepiece. It gives you clear focus and reading. It has polarizing filter, monochromatic filter, and light source, RI liquid sold separately.

Order #	Description	1+
26-2604	Refractometer	\$159.00



**GIA® ILLUMINATOR POLARISCOPE**

The fastest way to test gemstones' optical properties. Quickly determine whether translucent or transparent gems are singularly or doubly refractive. Resolve optic character in doubly refractive gems, spot pleochroism, and detect diamond strain. Opening at front can double as light source. Includes interference figure sphere. Optional stone holder, mounts on both sides. Operates on 110V and 220V with a user changeable bulb.

Item	Order #	Description	1+
C	29-4840	Illuminator Polariscope	\$395.00
D	29-4841	110V Replacement Bulb	\$12.45
E	29-4842	Replacement Interference Figure Sphere	\$17.45

**POLARISCOPE WITH DUAL LIGHT**

The dual light polariscope will help to identify double refracting stones and to distinguish between many genuine gemstones and their simulants. It has transmitted illumination for the polariscope and side illumination that can be used as a light source for refractometers. Comes complete with a conoscope and AC adapter.



Order #	Description	1+
26-2603	Polariscope	\$98.00

**PORTABLE POLARISCOPE**

Easy-to-carry polariscope tests single or double refraction, optical properties, and pleochroism of gemstones. Comes with carrying pouch and flashlight.



Order #	Description	1+
26-2602	Polariscope	\$55.00

**FOLDING POLARISCOPE**

The folding polariscope is perfect for travel. It is easy to use with a microscope or any other light source.



Order #	Description	1+
26-2600	Polariscope	\$38.00

**DENSITY DIFFRACTION GRATING SPECTROSCOPE**

Compact unit produces clear bright spectra with low-intensity light. Pocket-sized spectroscope has fixed focus and slit.



Order #	Description	1+
29-3005	Spectroscope	\$115.00

**CALCITE DICHROSCOPE**

Determine if a stone is singularly or doubly refractive. Simultaneously view a gem's pleochroic colors in sharp contrast. Includes protective leather carrying case.



Order #	Description	12+	6+	1+
29-3002	Calcite Dichroscope	\$58.52	\$61.97	\$68.85



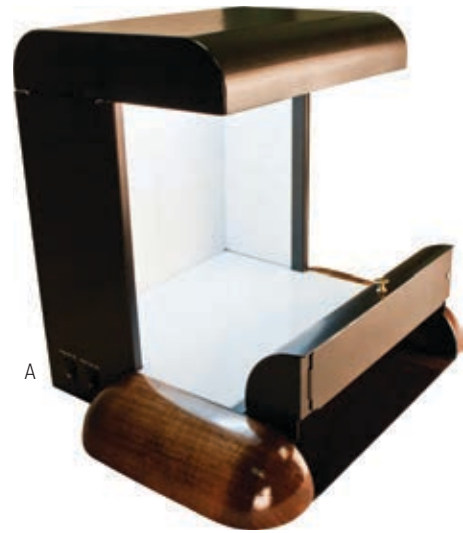

**DAZOR® SPECTROWAVE COLOR GRADING CABINET**

The Spectrowave Color Grading Cabinet by Dazor combines a traditional northern daylight fluorescent bulb grading box with a short-and-long wave ultra-violet (UV) fluorescence detection box into a single grading cabinet for professional gemologists to grade diamonds gemstones or pearls consistently. The traditional unfiltered daylight fluorescent bulbs have a spectrum which produces a constant standard illumination containing a portion of UV energy corresponding to that of natural daylight. Diamonds, gemstones, and pearls can be graded in this energy environment or under the influence of visible spectrum alone by hand-installing an anti-UV polycarbonate filter opaque to wavelengths below 390 nanometers. Additionally, Spectrowave has an optically diffused, dimmable, solid-state light engine. It emits a smooth 5,000° K white light with no UV energy. This may also be used to grade in the visible spectrum only. By removing the optical diffuser, the LED engine provides an excellent illumination tool. Diamond Grading Tray (Sold separately) provides for master stone comparison

Order # 13-1699

Item	Description	1+
A	Black and Mahogany Wood	\$1,412.25
	Mahogany Wood	\$1,343.57
	Natural Wood	\$1,343.57



**DIAMOND GEM LIGHT**

Lightweight and compact but big enough for the professional to grade diamonds and colored stones, this light features a Verilux and UV long-wave light, has a deep grading cavity, and makes grading diamonds and detecting fluorescence in colored stones a breeze with a 90% cool white background. Gem light comes with a protective case, diamond cloth, and bulbs. Requires four AA batteries (not included).

Order #	Description	12+	6+	1+
13-1708	Gem Grading Light	\$84.32	\$89.28	\$99.20

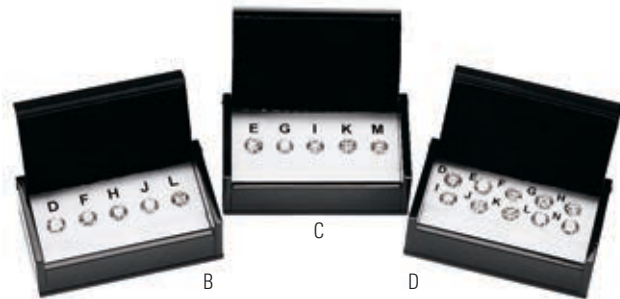

**CZ MASTER COLOR SET**

These CZ Master Sets have superior color accuracy and are hand graded against GIA® color master diamonds. All CZs in the set fall within the first half of the color grade and give equal spacing between color grades. All CZs are .80-1 carat diamond equivalent. Each set comes with a five-year manufacturer's warranty against color change.

Item	Order #	Description	1+
B	29-2710	5-Stone Set: D, F, H, J, L	\$318.95
C	29-2711	5-Stone Set: E, G, I, K, M	\$318.95
D	29-2712	10-Stone Set: D, E, F, G, H, I, J, K, L, N	\$498.00



**GEMORO® CZ MASTER SET PRO**

Professionally color grade diamonds in seconds. Each stone in the set is treated with GemOro's COLORLAST Technology to ensure permanent color saturation. It is expertly hand graded to master diamond color standards using the GIA® grading scale.

Order #	Description	12+	6+	1+
29-2714	10 Stone: 1 carat: E, F, G, H, I, J, K, L, M, N	\$364.65	\$386.10	\$429.00
29-2713	10 Stone: ½ carat: E, F, G, H, I, J, K, L, M, N	\$254.15	\$269.10	\$299.00

**MULTI GEMSTONE LIGHT**

This LED Gemstone Light has a multi-touch base, offering adjustable lighting effects for jewelry, diamond, jadeite, and gemstone. Arm is adjustable.

Order #	Description	1+
13-1724	Gemstone Light	\$141.35



**GEMORO® HORIZON LED DAYLIGHT DIAMOND COLOR GRADING LAMP**

This 6000K full spectrum natural daylight illumination task lamp with UV-free natural daylight illumination features a sleek, flexible, ergonomic design with superior LED lighting and is perfect for jewelers, artists, hobbyists, students, and more. Features a touch sensor, power switch, dimmer, and a USB port for charging smartphones, ipods, etc. Fully adjustable light angles and multi-voltage adaptor

Item	Order #	Description	12+	6+	1+
A	13-1723	Black LED Task Lamp	\$59.46	\$62.96	\$69.95
B	13-1723	Slate LED Task Lamp	\$59.46	\$62.96	\$69.95



**PORTABLE FOLDING LAMP**

This is a reasonably priced, portable folding light with a 13-watt daylight bulb.

Item	Order #	Description	12+	6+	1+
C	13-1701	Black Folding Lamp	\$22.48	\$23.81	\$26.45
D	13-1709	Replacement Bulb	\$4.34	\$4.59	\$5.10



**DIAMOND INSCRIPTION VIEWER COMBO**

This inscription loupe allows the user to view the certified number or information inscribed on the girdle of a diamond ring. It can also be used for loose stones with the aid of a stone holder or tweezers. The 20x triplet lens makes it easy to see the girdle of the stone. The swiveling pad allows you to view the ring in any direction.

Order #	Description	1+
26-2601	Inscription Reader	\$57.00





**CHELSEA COLOUR FILTER™ EMERALD LOUPE**

Helpful for identifying certain red, blue, and green stones, use this loupe to determine if a stone is natural or synthetic. Can also use to detect synthetic blue spinel and dyes in certain gems. Made in England.

Order #	Description	12+	6+	1+
<b>29-6505</b>	Chelsea Colour Filter™ Emerald Loupe	\$30.18	\$31.95	\$35.50



**LED FLASH LOUPE**

This loupe is easy to use and features 10X magnification of a 27 millimeter lens. LED light provides a clear view anywhere.

Order #	Description	Magnification	12+	6+	1+
<b>29-2505</b>	LED Flash Loupe	10X	\$25.46	\$26.96	\$29.95



**LED LIGHT FLOOX**

New LED penlight has natural color close to day-light which is very important to check the color of gemstones. Exclusive penlight with proper light brightness and color, 20 Lumens.

Order #	Description	12+	6+	1+
<b>80-0005</b>	LED Light Floox	\$29.16	\$30.87	\$34.30



**UV POCKET LIGHT**

This key chain UV light is a great gift and also a perfect travel tool. Includes a key ring attached to UV light.

Order #	Description	12+	6+	1+
<b>80-0004</b>	UV Pocket Light	\$8.54	\$9.05	\$10.05



**OPTICON FRACTURE SEALER**

The standard sealer for sealing stone fractures, this sealer is highly effective in penetrating surfaces. Depending on the stone and mineral content, some of the fractures will not permit an invisible seal.

Order #	Description	12+	6+	1+
<b>26-6008</b>	Opticon Fracture Sealer	\$16.02	\$16.97	\$18.85

**DIAMOND SHOVELS**

Use for scooping and handling stones.

Item	Order #	Description	W×L	12+	6+	1+
A	<b>51-0950</b>	Nickel-Plated Chrome	1¾"×3"	\$3.32	\$3.51	\$3.90
B	<b>51-0951</b>	Square Chrome-Plated	2⅞"×3⅞"	\$2.13	\$2.25	\$2.50
C	<b>51-0952</b>	Black Finish	1¾"×3"	\$2.93	\$3.11	\$3.45

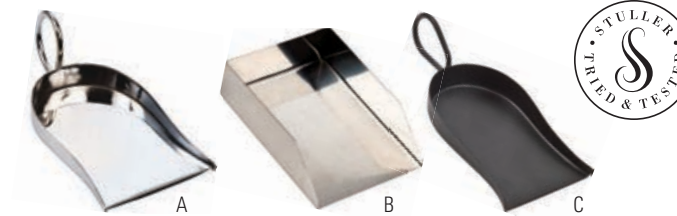

**SORTING TRAYS**

Grooved trays are used for sorting pearls, stones, and findings. Also has round indentations for size sorting as well.

Item	Order #	Description	W×L	12+	6+	1+
D	<b>38-1003</b>	Black Sorting Tray	7"×3 3/4"	\$4.44	\$4.82	\$5.35
E	<b>38-1002</b>	White Sorting Tray	7"×3 3/4"	\$4.44	\$4.82	\$5.35

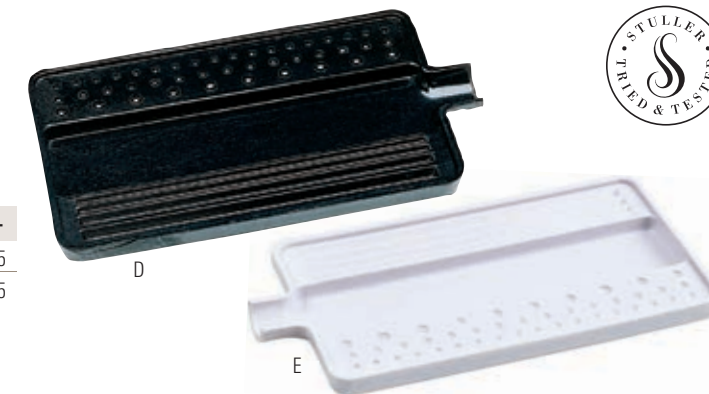

**STONE SORTING TRAY**

Use for sorting stones by size. Has grooves of various sizes for easily sorting stones. Made of solid, tough, unbreakable plastic.

Order #	Description	W×L	12+	6+	1+
<b>38-1000</b>	Stone Sorting Tray	8½"×5½"	\$4.92	\$5.14	\$5.35



**GEM PAPER TRAYS**

Ultra white trays come flat and are scored for easy folding. High quality and a true white makes them perfect for sorting and grading diamonds or other gemstones.



Item	Order #	Description	W×L	12+	6+	1+
F	<b>61-0547</b>	Small Paper Tray	2¾"×1⅞"	\$4.16	\$4.40	\$4.89
G	<b>61-0548</b>	Large Paper Tray	5"×1⅞"	\$5.35	\$5.66	\$6.29



**DISPLAY RINGS**

Use to display diamonds and other precious stones. Provides a secure way to present loose stones to customer. Excellent sales aid.

Item	Order #	Description	12+	6+	1+
H	<b>61-3000</b>	Small Gold Ring Display	\$2.93	\$3.11	\$3.45
J	<b>61-3010</b>	Small Silver Ring Display	\$2.93	\$3.11	\$3.45
K	<b>61-3020</b>	Large Gold Ring Display	\$2.93	\$3.11	\$3.45
L	<b>61-3030</b>	Large Silver Ring Display	\$2.93	\$3.11	\$3.45





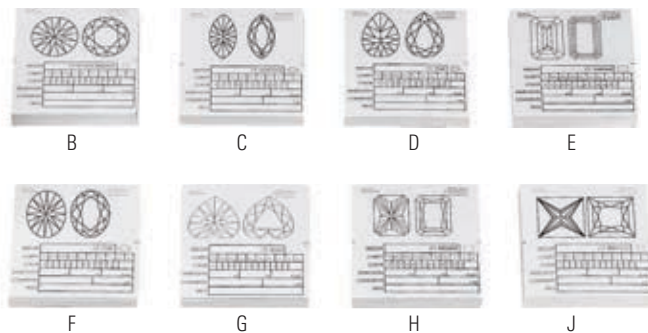

**DIAMOND INFORMATION FACT LABELS**

Diamond information fact labels are applied to diamond papers for quick and exact reference to the grade of the stones. The two-fold labels have both views of a diamond table up and table down, for plotting inclusions, carbon, and other identifying features. Self-adhesive label has a chart for listing weight, clarity, color, dimensions, comments, and prices. Individual shapes are sold in packs of 50. Assortment contains one pack of each shape.



Item	Order #	Description	WxL	12+	6+	1+
A	62-1240	8 Pack Assortment	3"x3"	\$26.34	\$27.89	\$30.99
B	62-1241	Round	3"x3"	\$10.19	\$10.79	\$11.99
C	62-1242	Marquise	3"x3"	\$10.19	\$10.79	\$11.99
D	62-1243	Pear	3"x3"	\$10.19	\$10.79	\$11.99
E	62-1244	Emerald	3"x3"	\$10.19	\$10.79	\$11.99
F	62-1245	Oval	3"x3"	\$10.19	\$10.79	\$11.99
G	62-1246	Heart	3"x3"	\$10.19	\$10.79	\$11.99
H	62-1247	Radiant	3"x3"	\$10.19	\$10.79	\$11.99
J	62-1248	Princess	3"x3"	\$10.19	\$10.79	\$11.99



**DIAMOND FACT SHEET**

Professional looking diamond sheet works well for notating comments regarding the stones.



Order #	Description	WxL	12+	6+	1+
61-1649	Diamond Fact Sheet (100 sheets)	8½"x11"	\$14.44	\$15.29	\$16.99



**APPRAISAL FORMS WITH ENVELOPES**

These triple forms allow for individual copies for record keeping and customers. Pack of 50.



Item	Order #	Description	WxL	12+	6+	1+
K	61-1710	Appraisal Forms with Envelopes (Box of 50)	8½"x11"	\$26.91	\$28.08	\$29.25

**APPRAISAL FORMS**

These triple forms allow for individual copies for record keeping and customers. Pack of 100.



Item	Order #	Description	WxL	12+	6+	1+
L	61-1655	Appraisal Form (Pack of 100)	8½"x11"	\$24.15	\$25.20	\$26.25

**STONE PAPERS**

European-style quality papers. Folded size measures 3½" x 1¾" (sold in packs of 25).



Item	Order #	Description	Color	12+	6+	1+
A	61-0517	Diamond	Blue/Blue	\$5.35	\$5.66	\$6.29
B	61-0518	Diamond	Blue/White	\$5.35	\$5.66	\$6.29
C	61-0519	Diamond	White/White	\$5.52	\$5.84	\$6.49

**GEMSTONE PAPERS**

Item	Order #	Description	Color	12+	6+	1+
D	61-0535	Sapphire	Double White/White	\$2.97	\$3.14	\$3.49
E	61-0536	Opal	Double Black/Black	\$3.05	\$3.23	\$3.59
F	61-0537	Ruby	Double Yellow/Yellow	\$2.97	\$3.14	\$3.49
G	61-0538	Emerald	Single Yellow	\$2.97	\$3.14	\$3.49

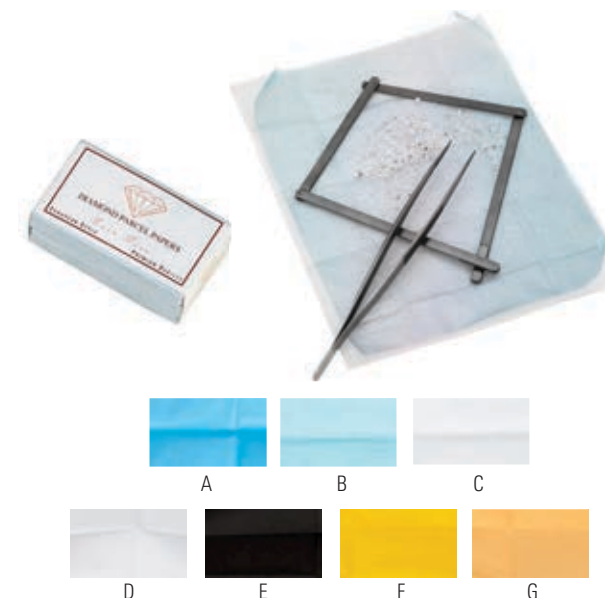

**DIAMOND & GEMSTONES SUPPLIES**

Heavy Paper Weight (folds up when not in use) 6 inch

Item	Order #	Description	WxL	12+	6+	1+
H	62-0040	6" Diamond Paper Weight	6"x6"	\$4.24	\$4.49	\$4.99
J	62-0044	Sorting Pad with White Paper and Heavy Cardboard Backing (50 sheets)	10"x12"	\$10.70	\$11.33	\$12.95

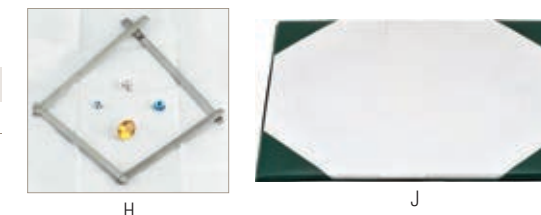

**GEMSTONE PARCEL BOXES AND WALLETS**

K. Single row, black leatherette stone parcel box with soft-suede interior and removable inserts

L. Stone parcel box with soft-suede interior and removable inserts

M. Leather stone parcel box with zipper closure

N. Soft black stone parcel pouch/wallet with zipper closure.

Item	Order #	Description	WxLxH	12+	6+	1+
K	61-0552	Single Row Black Leatherette	4¼"x10¼"x3"	\$27.63	\$29.25	\$32.50
L	61-0554	Double Row Black Leatherette	8"x12¾"x2¾"	\$36.98	\$39.15	\$43.50
M	61-0540	Leather Stone Parcel Box	7"x3½"x2¼"	\$14.66	\$15.53	\$17.25
N	61-0544	Soft Black Pouch	6"x3½"x1½"	\$13.39	\$14.18	\$15.75





# HAMMERS

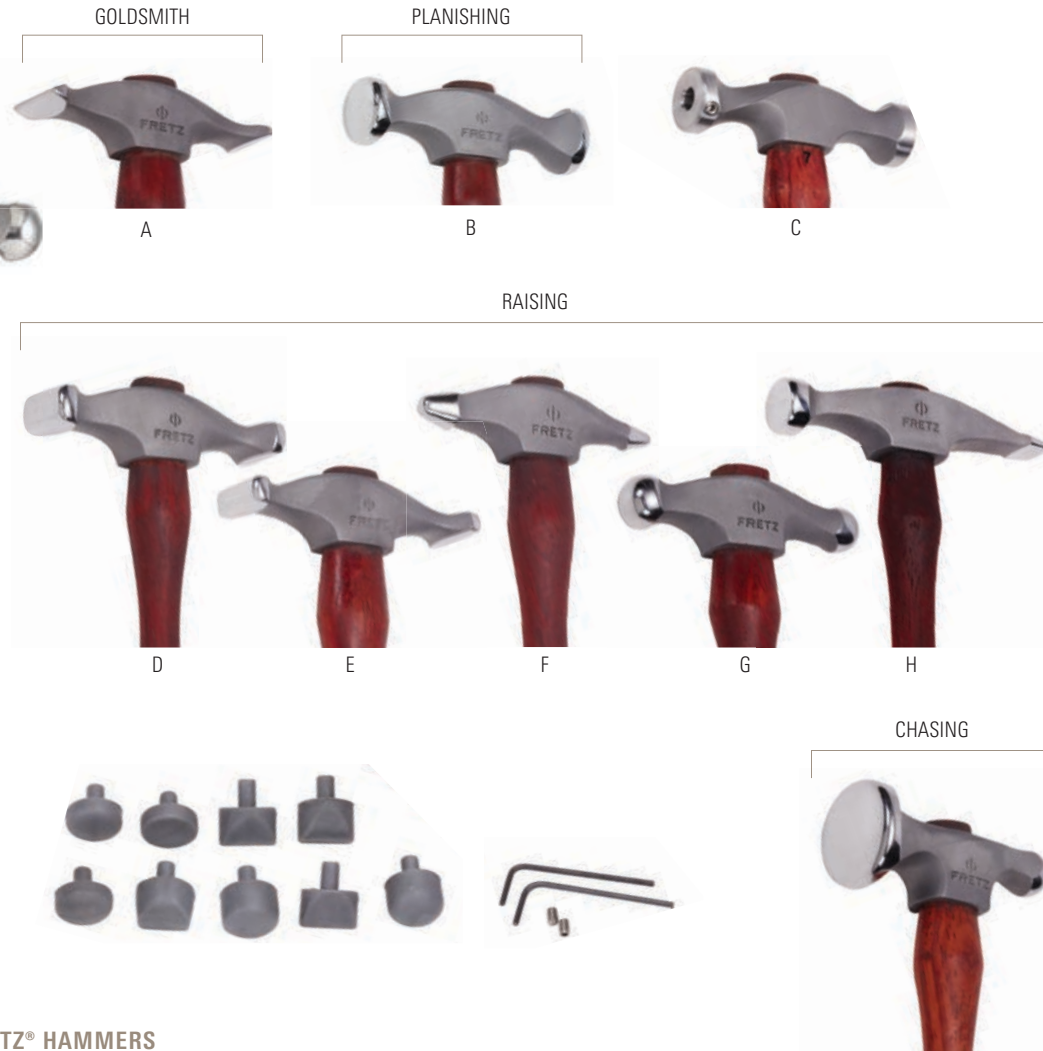

### FRETZ® HAMMERS

Fretz® Hammers feature beautiful and strong Padauk wood handles, oil finished and tapering to a slender neck for J flexibility. The head is cast from 420-grade stainless steel and hardened to 50HRC for maximum durability. Faces are polished to a mirror shine.

Item	Order #	Description	Length	Head Size	12+	6+	1+
A	37-1606	Hmr-12 Fretz Sharp Texturing Raising Hammer	9"	3x19, 1.5x19mm	\$45.99	\$48.69	\$54.10
B	37-1600	Hmr-1 Fretz Planishing Hammer	9"	19mm	\$45.99	\$48.69	\$54.10
C	37-1605	Hmr-7 Fretz Jewelers Planishing Hammer With 9 Plastic Inserts	9"	72mm	\$66.30	\$70.20	\$78.00
D	37-1601	Hmr-2 Fretz Wide Raising Hammer	9"	11x9, 8x19mm	\$45.99	\$48.69	\$54.10
E	37-1602	Hmr-3 Fretz Narrow Raising Hammer	9"	7x19, 3x19mm	\$45.99	\$48.69	\$54.10
F	37-1604	Hmr-5 Fretz Small Embossing Hammer	9"	5,7mm	\$45.99	\$48.69	\$54.10
G	37-1603	Hmr-4 Fretz Large Embossing Hammer	9"	12, 16mm	\$45.99	\$48.69	\$54.10
H	37-1608	Hmr-21 Fretz Goldsmithing Hammer	11.25"	17mm	\$45.99	\$48.69	\$54.10
J	37-1607	Hmr-17 Fretz Chasing Hammer	9"	22mm	\$48.62	\$51.48	\$57.20

### BENCH ANVILS

Item	Order #	Description	Diameter	12+	6+	1+
A	37-1552	Flat	2 3/4"	\$62.77	\$66.47	\$73.85
B	37-1553	Low Dome	2 3/4"	—	—	\$58.34
C	37-1554	Medium Dome	2 3/4"	\$62.77	\$66.47	\$73.85
D	37-1555	High Dome	2 3/4"	\$62.77	\$66.47	\$73.85



### FRETZ® 100 SERIES STAKES

Order #	Model	Description	Length	12+	6+	1+
37-1624	M-102	Fretz Low Dome Mushroom Stake	1.3"	\$30.60	\$32.40	\$36.00
37-1625	M-103	Fretz Flat Mushroom Stake	1.3"	\$28.90	\$30.60	\$34.00
37-1626	M-104	Fretz Large Concave Stake	2.2"	\$49.30	\$52.20	\$58.00
37-1627	M-105	Fretz Medium Concave Stake	1.8"	\$43.35	\$45.90	\$51.00
37-1628	M-107	Fretz Extra Concave Cone Stake	2"	\$66.30	\$70.20	\$78.00
37-1629	M-108	Fretz Slope Large Concave Stake	2"	\$53.55	\$56.70	\$63.00
37-1630	M-110	Fretz Sloped Convex Cone Stake	2"	\$68.85	\$72.90	\$81.00
37-1631	M-112	Fretz 30mm Convex Cuff Stake	1.2"	\$54.40	\$57.60	\$64.00
37-1632	M-113A	Fretz 20mm Convex Cuff Stake	1.4"	\$36.55	\$38.70	\$43.00
37-1633	M-113B	Fretz 20mm Convex Cuff Stake	1.4"	\$36.55	\$38.70	\$43.00
37-1634	M-117	Fretz Flat Cuff Stake	2.1"	\$84.15	\$89.10	\$99.00
37-1635	M-118	Fretz Flat Cuff Stake	2.1"	\$78.20	\$82.80	\$92.00
37-1636	M-122	Fretz Shallow Concave Stake	2.75"	\$48.45	\$51.30	\$57.00
37-1637	M-123	Fretz Minimal Concave Stake	2.75"	\$48.45	\$51.30	\$57.00
37-1623		Fretz Holder		\$46.75	\$49.50	\$55.00

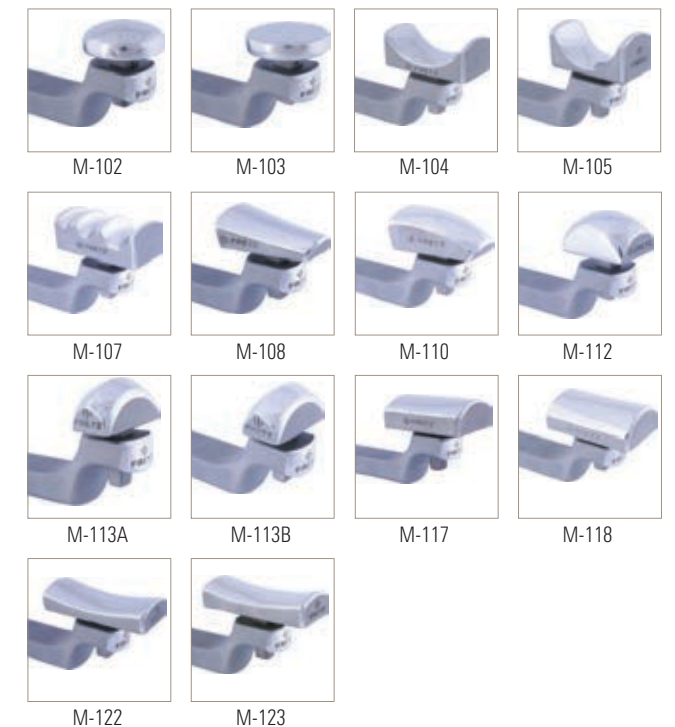

Holder

All items are priced at jeweler's cost, are sold each, unless otherwise noted, and are subject to change without notice. Visit [Stuller.com](http://Stuller.com) for our complete product selections, current pricing, and quantity price breaks. | 321





R-1



R-2

**FRETZ® HOLLOW RING STAKES**

The R-1 and R-2 are raising stakes used to create bezels and stretch metal to fit custom stones.

Order #	Model	Description	1+
37-1613	R-1	Fretz Standard Raising Stake	\$45.00
37-1614	R-2	Fretz Tapered Rounded Raising Stake	\$45.00



F-1



F-2

**FRETZ® FORMING STAKES**

- The F-1 is a stake that allows you to expand your forming and shaping skills. With this beak stake, you can roll the edge of a cone or tube shape inward and make a slightly tapered end.
- The F-2 is a double convex stake that will allow you to build your forming and shaping skills by allowing you to create domes. On the larger end of the stake, you can create bold curved shapes. The smaller end allows you to create smaller radius shapes.
- The F-3 is a doming stake and is used to form bezels, make hollow rings, or perform any type of smithing that you could do with larger stakes but on a smaller scale.
- The F-6 is a shell stake that allows you to increase your forming and shaping skills. This shell stake is used for bracelet-sized work. Using this stake, you can form dramatic concave shapes and small convex shapes.
- The F-8 is a horn stake that allows you to increase your forming and shaping skills. You can create a domed shape. Use to make hollow rings and large beads for tubing.
- The F-9 is a convex/concave stake that allows you to increase your forming and shaping skills. The curved end of this stake will give you a more subtle curve, and the concave end forms more concave shapes on cylinders and bracelets.

Order #	Model	Description	1+
37-1615	F-1	Fretz Beak Stake	\$54.00
37-1616	F-2	Fretz Double Convex Stake	\$54.00
37-1617	F-3	Fretz Doming Stake	\$54.00
37-1618	F-6	Fretz Shell Stake	\$54.00
37-1619	F-8	Fretz Horn Stake	\$54.00
37-1620	F-9	Fretz Convex/Concave Stake	\$54.00



F-3



F-6



F-8



F-9



F-2A



F-2B

**FRETZ® PROGRESSIVE STAKES**

Fretz® forming stakes have progressively sharper angles, enabling you to make fluted designs.

Order #	Model	Description	1+
37-1621	F-2A	Fretz Convex Fluting Rolled Edge	\$54.00
37-1622	F-2B	Fretz Convex Fluting Medium/Sharp	\$54.00

**FRETZ® DVD AND TOOLS SET**

Fretz® DVD and tools set is an amazing buy for your bench. This is a top-quality professional tools kit that can last a lifetime. This set gives you everything you will need for your top-quality jewelry making needs.

Included in this set-

- Jeweler's planishing hammer HMR-1; 88g head
- Jeweler's wide raising hammer HMR-2; 85g head
- Jeweler's narrow raising hammer HMR-3; 78g head
- Jeweler's double-ended hammer with inserts HMR-7
- Jeweler's rounded narrow raising hammer HMR-8
- Jeweler's rounded wide raising hammer HMR-9
- Steel stake holder H-1
- Double convex forming stake F-2; 75 x 14.5mm
- Convex lining fluting stake F-2A
- Convex sharp fluting stake F-2B
- Convex extreme sharp fluting stake F-2C
- Shell forming stake F-6; 97 x 15mm
- Convex/concave forming stake F-9; 77 x 13mm

Also included is the 90-minute DVD *Metalsmith Essentials: Basic Jewelry Hammering and Forming* with Bill Fretz. This DVD puts the expertise of renowned metalsmith and tool designer Bill Fretz right in your reach. You can learn from the ground up, starting with basic convex and concave forming techniques and continuing through eight lessons to begin mastering techniques such as planishing, raising, using stakes to form and flute metal, and many others. This is a set you want to have for all of your jewelry making needs.



Order #	Description	12+	6+	1+
37-1638	Fretz DVD Set 1 & Tools	\$637.50	\$675.00	\$750.00

**FRETZ® FRETZ® FORMING STAKES**

The Fretz® #5 Forming Stake Set is a group of stakes used for metal forming. They are similar to silversmithing stakes but on a jewelry-size scale.

Order #	Description	12+	6+	1+
37-1643	Forming Stake #5	\$327.25	\$346.50	\$385.00



**RAISING HAMMER**

These hammers are made of Delrin®, a long-lasting, non-marring material, perfect for forming and shaping non-ferrous metals. With its dead blow design, there is little to no recoil when you strike, making it easy to use for long periods of time. Made in the USA

Item	Order #	Description	Length	Head Size	1+
A	37-5401	Round	10½"	1¼"	\$50.95
B	37-5400	Flat	10½"	1¼"	\$50.95

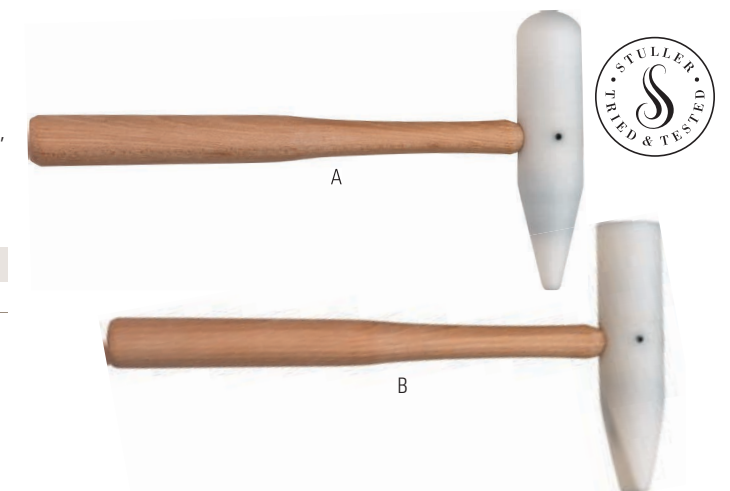



**GRS® CHASING HAMMER**

These hammers are made from carefully heat-treated, high-alloy tool steel. The heads have a rich black-oxide color treatment applied, and then each end is beautifully hand polished. The hardwood handles are made from carefully selected wood that is superior to the wood used on lower quality hammers. The balance and fine craftsmanship of these chasing hammers add precision and satisfaction to your work.

**Order # 37-03630**

Item	Description	Length	Head Size	1+
A	Flat	8"	½ x 1"	\$45.10
B	Round	8"	½ x 1"	\$45.10

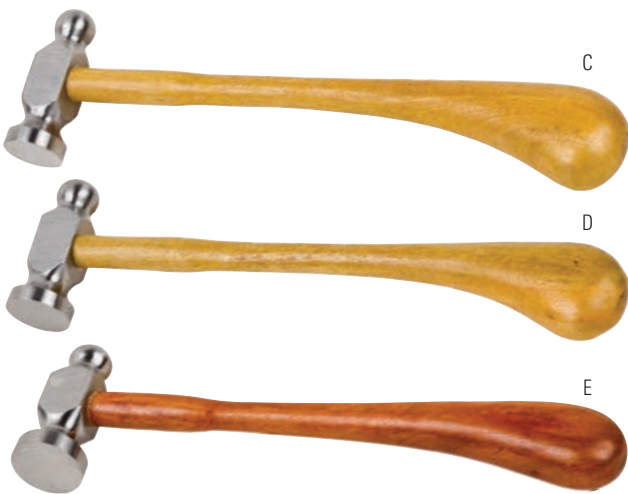

**CHASING HAMMER**

Designed for silversmiths and arts and crafts work, the flat head is used to flatten, shape, and form objects to strike chasing tools. The round end is used for forming decorative patterns and designs. Made with hardwood handles, this hammer features a forged head which is wedge mounted.

**Order # 37-03650**

Item	Description	Length	Head Size	1+
C	Chasing Hammer	10"	1"	\$14.30
D	Chasing Hammer	10"	1 1/8"	\$15.40
E	Chasing Hammer	10"	1 1/4"	\$16.50

Replacement Chaser Hardwood Handles

**Order # 37-04100**

Pistol Handle	10"	\$5.70
Round	10"	\$6.05
Oval	10"	\$7.45



**TEXTURING HAMMER**

With this hammer, the possibilities for patterns are endless. Never before has a hammer been designed to do so much. Use the small designs to pinpoint texture in a certain area and the large designs to cover a bigger area. Or use multiple tips to layer textures over one another. Each tip is easily and securely attached with a threaded collar. The tips are approximately 3/4" with various textures.

Order #	Description	Length	Head Size	1+
<b>37-2169</b>	Hammer with 9 Faces	9 1/2"	1/2"	\$47.35

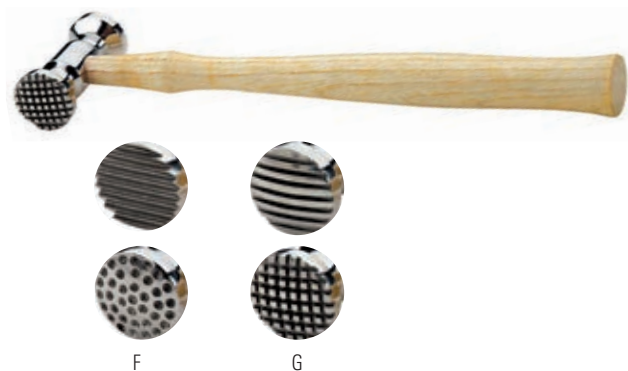

**TEXTURING HAMMER**

These texturing hammers are for non-ferrous metals. Double-sided, they enable the user to make attractive patterns to give jewelry and other metal items a unique look. Two different patterns on each side.

Item	Order #	Description	Length	Head Size	1+
F	<b>37-2170</b>	Sharp Stripe and Dimples	10"	2 1/2 x 1 1/8"	\$20.70
G	<b>37-2171</b>	Checkered and Wide Stripe	10"	2 1/2 x 1 1/8"	\$20.70

**MALLETS WITH DETACHABLE FACES**

Faces can be changed to provide any combination desired. Faces can also be replaced when worn. Sold with two different faces and a wrench to tighten or remove collars. Faces are brass and nylon.

**Order # 37-53600**

Item	Description	Length	Head Size	1+
A	2 1/2 oz Mallet	9"	2"	\$13.60
B	4.2 oz Mallet	9"	2 3/4"	\$17.60

REPLACEMENT FACES

**Order # 37-55000**

Item	Description	Head Weight	1+
C	Nylon	.06 oz	\$1.45
D	Brass	.4 oz	\$1.45
E	Nylon	.09 oz	\$1.45
F	Brass	.6 oz	\$1.70

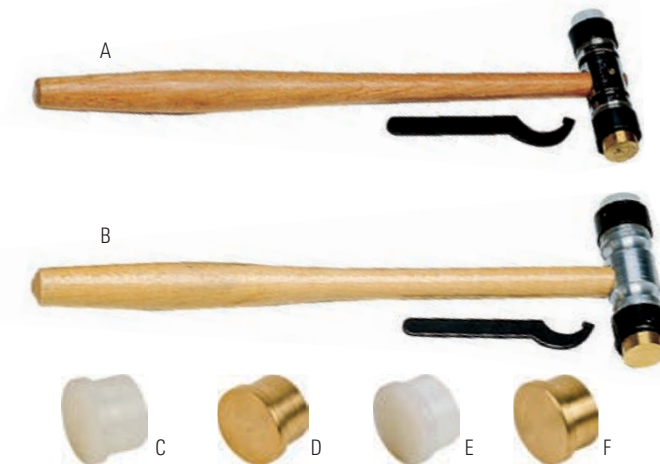

**NYLON HAMMER**

Seasoned ash handle with a drop-forged head and two nylon faces. Measures 1 1/8" (27mm). Faces can be removed with a half-turn. Made in Germany.

Order #	Description	Length	Head Size	1+
<b>37-5310</b>	Nylon Hammer	10"	1 1/8"	\$14.10



**BRASS HAMMER**

With a sturdy hardwood handle, this hammer will provide years of service.

Order #	Description	Length	Head Size	1+
<b>37-5300</b>	Brass Hammer	10"	1 1/4"	\$8.15



**BRASS HAMMER**

Soft, yellow brass heads and cushioned rubber grips offer non-marring striking on all metal surfaces, perfect for stamping, dapping, chasing, using with design stamps, and using with disc cutters.

**Order # 37-53200**

Item	Description	Length	Head Size	1+
G	1 lb Brass Hammer	9"	3/4"	\$26.45
H	2 lb Brass Hammer	9"	1 1/16"	\$39.95







**GARLAND RAWHIDE MALLETS**

Heads are made of the finest quality, specially treated rawhide, which will not mark or scar metal. Handles are made of hardwood. Made in the USA.

**Order # 37-70000**

Item	Description	Length	Head Size	1+
A	2 oz Mallet	10"	1"	\$15.50
B	4 oz Mallet	9"	1¼"	\$17.60
C	6 oz Mallet	9"	1½"	\$20.70
D	9 oz Mallet	9"	1¾"	\$22.80
E	11 oz Mallet	9"	2"	\$25.90

**PLASTIC MALLET**

Made of durable, non-porous plastic with hardwood handle. This easy-to-clean mallet features non-marring plastic that cushions the shock at impact. Has the bounce back similar to a rawhide mallet.

**Order # 37-70700**

Description	Length	Head Size	1+
6 oz Mallet	9"	1½"	\$10.35
9 oz Mallet	9"	1¾"	\$15.30
14 oz Mallet	9"	2½"	\$16.40

**Order # 37-21600**

**RIVETING HAMMER**

Use for forming, riveting, and tacking. One end is flat, and the other is chisel shaped. The drop-forged, polished head is mounted on a select hardwood handle. Face diameter ½".

Item	Order #	Description	Length	Head Size	1+
F	37-2160	4 oz Riveting Hammer	9"	½"	\$32.35
G	37-2180	5 oz Riveting Hammer	9"	½"	\$35.85

**ROUND-FACE RIVETING HAMMER**

One end is flat for general purpose, and the other end is chisel shaped for spreading rivet heads. Round ¾" face diameter. Made in Germany.

Order #	Description	Length	Head Size	1+
37-2150	Riveting Hammer	9"	¾"	\$25.25

**MASTER QUALITY BALL PEEN HAMMER**

Use for flattening, shaping, or removing dents. Made of high-carbon steel, this hammer provides extra strength for driving chisels, punches, and other tools.

**Order # 37-12020**

Item	Description	Length	Head Size	1+
A	2 oz Peen Hammer	10"	2"	\$22.05
B	4 oz Peen Hammer	10"	2½"	\$22.05



**GOLDSMITH HAMMER**

Use for working on rings for sizing. The head has one round/flat end (5/8" diameter) and one chisel-shaped end. The hammer features a sturdy hardwood handle.

Order #	Description	Length	Head Size	1+
37-0409	4 oz Hammer	11½"	2½"	\$34.80



**PLANISHING HAMMERS**

These planishing hammers are ideal for smoothing out imperfections and finishing surfaces that have been raised.

- C. • Length: 4 ¾" (111mm) • Weight: 14 oz • Small End: 1" (25mm) • Large End: 1½" (29mm)
- D. • Length: 3" (76mm) • Weight: 7 oz • Small End: 1½" (24mm) • Large End: 1" (25mm)

Item	Order #	Description	Length	Head Size	1+
C	37-1240	Hammer	4¾"	½ x 1"	\$55.70
D	37-1241	Hammer	3"	1¼"	\$55.70



# LAMPS AND LIGHTBOXES



On/Off Switch

A

### DAZOR® THREE-BULB BENCH LAMP

Dazor's 45W Fluorescent Series provides abundant light over a large work area with the benefits of a stylish and energy-efficient design. These are considered the perfect upgrade to the Classic Dazor Fluorescent Series of task lights. Features—

- Provides abundant, even, and shadow-free light over a broad surface
- Features Dazor's patented floating adjustable arm for smooth and easy positioning of the lamp to any position for a total reach of 33 inches
- Fully enclosed counterbalance spring for dust-free operation and low maintenance
- State-of-the-art electronic ballast provides the highest energy-efficiency available on the market, instant on/off control of the bulbs, and the elimination of visible bulb strobing or flickering
- All-metal construction for rugged, heavy-use environments
- Sturdy mount can be clamped or bolted to a horizontal surface
- Durable powder-coated finish
- UL, CUL, CE
- Five year warranty
- Made in the USA

Order # 13-1791

Item	Color	Base Type	Arm Reach	1+
	Black	Clamp	33"	\$239.35
	Black	Clamp	43"	\$239.35
A	Gray	Clamp	33"	\$240.45
	Gray	Clamp	43"	\$239.35

### DAZOR® TWO-BULB BENCH LAMP

Dazor's 30W Fluorescent Series provides abundant light over a large work area with the benefits of a stylish and energy-efficient design. These are considered the perfect upgrade to the Classic Dazor Fluorescent Series of task lights. Features—

- Provides abundant, even, and shadow-free light over a broad surface
- Features Dazor's patented floating adjustable arm for smooth and easy positioning of the lamp to any position for a total reach of 43 inches
- Fully enclosed counterbalance spring for dust-free operation and low maintenance
- State-of-the-art electronic ballast provides the highest energy-efficiency available on the market, instant on/off control of the bulbs, and the elimination of visible bulb strobing or flickering
- All-metal construction for rugged, heavy-use environments
- Sturdy mount can be clamped or bolted to a horizontal surface
- Durable powder-coated finish
- UL, CUL, CE
- Five-year warranty
- Made in the USA

Order # 13-1790

Item	Color	Base Type	Arm Reach	1+
B	Black	Clamp	43"	\$217.30
	Gray	Clamp	43"	\$217.30

B

### DAZOR® FLOATING-ARM JEWELER'S LAMP

Dazor® tube lamps are supplied with 15-watt daylight tubes (6500°K) for a natural light. Your choice of two or three-tube models. The Dazor floating-arm is easily positioned with a touch of a finger and will stay where you put it without springs or tightening screws. Rugged all-metal construction has no exposed springs or wires. Now finished with a powder coating for years of lasting use. Available in several colors, desk base models, clamp models, and two arm lengths. Clamp models will also fit into our bench-friendly Bushing Mount (13-1823; sold separately). Tubes/bulbs not covered by five-year warranty.

Item	Order #	Color	Base Type	Arm Reach	1+
TWO TUBE LAMPS					
A	13-1802	Dove Gray	Desk Lamp	33"	\$243.65
B	13-1803	Black	Desk Lamp	33"	\$255.99
C	13-1801	Black	Clamp	43"	\$220.45
D	13-1800	Dove Gray	Clamp	43"	\$220.45
THREE TUBE LAMPS					
E	13-1808	Black	Desk Lamp	27"	\$275.26
	13-1821	Dove Gray	Clamp	33"	\$244.07
	13-1805	Dove Gray	Clamp	43"	\$237.25
	13-1806	Black	Clamp	43"	\$235.00



New power switch

### DAZOR® LED DIAMOND LIGHTS

These LED Diamond Lights are a combination of proven technology, cutting-edge research, and product development. Dazor's floating-arm lighting solutions have been the industry standard in the jewelry industry since 1938. Our use of advanced technology coats the ore boards with a ceramic material that naturally dissipates the heat; no irritating, noisy fans. UV wavelength has been limited from the LED light spectrum. The light pattern from Dazor's LED luminaire is diffuse and color consistent. The phosphorous coating used in the powerful 1/2W LED produces a single, white light. No striping, patterns of illumination blotches, nor color distortion are present in the pattern of illumination. One-year warranty

Item	Order #	Arm Type	Color	Base Type	Arm Reach	1+
F	29-4777	Classic Arm	Black	Clamp	41"	\$346.45
G	29-4778	Classic Arm	Black	Clamp	24"	\$346.45
H	13-1799	Flexible Arm	Black	Clamp	25"	\$168.42



G

H

F





Flexible gooseneck arm

**DAZOR® ECOFLEX**

The innovative new Wolf EcoFlex LED Bench Light by Dazor is rugged and environmentally friendly LED bench light. The sleek head rotates 340 degrees vertically and 90 degrees horizontally and features 7x1-Watt dimmable high brightness white LEDs optically mixed to produce an even light pattern. The 25-inch flexible arm exceeds the depth of most jewelry benches and allows you to aim the light exactly where you need it without the heat. The light features a grooved aluminum head design that removes heat and is comfortable to the touch. Dazor's clever thermal engineering allows the LEDs to achieve their rated life of 50,000 hours.

- Illumination is optically mixed for smooth, diffused light output
- Beam of light can be positioned directly where needed
- Long arm reach 25 inches (63cm) exceeds depth of any jewelry bench
- Splash guard to protect against debris and liquids
- Dimmable down to 25% of full intensity
- Grooved aluminum head removes heat; comfortable to touch

Order #	Description	1+
13-1798	LED Bench Light	\$209.95



Flexible gooseneck arm

**SATURN LED BENCH LIGHT**

The Saturn LED Bench light is the future generation in energy efficient lighting designed for years of use on the bench. Precision machined components house the latest high brightness LED technology that produces white light without heat or UV waves. The fixture has a velvety smooth on/off dimming control and remains cool to the touch after hours of uninterrupted use. Saturn is attached to a flexible gooseneck arm which can be mounted using a clamp that mounts to the back of your bench without drilling holes.

- Features —
- Optimal electrical and thermal design
  - Highest lumen efficiency available
  - 70,000 hour maintenance free operation
  - 22 degree beam spread provided
  - Universal low voltage 12V AC or DC
  - Stable in vibration environments
  - Rugged machined aluminum housing
  - Bench clamp option without drilling

Order #	Description	1+
13-1781	LED Bench Light	\$269.36



**DAZOR® HI-LIGHTER MAGNIFYING DESK LAMP**

Uses a 13-watt compact fluorescent tube (included) located behind the magnifying lens. The unique placement of the bulb casts light at an angle for highlighting object details. This unique shadowing feature makes details of uneven surfaces pop out to the viewer. This effect is well suited for precise details found in variations of an object's surface. The three-diopter (75% magnification) five-inch crown optical glass lens has a focal length of 13 inches. Rugged all-metal construction and a durable powder coating allows for years of lasting use. Clamp models will also fit into our bench-friendly bushing mount (13-1823, sold separately). Supplied with 13-watt daylight tube (6500°K). Tubes/bulbs not covered by five-year warranty.

Item	Order #	Description	1+
A	13-1818	Magnifying Clamp Base Lamp	\$248.75
B	13-1819	Magnifying Desk Base Lamp	\$280.28
C	13-1722	Replacement Bulb (13W-41-4PIN)	\$15.15

**DAZOR® FLUORESCENT BULBS**

Different types of lights are available in several different color temperatures to best fit your needs.

Item	Order #	Description	Color Range	Color Temp	1+
A	13-1824	Tube	Cool White	4,100° K	\$9.50
	13-1824	Tube	Daylight	6,500° K	\$10.55
	13-1824	Tube	Full Spectrum	5,500° K	\$21.20
	13-1810	Tube	Daylight	6,500° K	\$14.80
B	13-1820	U-Shape	Full Spectrum	5,000° K	\$18.05
	13-1820	U-Shape	Cool White	4,100° K	\$20.55



**DAZOR® MOUNTS**

Item	Order #	Description	Color	1+
C	13-1000	Ballast	—	\$17.55
D	13-1823	Bushing	Black	\$27.56
E	13-1825	Clamp Base	Dove Gray	\$44.42
	13-1826	Clamp Base	Black	\$44.42
F	13-1831	Horizontal Clamp	Dove Gray	\$32.20
	13-1831	Horizontal Clamp	Black	\$32.20
G	13-1833	Wall Mount/Table Base	Dove Gray	\$55.45
H	13-1834	Back Splash Clamp	Black	\$60.90
J	13-1792	Clamp Mount	—	\$56.70

**LED ACROBAT LAMP**

LED-Light Emitting Diode lamps are particularly suited for the reading of color and all its different shades and hues for shadow-free operation and sharp detail. This is made possible by the uniformed intensity of light and the color temperature of 5500°K corresponding to sunlight. Protecting our eyes from fatigue and against constant (and almost imperceptible) vibrations from the source of light is a duty we have towards ourselves, as is the need to read the whole color range in order to reproduce it simply and naturally. Power LED also saves energy by reducing the consumption of electricity throughout its working life of about 50,000 hours, the equivalent of six years nonstop use 24/7. LEDs do not generate infrared, UV radiation, or CO<sup>2</sup> and have a range of luminosity with an aperture of 120 degrees providing excellent wide viewing. Power LED lamps have an elegant design and are the evolution of Eco power 13: with adjustable multi-jointed arm and new screen distributing the light uniformly (over 120°). The intensity can be adjusted from 0 to 100% by a dimmer at the side of the lamp. All these features guarantee a different range of applications from jewelry to dentists. All lamps are sent in a single box including lamp support and power supply (dimension 84"x26"x18", gross weight 4.5 kg)

**Order # 13-1841**

Item	Description	1+
K	LED Lamp Acrobat	\$375.00
L	Clamp Support	\$12.00
M	Screw Support	\$12.00



Lamps and Lightboxes

Lamps and Lightboxes



**BENCH LAMP**

Suitable for workshop or desktop use. Three fluorescent bulbs provide ample illumination. The innovative design allows the user to raise lower or tilt directing the light source quickly and efficiently onto your work.

- 110v/60HZ
- 3 x 14W
- 14W T502

Order # 13-4300

Item	Description	1+
A	Bench Lamp	\$69.00
B	Replacement Bulb	\$7.05



**CIRCLINE MAGNIFIER**

Designed for shadow-free inspection, soldering, and assembly work. The three-diopter (75% magnification), five-inch crown optical glass lens has a focal length of 13 inches. Rugged all-metal construction and durable powder coat allows for years of lasting use. Clamp models will also fit into our bench-friendly bushing mount (sold separately). Supplied with 22-watt daylight tube (6500°K). Tubes/bulbs not covered by five-year warranty.

Order #	Description	Arm Extension	Lamp Base Type	1+
13-8122	Circline Magnifier Clamp Base	42	Clamp	\$243.34



**INSPECTION LAMP**

Illuminated magnifier provides hands-free viewing and allows you to see greater detail while reducing eye strain. This clamp-on lamp provides focal length and the three-diopter lens magnifies an object by 75%. The floating arm requires only a slight touch to raise, lower, or tilt. Supplied with a 22-watt circline fluorescent bulb.

Item	Order #	Description	Color Temperature	1+
C	13-2016	Inspection Lamp	6,500° K	\$48.15
D	13-8123	Replacement Bulb	6,500° K	\$21.20
	13-8123	Replacement Bulb	5,000° K	\$14.80

Clamp-on lamp

3-diopter lens magnifies an object by 75%

**MULTI GEMSTONE LIGHT**

This LED Gemstone Light has a multi-touch base, offering adjustable lighting effects for jewelry, diamond, jadeite, and gemstone. Arm is adjustable.

Order #	Description	1+
13-1724	Gemstone Light	\$141.35



touch screen display

**GEMORO® HORIZON LED DAYLIGHT DIAMOND COLOR GRADING LAMP**

This 6000K full spectrum natural daylight illumination task lamp with UV-free natural daylight illumination features a sleek, flexible, ergonomic design with superior LED lighting and is perfect for jewelers, artists, hobbyists, students, and more. Features a touch sensor, power switch, dimmer, and a USB port for charging smartphones, ipods, etc. Fully adjustable light angles and multi-voltage adaptor

Order # 13-1723

Description	1+
Black LED Task Lamp	\$69.95
Slate LED Task Lamp	\$69.95



touch display and USB port



**PORTABLE FOLDING LAMP**

This is a reasonably priced, portable folding light with a 13-watt daylight bulb.

Item	Order #	Description	1+
A	13-1701	Black Folding Lamp	\$26.45
B	13-1709	Replacement Bulb	\$5.10

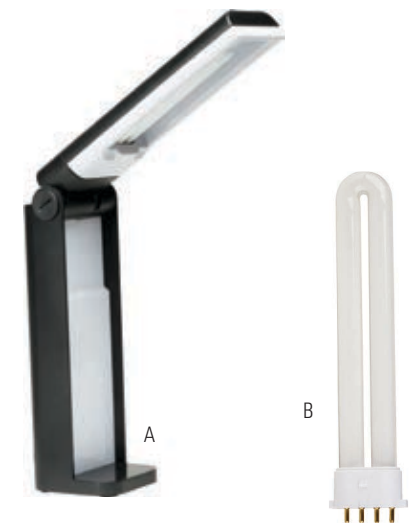





## Amplify Your Expertise

WITH STULLER CUSTOMIZATION SOFTWARE

At the bench, speed and beauty don't always go together. But integrating a CAD workflow can give you both. Getting more done is key to your success, and customization software can supercharge your existing skill set. Stuller offers the leading suite of jewelry design software programs in the business.

To learn about how Stuller can help you amplify your expertise, contact a customization expert at 800-357-6272 or visit [Stuller.com/CustomSolutions](http://Stuller.com/CustomSolutions).

### PHOTOGRAPHY BOX

Designed for use with consumer-oriented digital cameras this photo box puts the camera control in your hands. A single switch controls the two fluorescent 5500°K lights in the bottom and back. Bright white interior side panels and door provide the perfect reflective surfaces to complement the diffused lighting. Magnetically hinged door can easily be opened and removed. Creates a shadow-free wraparound lighting environment ideal for jewelry photography.

- Sturdy construction and compact size for portability
- Reflective lighting
- Flexible camera angles

Item	Order #	Description	Size	1+
A	13-2030	Mini Photo Box	10"	\$269.00
	13-2031	Small Photo Box	12"	\$295.00
	13-2032	Medium Photo Box	14"	\$498.00
	13-2033	Large Photo Box	16"	\$595.00



A

### CODA DIGITAL MAGNIFICATION AND INSPECTION SYSTEM

CODA combines a true high-definition 1080p resolution camera with Dazor's time-tested articulating arm. This streamlined system is designed to provide the ultimate in magnification simplicity for production and quality control inspection. Dazor's patented and familiar floating arm allows the user complete control over orienting the HD Camera into any desired position while minimizing the system's total footprint. No longer is it necessary to clutter valuable benchtop real estate with a heavy boom stand or other weighted base. CODA can be positioned to view objects at any distance (lens focuses to infinity) — magnification, working distance, and field view will vary with distance.

Order # 13-1901

Item	Description	1+
B	34" Arm/16mm Lens	\$995.00
	24" Arm/35mm lens	\$995.00
	34" Arm/35mm Lens	\$995.00
	24" Arm/16mm lens	\$995.00



B

### CODA LED MONITOR

CODA can be positioned to view objects at any distance (lens focuses to infinity) — magnification, working distance, and field view will vary with distance.

Order #	Description	1+
13-1902	21½" LED Monitor	\$295.00



### CODA HD VIDEO AND FRAME GRABBER

Save HD video and images directly to USB thumb drive (not included)

Order #	Description	1+
13-1903	HD Video and Frame Grabber	\$325.00





# LOUPES AND MAGNIFIERS



## SUPER LIGHTWEIGHT LOUPE

These super lightweight professional triplet loupes are made of anodized aircraft-grade aluminum alloy housing. Triplet lenses are made by cementing three lens elements to form one single lens for aplanatic and achromatic color corrections. Features a lens diameter of 21mm, 10X power, and a hexagonal-cut shape. Weighs 1.4 ounces.

Order # 29-6070

Item	Color	Power	Lens Diameter	12+	6+	1+
A	Red	10X	21mm	\$16.87	\$17.87	\$19.85
B	Gray	10X	21mm	\$16.87	\$17.87	\$19.85
C	Purple	10X	21mm	\$16.87	\$17.87	\$19.85
D	Blue	10X	21mm	\$16.87	\$17.87	\$19.85
E	Black	10X	21mm	\$16.87	\$17.87	\$19.85
F	Gold	10X	21mm	\$16.87	\$17.87	\$19.85



## LARGE HEX 10X LOUPE

These 10X triplet loupes offer a wide 21.5mm field of view. Case is hexagonal and the head is a 12-faceted design. Leather case included.

Order # 29-60470

Item	Color	Power	Lens Diameter	12+	6+	1+
A	Black	10X	21.5mm	\$14.15	\$14.99	\$16.65
B	Gold	10X	21.5mm	\$14.15	\$14.99	\$16.65
C	Silver	10X	21.5mm	\$14.15	\$14.99	\$16.65



## HEXAGON TRIPLET LOUPE

Three-piece bonded lenses. Comes with protective leather case.

Order # 29-26050

Item	Color	Power	Lens Diameter	12+	6+	1+
D	Gray	15X	20.5mm	\$19.85	\$21.02	\$23.35
E	Black	10X	20.5mm	\$13.56	\$14.36	\$15.95



## HASTINGS OVAL TRIPLET 10X LOUPE

These are high-quality Hastings Triplet Loupes. Hastings lenses are constructed from three lens elements cemented together to form a single lens. The unmatched clarity of these triplet loupes is further enhanced by black, outer lens edges, which eliminate color distortion. All loupes come in a hard leather case. Loupes are available in a variety of colors with or without a non-slip, rubber grip, also engravable. Lens diameter is 18mm.

Order # 29-60100

Item	Color	Power	Lens Diameter	12+	6+	1+
F	Pearl White	10X	18mm	\$13.47	\$14.27	\$15.85
G	Blue Lapis	10X	18mm	\$13.47	\$14.27	\$15.85
H	Green Malachite	10X	18mm	\$13.47	\$14.27	\$15.85
J	Black Marble	10X	18mm	\$13.47	\$14.27	\$15.85
K	Pink Marble	10X	18mm	\$13.47	\$14.27	\$15.85
L	Gold	10X	18mm	\$11.05	\$11.70	\$13.00
M	Black	10X	18mm	\$11.43	\$12.11	\$13.45
N	Chrome	10X	18mm	\$11.05	\$11.70	\$13.00



## HASTINGS HEXAGON TRIPLET 10X LOUPE

These are high-quality Hastings Triplet Loupes. Hastings lenses are constructed from three lens elements cemented together to form a single lens. The unmatched clarity of our triplet loupes is further enhanced by black, outer lens edges, which eliminate color distortion. All loupes come in a hard leather case. Loupes are available in a variety of colors with or without a non-slip, rubber grip. Lens diameter is 21mm.

Order # 29-6020

Item	Color	Power	Lens Diameter	12+	6+	1+
G	Pearl White	10X	21mm	\$19.42	\$20.57	\$22.85
H	Blue Lapis	10X	21mm	\$19.42	\$20.57	\$22.85
J	Green Malachite	10X	21mm	\$19.42	\$20.57	\$22.85
K	Black Marble	10X	21mm	\$19.42	\$20.57	\$22.85
L	Pink Marble	10X	21mm	\$19.42	\$20.57	\$22.85
M	Gold	10X	21mm	\$15.30	\$16.20	\$18.00
N	Black	10X	21mm	\$15.30	\$16.20	\$18.00
P	Chrome	10X	21mm	\$15.30	\$16.20	\$18.00



## HASTINGS TRIPLET 20X LOUPE

Order # 29-60500

Item	Color	Power	Lens Diameter	12+	6+	1+
P	Black	20X	18mm	\$17.00	\$18.00	\$20.00
Q	Gold	20X	18mm	\$17.00	\$18.00	\$20.00
R	Chrome	20X	18mm	\$17.00	\$18.00	\$20.00



All items are priced at jeweler's cost, are sold each, unless otherwise noted, and are subject to change without notice. Visit [Stuller.com](http://Stuller.com) for our complete product selections, current pricing, and quantity price breaks. | 337





**B&L® POCKET HASTING TRIPLET LOUPE**

Bausch & Lomb's® finest quality loupe. This is one of the most highly corrected magnifiers available. The triplet lens system corrects spherical and chromatic aberrations. The wide field of view provides sharp focus and eliminates color degradation.

Order # 29-26010

Item	Power	Working Distance	12+	6+	1+
A	10X	1"	\$44.63	\$47.25	\$52.50
B	14X	¾"	\$51.68	\$54.72	\$60.80
C	20X	½"	\$51.68	\$54.72	\$60.80



**VIGOR® ECONOMY LOUPE**

Single lens loupe.

Order # 29-60020

Item	Color	Power	Lens Diameter	12+	6+	1+
D	Black	10X	18mm	\$9.35	\$9.90	\$11.00
E	Gold	10X	18mm	\$11.86	\$12.56	\$13.95
F	Chrome	10X	18mm	\$9.35	\$9.90	\$11.00



**VIGOR® ECONOMY LOUPE**

Triplet loupe with rubber grip is sold with leather carrying case.

Order #	Color	Power	Lens Diameter	12+	6+	1+
29-6000	Gold	10X	18mm	\$13.39	\$14.18	\$15.75



**ECONOMY LOUPE WITH ALUMINUM HOUSING**

Aluminum-body loupe doublet comes with box.

Order #	Color	Power	Lens Diameter	12+	6+	1+
29-7000	Silver	10X	15mm	\$3.27	\$3.47	\$3.85



**DIAMOND-CUT LOUPE**

Diamond-cut impressions are not only attractive but are also functional allowing the user a better grip.

Order # 29-60400

Item	Color	Power	Lens Diameter	12+	6+	1+
G	Black	10X	18mm	\$11.86	\$12.56	\$13.95
	Silver	10X	18mm	\$11.82	\$12.51	\$13.90
	Gold	10X	18mm	\$11.69	\$12.38	\$13.75
H	Black	10X	21.5mm	\$13.56	\$14.36	\$15.95
	Silver	10X	21.5mm	\$13.56	\$14.36	\$15.95
	Gold	10X	21.5mm	\$13.47	\$14.27	\$15.85

**GEMORO® ORIGINAL AND VIP LITE LOUPES**

Superior optical quality, crisp, distortion-free Hasting triplet lens features a durable scratch-resistant coating.

Order # 29-7201

Item	Color	Power	Lens Diameter	Light Type	1+
A	Gold	10X	18mm	LED-UV	\$19.95
	Blue	10X	18mm	LED-UV	\$19.95
	Silver	10X	18mm	LED-UV	\$19.95
	Black	10X	18mm	LED-UV	\$19.95

Order # 29-7202

Item	Color	Power	Lens Diameter	1+
	Blue	10X	20mm	\$31.85
	Black	10X	20mm	\$31.85



**LED ILLUMINATED TRIPLET LOUPE**

The 10X lighted loupe features a 21mm achromatic-aplanatic lens and contains six bright white LED lights that illuminate your field of view. These lighted loupes are great for poor lighting conditions and have an on/off switch so they can be used with or without the light.

- Features diffused LED light source
- Bright white LED light, battery-operated
- Comes in a leather carrying case
- Three Energizer® 395/399 batteries included

Order # 29-67750

Item	Color	Power	Lens Diameter	12+	6+	1+
B	Black	10x	21mm	\$25.46	\$26.96	\$29.95
C	Black	10x	21mm	\$35.28	\$37.35	\$41.50



**LOUPE CHAINS AND CORDS**

Order # 29-60160

Item	Description	Length	12+	6+	1+
D	Gold Tone (metal)	19"	\$6.59	\$6.98	\$7.75
E	Silver Tone (metal)	19"	\$6.97	\$7.38	\$8.20
F	Black Cord	36"	\$5.78	\$6.12	\$6.80



**LED 10X LOUPE WITH SCALE**

10X magnifier with LED lights and mm scale

- Magnification: 10X
- Lens Ø: 30mm
- Number of LEDs: 8
- Smallest graduation: 0.1mm
- Total length measurable: 30mm
- Field of vision: 340mm
- Lens: 3 double lenses

Order #	Description	Power	Lens Diameter	1+
57-7405	Loupe with Scale	10X	30mm	\$57.35



**10X MAGNIFIER WITH SCALE**

Magnifier with mm scale

- Magnification: 10X
- Lens Ø: 19mm
- Smallest graduation: 0.1mm
- Total length measurable: 160mm
- Field of vision: 30mm
- Lens: 3 lenses (fully coated)
- Focus ring: yes
- Weight: 43g
- Dimension: 38x38x40mm

Order #	Power	Lens Diameter	12+	6+	1+
57-7406	10X	19mm	\$38.25	\$40.50	\$45.00





**CARL ZEISS® 10X LOUPE**

High performance, top quality 18mm optical loupe. The shape and function of the lens are a result of the latest research in the field of optics. The aplanatic-achromatic design of the lens is practically free of distortion and chromatic aberrations. Focal distance is one inch. Made in Germany.

Order #	Color	Power	Lens Diameter	12+	6+	1+
29-2606	Black	10X	13mm	\$94.56	\$100.13	\$111.25



**CHELSEA COLOUR FILTER™ EMERALD LOUPE**

Helpful for identifying certain red, blue, and green stones, use this loupe to determine if a stone is natural or synthetic. Can also use to detect synthetic blue spinel and dyes in certain gems. Made in England.

Order #	Description	Color	12+	6+	1+
29-6505	Chelsea Colour Filter™ Emerald Loupe	White	\$30.18	\$31.95	\$35.50



**B&L® SINGLE LENS LOUPE**

Lightweight, black frames with soft, black interior surfaces. Carefully ground lenses are polished from the best optical glass.

Order # 29-13000

Item	Power	Working Distance	12+	6+	1+
A	10X	1"	\$16.15	\$17.10	\$19.00
B	7X	1½"	\$14.03	\$14.85	\$16.50
C	5X	2"	\$14.03	\$14.85	\$16.50
D	4X	2½"	\$14.03	\$14.85	\$16.50

**B&L® TRIPLE APLANATIC LOUPE**

Corrected for spherical and chromatic aberration, little color degradation, and very sharp focus over the entire field of vision, this is one of the best triplet loupes available. Made in Germany.

Item	Order #	Color	Power	Working Distance	12+	6+	1+
E	29-1304	Black	10X	1"	\$58.23	\$61.65	\$68.50



**EUROSCOPE**

This scope was created for the diamond end-user to view the unique hearts and arrows pattern in ideal-cut or other special-cut diamonds.

Item	Order #	Description	1+
F	29-4732	Euroscope	\$59.95

**DIAMOND INSCRIPTION VIEWER**

Our consumer-friendly device holds a ring and easily allows the user to view the mounted diamond's certificate number, which is laser inscribed on its girdle. Features a HOYA 20X Hastings triplet lens, swiveling ring pad, and simple focusing that stays in focus when handed to your customers.

Item	Order #	Description	1+
G	29-4731	Diamond Inscription Viewer	\$48.95

**10X LIGHTED MAGNIFIER WITH MAGLITE®**

Attached directly to the Maglite is a 10X color-corrected compound triplet magnifier made of high-impact nylon composite with rubber eyepiece. The magnifier features a diffuser and one-way reflector so that the viewer's eye is directly above the light, giving the best possible view of diamonds, small gemstones, etc.

Order #	Description	Power	12+	6+	1+
29-6100	Magnifier with Maglite	10X	\$35.96	\$38.07	\$42.30



**DIAMOND VIEW WITH MAGLITE®**

Use this instrument with a Maglite, and it becomes a portable darkfield that allows the user to identify the fillings and flaws in diamonds. Features a high-intensity, miniature darkfield and a distortion-free, 19mm, 10X triplet. Black-oxide finish allows glare-free viewing.

Order #	Description	Power	12+	6+	1+
29-6500	Dark Field Diamond Viewer	10X	\$45.01	\$47.66	\$52.95



**LED FLASH LOUPE**

This loupe is easy to use and features 10X magnification of a 27 millimeter lens. LED light provides a clear view anywhere.

Order #	Description	Power	Lens Diameter	12+	6+	1+
29-2505	LED Flash Loupe	10X	27mm	\$25.46	\$26.96	\$29.95



**IVIEW HANDHELD LED/UV MAGNIFIER**

- Dual 5X and 10X magnification
- Crisp 55mm and 20mm optical quality lens
- Eight white natural daylight LEDs and one UV LED
- Unique ergonomic design with a rubberized paint finish
- Includes three AAA batteries and carrying case
- May also be used for counterfeit bill identification and diamond fluorescence detection

Order #	Description	Power	12+	6+	1+
29-2503	LED/UV Magnifier	5X and 10X	\$16.96	\$17.96	\$19.95



**DAZOR® LED PORTABLE MAGNIFIERS**

Dazor's lightweight hand-held magnifiers are the best choice for magnification on the go. The perfect blend of abundant light and powerful magnification in a handy portable package.

Item	Order #	Description	Power	12+	6+	1+
A	29-2504	12 LED Mini Hand-Held	3.5X	\$44.58	\$47.21	\$52.45
B	29-2504	24 LED Portable Magnifier	3.5X	\$44.58	\$47.21	\$52.45







**UNIVERSAL CLIP-ON LENS FOR SMARTPHONES**

Universal Clip-On Lens can be used on all major smartphones. Can also work on tablets and some laptops. There are three lenses available: macro, wide angle, and fisheye. The macro lens can take clear photos of small objects. The wide angle lens can shoot a larger range for scenery. The 180 degree of the scene can be captured by the fisheye lens. Using these lenses enables you easily enjoy photography and find the instant beauty of the world.

Order #	Description	12+	6+	1+
26-4201	Universal Clip On Lens - Includes 3 Lens Sizes	\$11.90	\$12.60	\$14.00



**5" CLAMP-ON MAGNIFIER FOR BENCH LAMP**

- 2X and 4X – 1" window
- The magnifier is made from optical quality acrylic
- Ideal accessory for use in jewelry making
- Magnifier includes all hardware to install
- Magnifier will flip upwards when not in use

Order #	Description	1+
29-4790	Clamp on Magnifier	\$42.35



**DIAMOND INSPECTION KIT IN GENUINE LEATHER WALLET**

Contains titanium tweezers, 18mm satin loupe with elastic chain, titanium scoop, 4, gem holder, acrylic matching tray, and Selvyt® cloth.

Order #	Description	12+	6+	1+
59-2700	Diamond Inspection Kit	\$17.47	\$18.50	\$20.55



**DRY BROW SWEAT BANDS**

Providing a soft, cool, and sanitized way to dry your brow, these sweatbands absorb perspiration before it trickles down into the eyes or onto spectacles. Fits a wide range of safety hats and headgear, such as OptiVISOR®.

Order #	Description	12+	6+	1+
29-0032	Dry Brow Sweatbands	\$1.87	\$1.98	\$2.20



**OPTIVISOR® BINOCULAR MAGNIFIER**

OptiVISOR lenses are ground and polished to precision ophthalmic standards. The OptiVISOR frame is made of lightweight, durable, impact-resistant materials. The comfortable, continuous headband is fully adjustable to fit any size, quickly and easily. Adjustable pivot knobs hold visor in any position for easy flip-up viewing. Interchangeable lens plates are available for various applications. Not intended for use while soldering.

**A Order # 10-10000** Sold Each

A. OptiVISOR	DA10	DA7	DA5	DA4	DA3	DA2
Focal Distance	4"	6"	8"	10"	14"	20"
Power	3½X	2¾X	2½X	2X	1¾X	1½X
1+	\$43.95	\$43.95	\$40.15	\$40.15	\$40.15	\$40.15



Glass Lens

**B Order # 10-10002** Sold Each

Lens Plates	#10	#7	#5	#4	#3	#2
Focal Distance	4"	6"	8"	10"	14"	20"
Power	3½X	2¾X	2½X	2X	1¾X	1½X
1+	\$29.45	\$28.95	\$28.50	\$28.50	\$28.50	\$28.50

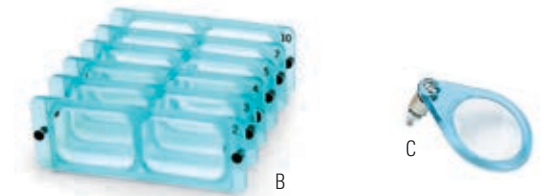

**OPTIVISOR® ACCESSORIES**

Item	Order #	Description	Power	1+
C	29-4700	OptiLoupe Attachment	2½X	\$12.50
	29-4702	Replacement Leather Headband		\$16.70
D	29-4703	Short Light Attachment		\$23.35



**OPTIVISOR® LX**

The OptiVISOR LX lightweight lenses and tough materials are designed to last a lifetime. Its optical prismatic lenses are made from precision ground and highly polished molds. The LX has adjustable side pivots that allow the visor to tilt at your fingertips and a dial adjustment headband that conforms to comfortably fit all head sizes. The LX has a genuine leather padded comfort band with orthopedic felt for extra comfort.

**E Order # 10-10001** Sold Each

OptiVISOR LX	LX 3	LX 7	LX 5	LX 4
Focal Distance	14"	6"	8"	10"
Power	1¾ X	2¾ X	2½ X	2 X
12+	\$23.76	\$24.27	\$24.27	\$23.76
6+	\$25.16	\$25.70	\$25.70	\$25.16
1+	\$27.95	\$28.55	\$28.55	\$27.95



Plastic Lens



**EASY EYES HEAD MAGNIFIER**

This lightweight magnifier has four magnifications in one. Magnification ranges from 1.8X to 4.8X. Has a convenient, flip-down loupe.

Order #	Description	Power	12+	6+	1+
29-4730	Head Magnifier	1.8X - 4.8X	\$8.08	\$8.55	\$9.50



Blue

**OPTISIGHT® VISOR**

Provides hands-free magnification for accurate and efficient viewing. The visor tilts up for normal viewing or down for magnification and can also be worn over prescription glasses. Made with high strength plastic and precision optical grade acrylic prismatic lens, it comes with 3X, 4X, and 5X lenses.

Order # 29-6105 Sold Each

Color	Gray	Blue	Green	Purple	Red	Tan
12+	\$23.76	\$23.76	\$23.76	\$23.76	\$23.76	\$23.76
6+	\$25.16	\$25.16	\$25.16	\$25.16	\$25.16	\$25.16
1+	\$27.95	\$27.95	\$27.95	\$27.95	\$27.95	\$27.95



Gray

Green

Purple

Red

Tan



**B&L® MAGNA VISOR REPLACEMENT LENS**

Replacement 1.8x lens for 29-1313.

Order #	Description	Power	Focal Distance	12+	6+	1+
29-1310	Lens Plate	1.9X	12"	\$10.84	\$11.48	\$12.75
29-1311	Lens Plate	2.5X	8"	\$10.84	\$11.48	\$12.75



A

B

**MEGA-VIEW COMPACT VISORS**

Mega-View MG-2 and MG-3 includes 2X, 2.5X, and 3X lenses. It is easy to use and features a comfortable head mount for stone setting.

Order # 29-47380

Item	Description	12+	6+	1+
A	MG-2 Headband	\$50.58	\$53.55	\$59.50
B	MG-3 Lightweight Frame	\$50.58	\$53.55	\$59.50



Glasses come with carrying case, polishing cloth, screwdriver, and neck strap.



**PRIMO® DIAMOND SETTING GLASSES**

These optic glasses work terrific for diamond setting and repair, watch repair, dental labs, electronics, and hobbyist. All lenses and frames are safety glasses for extra protection. They come in various strengths for use at various working distances. All the optics is ISO and CE certified.

Order # 29-4763

Power	12+	6+	1+
2.5X	\$212.50	\$225.00	\$250.00
3X	\$246.50	\$261.00	\$290.00
3.5X	\$250.75	\$265.50	\$295.00
2X	\$204.00	\$216.00	\$240.00

**REPLACEMENT ATTACHMENTS**

Order #	Description	Power	12+	6+	1+
29-4764	Clip-On Glasses	2.5X	\$212.50	\$225.00	\$250.00
29-4764	Clip-On Glasses	3X	\$246.50	\$261.00	\$290.00



**PRIMO® REPLACEMENT FRAMES FOR 29-4763**

Order # 29-4765 Sold Each

Color	Gray	Black	Red
12+	\$16.96	\$16.96	\$16.96
6+	\$17.96	\$17.96	\$17.96
1+	\$19.95	\$19.95	\$19.95



Red



Gray



Black

All items are priced at jeweler's cost, are sold each, unless otherwise noted, and are subject to change without notice. Visit [Stuller.com](http://Stuller.com) for our complete product selections, current pricing, and quantity price breaks. | 345





**OPTICAID® CLIP-ON MAGNIFIER**

The ultra-light eyeglass loupe is designed for maximum comfort and utility. Lenses are high quality, optical-grade materials made from precision-ground and polished molds. Very superior durability, the lens pivots out of the way for normal viewing and easily aligns when magnification is needed. Changeable cams are included to fit eyeglass frames from 1/4" to 1/4" temple width. The eyeglass clamp easily converts from right to left temple mounting. Made in the USA.

**Order # 29-14000**

Lens	Lens Diameter	Power	12+	6+	1+
Single	15mm	10X	\$20.83	\$22.05	\$24.50
Single	24mm	7X	\$20.83	\$22.05	\$24.50
Single	24mm	5X	\$20.83	\$22.05	\$24.50
Single	24mm	3X	\$20.83	\$22.05	\$24.50

**Order # 29-14050**

Lens	Lens Diameter	Power	12+	6+	1+
Double	24 and 15mm	5X and 10X	\$24.23	\$25.65	\$28.50
Double	24 and 25mm	4X and 7X	\$24.23	\$25.65	\$28.50

**OPTICAID® CLIP-ON MAGNIFIER**

Easily clips onto any eyeglass frame. Provides hands-free magnification of small details without any distortion. Lenses are made of plastic and are optically designed. Sold with carrying case.

**Order # 29-77000**

Lens #	Focal Distance	Power	12+	6+	1+
#3	14"	1 3/4X	\$21.68	\$22.95	\$25.50
#5	8"	2 1/4X	\$21.68	\$22.95	\$25.50
#7	6"	2 3/4X	\$21.68	\$22.95	\$25.50
#10	4"	2 3/4X	\$21.68	\$22.95	\$25.50
#2	20"	1 1/2X	\$21.68	\$22.95	\$25.50



**LED LIGHTING SYSTEM**

This custom-fit lighting attachment for OptiVISOR® type magnifying visor utilizes the latest in LED technology. Reduces shadows and increases visibility in any environment. Lights up holes and deep cavities. Super long battery life. Light remains bright after 16 hours of straight use. Lasts up to 96 hours on a single set of batteries. Bulb life expectancy is more than 100,000 hours. Includes two AA batteries.

Order #	Description	Working Distance	12+	6+	1+
<b>29-4781</b>	LED Lighting System	6" - 14"	\$22.48	\$23.81	\$26.45

**CLIP-ON BINOCULAR MAGNIFIER**

Excellent for small tasks that require hands-free work. Can be used with the comfortable binocular frame or can be clipped onto most eyeglass frames.

- Dual lens system designed to reduce eye strain by convergence on focal point
- Easily flips up for normal viewing and down when magnification is required.

**Order # 29-47250**

Lens #	Focal Distance	Power	12+	6+	1+
#4	10"	2X	\$26.86	\$28.44	\$31.60
#5	8"	2 1/2X	\$26.86	\$28.44	\$31.60
#7	6"	2 3/4X	\$26.86	\$28.44	\$31.60
#3	14"	1 3/4X	\$26.86	\$28.44	\$31.60



**LED MAGNIFIERS**

Clamping glasses magnifier with LED lamp makes both hands free. They can easily be used for reading, drawing, handicraft, tailoring, viewing plants, and more—even under insufficient light. These contain three changeable lens magnifiers (1.5X, 2.5X, 3.5X), and the angle of the lens is adjustable.

**Order # 29-48110**

Item	Description	12+	6+	1+
A	Clamp LED Magnifier and 3 Lenses	\$19.81	\$20.97	\$23.30
B	Frame LED Magnifier and 3 Lenses	\$22.48	\$23.81	\$26.45

**HALF-FRAME TELESIGHT MAGNIFIER**

High-quality prismatic lens in lightweight, half eyeglass frames. Used by those who do not wear glasses. Half-frames stay in place, and lenses lower for magnification and flip up when finished.

**Order # 29-76000**

Lens #	Focal Distance	Power	12+	6+	1+
#43	14"	1 3/4X	\$33.11	\$35.06	\$38.95
#44	11"	2X	\$33.11	\$35.06	\$38.95
#45	9"	2 1/4X	\$33.11	\$35.06	\$38.95
#46	7"	2 1/2X	\$33.11	\$35.06	\$38.95





## Fabricated Metals

- 308 Casting Grain
- 311 Master Alloy
- 313 Sheet
- 316 Round Wire
- 318 Laser Wire/SpeedWire™
- 320 Preform® Sizing Stock
- 321 Sizing Stock
- 326 Tubing
- 329 Pattern Wire
- 330 Solder
- 336 Stampings







## Refined Karats

Refined Karats symbolizes our ongoing environmental consciousness in manufacturing and our promise to act responsibly in all areas of business and production, including water, waste, and energy management. Because of Stuller's compliance with Scientific Certification Systems' (SCS) strict environmental, social, and supply-chain management requirements, our certification allows you to add earth-friendly to the characteristics of the products you offer your customers.

As proof of our commitment to sustainability, Stuller earned recycled content certification in an SCS audit. SCS is a global leader in verification of environmental and sustainability claims with internationally recognized standards, and their certification ensures that all of Stuller's manufactured gold and silver product is certified 100% recycled content.

Stuller's SCS certification is just one part of our company's in-house green initiative, Refined Karats. So whenever you see the Refined Karats logo, you can be assured that product contains 100% recycled precious metal content.



100% RECYCLED GOLD



100% RECYCLED PLATINUM



100% RECYCLED PALLADIUM



100% RECYCLED SILVER

## 100% Recycled

Gold and other precious metals should be mined and refined in a sustainable and responsible manner that respects both the needs of humanity and our environment.

Our position on responsible mining procedures goes much further than the gold mining process itself. It encompasses all aspects of gold: appropriate mining methods on conservation, remediation, and fair labor practices. It also includes proper refining; correct handling of aqua regia acid, scrubbing fumes, and clean emissions.

Only specific, branded gold bars or grain are acceptable in our production operations and up to 100% of raw materials used in production are recycled internally.

We require that our vendors maintain policies and procedures, which mandate social and environmental responsibility for both themselves and their suppliers.

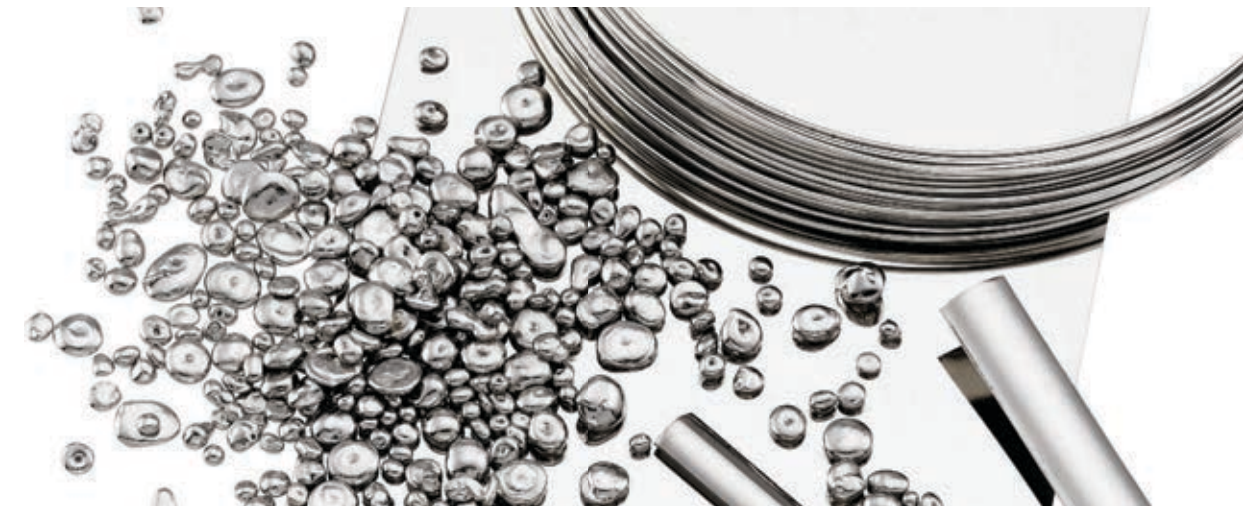

## How do changes affect you?

The latest revision of the European Nickel Directive is meant to address the concerns raised from the 2004 version. More stable artificial sweat solutions are used, which are likely more aggressive. The new requirements are outlined in the table below.

Jewelry Type	Ni release value µg/week/cm <sup>2</sup>	Result
Intimate contact with skin	< 0.11	Compliant
	0.11 – 0.35	Non-conclusive
	> 0.35	Non-compliant
Direct and prolonged contact with skin	< 0.28	Compliant
	0.28 – 0.88	Non-conclusive
	> 0.88	Non-compliant

This new law went into effect on April 2013. The results now include an uncertainty factor where it is considered "non-conclusive." This still puts the burden on the manufacturer to prove it is compliant.

Note: The acceptable nickel release rates are much lower than in earlier standards.

## History of the European Directive

Based on the pioneering work on allergy to nickel in 1991 by Dr. Carola Linden, a Swedish dermatologist, the first European Nickel Directive became a law and came into force in June 1994 in all the European Community Countries. The supporting test method on nickel

release became a Standard (EN 1811), which outlines the requirements of the Directive and pass the nickel release test conducted on jewelry products. The test measures the leaching rate of nickel when the jewelry article is immersed in an artificial sweat solution.

The 1994 European Directive established two basic nickel requirements for jewelry alloys:

- It practically excludes the use of nickel in the alloys that come in intimate contact with parts of human body by restricting the nickel content to be less than 0.05% by weight. Earring posts, ear wire assemblies and other body piercing jewelry articles fall under this restriction.
- For jewelry articles that come into **direct and prolonged** contact with the skin, the test result should show the nickel release rate to be less than 0.5 microgram per square centimeter per week (0.5 µg/week/cm<sup>2</sup>). There is no restriction on the nickel content in the alloy used to make the jewelry articles.

## Previous Revision of European Directive

The practical exclusion of nickel and numerous discrepancies of testing instances brought about the first revision of the Directive in 2004 which dealt now only with nickel release rates and removed the restriction on the nickel content.

In spite of these improvements, the nickel release limits imposed by revisions of the standard have proved to be insufficient to avoid reactions in sensitized subjects. In addition, tests revealed that the artificial sweat degraded over the course of a week's testing which made the nickel release result to be suspect.

STULLER  
METALS CLUB

## Stuller Metals Club

### Volume Pricing on Every Order

The Metals Club enables you to buy only what you need, when you need it, and still receive the price benefits of your average monthly combined purchase totals.

#### MEMBERSHIP BENEFITS INCLUDE—

- Buy direct from the manufacturer.
- Your monthly purchases determine your best price level.
- Order just what you need daily and still receive your Club member volume pricing.
- Enjoy a Club member price level whether you use 40 dwts or 10,000 dwts per month.
- Includes all casting grain, sheet, wire, sizing stock, tubing, and solders.

#### HOW DOES THE METALS CLUB WORK?

You tell us how much gold, platinum, or silver products you purchase per month (including grain, sheet, wire, stock, solder, tubing, etc.). Stuller will use this information to set up your Club Membership Level. You will receive your quantity pricing on every order, even the smaller ones. This allows you to purchase small quantities as needed, yet receive your total quantity price. Also, as long as you meet the quota for one metal quality, you get the quantity pricing for gold, platinum, and silver products. After a period of time (usually 6 months), Stuller will review your metals purchases, advise on how closely you have met your original purchasing estimates, and determine if a change in your Club Level would benefit you.

#### WHAT ARE THE METALS CLUB LEVEL OPTIONS?

- 20 dwt
- 50 dwt
- 100 dwt
- 200 dwt
- 500 dwt
- 1,000 dwt
- 1,500 dwt
- 2,000 dwt

#### WHAT IS THE ACTUAL DISCOUNT OR SAVINGS AT EACH LEVEL?

The pricing for mill products is based on the intrinsic value of the metal (spot markets x karat content) plus a fabrication charge per dwt, based on quantity price break and product type. Regardless of what the gold market is today, tomorrow, or next month, your savings per dwt will always be the same.

#### HOW DO I JOIN?

Call the Stuller Metals Club Member Hotline toll free at 877-619-2173 or email [clubinfo@stuller.com](mailto:clubinfo@stuller.com). One of our friendly Club specialists will walk you through the set-up process and answer any questions concerning the Metals Club price program.

Remember, if you are not a Club member, you may be paying too much.

METAL  
**CLEAN  
SCRAP**

## Metal Clean Scrap Program

Would you like to do your part to lessen your impact on the environment while generating a return for your business? Stuller's Metal Clean Scrap program delivers exactly what you need—

- **Best rates**
- **Quick service**
- **Accurate results**
- **Multiple payment options**

Whether you are clearing out old inventory or cashing in on bench filings and grindings, the result is extra profits.

Metal Quality	OPTION 1 ACCOUNT CREDIT		OPTION 2 50/50		OPTION 3 E-PAYMENT/CHECK		Lab Results In	Payment In			
	Metal Accountability	Processing Fee	Metal Accountability	Processing Fee	Metal Accountability	Processing Fee					
		FA	XRF		FA	XRF					
<b>Gold (Au)</b>	98%	—	—	97%	\$50	\$25	95%	\$50	\$25	3 working days	5 working days
<b>Silver (Ag)</b>	94%	—	—	92%	\$50	\$25	90%	\$50	\$25	3 working days	5 working days
<b>Platinum (Pt)</b>	90%	\$100	N/A	87%	\$100	N/A	85%	\$100	N/A	7 working days	9 working days
<b>Palladium (Pd)</b>	85%	\$100	N/A	82%	\$100	N/A	80%	\$100	N/A	7 working days	9 working days
<b>High-Grade Bench Filings/Grinding</b>											
<b>Gold and Silver</b>	97%	\$100	N/A	95%	\$100	N/A	94%	\$100	N/A	7 working days	9 working days
<b>Platinum and Palladium</b>	80%	\$100	N/A	80%	\$100	N/A	80%	\$100	N/A	7 working days	9 working days

*High-Grade Bench Filings/Grindings have a 10oz. minimum (gross weight). Crucibles, emery paper, buffs or saw blades, computer parts, electronic parts, electrical parts, and plating solutions are not accepted for clean scrap (DO NOT SEND THESE ITEMS). Past due balances will be paid first before any funds are transferred to customer's bank.*



We are committed to being true to you, our customer. To do so, we have always believed that this starts with our practices toward the environment and continues to follow through to our business applications. While others have just begun this journey, ours has been a way of life from the start.

For more information, visit [Stuller.com/CleanScrap](http://Stuller.com/CleanScrap) or call Materials Management at **800-877-7777, Ext. 3616**.





**10K**  
Popular Medium Yellow Color  
Standard Yellow #0143

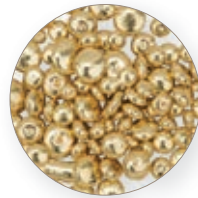

**10K**  
Our Original Bright Yellow  
Bright Yellow #0172

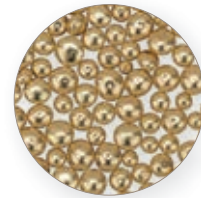

**10K**  
Exceptional Yellow Luster  
Rich Yellow #0145

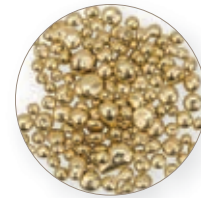

**14K**  
Standard Medium Yellow  
Standard Yellow #0143

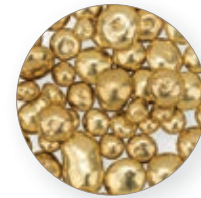

**14K**  
Bright Color Highlights Diamonds  
Bright Yellow #0172



**14K**  
Premium Yellow Luster  
Rich Yellow #0146

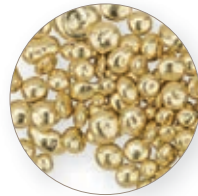

**14K**  
Rich Green Yellow Color  
Euro Yellow #0147



**14K**  
Light/Pale Yellow Color  
Lemon Yellow #0108

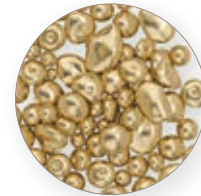

**14K**  
Sheet/wire Fabrication  
Yellow #0300

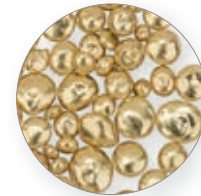

**14K**  
Grain Refined; Deoxidized  
Clean Cast Yellow #0160



**18K**  
Classic 18K Yellow Color  
Rich Yellow #0112

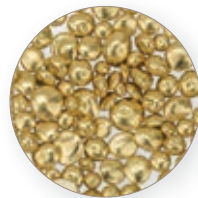

**18K**  
Rich Green Yellow Color  
Euro Yellow #0148

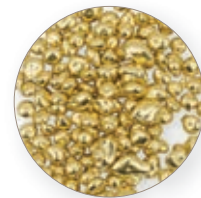

**18K**  
Rich Italian Green Tint;  
Popular in Europe  
Royal Yellow #0115

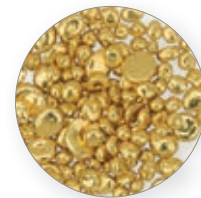

**22K**  
Deep Yellow Color  
Yellow #0116

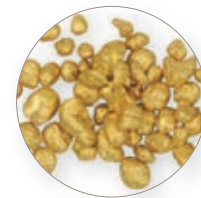

**24K**  
.9995+ Pure Gold  
Yellow #0000

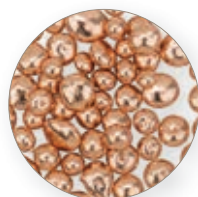

**10K**  
Rose/Pink Gold in Color  
Red #0804

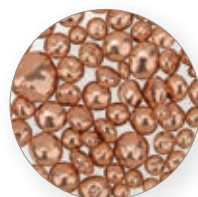

**14K**  
Rose/Pink Gold in Color  
Red #0804

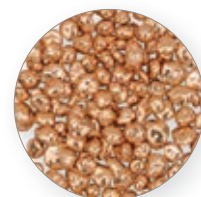

**18K**  
Rose/Pink Gold in Color  
Red #0806

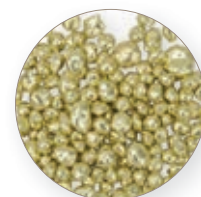

**14K**  
Medium Green Color  
Unique Green #0805

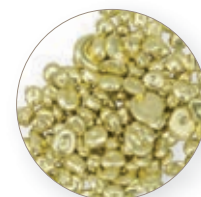

**18K**  
Rich Green Color  
Unique Green #0800



**10K**  
Standard Nickel White  
White #0201

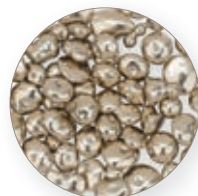

**10K**  
Grade 1 Bright White  
White #0234

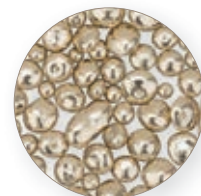

**14K**  
Our Original 14K White  
Standard White #0200



**14K**  
Bright Nickel White Color  
Bright White #0225

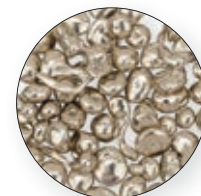

**14K**  
Grain Refined; Deoxidized  
White #0242

## Quality Metals

Using our 40+ years of in-depth metals knowledge, we are constantly working to provide you with more value for your money. As your source for metals, quality starts with us.

Our casting grain is produced using raw metals that are certified to exceed 0.999+ in purity. We analyze every melt by traditional fire assay and X-ray fluorescence techniques to ensure quality and consistency.

Choose from 50 different metal quality and color combinations. All are available with low minimums.

## Certified by SCS

At Stuller, we are your prime source for fabricated metals. You are buying straight from the manufacturer. We make it. We test it. We use it. So, you can buy with confidence, knowing you are getting the best value.

In addition, we are environmentally mindful in all of our manufacturing processes. Our gold, platinum, palladium, and silver metals have been audited and certified by SCS Global Services\* to be 100% recycled content.

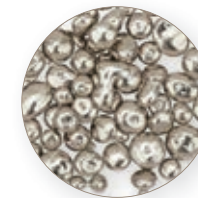

**14K**  
Medium Green Color  
Unique Green #0805



**14K X1®**  
Exceptional Grade 1  
White color, White #0233

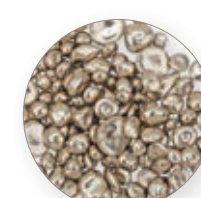

**14K**  
Low Palladium off White Color  
Palladium White #0203



**14K PW**  
High Palladium, Grade 1  
White Color .585  
Palladium White #0228



**18K**  
Low Nickel-Off White Color  
Soft White #0223



**18K**  
Good Nickel White Color  
White #0202



**18K**  
Grade 1 Bright White  
White #0232



**18K**  
Excellent Castability, Good  
Color, Palladium White #0236

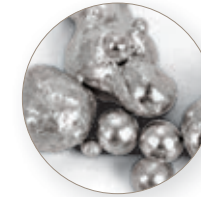

**.950/.05 Platinum/Cobalt**  
Best Color and Castability  
White #0907



**.900/.10 Platinum/Iridium**  
Good Casting Characteristics  
White #0904



**.950/.05 Platinum/Ruthenium**  
0.95 Platinum  
White #0908

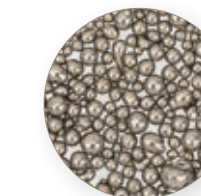

**.950 Super Palladium**  
Enhanced 0.95 Palladium Alloy  
Super White #0937



**Sterling Silver**  
White  
Standard White #0906



**Sterlium Plus®**  
White  
Bright White #0914



**Continuum® Sterling Silver**  
White  
Extreme White #0941



Stuller karat gold casting grains are produced using only high purity raw materials. All metals used in Stuller alloys are certified to exceed 0.999+ in metallic purity. Each melt is analyzed by traditional fire assay and x-ray fluorescence techniques to ensure quality and consistency. Our karat gold casting alloys contain special additives that enhance casting characteristics, provide for less rejects and finishing work, and increase reusability factors. Grain for rolling is formulated specifically for sheet production and wire drawing applications. Our white gold alloys include 10K, 14K, 18K and X1® white gold casting grain, which provide an exceptional white color and finish. Our 14K clean-cast white is enhanced with elements to control grain structure and provide for clean, bright white castings and excellent surface finish. .950 super palladium is a Platinum group metal casting alloy. Stuller offers one of the most comprehensive selections of white precious metals for jewelry.



Quality	Grain Type	Description	Copper	Nominal Composition %				
				Silver	Zinc	Nickel	Palladium	
10K Standard Yellow	Casting	Popular medium yellow color	44.3%	7%	6.9%	—	—	
10K Bright Yellow	Casting	Our original bright yellow	40.5%	11.2%	6.6%	—	—	
10K Rich Yellow	Casting	Exceptional yellow luster	41.9%	9.8%	6.5%	—	—	
10K Yellow	Rolling	Sheet/wire fabrication	39.8%	9.4%	9.4%	—	—	
10K Red	Casting	Rose/pink gold in color	55%	3%	0.5%	—	—	
14K Euro Yellow	Casting	Rich green /yellow .585	22.7%	11.4%	7.6%	—	—	
14K Standard Yellow	Casting	Standard medium yellow	31.6%	5%	1.9%	—	—	
14K Clean Cast Yellow	Casting/Rolling	Grain refined; deoxidized	28.50%	6.70%	6.70%	—	—	
14K Yellow	Casting	Bright color highlights diamonds	29%	8%	4.7%	—	—	
14K Rich Yellow	Casting	Premium yellow luster	28%	9.8%	3.8%	—	—	
14K Lemon Yellow	Casting	Light/pale yellow color	25%	8.6%	8%	—	—	
14K Yellow	Rolling	Sheet/wire fabrication	28.4%	6.7%	6.7%	—	—	
14K Red	Casting	Rose/pink gold in color	39.2%	2%	0.4%	—	—	
14K Green	Casting	Medium green color	2%	39%	0.6%	—	—	
18K Rich Yellow	Casting	Classic 18K yellow color	11.3%	12.5%	0.8%	—	—	
18K Royal Yellow	Casting	Rich italian green tint; popular in Europe	6.7%	16.5%	1.5%	—	—	
18K Yellow	Rolling	Sheet/wire fabrication	9.3%	15%	0.6%	—	—	
18K Euro Yellow	Casting	Rich green yellow color	5.9%	18.2%	0.6%	—	—	
18K Red	Casting/Rolling	Rose/pink gold in color	23.30%	1.20%	0.20%	—	—	
18K Green	Casting	Rich green color	1.2%	23.2%	0.4%	—	—	
22K Yellow	Casting	Deep yellow color	3.5%	4.9%	—	—	—	
24K Yellow	Casting/Rolling	.9995+ pure gold	—	—	—	—	—	
10K White	Casting	Standard nickel white	35.7%	—	12.3%	10.3%	—	
10K White	Rolling	Sheet/wire fabrication	33.8%	—	9%	16%	—	
10K X1® White	Casting	Grade 1 bright white	33.2%	—	9%	16%	—	
14K Soft Nickel White	Casting	Low nickel-off white color	25.5%	—	8.8%	7.5%	—	
14K Standard White	Casting	Our original 14K white	23.80%	—	8.8%	9%	—	
14K Bright White	Casting	Bright nickel white color	21%	—	7.84%	12.73%	—	
14K X1® White	Casting	Exceptional grade 1 white color	17.5%	—	8.95%	15%	—	
14K Clean Cast White	Casting/Rolling	Grain refined; deoxidized	21.5%	—	9%	11%	—	
14K White	Casting/Rolling	Low palladium-off white color	4.6%	26.3%	0.5%	—	10.4%	
14K White	Casting/Rolling	High palladium, grade 1 white color .585	7.2%	20%	0.75%	—	13.5%	
14K White	Rolling	Sheet/wire fabrication	24.2%	—	6.4%	11.1%	—	
18K Soft White	Casting/Rolling	Low nickel-off white color	13.1%	—	5%	6.2%	—	
18K X1® White	Casting	Grade 1 bright white color	8.75%	—	4.1%	12%	—	
18K White	Casting/Rolling	Palladium, excellent cast ability, good color	8.3%	—	—	—	13%	
18K White	Casting/Rolling	Good nickel white color	11.4%	—	2%	11.4%	—	
.900/.10 Platinum/Iridium	Casting/Rolling	Good casting characteristics	—	—	—	—	—	
.950/.05 Platinum/Cobalt	Casting/Rolling	Best color and castability	—	—	—	—	—	
.950/.05 Platinum/Ruthenium	Casting/Rolling	95% platinum	—	—	—	—	—	
.950 Super Palladium	Casting/Rolling	Enhanced 95% palladium alloy	—	—	—	—	95%	

**Minimum order for grain is one pennyweight.**

- To determine the amount of metal needed for casting, multiply the wax weight (including sprue) by the corresponding density (specific gravity). Allow extra for button.
- Optimal flask temperature will vary according to tree size and type of equipment used.

Note: 14K Euro-Yellow, 14K X1, 14K Palladium White, and all 18K casting grains meet the European specifications for all gold fineness.



Quality	Master Alloy Used	Density <sup>1</sup> gm/cm <sup>3</sup>	Vickers Hardness	Melting Temp Range °F	Casting Temp Range °F	Flask <sup>3</sup> Temp °F	1 dwt	50 dwt
10K Standard Yellow	—	11.32	128	1525-1645° F	1770-1855° F	850-950° F	\$35.27	\$33.81
10K Bright Yellow	CA03	11.47	135	1480-1610° F	1735-1820° F	900-1000° F	\$35.27	\$33.81
10K Rich Yellow	—	11.42	131	1490-1615° F	1740-1825° F	850-950° F	\$35.27	\$33.81
10K Yellow	RA03	11.37	131	1505-1605° F	1730-1815° F	850-950° F	\$35.27	\$33.81
10K Red	CA15	11.52	122	1740-1780° F	1905-1990° F	950-1050° F	\$37.21	\$35.74
14K Euro Yellow	—	12.91	134	1520-1615° F	1740-1825° F	900-1000° F	\$47.15	\$45.69
14K Standard Yellow	—	12.84	138	1545-1600° F	1725-1810° F	950-1100° F	\$46.85	\$45.39
14K Clean Cast Yellow	—	12.89	155	1510-1590° F	1715-1800° F	950-1100° F	\$46.85	\$45.39
14K Yellow	CA03	12.99	162	1480-1580° F	1705-1790° F	900-1000° F	\$46.85	\$45.39
14K Rich Yellow	—	13.05	165	1450-1535° F	1660-1745° F	900-1000° F	\$46.85	\$45.39
14K Lemon Yellow	CA04	12.84	138	1545-1600° F	1725-1810° F	850-950° F	\$46.85	\$45.39
14K Yellow	RA03	12.89	136	1675-1720° F	1845-1930° F	950-1050° F	\$46.85	\$45.39
14K Red	CA15	13.03	88	1710-1800° F	1925-2010° F	900-1000° F	\$48.80	\$47.34
14K Green	CA16	13.90	145	1410-1495° F	1620-1705° F	900-1000° F	\$49.12	\$47.66
18K Rich Yellow	CA21	15.39	160	1585-1630° F	1755-1840° F	900-1050° F	\$58.75	\$57.29
18K Royal Yellow	CA23	15.53	126	1615-1655° F	1780-1865° F	900-1050° F	\$58.75	\$57.29
18K Yellow	RA08	15.54	141	1620-1665° F	1790-1875° F	900-1050° F	\$58.75	\$57.29
18K Euro Yellow	—	15.64	115	1645-1720° F	1845-1930° F	900-1050° F	\$58.75	\$57.29
18K Red	—	15.02	257	1670-1685° F	1810-1895° F	950-1050° F	\$60.64	\$59.18
18K Green	CA16	15.89	95	1800-1860° F	1985-2070° F	950-1050° F	\$60.84	\$59.38
22K Yellow	—	17.86	74	1810-1845° F	1970-2055° F	1000-1100° F	\$70.17	\$68.70
24K Yellow	—	19.30	30	1945° F	2070-2155° F	1000-1100° F	\$73.03	\$72.30
10K White	CA06	10.99	165	1715-1750° F	1875-1960° F	1000-1100° F	\$35.18	\$33.71
10K White	RA13	11.17	178	1780-1850° F	1975-2060° F	1000-1100° F	\$35.18	\$33.71
10K X1® White	—	11.17	158	1754-1850° F	2000-2075° F	1000-1100° F	\$35.43	\$33.96
14K Soft Nickel White	CA06	12.53	172	1655-1710° F	1835-1920° F	1000-1100° F	\$46.78	\$45.32
14K Standard White	CA02	12.57	179	1670-1710° F	1835-1920° F	1000-1100° F	\$46.78	\$45.32
14K Bright White	—	12.61	204	1715-1740° F	1865-1950° F	1000-1100° F	\$46.78	\$45.32
14K X1® White	—	12.58	204	1682-1730° F	1880-1955° F	1000-1100° F	\$47.19	\$45.72
14K Clean Cast White	—	12.57	174	1676-1719° F	1875-1990° F	1000-1100° F	\$46.78	\$45.32
14K White	CA17	14.37	125	1865-1920° F	2045-2130° F	1050-1200° F	\$51.12	\$49.66
14K White	—	14.60	150	2030-2165° F	2280-2380° F	1050-1200° F	\$52.22	\$50.76
14K White	RA13	12.71	183	1710-1760° F	1885-1970° F	950-1100° F	\$46.78	\$45.32
18K Soft White	—	14.62	203	1625-1665° F	1790-1875° F	950-1100° F	\$58.60	\$57.14
18K X1® White	—	14.69	231	1662-1925° F	1852-1925° F	950-1100° F	\$58.85	\$57.39
18K White	—	15.66	158	1895-2040° F	2155-2255° F	1000-1150° F	\$64.27	\$62.81
18K White	CA18/RA18	14.86	226	1725-1740° F	1810-1895° F	950-1100° F	\$58.60	\$57.14
.900/.10 Platinum/Iridium	—	21.56	110	3236-3254° F	3360-3400° F	1500-1650° F	\$59.96	\$58.43
.950/.05 Platinum/Cobalt	—	20.10	135	3015-3050° F	3200-3250° F	1400-1550° F	\$60.88	\$59.34
.950/.05 Platinum/Ruthenium	—	20.66	130	3266-3295° F	3360-3400° F	1500-1650° F	\$61.45	\$59.91
.950 Super Palladium	—	12.40	114	2732-2768° F	2875-3000° F	1300-1500° F	\$42.19	\$40.65

STULLER METALS CLUB

Call 877-619-2173 to join the Metals Club and start saving today.

All prices are priced at jeweler's cost based on \$1,400 gold, \$1,150 platinum, \$750 palladium, and \$20 silver and are subject to change without notice. Visit [Stuller.com](http://Stuller.com) for our complete product selections, current pricing, and quantity price breaks. | 357





**Sterling Silver**

Melting Temperature Range: 1590-1660°F  
 Specific Gravity: 10.36  
 Our original standard sterling silver casting grain. Contains 92.7% silver and 7.3% copper.



**Continuum® Sterling Silver**

Melting Temperature Range: 1680-1730°F  
 Specific Gravity: 10.40  
 This platinum group sterling is by far the hardest sterling silver ever developed by Stuller. It has more than 95% precious metal content. Continuum® Sterling has a much higher as-cast hardness that allows setting of high-quality stones in sterling silver jewelry and a much tighter grain size allowing a better more lasting finish, superior oxidizing, and tarnish resistance benefits.



**Sterling 935**

Melting Temperature Range: 1650-1750°F  
 Specific Gravity: 10.23  
 Contains 93.5% silver instead of the traditional 92.5% in most other sterling silver casting grains. The additional silver content provides a white luster similar to pure silver, while maintaining the hardness and durability of standard sterling silver. Used by major manufacturers to enhance their silver product lines.



**Sterling 935 Deox**

Melting Temperature Range: 1435-1610°F  
 Specific Gravity: 10.23  
 Formulated to eliminate firescale and reduce porosity, while maintaining the hardness and durability of standard sterling silver. 93.5% silver content provides a richer silver luster as compared with standard sterling. Several times more tarnish resistant than standard sterling. May be reused with 50% fresh mix. Recommended casting temperature: 1800-1825 deg F.



**Fine Silver**

Melting Temperature Range: 1761-1860°F  
 Specific Gravity: 10.5  
 .9995+ pure silver.



**Sterlium Plus®**

Melting Temperature Range: 1585-1655°F  
 Specific Gravity: 10.25  
 A superior deoxidized sterling silver designed to achieve maximum hardness and eliminate firescale and porosity. Developed to have a hardness approximately equal to standard sterling silver. Ultra white color with an all purpose application. Alloy is extremely user friendly as it is easy to work with for casting as well as fabrication for rolling. \*Stuller now offers all manufactured mill product in Sterlium Plus.\*



**Super Sterling**

Melting Temperature Range: 1555-1645°F  
 Specific Gravity: 10.37  
 Deoxidized sterling silver that is rather resistant to tarnishing. This alloy is softer than standard sterling silver and casts very well. Designed to reduce firescale and porosity. Best used for investment jewelry casting.

Minimum order for silver casting grain is 10 pennyweights.

**CASTING ALLOY**

Used For	Item	Color	Silver Content	Melting Point °F			10 dwt
				10K	14K	18K	
10K/14K Yellow	CA03	Bright Yellow	19.2%	1617° F	1610° F	—	\$6.17
10K/14K Yellow	CA04	Lemon Yellow	20.8%	1530° F	1535° F	—	\$6.32
10K/14K Yellow	CA08	Deep Yellow	12%	1590° F	1580° F	—	\$5.52
10K/14K Yellow	CA09	Yellow	13.2%	1580° F	1575° F	—	\$5.62
10K/14K Yellow	CA10	Reddish Yellow	14.8%	1646° F	1606° F	—	\$5.82
10K/14K Yellow	CA11	Rich Yellow	17.25%	1610° F	1620° F	—	\$6.02
10K/14K Yellow	CA12	Bright Yellow	19.75%	1560° F	1550° F	—	\$6.22
10K/14K Yellow	CA13	Rich Lemon Yellow	27.5%	1620° F	1610° F	—	\$7.02
10K/14K Yellow	CA14	Rich Yellow	33.33%	1580° F	1560° F	—	\$7.62
10K/14K Red	CA15	Red	5%	1780° F	1720° F	—	\$4.82
18K Yellow	CA05	Bright Yellow	60%	—	—	1705° F	\$10.72
18K Yellow	CA20	Reddish Yellow	38.25%	—	—	1660° F	\$8.07
18K Yellow	CA21	Rich Yellow	50.5%	—	—	1630° F	\$9.32
18K Yellow	CA23	Royal Yellow	66.4%	—	—	1755° F	\$10.92
18K/22K Yellow	CA24	Deep Yellow	58%	—	—	1835° F	\$10.07
10K/14K Standard White	CA02	Standard White	—	1840° F	1710° F	—	\$5.20
10K/14K White	CA06	Soft Nickel White	—	1710° F	1734° F	—	\$4.22
14K White	X1	Extreme White	—	—	2250° F	—	\$5.22
14K White	CA17	Palladium White	63%	—	1920° F	—	\$104.36
14K/18K Green	CA16	Green	93.6%	—	1800° F	1860° F	\$13.66
18K White	CA18	Nickel White	—	—	—	1685° F	\$4.22
18K Palladium white	CA19/RA18	Palladium White	2%	—	—	2040° F	\$229.42

Minimum order for master alloy casting grain is 10 pennyweights.

**ROLLING ALLOY**

Used For	Item	Color	Silver Content	Melting Point °F			10 dwt
				10K	14K	18K	
10K/14K Yellow	RA03	Rich Yellow	16%	1605° F	1600° F	—	\$6.01
10K/14K Yellow	RA05	Yellow	9.2%	1600° F	1580° F	—	\$5.23
10K/14K Yellow	RA11	Deep Yellow	11.8%	1550° F	1540° F	—	\$5.46
10K/14K Yellow	RA14	Bright Yellow	20%	1635° F	1625° F	—	\$6.28
10K/14K Yellow	RA16	Rich Yellow	33.33%	1580° F	1560° F	—	\$7.66
10K/14K Red	RA09	Red	5%	1776° F	1707° F	—	\$4.89
18K/22K Yellow	RA06	Deep Yellow	58%	—	—	1835° F	\$10.07
18K Yellow	RA08	Bright Yellow	60%	—	—	1665° F	\$10.56
18K Yellow	RA15	Royal Yellow	66.4%	—	—	1765° F	\$10.92
10K/14K White	RA13	Nickel White	—	1850° F	1760° F	—	\$4.22
10K/14K White	RA02	Soft Nickel White	—	1860° F	1810° F	—	\$4.22
14K White	RA17	Palladium White	63%	—	1920° F	—	\$104.51
14K/18K Green	RA10	Green	93.6%	—	1757° F	—	\$13.66
18K White	RA12	Nickel White	—	—	—	1685° F	\$4.22

Minimum order for master alloy rolling grain is 10 pennyweights.

Stuller master alloys are produced with only the purest metals available. Our master alloys for casting grain are formulated to produce brighter castings, with reduced porosity and uniform grain structure and are non-oxidizing. Master alloys for rolling are specifically formulated for rolling and wire drawing applications. Casting and rolling alloys do not contain gold.



**STULLER METALS CLUB**

Call 877-619-2173 to join the Metals Club and start saving today.



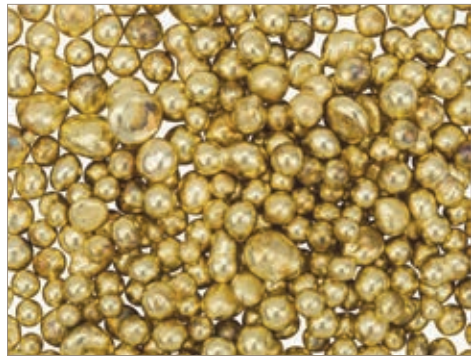

**BASE METALS FOR CASTING**

Order # **GRAIN:113:P**

**ALLOY 99 REPLENISHER**

Designed to deoxidize used gold for casting. 10K Scrap: Add 5 dwt #99 and 3.57 dwt of fine gold for each 100 dwt of 10K scrap being melted. 14K Scrap: Add 4 dwt #99 and 5.60 dwt of fine gold for each 100 dwt of 14K scrap being melted. 18K Scrap: Add 2 dwt #99 and 6.00 dwt of fine gold for each 100 dwt of 18K scrap being melted.

For white gold, the above ratios can be applied, but use will be limited to once or twice due to the yellowing of the white color. Sold in 2 troy ounce bag.

\$12.35



Order # **GRAIN:114:P**

**HERCULOY CASTING CUBES**

An economical bronze alloy containing 5% zinc. The low zinc content releases little fumes or smoke when melted. Color approximates 14K yellow gold. Readily accepts nickel, gold, or rhodium plating, and solders easily with silver solder. Sold by the pound. Melting point 1850°F. Metal to wax ratio 8:1.

\$21.20

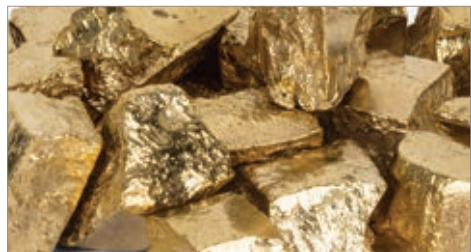

Order # **GRAIN:115:P**

**ART BRASS CASTING CUBES**

An economical brass alloy containing 30% zinc. The low casting temperature and bright yellow color lend itself to jewelry casting. Polishes bright and electroplates/solders beautifully. Overheating can create excessive fumes and smoke. Sold by the pound. Melting point 1700°F. Metal to wax ratio 9:1.

\$21.20



Order # **GRAIN:116:P**

**BRASS CASTING GRAIN**

A high-quality brass casting alloy containing the same deoxidizing agents used in our karat gold casting grain. Castings are bright and firescale free. Color is very close to 14K yellow. Highly recommended for sculpture. Sold by the pound. Melting point 1950°F. Metal to wax ratio 9:1.

\$23.40



Order # **GRAIN:117:P**

**SILICON BRONZE CASTING CUBES**

Our silicon bronze's casting properties are superior to most other bronzes. Cast with few fumes or smoke and can readily be electroplated. Color is darker than our brass and HerculoY formulas. Highly recommended for sculpture. Sold by the pound. Melting point 1850°F. Metal to wax ratio 9:1.

\$21.20



Order # **GRAIN:118:P**

**WHITE BRONZE CASTING GRAIN**

A nickel-free white bronze alloy with a low casting temperature of 1650°F. Accepts rhodium plating after a nickel or gold pre-plate. Can be brazed and polished. Sold by the pound. Melting point 1850°F. Metal to wax ratio 8:1.

\$21.20

Base metals for casting shipping weight is 1 pound.

**SHEET**

Karat Gold, Platinum, and Palladium sheets are supplied flat and 3/4 hard temper unless otherwise requested. Additional options are available in our 14X1® white, which has a premium white color.

Profile	Thickness		Approximate Pennyweights (dwt) Per Square Inch					
	Gauge	mm	Inch	10K	14K	18K	Plat/Ru	.950 pd
—	32 Ga	0.20mm	.008"	0.92	1.08	1.30	1.75	0.97
—	31 Ga	0.23mm	.009"	1.04	1.21	1.40	1.90	1.09
—	30 Ga	0.26mm	.010"	1.15	1.34	1.60	2.18	1.22
—	29 Ga	0.29mm	.011"	1.27	1.48	1.75	2.39	1.37
—	28 Ga	0.32mm	.013"	1.50	1.71	1.95	2.83	1.54
—	27 Ga	0.36mm	.014"	1.62	1.93	2.20	3.05	1.73
—	26 Ga	0.41mm	.016"	6.04	2.16	2.62	3.49	1.94
—	25 Ga	0.46mm	.018"	2.08	2.42	2.85	3.92	2.18
—	24 Ga	0.51mm	.020"	2.31	2.69	3.30	4.36	2.45
—	23 Ga	0.57mm	.023"	2.65	3.09	3.50	5.01	2.75
—	22 Ga	0.64mm	.025"	2.89	3.36	4.16	5.45	3.09
—	21 Ga	0.72mm	.028"	3.23	3.87	4.40	6.10	3.47
—	20 Ga	0.81mm	.032"	3.69	4.30	5.23	6.98	3.90
—	19 Ga	0.91mm	.036"	4.31	4.88	5.70	7.85	4.38
—	18 Ga	1.02mm	.040"	4.83	5.48	6.62	8.93	5.27
—	17 Ga	1.15mm	.045"	5.19	6.04	7.10	9.81	5.53
—	16 Ga	1.29mm	.051"	6.10	6.90	8.36	11.12	6.20
—	15 Ga	1.45mm	.057"	6.58	7.66	9.00	12.43	6.97
—	14 Ga	1.63mm	.064"	7.39	8.60	10.50	13.96	7.82
—	13 Ga	1.83mm	.072"	8.31	9.67	11.40	15.70	8.79
—	12 Ga	2.05mm	.081"	9.35	10.88	13.30	17.66	9.86
—	11 Ga	2.31mm	.091"	10.50	12.22	14.25	19.84	11.07
—	10 Ga	2.59mm	.102"	11.77	13.70	16.70	22.24	12.43
—	9 Ga	2.91mm	.114"	13.16	15.31	18.05	24.86	13.96
—	8 Ga	3.26mm	.128"	14.78	17.19	19.80	27.91	15.68

SHEET (Based on 20 Gauge)	Approximate Pricing Per Pennyweight (dwt)		
	1 dwt	50 dwt	100 dwt
<b>10K Yellow or White</b>	\$35.64	\$33.78	\$33.47
<b>14K Yellow or White</b>	\$47.22	\$45.35	\$45.04
<b>18K Yellow or White</b>	\$59.12	\$57.25	\$56.94
<b>.950/.05 Platinum/Ruthenium</b>	\$63.09	\$62.04	\$61.92
<b>Palladium</b>	\$43.88	\$42.83	\$42.71



- Minimum order is one square inch per size.
- Maximum sheet size is 4x14 for same or next day shipping.

Longer lengths are available with additional lead time. Annealing available upon request.

LEAD TIMES: 10K yellow, 14K yellow, 14K white, 18K yellow and sterling silver will ship same day in most cases. Back orders will ship the following day. All other metal qualities are MTO (made to order) and will ship within three working days in most cases. Same-day shipping subject to order specifications, special request, and inventory on hand at time of order. Additional charges and lead times may apply to odd quantities.

**STULLER METALS CLUB**

Call **877-619-2173** to join the Metals Club and start saving today.





3" Wide minimum order for sheet is 3"x1", maximum is 3"x36".

**3" Wide**

**Continuum® Sterling Silver** - Continuum sterling silver sheet is supplied in standard temper (medium-hard) mill finish. Available in even gauges 12 through 14.

**Sterling Silver** - Sterling silver sheet is supplied in annealed/dead soft temper. Available in even gauges 14 through 24.

Profile	Thickness			Approximate Pennyweights (dwt) Per Size							
	Gauge	mm	Inch	3" x 1"		3" x 3"		3" x 6"		3" x 12"	
—	24	.51	.020"	6.62	6.58	19.86	19.73	39.73	39.46	79.45	78.92
—	22	.64	.025"	8.33	8.28	25.00	24.83	50.00	49.66	100.00	99.32
—	20	.81	.032"	10.54	10.54	10.47	31.62	63.24	62.81	126.48	125.63
—	18	1.02	.040"	13.28	13.14	39.84	39.42	79.67	78.83	159.35	157.67
—	16	1.29	.051"	16.74	16.63	50.23	49.89	100.45	99.77	200.90	199.55
—	14	1.63	.064"	21.11	20.97	63.34	62.91	126.67	125.82	253.34	251.64
—	12	2.05	.081"	26.61	—	99.83	—	159.66	—	319.32	—

**6" Wide**

**Sterlium Plus®** - Sterlium plus sheet is supplied in annealed/dead soft temper as well as our standard temper (medium-hard) mill finish. Available in even gauges 8 through 30.

**Fine Silver** - .9995 Fine silver sheet is supplied in annealed/dead soft temper.

Available in even gauges 14 through 30.

Profile	Thickness			Approximate Pennyweights (dwt) Per Size							
	Gauge	mm	Inch	6" x 1"		6" x 3"		6" x 6"		6" x 12"	
—	30	0.26mm	.010"	6.52	6.63	19.56	19.89	39.12	39.78	78.24	79.56
—	28	0.32mm	.013"	8.22	8.36	24.66	25.08	49.32	50.16	98.64	100.32
—	26	0.41mm	.016"	10.37	10.54	31.11	31.62	62.22	63.24	124.44	126.46
—	24	0.51mm	.020"	13.12	13.33	39.36	39.99	78.72	79.98	157.44	156.96
—	22	0.64mm	.025"	16.51	16.78	49.53	50.34	199.06	100.68	198.12	201.36
—	20	0.81mm	.032"	20.88	21.22	62.64	63.66	125.28	127.32	250.56	254.64
—	18	1.02mm	.040"	26.30	26.74	78.90	80.22	157.80	160.44	315.60	320.88
—	16	1.29mm	.051"	33.16	33.71	99.48	101.13	198.96	202.26	397.92	404.52
—	14	1.63mm	.064"	41.82	42.51	125.46	127.53	250.92	255.06	501.84	510.12
—	12	2.05mm	.081"	52.71	—	158.13	—	316.26	—	632.52	—
—	10	2.59mm	.102"	66.48	—	199.44	—	398.88	—	797.76	—
—	8	3.26mm	.128"	83.84	—	251.52	—	503.04	—	1006.08	—

6" Wide minimum order for sheet is 6"x1", maximum is 6"x36".

**12" Wide**

**Sterling Silver** - Sterling silver sheet is supplied in annealed/dead soft temper with a brushed finish.

Available in even gauges 16 through 24.

Profile	Thickness			dwt/inch	Approximate Pennyweights (dwt) Per Size			
	Gauge	mm	Inch		12" x 1"	12" x 6"	12" x 12"	12" x 18"
—	24	0.51mm	.020"	2.19	26.31	157.83	315.66	473.49
—	22	0.64mm	.025"	2.76	33.11	198.65	397.31	595.96
—	20	0.81mm	.032"	3.49	41.88	251.27	502.54	753.80
—	18	1.02mm	.040"	4.36	52.32	313.92	627.84	941.76
—	16	1.29mm	.051"	5.54	66.48	398.89	797.77	1196.66

12" Wide minimum order for sheet is 12"x1", maximum is 12"x36".

Silver Sheet	Approximate Pricing Per Pennyweight (dwt)/Ounce (oz)					
	1 dwt	1 oz	400 dwt	20 oz	1000 dwt	50 oz
Fine Silver	\$1.36	\$27.20	\$1.30	\$26.00	\$1.28	\$25.60
Sterling Silver	\$1.51	\$30.20	\$1.45	\$29.00	\$1.43	\$28.60
Sterlium Plus	\$1.51	\$30.20	\$1.45	\$24.00	\$1.43	\$28.60
Continuum Sterling Silver	\$2.71	\$54.20	\$2.67	\$53.40	\$2.65	\$53.00



100% Recycled Gold and Silver. Visit [Stuller.com/SensibleSourcing](http://Stuller.com/SensibleSourcing) for more information.

**YELLOW GOLD-FILLED**

**10K 1/10 Single-Sided Sheet.** 10% 10K yellow gold-filled by weight (10/10) mechanically bonded to bronze base metal. Stocked in soft 4" x 30" sheets. One dimension must be 4" when ordering.

Minimum order for sheet is 4x1 inches.

Profile	Thickness			Approximate Pennyweights (dwt) Per Size			
	Gauge	mm	Inch	4" x 1"	4" x 3"	4" x 6"	4" x 12"
—	16	1.29mm	.050"	18.80	56.40	112.80	225.60
—	14	1.63mm	.060"	22.60	67.80	135.60	271.20

**10K 1/10 Single-Sided Sheet.**

**14K 1/20 Single-Sided Sheet.** 5% 14K yellow gold-filled by weight (14/20). Sheet is clad on one side. Great for stampings and jewelry requiring a single-sided, gold-filled surface. Stocked in soft 3" x 30" sheets. One dimension must be 3" when ordering.

Minimum order for sheet is 3x1 inches.

Profile	Thickness			Approximate Pennyweights (dwt) Per Size			
	Gauge	mm	Inch	3" x 1"	3" x 3"	3" x 6"	3" x 12"
—	22	0.64mm	.025"	7.20	21.60	43.20	86.40
—	20	0.81mm	.032"	14.10	42.30	84.60	169.60

**14K 1/20 Single-Sided Sheet.**

Profile	Thickness			Approximate Pennyweights (dwt) Per Size			
	Gauge	mm	Inch	3" x 1"	3" x 3"	3" x 6"	3" x 12"
—	26	0.41mm	.016"	9.21	27.60	55.20	110.50

**14K 1/40 x 1/40 Double-Sided Sheet.**

Yellow Gold-Filled Sheet	Approximate Pricing Per Pennyweight (dwt)/Ounce (oz)					
	1 dwt	1 oz	50 dwt	25 oz	100 dwt	50 oz
1/10 10K Yellow Gold Filled	\$3.83	\$76.60	\$3.36	\$67.20	\$3.22	\$64.40
1/20 14K Yellow Gold Filled	\$3.83	\$76.60	\$3.36	\$67.20	\$3.22	\$64.40
1/40 14K Yellow Gold Filled	\$3.83	\$76.60	\$3.36	\$67.20	\$3.22	\$64.40



**14K 1/40 x 1/40 Double-Sided Sheet.** 5% 14K yellow gold-filled by weight (14/40 x 14/40). Excellent for earrings and other applications requiring double-sided, gold-filled surfaces. Stocked in soft 3" x 30" sheets. One dimension must be 3" when ordering.

Minimum order for sheet is 3x1 inches.

**GOLD STRIP**

Karat gold strip is supplied flat with a 3/4 hard-temper unless otherwise requested. Minimum order varies according to width of strip. Approximate pennyweights per inch (14K) and corresponding minimum order length are listed below.

Width	Minimum Order Length	14K/Thickness (inches)						
		15 Gauge 0.057"	17 Gauge 0.045"	20 Gauge 0.032"	24 Gauge 0.020"	26 Gauge 0.016"	28 Gauge 0.013"	30 Gauge 0.010"
24mm	1.5"	7.34	5.79	4.12	2.58	2.06	1.67	1.29
22mm	1.5"	6.73	5.31	3.78	2.36	1.89	1.53	1.18
20mm	1.5"	6.12	4.83	3.43	2.15	1.72	1.40	1.07
18mm	1.5"	5.50	4.35	3.09	1.93	1.55	1.26	.97
16mm	1.5"	4.89	3.86	2.75	1.72	1.37	1.12	.86
15mm	2"	4.59	3.62	2.56	1.61	1.29	1.05	.81
14mm	2"	4.28	3.38	2.40	1.50	1.20	.98	.75
13mm	2.5"	3.98	3.14	2.23	1.40	1.12	.91	.70
12mm	3"	3.67	2.90	2.06	1.29	1.03	.84	.64
11mm	3"	3.36	2.66	1.89	1.18	.94	.77	.59
10mm	3"	3.06	2.41	1.72	1.07	.86	.70	.54
9mm	3"	2.75	2.17	1.55	.97	.77	.63	.48
8mm	3.5"	2.45	1.93	1.37	.86	.69	.56	.43
7mm	4"	2.14	1.69	1.20	.75	.60	.49	.38



Annealing is available upon request. For strip less than 7mm wide, see flat bezel. Available qualities include 10K, 14K, 18K, and 14K, and 18K palladium white.

Gold Strip (based on 20 gauge)	Approximate Pricing Per Pennyweight (dwt)		
	1 dwt	50 dwt	100 dwt
10K Yellow or White	\$59.12	\$57.25	\$56.94
14K Yellow or White	\$35.64	\$33.78	\$33.47
18K Yellow or White	\$47.22	\$45.35	\$45.04

All prices are priced at jeweler's cost based on \$1,400 gold, \$1,150 platinum, \$750 palladium, and \$20 silver and are subject to change without notice. Visit [Stuller.com](http://Stuller.com) for our complete product selections, current pricing, and quantity price breaks. | 363



**GOLD ROUND WIRE**

Round wire is supplied in continuous coils with a medium-hard temper unless otherwise requested. Straight wire is also available in 10 through 24 gauge in lengths up to 24 inches. Annealing is available upon request. Please visit [Stuller.com](http://Stuller.com) for all available qualities and sizes.

Profile	Gauge	Thickness		Approximate Pennyweights (dwt) Per Square Inch				
		mm	Inch	10K	14K	18K	Plat/Ru	Pall
•	30	0.26mm	.010"	0.01	0.01	0.01	0.02	0.01
•	29	0.29mm	.011"	0.01	0.01	0.02	0.02	0.01
•	28	0.32mm	.013"	0.02	0.02	0.02	0.03	0.02
•	27	0.36mm	.014"	0.02	0.02	0.03	0.03	0.02
•	26	0.41mm	.016"	0.03	0.03	0.03	0.04	0.03
•	25	0.46mm	.018"	0.03	0.04	0.04	0.06	0.03
•	24	0.51mm	.020"	0.04	0.04	0.05	0.07	0.04
•	23	0.57mm	.023"	0.05	0.05	0.07	0.09	0.06
•	22	0.64mm	.025"	0.06	0.07	0.08	0.11	0.06
•	21	0.72mm	.028"	0.07	0.08	0.10	0.13	0.08
•	20	0.81mm	.032"	0.10	0.11	0.13	0.18	0.10
•	19	0.91mm	.036"	0.13	0.14	0.17	0.22	0.12
•	18	1.02mm	.040"	0.16	0.17	0.21	0.29	0.16
•	17	1.15mm	.045"	0.19	0.23	0.26	0.35	0.20
•	16	1.29mm	.051"	0.27	0.28	0.33	0.45	0.25
•	15	1.45mm	.057"	0.32	0.35	0.41	0.56	0.31
•	14	1.63mm	.064"	0.38	0.44	0.53	0.70	0.39
•	13	1.83mm	.072"	0.53	0.55	0.67	0.89	0.50
•	12	2.05mm	.081"	0.61	0.73	0.84	1.12	0.63
•	11	2.31mm	.091"	0.78	0.91	1.05	1.42	0.79
•	10	2.59mm	.102"	0.98	1.11	1.33	1.78	0.99
•	9	2.91mm	.114"	1.34	1.52	1.73	2.23	1.25
•	8	3.26mm	.128"	1.62	1.76	2.13	2.81	1.58
•	7	3.67mm	.144"	2.00	2.32	2.65	3.55	2.00
•	6	4.12mm	.162"	2.48	2.80	3.49	4.50	2.52

Round Wire (Based on 20 Gauge)	Approximate Pricing Per Pennyweight (dwt)		
	1 dwt	50 dwt	100 dwt
10K Yellow or White	\$35.52	\$33.69	\$33.39
14K Yellow or White	\$47.10	\$45.27	\$44.96
18K Yellow or White	\$59.00	\$57.17	\$56.86
.950/.05 Platinum/Ruthenium	\$63.09	\$62.04	\$61.92
Palladium	\$43.88	\$42.83	\$42.71

Minimum orders—  
 6-12 gauges – 1 inch per size and quality.  
 14-24 gauges – 3 inches per size and quality.  
 25-30 gauges – 36 inches per size and quality.

LEAD TIMES: 10K yellow, 14K yellow, 14K white, 18K yellow, and sterling silver will ship same day in most cases. Back orders will ship the following day. All other metal qualities are MTO (made to order) and will ship within three working days in most cases. Same-day shipping subject to order specifications, special request, and inventory on hand at time of order. Additional charges and lead times may apply to odd quantities.

**SILVER ROUND WIRE**

Round Wire is supplied coiled in annealed/dead soft temper or standard (1/2 hard) temper. Available in sterling silver, Sterlium Plus®, Continuum® sterling silver, and fine silver. **Small Diameter Wire** is sold in 100 pennyweight increments on plastic spools supplied in 1/2 hard temper. Available in 26, 28, and 30 gauge. **.9995 Fine Silver Wire** is supplied in annealed/dead soft temper.

Profile	Gauge	Thickness		Minimum Order	Approximate dwt/ft. Sterlium/Fine	20 dwt (1 oz.) Length (in.)			100 dwt (5 oz.) Length (ft.)		
		mm	Inch			Sterlium	Fine	Continuum	Sterlium	Fine	Continuum
•	30	.26mm	.010"	72"	0.10	2342"	—	2953"	975.7	959.9	1230.4
•	28	.32mm	.013"	72"	0.15	1475"	—	1861"	614.8	604.8	775.2
•	26	.41mm	.016"	72"	0.23	927"	—	—	386.1	379.8	—
•	24	.51mm	.020"	36"	0.40	579"	570"	731"	241.5	237.5	304.5
•	22	.64mm	.025"	36"	0.65	366"	360"	461"	152.4	150.0	192.2
•	21	.72mm	.028"	24"	0.80	288"	—	—	120.1	120.1	—
•	20	.81mm	.032"	24"	1.00	229"	225"	288"	95.3	93.7	120.2
•	18	1.02mm	.040"	24"	1.74	144"	142"	182"	60.0	59.1	75.5
•	16	1.29mm	.051"	24"	2.71	91"	89"	114"	37.8	37.2	47.6
•	14	1.63mm	.064"	12"	4.08	57"	56"	72"	23.8	23.4	30.0
•	12	2.05mm	.080"	12"	6.72	36"	—	—	15.0	14.7	—
•	10	2.59mm	.102"	12"	11.16	23"	—	—	9.4	9.2	—
•	9	2.91mm	.114"	12"	13.44	18"	—	18"	7.5	7.5	7.5
•	8	3.26mm	.128"	12"	16.80	14"	—	—	5.9	5.8	—
•	6	4.12mm	.162"	12"	28.32	9"	—	—	3.7	3.7	—
•	4	5.19mm	.204"	12"	43.50	6"	—	—	2.3	2.3	—

Silver Coiled Wire	Approximate Pricing Per Pennyweight (dwt)/Ounce (oz)					
	1 dwt	1 oz	400 dwt	20 oz	1000 dwt	50 oz
Continuum® Sterling Silver	\$2.73	\$56.80	\$2.66	\$55.40	\$2.64	\$55.00
Fine Silver	\$1.38	\$25.40	\$1.31	\$24.20	\$1.29	\$23.80
Sterlium Plus®	\$1.43	\$26.40	\$1.36	\$25.20	\$1.34	\$24.80

**YELLOW GOLD-FILLED ROUND WIRE**

1/20-14K yellow gold-filled round wire is 5% 14K yellow gold by weight and supplied coiled. Available in 8 through 26 gauge in 1/2 hard or soft temper as listed below.

Profile	Gauge	Thickness		Minimum Order	Approximate dwt/ft.	20 dwt (1 oz.) 100 dwt (5 oz.)		Available Temper
		mm	Inch			Length (in.)	Length (ft.)	
•	26	0.41mm	.016"	60"	0.24	1000"	416.7	Soft
•	24	0.51mm	.020"	60"	0.36	667"	277.8	1/2 Hard, Soft
•	22	0.64mm	.025"	60"	0.60	400"	166.7	1/2 Hard
•	21	0.72mm	.028"	48"	0.71	339"	141.3	1/2 Hard
•	20	0.81mm	.032"	36"	0.96	250"	104.1	1/2 Hard, Soft
•	18	1.02mm	.040"	24"	1.45	167"	69.5	1/2 Hard, Soft
•	16	1.29mm	.051"	24"	2.28	105"	43.9	1/2 Hard, Soft
•	14	1.63mm	.064"	12"	3.84	63"	26.0	Soft
•	12	2.05mm	.080"	12"	4.80	50"	17.9	Soft
•	10	2.59mm	.102"	6"	9.36	26"	10.7	Soft
•	8	3.26mm	.128"	6"	15.00	16"	6.7	Soft

YGF Round Wire	Approximate Pricing Per Pennyweight (dwt)/Ounce (oz)					
	1 dwt	1 oz	50 dwt	25 oz	100 dwt	50 oz
1/20 14K Yellow Gold Filled	\$3.83	\$73.00	\$3.36	\$63.80	\$3.22	\$60.80



100% Recycled Gold and Silver.  
 Visit [Stuller.com/SensibleSourcing](http://Stuller.com/SensibleSourcing) for more information.

STULLER  
 METALS CLUB

Call 877-619-2173 to join the Metals Club and start saving today.



**LASER WIRE SPOOLS**

All laser wires are annealed dead soft to provide the best weld possible. They come packaged in reusable plastic spools and available in lengths, ranging from 3 feet to 20 feet. Prices based on 20-foot spools unless otherwise noted. (\*) Denotes those provided in 30 gauge spools.



Metal Quality	Spool Gauge	Individual Spools (dwt) Per Spool	3 ft. Spool Price
.585 Platinum (PT58)	30	0.52	\$35.64
.585 Platinum (PT58)	36	0.14	\$11.62
.900/.10 Platinum/Iridium	28	1.02	\$68.31
.900/.10 Platinum/Iridium	30	0.64	\$45.07
.950/05 Platinum/Ruthenium	28	0.98	\$67.20
.950/.05 Platinum/Cobalt	28	0.98	\$66.90
.950/.05 Platinum/Cobalt	36	1.03	\$70.67

**LASER WIRE KITS**

Laser wire kits are supplied in a handy plastic compartment box and feature an assortment of different qualities of metal individually spooled for ease of use with laser welders. All laser wires are annealed dead soft.



**WIRE:294198:P**

28 Gauge Kit, \$450.00 each

Includes: 3ft spools (1 of each): 10k yellow, 14k yellow (zinc-free), 14k palladium-white, 18k yellow, 18k white, 18k palladium-white, platinum/iridium, platinum/cobalt, stainless steel, titanium, silver eyeglass frame wire, silver weld-hard and 15-2061 (plastic compartment box).

**WIRE:294199:P**

30 Gauge Kit, \$270.00 each

Includes: 3ft spools (1 of each): 10k yellow, 14k yellow (zinc-free), 14k palladium-white, 18k yellow, 18k white, 18k palladium-white, platinum/iridium, stainless steel, titanium, silver eyeglass frame wire, silver weld-hard, silver braze-easy and 15-2061 (plastic compartment box).

Metal Quality	Spool Gauge	Individual Spools			20 ft. Spool Price
		Pennyweights (dwt) 5 ft.	10 ft.	20 ft.	
10K Yellow	28	0.90	1.80	3.60	\$139.87
10K Yellow	30	0.59	1.19	2.27	\$89.30
10K Yellow	36	0.14	0.28	0.58	\$25.19
14K Yellow	28	1.01	2.03	4.00	\$201.39
10K White	28	-	1.76	-	\$70.73
10K White	36	-	-	0.55	\$24.30
14K Yellow	30	0.62	1.28	2.56	\$130.01
14K Yellow	32	-	-	1.64	\$85.08
14K Yellow	36	0.17	0.32	0.65	\$35.56
14K Yellow (Zinc-Free)	28	-	-	4.39	\$222.01
14K Yellow (Zinc-Free)	30	-	-	2.77	\$141.02
14K Yellow (Zinc-Free)	36	-	-	0.69	\$37.85
14K White	28	-	-	4.01	\$201.52
14K White	30	0.63	1.26	2.52	\$127.93
14K White	32	-	-	1.64	\$85.01
14K White	36	-	0.32	0.63	\$18.78
14K X1® White	30	0.62	1.29	2.54	\$129.20
14K X1® White	33	-	-	1.26	\$65.48
14K Palladium White	28	1.13	2.27	4.54	\$41.60
14K Palladium White	30	0.75	1.50	-	\$83.80
14K Palladium White	32	-	-	1.83	\$102.31
14K Palladium White	36	0.15	0.36	0.71	\$41.60
14K Rose	30	0.65	1.25	2.50	\$126.87
14K Rose	36	-	0.32	-	\$19.05
18K Yellow	28	1.22	2.45	4.90	\$304.08
18K Yellow	30	0.81	1.62	3.24	\$52.81
18K Yellow	32	-	-	1.97	\$99.23
18K Yellow	33	-	-	1.55	\$99.23
18K Yellow	36	0.17	0.35	0.81	\$53.03
18K Yellow (Zinc-Free)	28	-	-	4.94	\$61.98
18K Yellow (Zinc-Free)	30	-	-	3.24	\$203.83
18K Yellow (Zinc-Free)	36	-	-	0.81	\$53.42
18K White	28	1.16	2.31	4.63	\$287.15
18K White	30	0.73	1.52	2.90	\$180.90
18K White	32	-	-	1.87	\$118.78
18K White	36	0.16	0.40	0.76	\$50.00
18K Palladium White	28	1.28	2.56	5.15	\$348.14
18K Palladium White	30	0.85	1.61	3.38	\$59.70
18K Palladium White	33	-	-	1.62	\$112.60
18K Palladium White	36	0.18	0.36	0.75	\$53.64
18K Green	36	-	-	0.78	\$51.58
19k White	30	0.76	1.52	3.05	\$205.10
19k White	36	0.19	0.38	0.76	\$53.48
22k Yellow	30	-	1.86	-	\$138.62
Palladium	30	-	-	2.41	\$114.77
Palladium	36	-	-	0.58	\$30.00
Silver Eye-Glass Frame Wire	30	-	-	2.07	\$6.62
Silver Eye-Glass Frame Wire	35	-	-	0.71	\$4.24
Silver Weld-Hard	30	-	-	1.95	\$6.41
Silver Braze-Easy	30	-	-	1.90	\$6.32
Silver Weld/Braze-Medium	30	-	-	1.99	\$6.47
Super Sterling Silver	28	-	-	3.31	\$8.78
Super Sterling Silver	30	-	-	2.04	\$6.56
Super Sterling Silver	36	-	-	0.51	\$3.89
Continuum Sterling Silver	30	-	-	2.06	\$9.90
Continuum Sterling Silver	36	-	-	0.53	\$4.77
Sterlium Plus	30	-	-	2.07	\$6.62
Silver/Palladium (Stulladium)	30	-	-	2.16	\$46.62
Stainless Steel	28	-	-	2.11	\$7.95
Stainless Steel	30	-	-	1.70	\$7.95
Stainless Steel	36	-	-	0.38	\$7.95
Titanium	30	-	-	0.90	\$9.95
.900/.10 Platinum/Iridium	33	-	-	2.16	\$142.20
.900/.10 Platinum/Iridium	36	-	0.54	-	\$37.53
.950/.05 Platinum/Ruthenium	35	-	-	1.29	\$87.53

**SPEEDWIRE™ LASER WIRE**



Order #	Description	Jeweler's Cost
SPEEDWIRE:146:P	10K Yellow 30 Gauge (.25mm) 10ft. Spool	\$49.54
SPEEDWIRE:138:P	14K White 28 Gauge (.32mm) 10ft. Spool	\$106.14
SPEEDWIRE:140:P	14K White 30 Gauge (.26mm) 10ft Spool	\$69.10
SPEEDWIRE:141:P	14K White 32 Gauge (.20mm) 10ft Spool	\$46.40
SPEEDWIRE:106:P	14K X1® White 30 Gauge (.26mm) 10ft. Spool	\$68.87
SPEEDWIRE:143:P	14K Palladium White 28 Gauge (.32mm) 10ft Spool	\$129.31
SPEEDWIRE:108:P	14K Palladium White 30 Gauge (.26mm) 10ft. Spool	\$83.64
SPEEDWIRE:144:P	14K Palladium White 36 Gauge (.13mm) 10ft Spool	\$23.85
SPEEDWIRE:133:P	14K Yellow 28 Gauge (.32mm) 10ft. Spool	\$107.78
SPEEDWIRE:105:P	14K Yellow 30 Gauge (.26mm) 10ft. Spool	\$70.32
SPEEDWIRE:107:P	14K Yellow (Zinc-free) 30 Gauge (.26mm) 10ft. Spool	\$75.70
SPEEDWIRE:145:P	14K Yellow (Zinc-free) 36 Gauge (.13mm) 10ft Spool	\$23.43
SPEEDWIRE:139:P	14K Rose 30 Gauge (.26mm) 10ft Spool	\$70.92
SPEEDWIRE:110:P	18K White 30 Gauge (.26mm) 10ft. Spool	\$95.80
SPEEDWIRE:126:P	18K Palladium White 28 Gauge (.32mm) 10ft. Spool	\$178.58
SPEEDWIRE:112:P	18K Palladium White 30 Gauge (.26mm) 10ft. Spool	\$119.97
SPEEDWIRE:117:P	18K Palladium White 33 Gauge (.18mm) 10ft. Spool	\$60.61
SPEEDWIRE:130:P	18K Palladium White 33 Gauge (.18mm) 15ft. Spool	\$87.43
SPEEDWIRE:121:P	18K Palladium White 36 Gauge (.13mm) 10ft. Spool	\$33.21
SPEEDWIRE:127:P	18K Palladium White 36 Gauge (.13mm) 20ft. Spool	\$60.45
SPEEDWIRE:109:P	18K Yellow 30 Gauge (.26mm) 10ft. Spool	\$101.52
SPEEDWIRE:142:P	18K Yellow 32 Gauge (.26mm) 10ft Spool	\$67.08
SPEEDWIRE:116:P	18K Yellow 33 Gauge (.18mm) 10ft. Spool	\$54.11
SPEEDWIRE:125:P	18K Yellow (Zinc-free) 28 Gauge (.32mm) 10ft. Spool	\$160.46
SPEEDWIRE:111:P	18K Yellow (Zinc-free) 30 Gauge (.26mm) 10ft. Spool	\$103.25
SPEEDWIRE:124:P	18K Yellow (Zinc-free) 33 Gauge (.18mm) 10ft. Spool	\$54.86
SPEEDWIRE:129:P	18K Yellow (Zinc-free) 33 Gauge (.18mm) 15ft. Spool	\$79.11
SPEEDWIRE:123:P	18K Yellow (Zinc-free) 36 Gauge (.13mm) 10ft. Spool	\$30.29
SPEEDWIRE:128:P	18K Yellow (Zinc-free) 36 Gauge (.13mm) 20ft. Spool	\$53.99
SPEEDWIRE:122:P	18K Rose 34 Gauge (.16mm) 10ft. Spool	\$42.39
SPEEDWIRE:134:P	19K White 30 Gauge (.26mm) 10ft. Spool	\$107.81
SPEEDWIRE:132:P	Silver Weld-Hard 30 Gauge (.26mm) 10ft. Spool	\$7.55
SPEEDWIRE:113:P	AGPD (Silver/Palladium) 30 Gauge (.26mm) 10ft. Spool	\$28.39
SPEEDWIRE:136:P	Continuum Sterling Silver 30 Gauge (.26mm) 10ft. Spool	\$9.46
SPEEDWIRE:137:P	Continuum Sterling Silver 36 Gauge (.13mm) 10ft. Spool	\$6.87
SPEEDWIRE:114:P	PT58 (.585 Platinum) 30 Gauge (.26mm) 10ft Spool	\$115.66
SPEEDWIRE:01180:	PLIR (Platinum/Iridium) 28 Gauge (.32mm) 10ft. Spool	\$223.26
SPEEDWIRE:011180:P	PLIR (Platinum/Iridium) 30 Gauge (.26mm) 10ft. Spool	\$144.15
SPEEDWIRE:131:P	PLIR (Platinum/Iridium) 33 Gauge (.18mm) 15ft. Spool	\$109.49
SPEEDWIRE:135:P	PLIR (Platinum/Iridium) 36 Gauge (.13mm) 20ft. Spool	\$75.00
SPEEDWIRE:115:P	PLRU (Platinum/Ruthenium) 30 Gauge (.26mm) 10ft. Spool	\$141.85
SPEEDWIRE:118:P	PLRU (Platinum/Ruthenium) 33 Gauge (.18mm) 10ft. Spool	\$75.58

**SPEEDWIRE™ DISPENSERS AND STAND**

Ever dreamed of the day when you'd feed laser wire into a weld with ease! Today, with the Speedwire dispenser system, you can do it. The Speedwire system features a specially designed dispenser with a finger-controlled feed. Use this one-handed operation to get in as close as 2mm from the weld. How's that for improving your accuracy? Each reloadable dispenser is able to hold a 10, 15, or 20 foot wire spool in its clear, sealed compartment. Monitor how much you've used while keeping it neat and clean. The wire feeds through a stainless steel guide for stability. No need to keep repositioning the wire to get it in just the right spot. The dispensers are color-coded so you can tell one metal from another. This is definitely a tool you won't want to live without.

Order #	Description	Jeweler's Cost
SPEEDWIRE:100:T	Dispenser Stand (Holds 8)	\$19.95
SPEEDWIRE:101:T	Reloadable Blue Dispenser for White Wire	\$23.00
SPEEDWIRE:102:T	Reloadable Red Dispenser for Yellow Wire	\$23.00
SPEEDWIRE:103:T	Reloadable White Dispenser for Silver Wire	\$23.00
SPEEDWIRE:104:T	Reloadable Purple Dispenser for Platinum/Palladium Wire	\$23.00
SPEEDWIRE:119:T	Repair Kit (Includes axle, wheel, spring, plunger, and guide tube)	\$6.00



All prices are priced at jeweler's cost based on \$1,400 gold, \$1,150 platinum, \$750 palladium, and \$20 silver and are subject to change without notice.



**PREFORM® SIZING STOCK**

Bulk Preform Sizing Stock is supplied in straight lengths with a medium hard temper unless otherwise requested. Available qualities will include 10K, 14K, 14X1®, 18K, and Sterlium Plus.

Profile	Ring Shank Thickness (mm)	Size Up	PREFORM BULK Approximate Pennyweight (dwt) Per Inch			PREFORM PRE-CUT Band width (Length) Approximate Price Per Piece Based on 14K Yellow Gold				
			10K	14K	18K	1.5mm	2mm	3mm	4mm	5mm
1	1	1/2 size (2.26mm)	0.38	0.43	0.51	\$1.18	\$1.64	\$2.46	\$3.28	\$4.09
1	1	1 size (3.5mm)	0.62	0.70	0.83	\$1.99	\$2.67	\$3.97	\$5.30	\$6.62
1	1	1.5 size (4.75mm)	0.86	0.97	0.51	\$2.75	\$3.66	\$5.49	\$7.32	\$9.15
1	1	2 size (6mm)	1.10	1.23	1.47	\$3.51	\$4.67	\$6.96	\$9.34	\$11.68
1	1	2.5 size (7.24mm)	1.35	1.51	1.80	\$4.30	\$5.73	\$8.60	\$11.46	\$14.33
1	1	3 size (8.43mm)	1.57	1.77	2.10	\$5.02	\$6.70	\$10.04	\$13.39	\$16.74
1	1	3.5 size (9.6mm)	1.83	2.06	2.45	\$5.85	\$7.80	\$11.70	\$15.61	\$19.51
1.2	1.2	1/2 size (2.46mm)	0.49	.557	0.66	\$1.58	\$2.11	\$3.13	\$4.22	\$5.27
1.2	1.2	1 size (3.7mm)	0.77	0.87	1.04	\$2.48	\$3.30	\$4.96	\$6.61	\$8.26
1.2	1.2	1.5 size (4.95mm)	1.05	1.18	1.41	\$3.36	\$4.34	\$6.72	\$8.96	\$11.20
1.2	1.2	2 size (6.2mm)	1.34	1.51	1.79	\$4.29	\$5.71	\$8.57	\$11.43	\$14.28
1.2	1.2	2.5 size (7.44mm)	1.62	1.82	2.17	\$5.18	\$6.91	\$10.36	\$13.81	\$17.27
1.2	1.2	3 size (8.56mm)	1.91	2.15	2.55	\$6.11	\$8.14	\$12.21	\$16.28	\$20.35
1.2	1.2	3.5 size (9.8mm)	2.16	2.43	2.89	\$6.92	\$9.22	\$13.83	\$18.44	\$23.05
1.5	1.5	1/2 size (2.77mm)	0.69	0.77	0.92	\$2.19	\$2.92	\$4.26	\$5.84	\$7.30
1.5	1.5	1 size (4mm)	1.03	1.16	1.38	\$3.30	\$4.40	\$6.70	\$8.80	\$11.00
1.5	1.5	1.5 size (5.26mm)	1.39	1.56	1.86	\$4.44	\$5.92	\$8.88	\$11.84	\$14.79
1.5	1.5	2 size (6.5mm)	2.00	2.25	2.68	\$5.11	\$7.42	\$11.13	\$14.90	\$21.33
1.5	1.5	2.5 size (7.75mm)	2.14	2.40	2.86	\$6.83	\$9.10	\$13.66	\$18.21	\$22.75
1.5	1.5	3 size (8.93mm)	2.48	2.79	3.32	\$7.94	\$10.57	\$15.87	\$21.17	\$26.45
1.5	1.5	3.5 size (10.1mm)	2.85	3.20	3.81	\$9.10	\$12.14	\$18.21	\$24.27	\$30.34
1.75	1.75	1/2 size (3mm)	0.85	0.95	1.13	\$2.70	\$3.60	\$5.40	\$7.21	\$9.01
1.75	1.75	1 size (4.25mm)	1.25	1.40	1.67	\$3.98	\$5.31	\$7.96	\$10.62	\$13.27
1.75	1.75	1.5 size (5.49mm)	1.71	1.92	2.28	\$5.46	\$7.28	\$10.92	\$14.57	\$18.21
1.75	1.75	2 size (6.76mm)	2.00	2.25	2.68	\$6.40	\$8.54	\$12.80	\$17.07	\$21.34
1.75	1.75	2.5 size (7.98mm)	2.60	2.92	3.47	\$8.31	\$11.08	\$16.62	\$22.16	\$27.70
1.75	1.75	3 size (9.24mm)	2.87	3.22	3.83	\$9.16	\$12.22	\$18.32	\$24.43	\$30.54
1.75	1.75	3.5 size (10.34mm)	3.40	3.82	4.55	\$10.87	\$14.49	\$21.73	\$28.98	\$36.22
2	2	1/2 size (3.25mm)	1.04	1.17	1.39	\$3.33	\$4.44	\$6.66	\$8.88	\$11.10
2	2	1 size (4.5mm)	1.52	1.71	2.03	\$4.87	\$6.48	\$9.73	\$12.97	\$16.21
2	2	1.5 size (5.75mm)	2.00	2.25	2.68	\$6.40	\$8.54	\$12.80	\$17.07	\$21.34
2	2	2 size (7.01mm)	2.49	2.80	3.33	\$7.96	\$10.62	\$15.92	\$21.23	\$26.54
2	2	2.5 size (8.23mm)	2.96	3.33	3.96	\$9.47	\$12.63	\$18.94	\$25.26	\$31.57
2	2	3 size (9.49mm)	3.52	3.95	4.70	\$11.24	\$14.98	\$22.47	\$29.96	\$37.45
2	2	3.5 size (10.6mm)	3.96	4.45	5.30	\$12.66	\$16.88	\$25.32	\$33.76	\$42.20

Pre-cut Preform sizing stock is pre-measured to size rings 1/2 size to 3 1/2 sizes up. This sizing stock comes in 1/2 size increments with a choice of 1 1/2mm, 2mm, 3mm, 4mm, and 5mm pre-cut lengths.



Minimum order for bulk-Gold 1 inch. Sterling Silver 12 inches.

Maximum straight length for bulk is 36 inches. Minimum order for precut is number of pieces to equal 1 inch.

Preform® Sizing Stock	Approximate Pricing Per Pennyweight (dwt)		
	1 dwt	50 dwt	100 dwt
10K Yellow or White	\$36.64	\$34.78	\$34.47
14K Yellow or White	\$48.22	\$46.35	\$46.04
18K Yellow or White	\$60.12	\$58.25	\$57.94
Sterlium Plus®	\$2.25	\$2.21	\$2.19



100% Recycled Gold and Silver. Visit [Stuller.com/SensibleSourcing](http://Stuller.com/SensibleSourcing) for more information.

**FLAT SIZING STOCK**

Flat sizing stock is offered in straight lengths with 1/2 hard temper unless otherwise requested. Annealing is available upon request.

	Profile	Size (mm)	Minimum Order	Approximate Pennyweights (dwt) Per Inch					
				10K	14K	18K	Plat/Ru	.950 Pd	Sterlium Plus™
1.5x	—	1.5x.75	3"	0.20	0.24	0.28	0.38	0.21	0.19
	—	1.5x1	3"	0.28	0.30	0.38	0.51	0.29	0.26
2x	—	2x.75	3"	0.29	0.32	0.35	0.51	0.29	0.26
	—	2x1	3"	0.37	0.41	0.52	0.68	0.38	0.35
2.5x	—	2.5x1.25	3"	0.49	0.54	0.64	0.85	0.48	0.42
	—	2.5x1.5	3"	0.56	0.63	0.71	1.01	0.58	0.51
2.5x	—	2.5x.75	3"	0.29	0.39	0.44	0.63	0.35	0.32
	—	2.5x1	3"	0.46	0.53	0.62	0.85	0.48	0.43
2.5x	—	2.5x1.25	1"	0.56	0.63	0.75	1.06	0.60	0.51
	—	2.5x1.5	1"	0.68	0.79	0.91	1.27	0.68	0.64
2.5x	—	2.5x2	1"	0.89	1.05	1.22	1.69	0.97	0.83
	—	3x.75	1"	0.40	0.50	0.57	0.76	0.44	0.37
3x	—	3x1	1"	0.56	0.63	0.76	1.01	0.57	0.50
	—	3x1.25	1"	0.68	0.78	0.93	1.27	0.73	0.63
3x	—	3x1.5	1"	0.82	0.94	1.12	1.52	0.87	0.74
	—	3x2	1"	1.12	1.26	1.49	2.03	1.16	1.25
3x	—	3x2.5	1"	1.35	1.50	1.83	2.54	1.45	1.49
	—	3.5x1	1"	0.68	0.73	0.88	1.18	1.02	0.62
3.5x	—	3.5x1.5	1"	0.92	1.11	1.35	1.77	1.02	0.88
	—	3.5x2	1"	1.31	1.45	1.74	2.37	1.35	1.25
3.5x	—	3.5x2.5	1"	1.45	1.85	2.20	2.96	1.69	1.49
	—	4x.75	1"	0.58	0.62	0.75	1.01	0.65	0.57
4x	—	4x1	1"	0.76	0.84	1.00	1.35	0.76	0.65
	—	4x1.25	1"	0.95	1.04	1.28	1.69	1.09	0.82
4x	—	4x1.5	1"	1.12	1.26	1.51	2.03	1.13	0.98
	—	4x2	1"	1.49	1.68	1.93	2.70	1.74	1.32
4x	—	4x2.25	1"	1.69	1.96	2.21	3.04	1.96	1.68
	—	4x3	1"	2.17	2.69	2.98	4.06	2.61	2.10
4.5x	—	4.5x1	1"	0.86	0.95	—	1.52	0.87	0.75
	—	4.5x1.5	1"	1.22	1.44	1.67	2.28	1.31	1.15
4.5x	—	4.5x2	1"	1.65	1.89	2.25	3.04	1.74	1.58
	—	5x.75	1"	0.74	0.79	0.99	1.27	0.73	0.68
5x	—	5x1	1"	0.94	1.07	1.27	1.69	0.95	0.81
	—	5x1.25	1"	1.16	1.33	1.56	2.11	1.21	1.05
5x	—	5x1.5	1"	1.40	1.58	1.85	2.54	1.45	1.24
	—	5x2	1"	1.86	2.11	2.51	3.38	1.89	1.67
5x	—	5x2.5	1"	2.26	2.59	3.13	4.23	2.42	2.22
	—	6x1	1"	1.11	1.24	1.48	2.03	1.16	1.01
6x	—	6x1.5	1"	1.65	1.89	2.28	3.04	1.74	1.51
	—	6x2	1"	2.24	2.53	2.98	4.06	2.32	1.93
6x	—	6x2.5	1"	2.93	3.15	3.80	5.07	2.84	2.62
	—	7x1	1"	1.31	1.52	1.73	2.37	1.35	1.23
7x	—	7x1.5	1"	1.97	2.21	2.63	3.55	2.03	1.75
	—	7x2	1"	2.54	2.95	3.43	4.73	2.65	2.49
7x	—	7x2.5	1"	3.44	3.71	4.43	5.92	3.39	3.09
	—	8x1	1"	1.52	1.72	2.08	2.70	1.55	1.33
8x	—	8x1.5	1"	2.21	2.48	2.96	3.32	2.32	2.05
	—	8x2	1"	2.92	3.33	3.85	5.41	3.10	2.58
8x	—	8x2.5	1"	3.67	4.12	5.06	6.76	3.78	3.29
	—	10x1	1"	1.85	2.11	2.50	3.38	1.94	1.77
10x	—	10x1.5	1"	2.75	3.17	3.83	5.07	2.90	2.54



In order to determine what size best fits your needs, you must first measure the width, then the thickness.

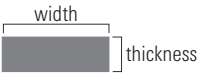

Flat Sizing Stock	Approximate Pricing		
	1 dwt	50 dwt	100 dwt
10K Yellow or White	\$35.64	\$33.78	\$33.47
14K Yellow or White	\$47.22	\$45.35	\$45.04
18K Yellow or White	\$59.12	\$57.25	\$56.94
.950/.05			
Platinum/Ruthenium	\$63.09	\$62.04	\$61.92
Palladium	\$43.88	\$42.83	\$42.71

Silver Flat Sizing Stock Sterlium Plus™					
Approximate Pricing					
1 dwt	1 oz	400 dwt	20 oz	1000 dwt	50 oz
\$1.50	\$28.00	\$1.43	\$26.40	\$1.40	\$25.80

Maximum straight length is 36 inches.

Minimum order for Sterling Silver is 12 inches per size.

STULLER METALS CLUB

Call 877-619-2173 to join the Metals Club and start saving today.





**Half-Round Sizing Stock** is supplied in straight lengths with a 1/2 hard temper unless otherwise requested. Coiled sizing stock can be made-to-order with additional lead times. Annealing is available upon request.



In order to determine what size best fits your needs, you must first measure the width, then the thickness.

LEAD TIMES: 10K yellow, 14K yellow, 14K white, 18K yellow and sterling silver will ship same day in most cases. Back orders will ship the following day. All other metal qualities are MTO (made to order) and will ship within three working days in most cases. Same-day shipping subject to order specifications, special request, and inventory on hand at time of order. Additional charges and lead times may apply to odd quantities.

Maximum straight length is 36 inches.

Minimum order for Sterling Silver is 12 inches per size.

**HALF-ROUND SIZING STOCK**

	Profile	Width x Thickness (mm)	Minimum Order	Approximate Pennyweights (dwt) Per Square Inch				
				10K	14K	18K	Plat/Ru	Sterilum Plus®
1x	-	1x.5	3"	0.10	0.11	0.13	0.18	0.09
1.5x	-	1.5x.75	3"	0.24	0.23	0.27	0.33	0.18
	-	1.5x1	3"	0.24	0.27	0.42	0.47	0.21
1.75x	-	1.75x1	3"	0.33	0.32	0.38	0.64	0.21
2x	-	2x1	3"	0.32	0.38	0.51	0.56	0.31
	-	2x1.5	1"	0.50	0.63	0.70	0.97	0.50
2.25x	-	2.25x1.5	1"	0.58	0.67	0.73	1.09	0.47
	-	2.5x1.25	1"	0.53	0.58	0.69	0.92	0.42
2.5x	-	2.5x1.5	1"	0.63	0.73	0.83	1.17	0.54
	-	2.5x2	1"	0.88	0.98	1.11	1.53	0.70
3x	-	3x1	1"	0.51	0.56	0.68	0.77	0.37
	-	3x1.5	1"	0.74	0.83	1.01	1.35	0.67
	-	3x2	1"	0.98	1.11	1.34	1.83	0.84
3.5x	-	3.5x1.5	1"	0.92	0.90	1.08	1.51	0.77
	-	3.5x2	1"	1.13	1.23	1.51	2.07	1.02
4x	-	4x1	1"	0.55	0.61	0.73	1.01	0.55
	-	4x1.5	1"	0.90	1.08	1.22	1.66	0.86
	-	4x2	1"	1.18	1.44	1.66	2.39	1.18
4.5x	-	4.5x1.5	1"	1.03	1.11	1.71	1.89	0.93
	-	4.5x2	1"	1.47	1.57	1.85	2.55	1.26
5x	-	5x1	1"	0.93	0.95	0.93	1.29	0.75
	-	5x1.5	1"	1.13	1.27	1.54	2.11	1.02
	-	5x2	1"	1.52	1.77	2.11	2.92	1.37
	-	5x2.5	1"	2.02	2.16	2.53	4.00	1.76
	-	5x3	1"	-	2.66	3.32	4.33	2.12
6x	-	6x1	1"	0.94	1.05	1.25	1.74	0.83
	-	6x1.25	1"	1.24	1.32	1.52	2.31	1.08
	-	6x1.5	1"	1.26	1.49	1.78	2.52	1.13
	-	6x2	1"	1.80	2.06	2.48	3.29	1.60
	-	6x2.5	1"	2.25	2.54	3.06	4.16	2.08
	-	6x3	1"	2.77	3.20	3.83	5.32	2.52
7x	-	7x1	1"	1.15	1.29	1.54	2.13	1.02
	-	7x1.5	1"	1.38	1.90	2.05	2.83	1.41
	-	7x2	1"	2.03	2.41	2.88	4.15	1.83
	-	7x2.5	1"	2.68	3.11	3.48	4.58	2.35
8x	-	8x1.25	1"	1.59	1.69	1.98	2.97	1.40
	-	8x1.5	1"	1.69	2.02	2.42	3.17	1.50
	-	8x1.7	1"	2.13	2.35	2.79	3.97	1.88
	-	8x2	1"	2.27	2.79	3.18	4.22	2.03
10x	-	10x1.25	1"	2.04	2.27	2.96	3.80	1.77
12x	-	12x1.5	1"	2.75	3.01	3.57	5.12	2.42
	-	12x1.7	1"	3.19	3.60	4.15	5.95	2.80
15x	-	15x1.7	1"	4.07	4.58	5.28	7.71	3.58
18x	-	18x1.7	1"	4.85	5.46	6.29	9.02	4.27

Half-Round Sizing Stock	Approximate Pricing Per Pennyweight (dwt)		
	1 dwt	50 dwt	100 dwt
10K Yellow or White	\$35.64	\$33.78	\$33.47
14K Yellow or White	\$47.22	\$45.35	\$45.04
18K Yellow or White	\$59.12	\$57.25	\$56.94
.950/.05 Platinum/Ruthenium	\$63.09	\$62.04	\$61.92

Half-Round Sizing Stock Sterilum Plus®					
Approximate Pricing Per Pennyweight (dwt)/Ounce (oz)					
1 dwt	1 oz	400 dwt	20 oz	1000 dwt	50 oz
\$1.50	\$28.00	\$1.43	\$26.40	\$1.40	\$25.80



100% Recycled Gold and Silver. Visit [Stuller.com/SensibleSourcing](http://Stuller.com/SensibleSourcing) for more information.

Prices based on \$1,300 gold, \$1,400 platinum, \$900 palladium and \$18 silver.

**COMFORT FIT SIZING STOCK**

Perfect for fabricating comfort-fit rings and sizing comfort-fit bands. Supplied in straight lengths with 1/2 hard temper unless otherwise requested. Coiled sizing stock can be made-to-order with additional lead times. Annealing is available upon request.

Profile	Size (mm)	Minimum Order	Approximate Pennyweights (dwt) Per Inch				
			10K	14K	18K	Plat/Ru	Sterilum Plus™
●	3x2	1"	0.98	1.11	1.32	1.81	0.87
●	4x2	1"	1.27	1.43	1.70	2.34	1.13
●	5x2	1"	1.53	1.72	2.05	2.83	1.36
●	6x2	1"	1.80	2.02	2.40	3.31	1.61

Maximum straight length is 36 inches.

Comfort-Fit Sizing Stock	Approximate Pricing Per Pennyweight (dwt)		
	1 dwt	50 dwt	100 dwt
10K Yellow or White	\$35.64	\$33.78	\$33.47
14K Yellow or White	\$47.22	\$45.35	\$45.04
18K Yellow or White	\$59.12	\$57.25	\$56.94
.950/.05 Platinum/Ruthenium	\$63.09	\$62.04	\$61.92

Silver Comfort-Fit Sizing stock Sterilum Plus®	Approximate Pricing Per Pennyweight (dwt)/Ounce (oz)				
	1 dwt	1 oz	400 dwt	20 oz	1000 dwt 50 oz
	\$1.50	\$28.00	\$1.43	\$26.40	\$1.40 \$25.80

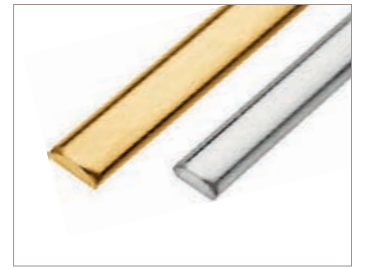

In order to determine what size best fits your needs, you must first measure the width, then the thickness.

**STERLING SILVER LOW DOME WIRE**

Sterling silver low dome wire is particularly designed to eliminate the sharp edges on conventional half-round wires. Excellent for making bangle bracelets and rings. Supplied soft and coiled.

Profile	Width x Thickness (mm)	Thickness (inches)	Minimum Order	Approximate dwt/ft.	20 dwt (1 oz.) Length (inch)	100 dwt (5 oz.) Length (feet)
●	5x2	.197x.080	6"	17.3	14	5.8
●	6x1.7	.236x.067	6"	17.3	14	5.8
●	6x2	.236x.080	6"	20.8	12	4.8
●	8x1.7	.315x.067	6"	23.1	10	4.3
●	8x2	.315x.080	6"	27.8	9	3.6
●	10x1.7	.394x.067	6"	28.8	8	3.5
●	10x2	.394x.080	6"	34.7	7	2.9
●	12x2	.472x.080	6"	41.6	6	2.4

Low Dome Wire Sterling Silver	Approximate Pricing Per Pennyweight (dwt)/Ounce (oz)				
	1 dwt	1 oz	400 dwt	20 oz	1000 dwt 50 oz
	\$1.46	\$27.00	\$1.38	\$25.40	\$1.35 \$24.80



In order to determine what size best fits your needs, you must first measure the width, then the thickness.

**YELLOW GOLD-FILLED HALF ROUND WIRE**

1/20 14K Yellow Gold-Filled half-round wire is supplied soft, or half hard as noted below.

Profile	Gauge	Width x Thickness (mm)	Thickness (Inches)	Minimum Order	Approximate dwt/ft.	20 dwt (1 oz.) Length (inch)	Available Temper
-	18	1.02x0.51	.040x.020	60"	0.84	286.0	Half-Hard
●	8	3.25x1.63	.128x.064	6"	7.44	32.0	Soft

YGF Half-Round Wire 1/20 14K Yellow Gold Filled	Approximate Pricing Per Pennyweight (dwt)/Ounce (oz)				
	1 dwt	1 oz	50 dwt	25 oz	100 dwt 50 oz
	\$3.83	\$73.00	\$3.36	\$63.80	\$3.22 \$60.80

STULLER METALS CLUB

Call 877-619-2173 to join the Metals Club and start saving today.

All prices are priced at jeweler's cost based on \$1,400 gold, \$1,150 platinum, \$750 palladium, and \$20 silver and are subject to change without notice. Visit [Stuller.com](http://Stuller.com) for our complete product selections, current pricing, and quantity price breaks. | 371



**SQUARE SIZING STOCK**

Profile	Size (mm)	Minimum Order	Approximate Pennyweights (dwt) Per Inch					
			10K	14K	18K	Plat/Ru	Palladium	Sterlium Plus™
■	.75x.75	3"	0.11	0.12	0.14	0.19	—	0.09
■	1x1	3"	0.19	0.21	0.25	0.34	0.19	0.17
■	1.25x1.25	3"	0.30	0.35	0.38	0.53	0.30	0.26
■	1.5x1.5	3"	0.42	0.47	0.55	0.76	0.43	0.38
■	1.75x1.75	1"	0.58	0.67	0.76	1.04	0.58	0.53
■	2x2	1"	0.76	0.83	1.03	1.45	0.76	0.70
■	2.25x2.25	1"	0.85	1.05	1.28	1.71	0.96	0.88
■	2.5x2.5	1"	1.15	1.31	1.62	2.11	1.18	1.03
■	3x3	1"	1.72	1.83	2.25	3.04	1.70	1.52
■	3.5x3.5	1"	2.30	2.48	2.88	4.14	2.32	1.87
■	4x4	1"	3.01	3.28	3.95	5.41	3.03	2.63
■	5x5	1"	4.84	5.06	6.19	8.45	—	4.26
■	6x6	1"	6.94	7.51	9.14	12.17	6.81	6.11

Square Sizing Stock	Approximate Pricing Per Pennyweight (dwt)		
	1 dwt	50 dwt	100 dwt
10K Yellow	\$35.64	\$33.78	\$33.47
14K Yellow	\$47.22	\$45.35	\$45.04
18K Yellow	\$59.12	\$57.25	\$56.94
.950/.05 Platinum/Ruthenium	\$63.09	\$62.04	\$61.92
Palladium	\$43.88	\$42.83	\$42.71
Sterlium Plus®	\$1.50	\$1.46	\$1.44

Square Sizing Stock is offered in straight lengths with 1/2 hard temper unless otherwise requested. Coiled sizing stock can be made-to-order with additional lead times. Annealing is available upon request.

Maximum length is 36 inches.

Minimum order for sterling silver is 12 inches per size.



**STERLING SILVER SQUARE WIRE**

Profile	Gauge	mm	Inch	Minimum Order	Approximate dwt/ft.	20 dwt (1 oz.) Length (inch)	100 dwt (5 oz.) Length (feet)	Available Temper
■	22	0.64mm	.025"	60"	0.84	286"	119.0'	Soft
■	20	0.81mm	.032"	36"	1.32	182"	75.80'	1/2 Hard
■	18	1.02mm	.040"	24"	2.16	111"	46.3'	1/2 Hard
■	12	2.05mm	.080"	12"	8.40	29"	11.9'	Soft
■	8	3.26mm	.128"	6"	21.48	11"	4.7'	Soft

Silver Square Wire	Approximate Pricing Per Pennyweight (dwt)/Ounce (oz)					
	1 dwt	1 oz	400 dwt	20 oz	1000 dwt	50 oz
Sterling Silver	\$1.53	\$28.50	\$1.46	\$27.00	\$1.43	\$26.40

Sterling Silver Square Wire is available coiled in soft and half-hard tempers as listed below.

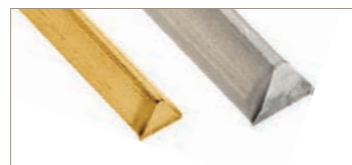

**TRIANGLE SIZING STOCK**

Profile	Size (mm)	Minimum Order	Approximate Pennyweights (dwt) Per Inch			
			10K	14K	18K	Plat/Ru
▲	2x1.75	1"	0.33	0.44	0.42	0.72
▲	4x3.5	1"	1.33	1.50	1.71	2.36
▲	6x5.5	1"	3.00	3.38	3.88	5.58
▲	8x7	1"	5.29	5.96	6.88	9.46

Triangle Sizing Stock	Approximate Pricing Per Pennyweight (dwt)		
	1 dwt	50 dwt	100 dwt
10K Yellow	\$35.64	\$33.78	\$33.47
14K Yellow	\$47.22	\$45.35	\$45.04
18K Yellow	\$59.12	\$57.25	\$56.94
.950/.05 Platinum/Ruthenium	\$63.09	\$62.04	\$61.92

Triangle Sizing Stock is supplied in straight lengths with medium hard temper, unless otherwise requested.

Maximum straight length is 36 inches.

In order to determine what size best fits your needs, you must first measure the width, base, and height.

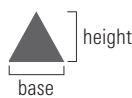

**FLAT BEZEL STOCK**

	Profile	Width Size (mm)	Thickness Gauge	Minimum Order	Approximate Pennyweights (dwt) Per Inch			
					10K	14K	18K	Plat/Ru
2x	—	2mm	22	12"	0.24	0.27	0.33	0.45
	—	2mm	24	12"	0.19	0.22	—	0.36
	—	2mm	26	12"	0.16	0.18	0.21	0.29
	—	2mm	28	12"	0.13	0.14	0.17	0.23
	—	2mm	30	12"	0.10	0.11	0.13	0.18
3x	—	3mm	22	6"	0.37	0.41	0.49	0.68
	—	3mm	24	6"	—	0.33	0.39	0.54
	—	3mm	26	6"	0.23	0.26	0.31	0.43
	—	3mm	28	6"	0.19	0.20	0.25	0.35
	—	3mm	30	6"	0.15	0.16	0.20	0.27
4x	—	4mm	22	6"	0.65	0.55	0.65	0.90
	—	4mm	24	6"	0.52	0.44	0.52	0.72
	—	4mm	26	6"	0.31	0.35	0.42	0.58
	—	4mm	28	6"	0.25	0.28	0.34	0.47
	—	4mm	30	6"	0.19	0.22	0.26	0.36
5x	—	5mm	22	6"	0.61	0.68	0.81	1.13
	—	5mm	24	6"	0.49	—	—	0.90
	—	5mm	26	6"	0.39	0.44	0.52	0.72
	—	5mm	28	6"	0.32	0.36	0.42	0.59
	—	5mm	30	6"	0.24	0.27	0.33	0.45
6x	—	6mm	22	6"	0.73	0.82	0.98	1.35
	—	6mm	24	6"	0.58	0.66	0.78	1.08
	—	6mm	26	6"	0.47	0.52	—	0.87
	—	6mm	28	6"	0.38	0.43	—	0.70
	—	6mm	30	6"	0.29	0.33	0.39	0.54



Flat bezel strips are supplied with a 3/4 hard temper. Annealing is available upon request. For strips more than 6mm wide, see flat strip.

Flat Bezel	Approximate Pricing		
	1 dwt	50 dwt	100 dwt
10K Yellow or White	\$35.75	\$33.85	\$33.53
14K Yellow or White	\$47.33	\$45.43	\$45.11
18K Yellow or White	\$59.22	\$57.33	\$57.01
.950/.05 Platinum/Ruthenium	\$63.09	\$62.04	\$61.92

**STEPPED BEZEL STOCK**

Bezel wire is available in 14K gold and sterling silver.

Style	Thickness x Width x Height (mm)	Thickness x Width x Height (inches)	Approximate Pennyweights (dwt)	
			Per Square Inch	Per Foot Sterling
Milgrain	0.29x1.08x2.5	.011x.042x.098	0.35	3.29
Plain Step	0.23x0.86x2.45	.009x.034x.096	0.27	2.18
Plain Step	0.27x0.78x5.56	.011x.001x.022	0.51	4.78

Stepped Bezel Stock	Approximate Pricing Per Pennyweight (dwt)		
	1 dwt	50 dwt	100 dwt
14K Yellow or White	\$47.33	\$45.43	\$45.11
Sterling Silver	\$1.45	\$1.35	\$1.34



Minimum order is 3 inches for gold. Sterling silver bezel is supplied in 12 inch lengths.

Item #1 Milgrain on Top Edge

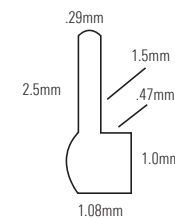

Item #2

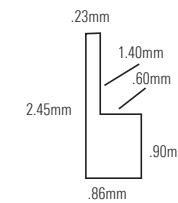

Item #3

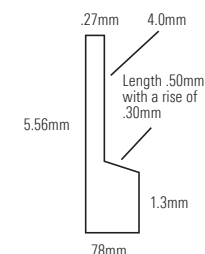

STULLER METALS CLUB

Call 877-619-2173 to join the Metals Club and start saving today.





Seamless round tubing is available in all sizes listed for 14K yellow and 14K palladium-white. Selected sizes are available in other qualities and supplied in straight lengths with a medium-hard temper.

Sterlium Plus round tubing is available in 12" lengths only. Supplied in soft temper, straight lengths, and stress-relieved.

**GOLD ROUND TUBING**

	Profile	Outside Diameter		Inside Diameter		Minimum Order	Approximate Pennyweights			Insert Wire (gauge)
		(mm)	(inch)	(mm)	(inch)		14K	18K	Sterlium Plus®	
<b>Light .010" 30 ga</b>	◦	1 L	.039"	0.50	.020"	3"	0.13	0.16	1.15	25
	◦	1.13 L	.044"	0.63	.025"	3"	1.15	0.18	1.21	23
	◦	1.25 L	.049"	0.75	.030"	3"	0.13	0.21	1.49	21
	◦	1.43 L	.056"	0.93	.037"	1"	0.19	0.23	1.82	20
	◦	1.6 L	.063"	1.10	.043"	1"	0.21	0.25	2.14	18
	◦	1.8 L	.071"	1.30	.051"	1"	0.23	0.29	2.51	17
	○	2.05 L	.081"	1.55	.061"	1"	0.31	0.37	2.92	15
	○	2.25 L	.089"	1.75	.069"	1"	0.34	0.41	3.25	14
	○	2.55 L	.100"	2.05	.081"	1"	0.38	0.46	3.53	13
<b>Medium .015" 26 ga</b>	○	2.85 L	.112"	2.35	.093"	1"	0.46	0.55	4.00	12
	○	3.13 L	.123"	2.63	.103"	1"	0.48	0.60	4.65	10
	○	2 M	.079"	1.20	.047"	1"	0.41	–	3.80	16
	○	2.5 M	.098"	1.70	.067"	1"	0.53	0.60	4.65	14
	○	3 M	.118"	2.20	.087"	1"	0.71	0.86	6.01	12
	○	3.3 M	.130"	2.50	.098"	1"	0.75	–	7.50	11
	○	3.56 M	.140"	2.76	.109"	12"	–	–	7.80	10
	○	3.75 M	.148"	2.95	.116"	1"	0.88	1.06	7.45	9
	○	4.06 M	.160"	3.26	.128"	12"	–	–	9.00	8
<b>Heavy .020" 24 ga</b>	○	4.8 M	.189"	4.00	.157"	1"	1.09	1.31	11.38	7
	○	5.08 M	.200"	4.28	.169"	12"	–	–	11.90	6
	○	5.8 M	.228"	5.00	.197"	1"	1.38	1.66	12.45	5
	○	6.09 M	.240"	5.29	.208"	12"	–	–	14.50	4
	○	2 H	.079"	1.00	.039"	1"	0.49	0.59	4.85	19
	○	2.25 H	.089"	1.25	.049"	1"	0.54	0.65	5.56	17
	○	2.5 H	.098"	1.50	.059"	1"	0.64	0.77	5.30	15
	○	2.85 H	.112"	1.85	.073"	1"	0.75	0.90	6.65	14
	○	3.13 H	.123"	2.13	.084"	1"	0.87	1.06	8.30	12
<b>Extra Heavy .025" 22 ga</b>	○	3.5 H	.138"	2.50	.098"	1"	1.02	1.22	9.07	11
	○	4 H	.157"	3.00	.118"	1"	1.23	1.48	11.02	9
	○	4.25 H	.167"	3.25	.128"	1"	1.33	–	11.83	8
	○	4.5 H	.177"	3.50	.138"	1"	1.35	1.62	12.63	8
	○	6.35 H	.250"	5.35	.211"	12"	–	–	19.20	–
<b>Extra Heavy .025" 22 ga</b>	○	5.1 X	.201"	3.83	.151"	1"	1.75	–	–	7
	○	5.5 X	.217"	4.23	.167"	1"	–	2.27	–	6
	○	6.5 X	.256"	5.23	.206"	1"	2.52	–	–	3

Round Tubing	Approximate Pricing Per Pennyweight (dwt)		
	1 dwt	50 dwt	100 dwt
14K Yellow	\$49.47	\$47.73	\$47.48
18K Yellow	\$61.37	\$59.63	\$59.38

Silver Round Tubing Sterlium Plus®	Approximate Pricing Per Pennyweight (dwt)/Ounce (oz)				
	1 dwt	1 oz	400 dwt	20 oz	1000 dwt 50 oz
	\$1.80	\$202.20	\$1.67	\$186.80	\$1.62 \$181.60



Wedding Band Fabrication and Design Made Seamless



Wedding bands mean big business. With more than two million weddings taking place every year, they double up to play a central role.

And with Stuller as your partner, you've got everything you need to establish your store as the place for bands. Now, you can purchase wedding bands at any step of the process.

We manufacture tubing and ring blanks here for use in our wedding band fabrication process. It starts with recycled grain. Then it is cast and drawn to the finger size needed. From this, ring blanks are cut to the widths specified.

From the stock bands that are ready to deliver profits to raw tubing and ring blanks to drive your custom business, they are made from here from start to finish. And speaking of finishing, we can take it to whatever level you'd like. We can ship it raw, polish it, or add a special finish. The choice is yours. It's never been easier to create custom bands for your customers.

Metal qualities include—  
Sterlium Plus, 10K, 14K, and 18K red, white, and yellow gold. Convenient ordering is available by millimeter size or inches with only a one millimeter minimum.

Available sizes are—  
Finger size 3 through 15 in ¼, ½ and ¾ increments.





**SLIT COIL**

Sterlium Plus® slit coiled wire is supplied with a dead soft temper in continuous lengths. Larger orders may receive multiple coils.

Profile	Width x Thickness (mm)		Minimum Order	Approximate dwt/ft.	20 dwt (1 oz.) 100 dwt (5 oz.) Length (inch) Length (ft)		Approximate Price	
		(inches)			1 dwt	100 dwt		
—	3.18x.51	1/8"x.020"	36"	3.28	73"	30.48'	\$1.68	\$1.64
—	6.35x.51	1/4"x.020"	24"	6.55	37"	15.27'	\$1.68	\$1.64
—	9.52x.51	3/8"x.020"	12"	9.82	24"	10.18'	\$1.68	\$1.64
—	12.7x.51	1/2"x.020"	12"	13.10	18"	7.63'	\$1.68	\$1.64
—	15.88x.51	5/8"x.020"	12"	16.38	15"	6.11'	\$1.68	\$1.64

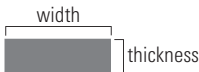

In order to determine what size best fits your needs, you must first measure the width, then the thickness.

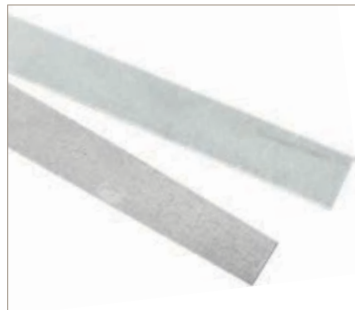

**FINE SILVER BEZEL**

Flat bezel is supplied with a dead soft temper and coiled.

Profile	Shape	Gauge	Width x Thickness (mm)		Minimum Order (inches)	Approximate dwt/ft.	Approximate Price	
				(inches)			1 dwt	100 dwt
—	Flat	30	4.76x0.255	3/16"x.010"	24"	.21	\$1.61	\$1.55
—	Flat	30	3.18x0.255	1/8"x.010"	48"	.1389	\$1.61	\$1.55
—	Flat	30	2.38x0.255	3/32"x.010"	60"	.1036	\$1.61	\$1.55
—	Flat	28	4.76x0.321	3/16"x.012"	24"	.25	\$1.61	\$1.55
—	Flat	28	3.18x0.321	1/8"x.012"	36"	.16	\$1.61	\$1.55
—	Flat	28	2.38x0.321	3/32"x.012"	48"	.13	\$1.61	\$1.55
—	Flat	26	3.18x0.405	1/8"x.016"	24"	.2207	\$1.61	\$1.55



**STERLING SILVER DIAMOND-CUT WIRE**

This amazing sterling silver wire sparkles just like a diamond-cut chain. Great for making earrings, neck wires, and more. Supplied in dead soft temper and coiled.

Profile	Gauge	Outside Diameter (mm)		Minimum Order	Approximate dwt/ft.	Approximate Price	
			(inches)			1 dwt	100 dwt
•	18	1.02	.04"	36"	1.68	\$1.45	\$1.41
•	16	1.29	.05"	36"	2.28	\$1.45	\$1.41
•	14	1.63	.06"	36"	3.38	\$1.45	\$1.41



**STERLING SILVER TWISTED WIRE**

Twisted wire is made by twisting round wire of the same diameter together. Supplied in dead soft temper and coiled.

Profile	Gauge	Outside Diameter (mm)		Minimum Order	Approximate dwt/ft.	Approximate Price	
			(inches)			1 dwt	100 dwt
•	18	1.02	.04"	60"	0.84	\$1.45	\$1.41
•	14	1.63	.067"	36"	2.64	\$1.45	\$1.41
•	12	2.05	.084"	24"	3.96	\$1.45	\$1.41
•	10	2.58	.102"	12"	6.60	\$1.45	\$1.41

**SILVER PATTERN WIRE**

Sterling silver pattern wire is supplied soft and coiled.

Profile	Style #	Millimeter Width x Thickness	Approximate dwt (feet)	Approximate Price	
				1 dwt	100 dwt
	SS-210	7.63x1.24	13.80	\$1.45	\$1.41
	SS-211	4.13x1.35	8.40	\$1.45	\$1.41
	SS-212	4.7x1.5	9.00	\$1.45	\$1.41
	SS-213	5.35x1.47	11.76	\$1.45	\$1.41
	SS-214	5.67x1.33	10.80	\$1.45	\$1.41
	SS-215	2.4x1.45	4.80	\$1.45	\$1.41
	SS-216	2.04x1.28	3.84	\$1.45	\$1.41
	SS-217	2.85x1.5	6.00	\$1.45	\$1.41
	SS-218	2.42x1.27	4.44	\$1.45	\$1.41
	SS-219	1.55x1.35	3.36	\$1.45	\$1.41
	SS-240	2.6x0.55	2.20	\$1.45	\$1.41
	SS-242	3.67x1.1	7.44	\$1.45	\$1.41
	SS-244	6.45x0.88	7.20	\$1.45	\$1.41
	SS-245	6.35x1.58	14.16	\$1.45	\$1.41
	SS-246	3.54x1.4	7.68	\$1.45	\$1.41
	SS-247	3.45x1.35	7.20	\$1.45	\$1.41
	SS-249	19x0.87	31.39	\$1.45	\$1.41
	SS-250	9.55x1.3	24.00	\$1.45	\$1.41
	SS-402	5.6x2.6	11.88	\$1.45	\$1.41

Minimum order is 12 inches per size.

STULLER METALS CLUB | Call 877-619-2173 to join the Metals Club and start saving today.





**GOLD PLUMB SOLDER SHEET**

**CADMIUM-BEARING**

These karat gold sheet solders contain cadmium to improve solder flow characteristics, and are supplied in one pennyweight sheets.

**WARNING**  
Cadmium-bearing solders contain chemicals known to cause cancer, birth defects, and other health-related problems.

Solder Quality	Melting Point (°F)	Flow Point (°F)	Approximate Price Per Pennyweight (dwt)		
			1 dwt	50 dwt	100 dwt
6K Yellow, Easy	1165° F	1220° F	\$24.92	\$22.84	\$22.49
8K Yellow, Easy	1150° F	1230° F	\$30.77	\$28.68	\$28.34
10K Yellow, Easy	1170° F	1240° F	\$36.36	\$34.28	\$33.93
10K Yellow, Medium	1230° F	1285° F	\$36.36	\$34.28	\$33.93
10K Yellow, Hard	1310° F	1360° F	\$36.36	\$34.28	\$33.93
12K Yellow, Easy	1070° F	1165° F	\$42.18	\$40.10	\$39.75
14K Yellow, Ultra Easy	1070° F	1165° F	\$48.02	\$45.94	\$45.59
14K Yellow, Easy	1180° F	1320° F	\$48.02	\$45.94	\$45.59
14K Yellow, Medium	1230° F	1360° F	\$48.02	\$45.94	\$45.59
14K Yellow, Hard	1410° F	1460° F	\$48.02	\$45.94	\$45.59
18K Yellow, Easy	1155° F	1255° F	\$59.79	\$57.71	\$57.36
18K Yellow, Hard	1480° F	1550° F	\$59.79	\$57.71	\$57.36
21K Yellow, Hard	1545° F	1625° F	\$68.30	\$66.22	\$65.87
6K White, Easy	1220° F	1230° F	\$25.54	\$23.46	\$23.11
10K White, Easy	1250° F	1290° F	\$37.17	\$35.08	\$34.74
14K White, Easy	1235° F	1275° F	\$48.62	\$46.54	\$46.19
14K White, Hard	1330° F	1380° F	\$48.62	\$46.54	\$46.19
14K Rose, Weld	1588° F	1661° F	\$48.39	\$46.31	\$45.96
18K Rose, Medium	1395° F	1505° F	\$60.23	\$58.15	\$57.80
14K Green, Medium	1390° F	1425° F	\$48.55	\$46.47	\$46.12
18K Green, Medium	1510° F	1545° F	\$60.43	\$58.35	\$58.00

**GOLD PLUMB SOLDER SHEET**

**CADMIUM-FREE**

These solders are cadmium-free and are offered in one pennyweight sheets. They are offered in standard karat golds and palladium.

Solder Quality	Melting Point (°F)	Flow Point (°F)	Approximate Price Per Pennyweight (dwt)		
			1 dwt	50 dwt	100 dwt
6K Yellow, Easy	1245° F	1300° F	\$24.92	\$22.84	\$22.49
8K Yellow, Easy	1210° F	1295° F	\$30.77	\$28.68	\$28.34
10K Yellow, Easy	1200° F	1345° F	\$36.36	\$34.28	\$33.93
10K Yellow, Medium	1260° F	1375° F	\$36.36	\$34.28	\$33.93
10K Yellow, Hard	1395° F	1430° F	\$36.36	\$34.28	\$33.93
12K Yellow, Easy	1210° F	1365° F	\$42.18	\$40.10	\$39.75
14K Yellow, Easy	1225° F	1335° F	\$48.02	\$45.94	\$45.59
14K Yellow, Medium	1300° F	1420° F	\$48.02	\$45.94	\$45.59
14K Yellow, Hard	1475° F	1500° F	\$48.02	\$45.94	\$45.59
18K Yellow, Easy	1300° F	1360° F	\$59.79	\$57.71	\$57.36
18K Yellow, Medium	1360° F	1405° F	\$59.79	\$57.71	\$57.36
18K Yellow, Hard	1440° F	1475° F	\$59.79	\$57.71	\$57.36
8K White, Easy	1345° F	1370° F	\$31.27	\$29.18	\$28.84
10K White, Easy	1240° F	1290° F	\$37.17	\$35.08	\$34.74
10K White, Hard	1305° F	1350° F	\$37.17	\$35.08	\$34.74
12K White, Easy	1270° F	1305° F	\$42.83	\$40.75	\$40.40
14K White, Easy	1235° F	1305° F	\$48.62	\$46.54	\$46.19
14K White, Medium	1335° F	1365° F	\$48.62	\$46.54	\$46.19
14K White, Hard	1450° F	1470° F	\$48.62	\$46.54	\$46.19
14K Palladium White, Hard	1370° F	1445° F	\$52.71	\$50.63	\$50.28
18K White, Easy	1330° F	1365° F	\$60.27	\$58.19	\$57.84
18K White, Hard	1490° F	1525° F	\$60.27	\$58.19	\$57.84
18K Palladium White, Hard	1750° F	1775° F	\$65.86	\$63.78	\$63.43
19K White, Weld	1635° F	1670° F	\$62.97	\$60.89	\$60.55
20K White, Weld	1570° F	1600° F	\$66.11	\$64.03	\$63.68
14K Rose, Medium	1564° F	1565° F	\$48.39	\$46.31	\$45.96
14K Rose, Hard	1569° F	1571° F	\$48.39	\$46.31	\$45.96



**GOLD REPAIR SOLDER SHEET**

**CADMIUM-BEARING**

Karat gold repair solders are lower in karat than the work for which they are recommended. Repair solders are easier flowing than our plumb solders and are an economical way to perform various solder tasks. Supplied in one pennyweight sheets.

**WARNING**  
Cadmium-bearing solders contain chemicals known to cause cancer, birth defects, and other health related problems.

Solder Quality	Melting Point (°F)	Flow Point (°F)	Approximate Price Per Pennyweight (dwt)		
			1 dwt	50 dwt	100 dwt
14K Yellow, Easy	1170° F	1230° F	\$36.36	\$34.28	\$33.93
14K Yellow, Hard	1310° F	1360° F	\$36.36	\$34.28	\$33.93
18K White, Easy	1235° F	1275° F	\$60.27	\$58.19	\$57.84

**GOLD REPAIR SHEET**

**CADMIUM-FREE**

Karat gold repair solders flow easier than our plumb solders and are an economical way to perform various soldering tasks. These solders are lower in karat than the work for which they are recommended. Sold in one pennyweight sheets.

Solder Quality (Repair)	Gold Content	Melting Point (°F)	Flow Point (°F)	Approximate Price Per Pennyweight (dwt)		
				1 dwt	50 dwt	100 dwt
14K Yellow, Easy	10K	1200° F	1345° F	\$36.36	\$34.28	\$33.93
14K Yellow, Hard	10K	1395° F	1430° F	\$36.36	\$34.28	\$33.93
14K White, Easy	10K	1240° F	1290° F	\$37.17	\$35.08	\$34.74
14K White, Hard	10K	1305° F	1350° F	\$37.17	\$35.08	\$34.74



LEAD TIMES: 10K Yellow, 14K Yellow, 14K White, 18K Yellow and Sterling Silver will ship same day in most cases. Back orders will ship the following day. All other metal qualities are MTO (made to order) and will ship within three working days in most cases. Same-day shipping subject to order specifications, special request, and inventory on hand at time of order. Additional charges and lead times may apply to odd quantities.



100% Recycled Gold and Silver.  
Visit [Stuller.com/SensibleSourcing](http://Stuller.com/SensibleSourcing) for more information.

**STULLER METALS CLUB**

Call **877-619-2173** to join the Metals Club and start saving today.



**COLOR-MATCH GOLD PLUMB SOLDER SHEET**

**CADMIUM-FREE** This solder is currently used in our day-to-day manufacturing. Our karat gold color match solders provide excellent soldering characteristics as they were formulated to match the color of our karat gold shanks, findings, mountings, and mill products. Each solder quality has been extensively tested in-house for color match, flow, and polishing characteristics.

Solder Quality	Melting Point (°F)	Flow Point (°F)	Approximate Price Per Pennyweight (dwt)		
			1 dwt	50 dwt	100 dwt
14K Yellow, Easy	1270° F	1280° F	\$48.02	\$45.94	\$45.59
14K Yellow, Medium	1375° F	1430° F	\$48.02	\$45.94	\$45.59
14K Yellow, Hard	1450° F	1480° F	\$48.02	\$45.94	\$45.59
18K Yellow, Medium	1345° F	1460° F	\$59.79	\$57.71	\$57.36
10K White, Easy	1255° F	1260° F	\$37.17	\$35.08	\$34.74
14K White, Easy	1305° F	1330° F	\$48.62	\$46.54	\$46.19
14K White, Hard	1445° F	1500° F	\$48.62	\$46.54	\$46.19
14K X1 White, Easy	1300° F	1330° F	\$48.93	\$46.84	\$46.50
14K X1 White, Medium	1350° F	1390° F	\$48.93	\$46.84	\$46.50
18K White, Hard	1475° F	1530° F	\$60.27	\$58.19	\$57.84

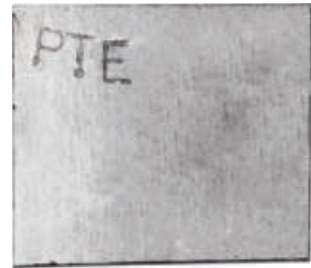

**PLATINUM PLUMB SOLDER SHEET**

**CADMIUM-FREE** Plumb platinum solders provide a superior white color as compared to traditional solders for platinum work. Because of the higher platinum content (90% to 95%), the color is nearly a perfect match with most platinum alloys. Polishing problems are also reduced as the hardness of these solders closely matches the surrounding platinum alloy. \*Supplied in 1/2 dwt sheets.

Solder Quality	Platinum Content	Melting Point (°F)	Flow Point (°F)	Approximate Price Per Pennyweight (dwt)		
				1/2 dwt	1 dwt	50 dwt
Easy, Plumb	90%	2370° F	2470° F	\$36.29	\$77.96	\$75.58
Medium, Plumb	92.5%	2550° F	2650° F	\$36.29	\$77.96	\$75.58
Hard, Plumb	95%	2730° F	2830° F	\$36.29	\$77.96	\$75.58



**PLATINUM REPAIR SOLDER SHEET**

**CADMIUM-FREE** Solders for platinum are supplied in one pennyweight sheets. Prices are approximate and will fluctuate with platinum, palladium, gold, and silver markets.

Solder For Platinum (°C)	Platinum Content	Melting Point (°F)	Flow Point (°F)	Approximate Price Per Pennyweight (dwt)		
				1 dwt	50 dwt	100 dwt
1000° C Extra Easy	5%	1915° F	2015° F	\$39.82	\$38.34	\$38.18
1100° C Easy	0%	2080° F	2180° F	\$47.15	\$45.68	\$45.52
1200° C Medium	3%	2185° F	2285° F	\$59.93	\$58.46	\$58.29
1300° C Hard	0%	2370° F	2470° F	\$74.95	\$73.48	\$73.31
1400° C Extra Hard	5%	2550° F	2650° F	\$71.07	\$69.60	\$69.44
1500° C Weld	0%	2730° F	2830° F	\$71.70	\$70.23	\$70.06
1600° C Special Weld	7.5%	2910° F	3010° F	\$50.39	\$48.91	\$48.75
1700° C Seamless	70%	3090° F	3190° F	\$60.33	\$58.86	\$58.70
1773° C Platinum Weld	100%	3224° F	3320° F	\$71.29	\$69.81	\$69.65



**SILVER SOLDER SHEET**

**CADMIUM-FREE** Silver sheet solder is supplied in one pennyweight vials.

Solder Quality	Silver Content	Melting Point (°F)	Flow Point (°F)	Approximate Price	
				1 dwt	100 dwt
Silver, Easy	60%	1230° F	1285° F	\$2.55	\$2.45
Silver, Medium	70%	1300° F	1335° F	\$2.55	\$2.45
Silver, Hard	80%	1410° F	1420° F	\$2.55	\$2.45

**GOLD PLUMB CHIPPED SOLDER**

**CADMIUM-BEARING**

Gold chipped solder is supplied in one pennyweight vials.

**WARNING**  
Cadmium-bearing solders contain chemicals known to cause cancer, birth defects, and other health related problems.

Solder Quality	Melting Point (°F)	Flow Point (°F)	Approximate Price Per Pennyweight (dwt)		
			1 dwt	50 dwt	100 dwt
10K Yellow, Easy	1180° F	1230° F	\$39.36	\$37.28	\$36.93
14K Yellow, Ultra Easy	1070° F	1165° F	\$51.02	\$48.94	\$48.59
14K Yellow, Easy	1180° F	1320° F	\$51.02	\$48.94	\$48.59
14K Yellow, Hard	1410° F	1460° F	\$51.02	\$48.94	\$48.59
10K White, Easy	1250° F	1290° F	\$40.17	\$38.08	\$37.74
14K White, Easy	1235° F	1270° F	\$51.62	\$49.54	\$49.19
14K White, Hard	1330° F	1380° F	\$51.62	\$49.54	\$49.19
14K Rose, Weld	1600° F	1690° F	\$52.89	\$50.81	\$50.46



**GOLD PLUMB CHIPPED SOLDER**

**CADMIUM-FREE**

Gold chipped solder is supplied in one pennyweight vials.

Solder Quality	Melting Point (°F)	Flow Point (°F)	Approximate Price Per Pennyweight (dwt)		
			1 dwt	50 dwt	100 dwt
10K Yellow, Easy	1200° F	1345° F	\$39.36	\$37.28	\$36.93
10K Yellow, Hard	1395° F	1430° F	\$39.36	\$37.28	\$36.93
14K Yellow, Easy	1225° F	1335° F	\$51.02	\$48.94	\$48.59
14K Yellow, Medium	1300° F	1420° F	\$51.02	\$48.94	\$48.59
14K Yellow, Hard	1475° F	1500° F	\$51.02	\$48.94	\$48.59
14K White, Easy	1235° F	1305° F	\$51.62	\$49.54	\$49.19
14K White, Medium	1335° F	1365° F	\$51.62	\$49.54	\$49.19
14K White, Hard	1450° F	1470° F	\$51.62	\$49.54	\$49.19
18K White, Hard	1490° F	1525° F	\$60.27	\$58.19	\$57.84
19K White, Weld	1635° F	1670° F	\$65.97	\$63.89	\$63.55



**SILVER CHIPPED SOLDER**

**CADMIUM-FREE**

Silver chipped solder is supplied in one pennyweight vials.

Solder Quality	Silver Content	Melting Point (°F)	Flow Point (°F)	Approximate Price	
				1 dwt	100 dwt
Silver, Easy	65%	1230° F	1285° F	\$2.65	\$2.54
Silver, Medium	70%	1230° F	1335° F	\$2.65	\$2.54
Silver, Hard	75%	1410° F	1420° F	\$2.65	\$2.54

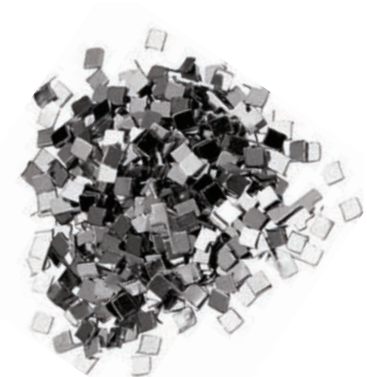

**STULLER METALS CLUB**

Call 877-619-2173 to join the Metals Club and start saving today.





**GOLD PLUMB SOLDER WIRE**  
CADMIUM-BEARING

**WARNING**  
Cadmium-bearing solders contain chemicals known to cause cancer, birth defects, and other health related problems.

Solder Quality	Gauge	Melting Point (°F)	Flow Point (°F)	Approximate Price Per Pennyweight (dwt)		
				1 dwt	50 dwt	100 dwt
14K Yellow, Ultra Easy	24	1070° F	1165° F	\$48.02	\$45.94	\$45.59
14K Yellow, Ultra Easy	30	1070° F	1165° F	\$48.02	\$45.94	\$45.59
14K Yellow, Easy	24	1180° F	1320° F	\$48.02	\$45.94	\$45.59



**SILVER SOLDER WIRE**  
CADMIUM-FREE

Solder Quality	Gauge	Silver Content	Melting Point (°F)	Flow Point (°F)	Approximate Price	
					1 dwt	100 dwt
Silver, Easy	20	56%	1160° F	1285° F	\$1.44	\$1.39
Silver, Medium	20	70%	1300° F	1335° F	\$1.44	\$1.39
Silver, Hard	20	80%	1410° F	1420° F	\$1.44	\$1.39
Silver, Hard	28	80%	1410° F	1420° F	\$1.44	\$1.39
Continuum Sterling Silver, Medium	20	84%	1350° F	1550° F	\$2.78	\$2.74
Continuum Sterling Silver, Hard	20	86%	1470° F	1600° F	\$2.78	\$2.74

Minimum order is 5 feet (approximately 5 pennyweights) per quality.



**SILVER SOLDER STRIP**  
CADMIUM-FREE

Supplied in convenient 12" x .016" strips. Each silver strip weighs approximately five pennyweights. Minimum order is one strip.

Solder Quality	Silver Content	Melting Point (°F)	Flow Point (°F)	Approximate Price	
				1 dwt	100 dwt
Silver, Easy	56%	1230° F	1285° F	\$2.00	\$1.90
Silver, Medium	70%	1300° F	1335° F	\$2.00	\$1.90
Silver, Hard	75%	1410° F	1420° F	\$2.00	\$1.90

**Solder Tip**

When soldering, wear protective goggles with a shade number of at least four to protect against infrared radiation. They should be approved by the American National Standards Institute (ANSI). Full-faced shields are also available to protect the face. Use leather protective gloves to handle hot metals.

**GOLD PASTE SOLDER**

**CADMIUM-FREE**

Our paste solder is packaged in a syringe that contains one pennyweight of gold solder and flux. This paste is excellent for chain repair and fine detail work due to the special formula that leaves little or no carbon residue, providing clean, bright assemblies. It is compatible with our paste solder hand applicator.

Solder Quality	Solder Type	Melting Point (°F)	Flow Point (°F)	Approximate Price Per Pennyweight (dwt)		
				1 dwt	20 dwt	50 dwt
1K Yellow Gold-Filled	Plumb	1135° F	1170° F	\$9.85	\$8.12	\$7.77
6K Yellow	Repair	1110° F	1295° F	\$24.92	\$23.18	\$22.84
10K Yellow Easy	Plumb	1195° F	1290° F	\$36.36	\$34.63	\$34.28
10K Yellow Medium	Plumb	1293° F	1375° F	\$36.36	\$34.63	\$34.28
10K Yellow Hard	Plumb	1395° F	1450° F	\$36.36	\$34.63	\$34.28
14K Yellow Easy	Plumb	1185° F	1330° F	\$48.02	\$46.29	\$45.94
14K Yellow Medium	Plumb	1330° F	1390° F	\$48.02	\$46.29	\$45.94
14K Yellow Hard	Plumb	1400° F	1440° F	\$48.02	\$46.29	\$45.94
18K Yellow Easy	Plumb	1270° F	1320° F	\$59.79	\$58.05	\$57.71
6K White	Repair	1120° F	1315° F	\$25.04	\$23.30	\$22.96
10K White Easy	Plumb	1130° F	1260° F	\$36.67	\$34.93	\$34.58
10K White Medium	Plumb	1200° F	1320° F	\$36.67	\$34.93	\$34.58
10K White Hard	Plumb	1340° F	1450° F	\$36.67	\$34.93	\$34.58
14K White Easy	Plumb	1160° F	1280° F	\$48.02	\$46.29	\$45.94
14K White Medium	Plumb	1325° F	1405° F	\$48.02	\$46.29	\$45.94
14K White Hard	Plumb	1335° F	1445° F	\$48.02	\$46.29	\$45.94
14K X1® White Ultra Easy	Plumb	1040° F	1280° F	\$48.43	\$46.69	\$46.34

**SILVER PASTE SOLDER**

**CADMIUM-FREE**

Silver paste solder is powdered and mixed with the proper proportion of flux, and packaged in convenient, disposable syringes. Specially formulated binders assure that little or no carbon residue is left on the joint when soldering. Each syringe contains three pennyweights of silver solder and flux, and is designed to work in our new paste solder hand applicator.

Solder Quality	Silver Content	Melting Point (°F)	Flow Point (°F)	Approximate Per Syringe
				3 dwt
Silver, Extra Easy	56%	1140° F	1205° F	\$5.11
Silver, Easy	65%	1240° F	1325° F	\$5.11
Silver, Medium	70%	1275° F	1360° F	\$5.11
Silver, Hard	75%	1365° F	1450° F	\$5.11



**MK3 PASTE SOLDER DISPENSER**

Manual solder dispenser designed to deposit paste solders with pinpoint accuracy. Use with Stuller paste solders syringes.

Order #	Description	12+	6+	1+
54-4010	MK3 Solder Dispenser	\$24.01	\$25.43	\$28.25



Paste sold separately



100% Recycled Gold and Silver.  
Visit [Stuller.com/SensibleSourcing](https://www.stuller.com/SensibleSourcing) for more information.

**STULLER METALS CLUB** | Call **877-619-2173** to join the Metals Club and start saving today.



**ROUND**

**Order # 30000**

mm OD	4.76	6.35	7.94	8.73	9.53	11.11	12.7	13.49	14.29	15.88
Inches (OD)	3/16"	1/4"	5/16"	1/2"	3/8"	7/16"	1/2"	17/32"	9/16"	5/8"
Pennyweights (dwt)	0.12	0.21	0.33	0.40	0.48	0.65	0.85	0.96	1.05	1.35
14K Yellow	\$6.77	\$12.56	\$18.46	\$22.38	\$26.86	\$36.46	\$47.59	\$53.58	\$58.63	\$75.61

mm OD	17.46	19.05	20.64	22.23	23.81	25.4	26.99	28.58	30.16	31.75
Inches (OD)	11/16"	3/4"	13/16"	7/8"	15/16"	1"	1 1/16"	1 1/8"	1 1/16"	1 1/4"
Pennyweights (dwt)	1.59	1.91	2.29	2.64	3.01	3.47	3.89	4.35	4.85	5.32
14K Yellow	\$88.83	\$106.89	\$128.27	\$147.46	\$168.40	\$194.25	\$217.50	\$243.46	\$271.11	\$297.60

mm OD	33.34	34.93	38.1	41.28	44.45	47.63	50.8	57.15	63.5
Inches (OD)	1 1/16"	1 3/8"	1 1/2"	1 5/8"	1 3/4"	1 7/8"	2"	2 1/4"	2 1/2"
Pennyweights (dwt)	5.74	6.24	7.66	9.10	10.23	11.84	13.58	17.17	21.20
14K Yellow	\$321.14	\$349.12	\$428.43	\$509.05	\$572.35	\$662.42	\$759.91	\$960.74	\$1,186.10



**ROUND, UNDRILLED EYELET**

**Order # 30000**

mm OD	8	9.5	11	13.5	14.25	16	17.5	19	20.75	22.25
Pennyweights (dwt)	0.35	0.53	0.67	0.98	1.15	1.42	1.65	2.09	2.50	2.64
14K Yellow	\$19.58	\$29.89	\$37.51	\$54.71	\$64.18	\$79.51	\$92.44	\$116.70	\$139.78	\$147.83

mm OD	23.75	25.25	26	27.25	30	41.25	44.25
Pennyweights (dwt)	3.08	3.41	3.60	3.89	4.97	9.06	10.38
14K Yellow	\$172.32	\$190.69	\$201.49	\$217.75	\$278.06	\$507.00	\$580.74



**LONG OVAL**

**Order # 30005**

mm OD	11x5	12.5x6.75	19x7.75	20.5x10.75	24.5x12.75	26x9.5	42x20
Pennyweights (dwt)	0.28	0.45	0.77	1.19	1.68	1.32	4.31
14K Yellow	\$15.46	\$25.20	\$43.22	\$66.81	\$93.99	\$73.85	\$240.90

**OVAL**

**Order # 30005**

mm OD	8.25x6.75	11x9	12.75x11.25	13.5x9.25	17.25x12.75	18.25x11.25	18.25x13.75
Pennyweights (dwt)	0.30	0.51	0.77	0.68	1.14	1.12	1.36
14K Yellow	\$16.78	\$28.73	\$43.08	\$38.04	\$63.50	\$62.51	\$76.16

mm OD	18.75x15.5	19x12.25	22x15.25	26.5x19.5	31.75x25.5	37x31	38.25x29
Pennyweights (dwt)	1.51	1.22	1.74	2.77	4.30	6.11	5.87
14K Yellow	\$84.67	\$68.42	\$97.19	\$155.09	\$240.72	\$342.07	\$328.64

**OVAL, SMALL UNDRILLED EYELET**

**Order # 30005**

mm OD	19.75x16.25	26x16	28.25x21.25	32x25.5
Pennyweights (dwt)	1.78	2.27	3.19	4.37
14K Yellow	\$99.82	\$127.24	\$178.34	\$244.55

**OVAL, LARGE UNDRILLED EYELET**

**Order # 30012**

mm OD	28.5x21	31.75x23
Pennyweights (dwt)	3.33	3.98
14K Yellow	\$186.52	\$222.48



**SQUARE**

**Order # 30006**

mm OD	9.75x9.75	12.75x12.75	14x14	16.25x16.25
Pennyweights (dwt)	0.63	1.10	1.32	1.68
14K Yellow	\$35.43	\$61.68	\$73.57	\$93.99

mm OD	17x17	19.25x19.25	22.25x22.25	28.75x28.75
Pennyweights (dwt)	1.97	2.49	3.31	5.41
14K Yellow	\$110.13	\$139.09	\$185.09	\$302.54

**SQUARE, UNDRILLED EYELET**

**Order # 30006**

mm OD	17.5x17.5	22.5x22.25	28.75x28.75
Pennyweights (dwt)	2.08	3.43	5.66
14K Yellow	\$116.37	\$191.62	\$316.39



100% Recycled Gold and Silver.  
Visit [Stuller.com/SensibleSourcing](http://Stuller.com/SensibleSourcing)  
for more information.

**Note:** Stampings are also available in sterling silver. Special orders requesting sterling silver require a minimum order quantity and additional lead times.

Prices for stampings are based on 20 gauge.

All prices are priced at jeweler's cost based on \$1,400 gold, \$1,150 platinum, \$750 palladium, and \$20 silver and are subject to change without notice. Visit [Stuller.com](http://Stuller.com) for our complete product selections, current pricing, and quantity price breaks. | 385

**STULLER METALS CLUB** | Call **877-619-2173** to join the Metals Club and start saving today.





**LONG RECTANGLE**

**Order # 30003**

mm OD	8.5×5.5	13×11	17×11.75	19.25×12.75	19.25×16.25
Pennyweights (dwt)	0.31	0.96	1.32	1.62	1.98
14K Yellow	\$17.34	\$53.60	\$74.05	\$90.71	\$110.92

mm OD	20.75×16.75	22.5×18.5	25.5×22.25	28.75×23.25	32.75×27
Pennyweights (dwt)	2.34	2.78	3.73	4.52	5.86
14K Yellow	\$130.92	\$155.44	\$208.83	\$252.66	\$327.92

**LONG RECTANGLE, UNDRILLED EYELET**

**Order # 30003**

mm OD	13.75×6.5	19.25×16.25	22.25×9.5	27×22.25
Pennyweights (dwt)	0.62	2.17	1.52	4.13
14K Yellow	\$34.59	\$121.31	\$84.91	\$231.30

**RECTANGLE, ROUND EDGE & UNDRILLED EYELET**

**Order # 30009**

mm OD	20.5×16.25	21.5×14.25	37.5×28.25
Pennyweights (dwt)	2.25	2.19	7.20
14K Yellow	\$126.11	\$122.30	\$402.69

**RECTANGLE, UNDRILLED EYELET**

**Order # 30010**

mm OD	14.25×19	17.5×22	19.25×22.5	19.5×25.5	21×27
Pennyweights (dwt)	1.84	2.64	2.95	3.40	3.90
14K Yellow	\$102.94	\$147.59	\$164.80	\$190.38	\$218.06

mm OD	22.25×25.5	24×32	26.25×32	29.75×32.5
Pennyweights (dwt)	3.79	5.23	5.6433	6.585
14K Yellow	\$212.04	\$292.61	\$315.73	\$368.42

**LONG RECTANGLE, ROUND EDGE**

**Order # 30009**

mm OD	18.25×13.5	22.25×18	22.25×19.5	22.5×11.25
Pennyweights (dwt)	1.59	2.67	2.85	1.68
14K Yellow	\$89.05	\$149.33	\$159.31	\$93.88

**DIAMOND-SHAPE UNDRILLED EYELET**

**Order # 30001**

mm OD	13×13	14×14	16×16	17×17	19×19	25.5×25.5	28×28
Pennyweights (dwt)	1.1533	1.3233	1.755	2.035	2.4827	4.3137	5.54
14K Yellow	\$64.52	\$74.04	\$98.19	\$113.85	\$138.90	\$241.34	\$309.95



100% Recycled Gold and Silver.  
Visit [Stuller.com/SensibleSourcing](http://Stuller.com/SensibleSourcing)  
for more information.

**Note:** Stampings are also available in sterling silver. Special orders requesting sterling silver require a minimum order quantity and additional lead times.

Prices for stampings are based on 20 gauge.

**OCTAGON**

**Order # 30004**

mm OD	20.25×20.25	31.75×31.75
Pennyweights (dwt)	2.24	5.56
14K Yellow	\$125.04	\$310.79

**OCTAGON, UNDRILLED EYELET**

**Order # 30004**

mm OD	20×20	24.25×24.5	27×27	31.75×32
Pennyweights (dwt)	2.31	3.32	4.09	5.48
14K Yellow	\$129.46	\$185.84	\$228.97	\$306.71

**LONG OCTAGON**

**Order # 30011**

mm OD	14.25×12.25	15.5×12	16.5×15
Pennyweights (dwt)	1.06	1.10	1.47
14K Yellow	\$59.21	\$61.54	\$82.15

**LONG OCTAGON UNDRILLED EYELET**

**Order # 30011**

mm OD	27.5×27.5	32×31.75	36×26.5
Pennyweights (dwt)	4.64	6.05	6.05
14K Yellow	\$338.49	\$259.36	\$303.74

**TEARDROP**

**Order # 30007**

mm OD	11.5×8	14×8.5	17.75×11.25	19×13	32.75×21.5	36.25×24.75
Pennyweights (dwt)	0.42	0.50	0.93	1.18	3.30	4.37
14K Yellow	\$23.61	\$27.89	\$52.03	\$65.93	\$184.40	\$244.63



**STULLER  
METALS CLUB**

Call **877-619-2173** to join the  
Metals Club and start saving today.

All prices are priced at jeweler's cost based on \$1,400 gold, \$1,150 platinum, \$750 palladium, and \$20 silver and are subject to change without notice.  
Visit [Stuller.com](http://Stuller.com) for our complete product selections, current pricing, and quantity price breaks. | 387

**TRIANGLE**

**Order # 30008**



mm OD	20.75x24	27.5x25.5	33x38
Pennyweights (dwt)	2.14	2.41	4.13
14K Yellow	\$119.67	\$134.62	\$231.07

**HEART**

**Order # 30002**



mm OD	5x5	6.5x6.75	8x8	10x10	13x12
Pennyweights (dwt)	0.11	0.21	0.34	0.46	0.75
14K Yellow	\$6.18	\$11.75	\$18.93	\$25.87	\$42.11

mm OD	17x15	20x19.25	24.5x24.5	31x31	39.5x39.25
Pennyweights (dwt)	1.15	1.77	2.93	4.50	7.77
14K Yellow	\$64.49	\$99.11	\$163.93	\$251.95	\$434.44

**HEART, UNDRILLED EYELET**

**Order # 30002**



mm OD	6.75x6.75*	7.5x5.5	10x9.25	12.75x13.25
Pennyweights (dwt)	0.09	0.20	0.42	0.85
14K Yellow	\$5.04	\$10.97	\$23.50	\$47.53

\* Available in 30 gauge only.

mm OD	18.25x18.75	20x19.25	21.5x20.5	26x24.25
Pennyweights (dwt)	1.73	1.86	2.18	3.13
14K Yellow	\$96.62	\$104.10	\$121.97	\$175.07

mm OD	30.75x31	33.75x31	36.75x36	40x39.5
Pennyweights (dwt)	4.54	5.22	6.53	7.62
14K Yellow	\$254.16	\$291.86	\$365.06	\$426.46



<b>3398</b> 7.25x17.5mm 0.76 dwt 14K Yellow, \$42.24	<b>3133</b> 8x23mm 0.93 dwt 14K Yellow, \$52.03	<b>3297</b> 6.25x19.25mm 0.24 dwt 14K Yellow, \$13.43 Available in 30 gauge only.	<b>3390</b> 5.25x24.5mm 0.89 dwt 14K Yellow, \$49.88	<b>3397</b> 5.25x33mm 1.22 dwt 14K Yellow, \$68.09	<b>3396</b> 7x39mm 1.88 dwt 14K Yellow, \$104.95
---	--	---	---	---	---



<b>3800</b> 4.25x16.25mm 0.25 dwt 14K Yellow, \$13.99 Available in 22 gauge only.	<b>3801</b> 6.25x12.5mm .4757 dwt 14K Yellow, \$26.61	<b>3892</b> 10.25x20.5mm 0.46 dwt 14K Yellow, \$25.74 Available in 26 gauge only.	<b>3891</b> 8.25x23.75mm 0.435 dwt 14K Yellow, \$24.34 Available in 26 gauge only.	<b>3296</b> 9.25x20.25mm 0.2895 dwt 14K Yellow, \$16.20 Available in 30 gauge only.	<b>3393</b> 9x20.5mm 0.835 dwt 14K Yellow, \$46.72
---	--	---	--	---	---



<b>3807</b> 22.75x17.75mm 1.7613 dwt 14K Yellow, \$98.54	<b>3732</b> 14.5x12.5mm 0.95 dwt 14K Yellow, \$53.34	<b>3733</b> 15.25x14mm 1.05 dwt 14K Yellow, \$58.70	<b>3736</b> 21.75x19.25mm 2.05 dwt 14K Yellow, \$114.89	<b>3737</b> 22.5x20mm 2.33 dwt 14K Yellow, \$130.19
---	---	--	--	--



<b>3731</b> 18.25x14.75mm 1.4943 dwt 14K Yellow, \$83.60	<b>3730</b> 22.75x18.75mm 2.2285 dwt 14K Yellow, \$124.68	<b>3160</b> 30x20mm 2.8384 dwt 14K Yellow, \$158.80	<b>3806</b> 22.25x15.5mm 1.6226 dwt 14K Yellow, \$90.78 Available in 19 gauge only.	<b>3735</b> 15.5x14mm 1.3597 dwt 14K Yellow, \$76.07 Available in 18 gauge only.
---	--	--	---	--



<b>3787</b> 14x12.5mm 0.95 dwt 14K Yellow, \$53.01	<b>3161</b> 31x20.5mm 2.61 dwt 14K Yellow, \$146.05	<b>3734</b> 18.75x17.5mm 1.54 dwt 14K Yellow, \$86.19	<b>3742</b> 21x17.75mm 1.98 dwt 14K Yellow, \$110.81	<b>3739</b> 21.25x19.25mm 2.22 dwt 14K Yellow, \$124.04
---	--	--	---	--



<b>3738</b> 21.5x21mm 2.457 dwt 14K Yellow, \$137.46 Available in 18 gauge only.	<b>3710</b> 24.25x11.25mm 1.32 dwt 14K Yellow, \$73.85 Available in 18 gauge only.	<b>3709</b> 24.5x13.75mm 1.5428 dwt 14K Yellow, \$86.32	<b>3713</b> 18.25x15.25mm 1.2061 dwt 14K Yellow, \$67.48 Available in 16 gauge only.	<b>3656</b> 22.75x20.75mm 2.3642 dwt 14K Yellow, \$132.27 Available in 18 gauge only.
--	--	--	--	---



Metals

Metals



**3291**  
32.25mm  
5.10 dwt  
14K Yellow, \$285.22



**3385**  
21.25mm  
2.38 dwt  
14K Yellow, \$133.31



**3382**  
21.5mm  
2.40 dwt  
14K Yellow, \$134.21



**3251**  
24x19mm  
2.32 dwt  
14K Yellow, \$129.73



**3252**  
29x23.5mm  
3.50 dwt  
14K Yellow, \$195.82



**3137**  
12x7.5mm  
0.19 dwt  
14K Yellow, \$10.63



**3719**  
11.5x8mm  
0.21 dwt  
14K Yellow, \$11.93



**3146**  
18x13mm  
0.57 dwt  
14K Yellow, \$31.64



**3136**  
22x13mm  
0.51 dwt  
14K Yellow, \$28.33



**3145**  
25.5x15.5mm  
0.76 dwt  
14K Yellow, \$42.41



**3267**  
32x24.5mm  
3.95 dwt  
14K Yellow, \$220.99



**3365**  
37.25x30.75mm  
5.69 dwt  
14K Yellow, \$318.59



**3383**  
19.25mm  
1.75 dwt  
14K Yellow, \$98.14



**3384**  
26.25mm  
3.61 dwt  
14K Yellow, \$201.97



**3287**  
25.25mm  
3.33 dwt  
14K Yellow, \$186.31



**3135**  
30x18mm  
0.93 dwt  
14K Yellow, \$52.17



**3723**  
7x6.5mm  
0.15 dwt  
14K Yellow, \$8.54



**3727**  
14x14mm  
0.45 dwt  
14K Yellow, \$25.00



**3722**  
18x17.75mm  
1.27 dwt  
14K Yellow, \$71.05  
Available in 18 gauge only.



**3721**  
21.75x21.75mm  
1.80 dwt  
14K Yellow, \$100.54



**3482**  
26.25x19.5mm  
2.85 dwt  
14K Yellow, \$159.55



**3387**  
22.75x19.25mm  
1.74 dwt  
14K Yellow, \$97.46



**3399**  
22.75x14.25mm  
1.19 dwt  
14K Yellow, \$66.77



**3539**  
21.75x24.75mm  
2.81 dwt  
14K Yellow, \$157.31



**3756**  
22.5x14.75mm  
1.12 dwt  
14K Yellow, \$62.85



**3725**  
12.25x5.75mm  
0.21 dwt  
14K Yellow, \$11.75



**3726**  
25.75x11mm  
0.60 dwt  
14K Yellow, \$33.43



**3300**  
9.75x9.25mm  
0.28 dwt  
14K Yellow, \$15.39



**3744**  
6.25x6.5mm  
0.10 dwt  
14K Yellow, \$5.59



**3745**  
6.5x6.75mm  
0.13 dwt  
14K Yellow, \$7.27



**3420**  
23.5x18.5mm  
1.15 dwt  
14K Yellow, \$64.18



**3419**  
22.7mm  
1.84 dwt  
14K Yellow, \$102.83



**3253**  
24.5x19.5mm  
1.62 dwt  
14K Yellow, \$90.86



**3372**  
37.5x31.25mm  
3.49 dwt  
14K Yellow, \$195.19



**3544**  
26.5x20mm  
2.76 dwt  
14K Yellow, \$154.42



**3743**  
10x10.25mm  
0.27 dwt  
14K Yellow, \$15.11



**3747**  
18.25x19mm  
0.88 dwt  
14K Yellow, \$48.98



**3157**  
40.5x35.5mm  
2.81 dwt  
14K Yellow, \$157.29



**3360**  
13.75x9.75mm  
0.51 dwt  
14K Yellow, \$28.53



**3361**  
10.5x5.5mm  
0.12 dwt  
14K Yellow, \$6.71



**3359**  
10x5.25mm  
0.15 dwt  
14K Yellow, \$8.39



**3818**  
11.25x7mm  
0.16 dwt  
14K Yellow, \$8.95



**3771**  
15.75x13.25mm  
0.56 dwt  
14K Yellow, \$31.55



**3770**  
20.25x16.75mm  
0.70 dwt  
14K Yellow, \$39.16



**3362**  
28x23mm  
1.59 dwt  
14K Yellow, \$88.96



**3338**  
22.25x22mm  
2.25 dwt  
14K Yellow, \$125.69



**3809**  
19.25x17.25mm  
1.28 dwt  
14K Yellow, \$71.53  
Available in 18 gauge only.



**3810**  
20x17mm  
1.04 dwt  
14K Yellow, \$58.26  
Available in 18 gauge only.



**3826**  
19.75x18.75mm  
2.44 dwt  
14K Yellow, \$136.51  
Available in 16 gauge only.



**3821**  
21.25x18.5mm  
1.97 dwt  
14K Yellow, \$110.11



**3649**  
19.75x13.25mm  
0.76 dwt  
14K Yellow, \$42.76



**3199**  
7.5x7.5mm  
0.45 dwt  
14K Yellow, \$25.18  
Available in 14 gauge only.



**3331**  
8x18mm  
0.74 dwt  
14K Yellow, \$41.28



**3804**  
13.5x17.5mm  
0.93 dwt  
14K Yellow, \$52.03



**3306**  
11x9.75mm  
0.60 dwt  
14K Yellow, \$33.38



**3802**  
8x18mm  
0.71 dwt  
14K Yellow, \$39.72



**3887**  
23x20.25mm  
0.51 dwt  
14K Yellow, \$28.53  
Available in 26 gauge only.



**3890**  
22.5x19.5mm  
0.72 dwt  
14K Yellow, \$40.00  
Available in 26 gauge only.



**3761**  
10x5.75mm  
0.13 dwt  
14K Yellow, \$6.99



**3596**  
6.5x5.5mm  
0.12 dwt  
14K Yellow, \$6.71



**3312**  
17.75x18.5mm  
1.43 dwt  
14K Yellow, \$80.01



**3336**  
18.25x18.75mm  
1.80 dwt  
14K Yellow, \$100.55



**3329**  
16.5x12.5mm  
0.89 dwt  
14K Yellow, \$50.02



**3320**  
17x11mm  
0.86 dwt  
14K Yellow, \$48.18



**3311**  
18.75x18mm  
0.74 dwt  
14K Yellow, \$41.36



**3595**  
8x8  
0.28 dwt  
14K Yellow, \$15.67



**3594**  
11.75x12.25  
0.68 dwt  
14K Yellow, \$38.21  
Available in 18 gauge only.



**3592**  
19.25x19  
0.77 dwt  
14K Yellow, \$42.80



**3586**  
22.5x24  
1.43 dwt  
14K Yellow, \$80.01



**3587**  
33.25x31  
2.44 dwt  
14K Yellow, \$136.32



**3318**  
21.75x20.5mm  
1.03 dwt  
14K Yellow, \$57.55



**3317**  
21x19.5mm  
1.40 dwt  
14K Yellow, \$78.23



**3779**  
22x22mm  
0.98 dwt  
14K Yellow, \$54.55



**3310**  
25x24mm  
2.82 dwt  
14K Yellow, \$157.91



**3309**  
28.5x27.5mm  
3.72 dwt  
14K Yellow, \$208.17



**3829**  
24.25x21.25  
1.98 dwt  
14K Yellow, \$110.78



**3655**  
18.5x9.25  
0.86 dwt  
14K Yellow, \$48.34  
Available in 18 gauge only.



**3651**  
22.25x13.75  
1.11 dwt  
14K Yellow, \$62.20  
Available in 18 gauge only.



**3823**  
23.25x17.75  
1.81 dwt  
14K Yellow, \$101.27



**3865**  
23.5x21  
1.3 dwt  
14K Yellow, \$72.53





**3851**  
18.25×16.5mm  
1.58 dwt  
14K Yellow, \$88.40  
Available in 17 gauge only.



**3897**  
15.5×16mm  
1.06 dwt  
14K Yellow, \$59.30



**3618**  
11.25×13.25mm  
0.76 dwt  
14K Yellow, \$42.41



**3556**  
13×11.25mm  
0.66 dwt  
14K Yellow, \$36.93



**3269**  
12.25×12.5mm  
0.69 dwt  
14K Yellow, \$38.51



**3702**  
16.25×20.75mm  
1.30 dwt  
14K Yellow, \$72.57  
Available in 14 gauge only.



**3700**  
16.25×18.75mm  
1.47 dwt  
14K Yellow, \$82.47  
Available in 16 gauge only.



**3838**  
8×16mm  
0.73 dwt  
14K Yellow, \$40.84  
Available in 16 gauge only.



**3805**  
10.75×17.5mm  
0.64 dwt  
14K Yellow, \$35.90  
Available in 18 gauge only.



**3855**  
14.75×18.75mm  
1.13 dwt  
14K Yellow, \$63.05  
Available in 16 gauge only.



**3560**  
22×17mm  
1.48 dwt  
14K Yellow, \$82.68



**3201**  
9.25×9mm  
0.47 dwt  
14K Yellow, \$26.36



**3803**  
10.75mm  
0.17 dwt  
14K Yellow, \$9.51  
Available in 30 gauge only.



**3849**  
16×19.5mm  
0.53 dwt  
14K Yellow, \$29.65  
Available in 26 gauge only.



**3220**  
13.25×7.75mm  
0.08 dwt  
14K Yellow, \$4.62  
Available in 30 gauge only.



**3870**  
9.5×17.75mm  
0.56 dwt  
14K Yellow, \$31.05



**3853**  
16.25×18.75mm  
0.91 dwt  
14K Yellow, \$51.10  
Available in 14 gauge only.



**3861**  
12.75×9.75mm  
0.43 dwt  
14K Yellow, \$24.06  
Available in 16 gauge only.



**3652**  
14.5×14mm  
0.92 dwt  
14K Yellow, \$51.34



**3898**  
32.75×12.25mm  
0.78 dwt  
14K Yellow, \$43.56



**3232**  
6.5×8.5mm  
0.05 dwt  
14K Yellow, \$2.80  
Available in 30 gauge only.



**3822**  
12.75×5mm  
0.19 dwt  
14K Yellow, \$10.63  
Available in 22 gauge only.



**3230**  
10×7mm  
0.29 dwt  
14K Yellow, \$16.43



**3237**  
10.5×6.5mm  
0.11 dwt  
14K Yellow, \$6.15  
Available in 26 gauge only.



**3819**  
22.5×8.5mm  
0.45 dwt  
14K Yellow, \$25.18



**3842**  
13.5×19.25mm  
2.06 dwt  
14K Yellow, \$115.00  
Available in 16 gauge only.



**3817**  
14.75×12.25mm  
0.79 dwt  
14K Yellow, \$43.98



**3812**  
14.75×17mm  
0.72 dwt  
14K Yellow, \$40.54



**3631**  
23.75×32mm  
2.24 dwt  
14K Yellow, \$125.21



**3757**  
18×16.5mm  
2.10 dwt  
14K Yellow, \$117.59  
Available in 14 gauge only.



**3229**  
21.5×10mm  
0.96 dwt  
14K Yellow, \$53.58  
Available in 26 gauge only.



**3706**  
7.75×7.5mm  
0.18 dwt  
14K Yellow, \$10.07



**3875**  
8.75×8.75mm  
0.29 dwt  
14K Yellow, \$16.31  
Available in 22 gauge only.



**3697**  
10×12.75mm  
0.86 dwt  
14K Yellow, \$48.31  
Available in 16 gauge only.



**3705**  
18×17mm  
1.23 dwt  
14K Yellow, \$68.69  
Available in 14 gauge only.



**3758**  
22×16.5mm  
1.11 dwt  
14K Yellow, \$62.06  
Available in 18 gauge only.



**3608**  
17.5×12mm  
0.72 dwt  
14K Yellow, \$40.28



**3621**  
8×7.25mm  
0.20 dwt  
14K Yellow, \$10.97



**3213**  
8.25×13.5mm  
0.34 dwt  
14K Yellow, \$18.74



**3643**  
13×2.5mm  
0.08 dwt  
14K Yellow, \$4.48

				
<b>3598</b> 6mm 0.17 dwt 14K Yellow, \$9.51	<b>3879</b> 12.5×9mm 0.24 dwt 14K Yellow, \$13.43 Available in 26 gauge only.	<b>3888</b> 18×9.25mm 0.29 dwt 14K Yellow, \$16.22 Available in 26 gauge only.	<b>3889</b> 17.5×9.25mm 0.29 dwt 14K Yellow, \$16.22 Available in 26 gauge only.	<b>3877</b> 17.5×11mm 0.47 dwt 14K Yellow, \$26.02 Available in 26 gauge only.





				
<b>3279</b> 9×6.75mm 0.26 dwt 14K Yellow, \$14.62	<b>3168</b> 13×5.5mm 0.35 dwt 14K Yellow, \$19.72	<b>3542</b> 11.75×11.75mm 0.83 dwt 14K Yellow, \$46.57	<b>3178</b> 12.5×13mm 1.04 dwt 14K Yellow, \$58.09	<b>3543</b> 19.5×16.25mm 1.84 dwt 14K Yellow, \$103.08

				
<b>3850</b> 18.5×12.25mm 1.14 dwt 14K Yellow, \$63.78	<b>3878</b> 17.5×11mm 0.68 dwt 14K Yellow, \$38.04 Available in 22 gauge only.	<b>3894</b> 18×11.25mm 0.55 dwt 14K Yellow, \$30.77 Available in 26 gauge only.	<b>3893</b> 17.75×11.25mm 0.56 dwt 14K Yellow, \$31.11 Available in 26 gauge only.	<b>3620</b> 8.75×9.5mm 0.41 dwt 14K Yellow, \$23.03

				
<b>3541</b> 15×11mm 0.94 dwt 14K Yellow, \$52.52	<b>3536</b> 19×12.75mm 1.53 dwt 14K Yellow, \$85.64	<b>3540</b> 17.5×16mm 1.71 dwt 14K Yellow, \$95.60	<b>3258</b> 16.5×6.75mm 0.70 dwt 14K Yellow, \$39.04	<b>3773</b> 20.25×15mm 1.53 dwt 14K Yellow, \$85.85

				
<b>3883</b> 13.5×13.25mm 0.48 dwt 14K Yellow, \$26.93 Available in 26 gauge only.	<b>3884</b> 13.25mm 0.49 dwt 14K Yellow, \$27.22 Available in 26 gauge only.	<b>3886</b> 16×15.75mm 0.68 dwt 14K Yellow, \$38.04 Available in 26 gauge only.	<b>3885</b> 15.75mm 0.67 dwt 14K Yellow, \$37.29 Available in 26 gauge only.	<b>3881</b> 14×12mm 0.54 dwt 14K Yellow, \$30.21 Available in 26 gauge only.

				
<b>3669</b> 20.25×24.25mm 2.31 dwt 14K Yellow, \$129.24	<b>3683</b> 26.5×20mm 2.88 dwt 14K Yellow, \$160.94	<b>3224</b> 4.75mm 0.12 dwt 14K Yellow, \$6.71	<b>3282</b> 7.5mm 0.40 dwt 14K Yellow, \$22.38	<b>3283</b> 9.25mm 0.45 dwt 14K Yellow, \$25.12

				
<b>3882</b> 14×12mm 0.53 dwt 14K Yellow, \$29.84 Available in 26 gauge only.	<b>3814</b> 17.75×6.5mm 0.34 dwt 14K Yellow, \$19.21 Available in 22 gauge only.	<b>3192</b> 10×15.5mm 0.29 dwt 14K Yellow, \$16.22	<b>3597</b> 6.25×10mm 0.21 dwt 14K Yellow, \$11.75	<b>3606</b> 16.25×3.5mm 0.24 dwt 14K Yellow, \$13.43

				
<b>3286</b> 12.25mm 0.82 dwt 14K Yellow, \$45.88	<b>3210</b> 12.5mm 0.51 dwt 14K Yellow, \$28.42	<b>3364</b> 14.5×12.5mm 0.92 dwt 14K Yellow, \$51.41	<b>3363</b> 19.5×15.25mm 1.53 dwt 14K Yellow, \$85.39	<b>3400</b> 39.5×18.5mm 4.22 dwt 14K Yellow, \$236.10





**3638**  
22.25×14.5mm  
1.39 dwt  
14K Yellow, \$77.83



**3637**  
22.5×14.25mm  
1.41 dwt  
14K Yellow, \$78.89



**3824**  
22.5×19.75mm  
2.06 dwt  
14K Yellow, \$115.33



**3830**  
22.75×19.25mm  
2.02 dwt  
14K Yellow, \$112.74



**3832**  
22.75×19.25mm  
2.01 dwt  
14K Yellow, \$112.52



**3607**  
17×3.75mm  
0.20 dwt  
14K Yellow, \$11.19



**3169**  
18×3.5mm  
0.33 dwt  
14K Yellow, \$18.24



**3600**  
19×5.25mm  
0.24 dwt  
14K Yellow, \$13.43



**3667**  
15×8.25mm  
0.27 dwt  
14K Yellow, \$15.11



**3602**  
37.25×11.5mm  
0.58 dwt  
14K Yellow, \$32.69



**3831**  
22.75×19.25mm  
2.00 dwt  
14K Yellow, \$112.16



**3862**  
28.5×25.5mm  
3.38 dwt  
14K Yellow, \$189.04



**3660**  
27.5×22mm  
0.48 dwt  
14K Yellow, \$27.11  
Available in 30 gauge only.



**3353**  
12.75×11mm  
0.25 dwt  
14K Yellow, \$13.99



**3257**  
14.5×9.75mm  
0.50 dwt  
14K Yellow, \$27.75



**3170**  
11.5×4mm  
0.22 dwt  
14K Yellow, \$12.45



**3837**  
20.75×2.75mm  
0.20 dwt  
14K Yellow, \$11.21



**3215**  
15.75×5.5mm  
0.30 dwt  
14K Yellow, \$16.78



**3880**  
13×9mm  
0.25 dwt  
14K Yellow, \$13.71  
Available in 26 gauge only.



**3134**  
12×22mm  
1.36 dwt  
14K Yellow, \$76.01



**3813**  
15.25×12.5mm  
0.58 dwt  
14K Yellow, \$32.57  
Available in 22 gauge only.



**3261**  
4.75mm  
0.05 dwt  
14K Yellow, \$2.80  
Available in 30 gauge only.



**3218**  
8.5×3.75mm  
0.21 dwt  
14K Yellow, \$11.65



**3663**  
6×4.5mm  
0.11 dwt  
14K Yellow, \$6.15



**3184**  
6×6mm  
0.14 dwt  
14K Yellow, \$7.69



**3295**  
7.25×36.25mm  
1.27 dwt  
14K Yellow, \$71.13



**3391**  
6.75×39mm  
1.44 dwt  
14K Yellow, \$80.77



**3401**  
5.25mm  
0.06 dwt  
14K Yellow, \$3.36  
Available in 30 gauge only.



**3183**  
12mm  
0.75 dwt  
14K Yellow, \$41.77



**3166**  
6.5mm  
0.16 dwt  
14K Yellow, \$8.79



**3165**  
5.5×5.5mm  
0.17 dwt  
14K Yellow, \$9.69



**3632**  
5×6.75mm  
0.10 dwt  
14K Yellow, \$5.59



**3601**  
5.75×5.75mm  
0.14 dwt  
14K Yellow, \$7.83



**3674**  
7.75×6mm  
0.14 dwt  
14K Yellow, \$7.83



**3345**  
8.25×9.5mm  
0.18 dwt  
14K Yellow, \$10.01  
Available in 22 gauge only.



**3746**  
12×12.5mm  
0.48 dwt  
14K Yellow, \$26.80



**3548**  
27.75×18mm  
1.69 dwt  
14K Yellow, \$94.42



**3392**  
34.5×18.5mm  
3.61 dwt  
14K Yellow, \$202.05



**3394**  
37.25×13mm  
3.05 dwt  
14K Yellow, \$170.52

Stampings



**3141**  
20.5x11mm  
3.02 dwt  
14K Yellow, \$168.92



**3142**  
29x13mm  
4.08 dwt  
14K Yellow, \$228.04



**3140**  
21x11mm  
2.74 dwt  
14K Yellow, \$153.33



**3138**  
29x16mm  
4.06 dwt  
14K Yellow, \$227.31



**3139**  
21mm  
3.21 dwt  
14K Yellow, \$179.37



**3903**  
28.75x50.75mm  
8.78 dwt  
14K Yellow, \$491.00



**3904**  
28.75x50.75mm  
8.77 dwt  
14K Yellow, \$490.08  
\* Chain sold separately.



**3395**  
28.75x50.75mm  
8.95 dwt  
14K Yellow, \$500.45



**3902**  
28.75x50.75mm  
8.62 dwt  
14K Yellow, \$482.27



# STERLING SILVER COMPARISON

Differences Between Traditional Sterling Silver, Sterlium Plus®, and Continuum® Sterling Silver

For more information, visit [Stuller.com/MetalsCenter](http://Stuller.com/MetalsCenter).

## Investment Casting

	Traditional Sterling Silver	Sterlium Plus®	Continuum® Sterling Silver
<b>Notable Attribute</b>	Age-Old Traditional	Tarnish Resistant	Harder Sterling
<b>Casting Temperature</b>	970°C/1778°F	1010°C/1850°F	1010°C/1850°F
<b>Flask Temperature</b>	Adjust to size and weight of castings	Adjust to size and weight of castings	Adjust to size and weight of castings
<b>Casting Flux</b>	Boric acid - skim off before casting	Boric acid - skim off before casting	Boric acid - skim off before casting
<b>Quench Time (4" x 8" ) Flask</b>	15-20 minutes	20-25 minutes	5 minutes (for softer) 25 minutes (for harder)
<b>Investment Removal</b>	Any proprietary investment remover	Any proprietary investment remover	Any proprietary investment remover
<b>Pickling After Casting</b>	Required to remove black oxidation	Usually not required, castings are white	Minimally required, castings are light brown
<b>Reuse</b>	50% scrap/50% fresh metal	50% scrap/50% fresh metal	50% scrap/50% fresh metal
<b>NOTE</b>	Remove all investment residues before reuse	Remove all investment residues before reuse	Remove all investment residues before reuse

## Fabrication and Soldering

	Traditional Sterling Silver	Sterlium Plus®	Continuum® Sterling Silver
<b>Ingots Molds</b>	Use two-piece vertical molds. Note: Avoid using horizontal slot-type molds for ingot casting as a shrink down of the center of the ingot will cause an area of porosity down the center of the rolled or drawn stock. Preheat the mold and use a light oil or spray graphite to keep the metal from sticking.		
<b>Notable Attributes</b>	Traditional	Tarnish resistance, more malleable and ductile, no fire scale	Mildly more tarnish resistant, harder sterling, no fire scale, stone retention, more resistance to fire cracking, maintains form, resists misshaping, holds finish longer
<b>Pouring Temperatures</b>	982°C/1800°F	1030°C/1886°F	1030°C/1886°F
<b>Flux</b>	Borax or Boric acid - skim before pouring	Boric acid - skim before pouring	Boric acid - skim before pouring
<b>Quenching</b>	Quench quickly after pouring	Quench quickly after pouring	Quench quickly after pouring
<b>Rolling</b>	Take 50%-70% reduction before annealing	Take 50% reduction before annealing	Take 50% reduction before annealing
<b>Annealing</b>	676°C/1150°F, 20-30 minutes	676°C/1150°F, 20-30 minutes	676°C/1150°F, 20-30 minutes
<b>Pickling</b>	Ingots will need to be pickled to remove oxide	Ingots will need to be pickled to remove oxide	Ingots will need to be pickled to remove oxide
<b>Cleaning</b>	Scrub ingots clean before use	Scrub ingots clean before use	Scrub ingots clean before use
<b>Soldering</b>	Regular silver solders	Regular silver solders	Regular silver solders
<b>Fire Coat</b>	A fire coat should be applied	A fire coat should be applied	A fire coat should be applied
<b>Solder Flux</b>	Use plenty of flux for soldering	Use plenty of flux for soldering	Use plenty of flux for soldering

*Sterlium Plus is not suitable for Mokume processes and is not appropriate for reticulating sterling silver. Information provided by collaborative efforts from UPMR and Stuller, Inc.*



# METAL DRAWING AND FORMING

Metal Drawing, Forming, and Ring Sizers

Metal Drawing, Forming, and Ring Sizers

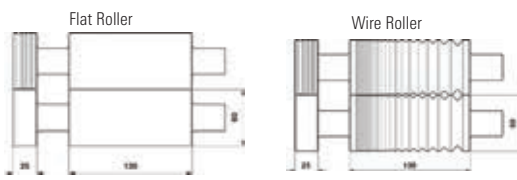

**DRM 130 DOUBLE-SIDED ROLLING MILL**  
 Durston bench-top power mills are the most sought after powers mills in the world. These mills have cast iron bases, cast iron gear boxes with powerful motors, and the standard one-piece cast iron mill frame incorporating our high quality steel rollers, which run on heavy duty roller bearings. 490 lbs.

- Model 130 DSP**
- Roll Size: 130 mm x 65 mm
  - Sheet Capacity: 6 mm
  - Width of Flat: 130 mm
  - Wire Capacity: 10-1 mm
  - Number of Wire Grooves: 19

Order #	WxDxH	Shipping Weight	1+
28-1991	16½"×8½"×21¼"	490 lbs	\$4,635.00



**TUI 130 DOUBLE-SIDED POWER ROLLING MILL**  
 Durston 130 double-sided power mill. Features include variable speed, powerful 1.1kw motor, forward and reverse, cast iron gear box, and two sets of extension rollers.

- Model TUI 130**
- Roll Size: 130 mm x 65 mm
  - Sheet Capacity: 6 mm
  - Width of Flat: 130 mm
  - Wire Capacity: 10-1 mm
  - Number of Wire Grooves: 19

Order #	WxDxH	Shipping Weight	1+
28-1990	33"×15"×22"	400 lbs	\$3,450.00



Model FSM 160

**FSM 160 FLOOR STANDING MILL**  
 Available in three speed configurations: fixed speed, variable speed, and a computer control panel that offers more information, such as roll speed, pressure and oil indicator, and work light.

- Forward and reverse
- Automatic lubrication to roll bearings
- 130 mill flat, 19 square grooves
- Powerful 4kw motor
- Heavy duty cast iron gear box
- Digital roll gap meter (optional)
- Work lights (optional) Requires special ordering and eight-week delivery. Shipping fees included for model FSM 160 Floor Standing Mill.

- Model FSM 160**
- Roll Size: 160 mm x 86 mm
  - Sheet Capacity: 25 mm
  - Wire Capacity: 1-9 mm
  - Number of Wire Grooves: 19

Order #	WxDxH	Shipping Weight	1+
28-1994	49"×19½"×58¼"	1,345 lbs	\$19,950.00

**DURSTON DOUBLE D2 130 ROLLING MILL**  
 As the first manual rolling mill incorporating roller bearings, this mill has two sets of rollers: one for flat (having extension rollers incorporating four half rounds) and the other grooved for square wire. Excellent gearing ratio offers reduction of 7 - 1 for flat and 3.5 - 1 for wire, allowing smooth manual operation. Features large, easy-to-read calibrated disc, extra wide flat area (19 grooves), and guide plate.

- Model DOUBLE D2 130**
- Roll Size: 130 mm x 60 mm
  - Sheet Capacity: 7 mm
  - Width of Flat: 130 mm
  - Gear Ratio: 7:1

Order #	WxDxH	Shipping Weight	1+
28-2006	16½"×8½"×22¼"	155 lbs	\$2,285.00

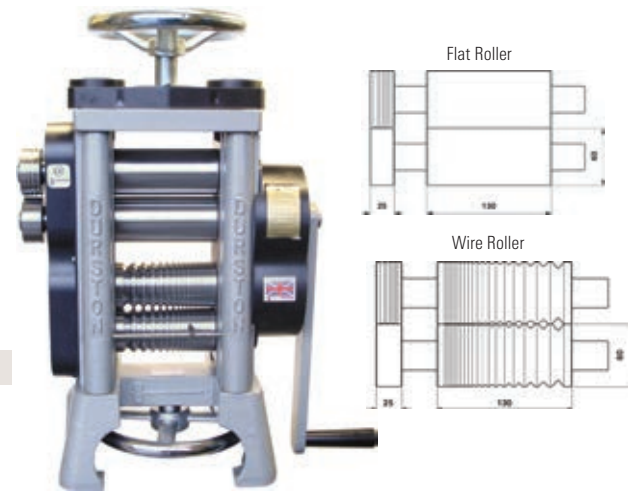

**DURSTON DRM C130 WITH REDUCTION**  
**Model C130 R**

- Roll Size: 130 mm x 60 mm
- Sheet Capacity: 7 mm
- Width of Flat: 80 mm
- Wire Capacity: 8-1 mm
- Number of Wire Grooves: 11
- Gear Ratio: 5:1

Order #	WxDxH	Shipping Weight	1+
28-1997	14"×9"×14"	101 lbs	\$1,035.00



**DURSTON DRM F130 ROLLING MILL WITH REDUCTION**  
**Model F130 R**

- Roll Size: 130 mm x 60 mm
- Sheet Capacity: 7 mm
- Width of Flat: 130 mm
- Gear Ratio: 5:1

Order #	WxDxH	Shipping Weight	1+
28-1998	16"×9"×14"	101 lbs	\$1,021.20



**DURSTON COMBINATION 130 ROLLING MILL**  
**Model C130 RE**

- Roll Size: 130 mm x 60 mm
- Sheet Capacity: 7 mm
- Width of Flat: 80 mm
- Wire Capacity: 8-1 mm
- Number of Wire Grooves: 11
- Gear Ratio: 5:1

Order #	WxDxH	Shipping Weight	1+
28-2005	16"×8½"×14"	105 lbs	\$1,335.00



All items are priced at jeweler's cost, are sold each, unless otherwise noted, and are subject to change without notice. Visit [Stuller.com](http://Stuller.com) for our complete product selections, current pricing, and quantity price breaks. | 403

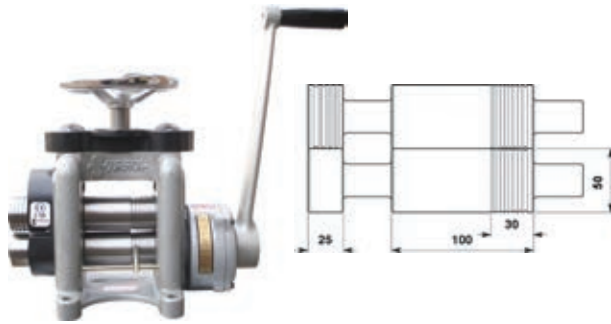

**Model C100 RE**

- Roll Size: 100 mm x 50 mm
- Sheet Capacity: 6 mm
- Width of Flat: 70 mm
- Wire Capacity: 7-1 mm
- Number of Wire Grooves: 9
- Gear Ratio: 4:1

Order #	WxDxH	Shipping Weight	1+
28-2004	14"×8"×12½"	76 lbs	\$1,095.00

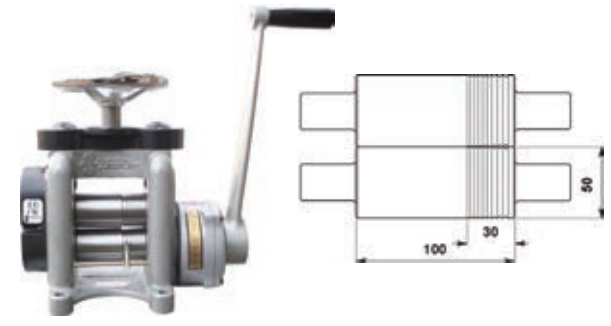

**Model C100 R**

- Roll Size: 100 mm x 50 mm
- Sheet Capacity: 6 mm
- Width of Flat: 70 mm
- Wire Capacity: 7-1 mm
- Number of Wire Grooves: 9
- Gear Ratio: 4:1

Order #	WxDxH	Shipping Weight	1+
28-1996	14"×8"×12½"	70 lbs	\$899.00

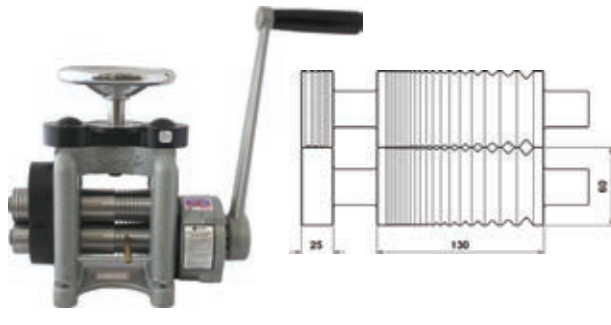

**Model DRM RF 100 RE**

- Roll Size: 100 mm x 50 mm
- Sheet Capacity: 5.5 mm
- Width of Flat: 45 mm
- Wire Capacity: 6-2 mm
- Number of Wire Grooves: 9
- Gear Ratio: 4:1

Order #	WxDxH	Shipping Weight	1+
28-1992	14"×8"×12½"	70 lbs	\$1,352.00



**Model MINI C80**

- Roll Size: 80 mm x 45 mm
- Sheet Capacity: 6 mm
- Width of Flat: 60 mm
- Wire Capacity: 6.5-1 mm
- Number of Wire Grooves: 4
- Gear Ratio: Direct
- Extension Rollers: Drive

Order #	WxDxH	Shipping Weight	1+
28-2002	10"×4½"×10"	38 lbs	\$725.00

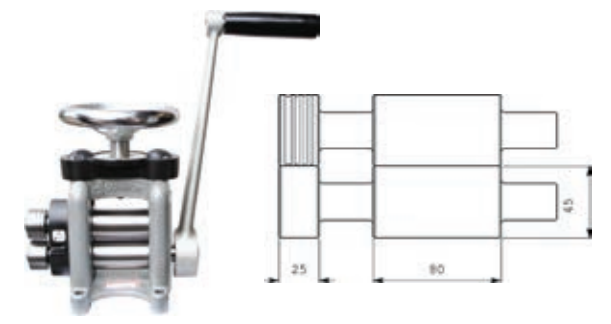

**Model MINI F80**

- Roll Size: 80 mm x 45 mm
- Sheet Capacity: 6 mm
- Width of Flat: 80 mm
- Gear Ratio: Direct
- Extension Rollers: Drive

Order #	WxDxH	Shipping Weight	1+
28-2003	10"×4½"×10"	38 lbs	\$728.00

**BEST-BUILT ROLLING MILLS**

These mills are manufactured in Korea, which is long known for their world-class steel. That high-quality steel, combined with a sleek, sturdy design, defines the Best-Built rolling mill. Best-Built rolling mills offer the same smoothness and reliability as higher priced European models. These are world-class rolling mills at a very competitive price.

**Order # 28-1980**

Description	WxDxH	1+
90mm	14½"×9¼"×12½"	\$745.00
110mm	15"×9¼"×12½"	\$895.00
130mm	15¾"×9¼"×12½"	\$1,335.00



**DURSTON BENCH**

This draw bench has a working length of 38", a 4:1 gear ratio, and can handle a maximum thickness of 10mm wire. German draw tongs included.

Order #	Description	WxLxH	1+
28-2009	Draw Bench	22"×55"×39"	\$1,020.00



183 lbs

**CABINET STAND**

Suited to the Durston D2 130 and D4 158 manual rolling mills. The stand is drilled and tapped with appropriate holes. Bolts are supplied for the mill required. The stand has excellent storage space with two shelves and a locking flush door with two keys. The construction is very sturdy and made of 0.25" plate steel. Finish is attractive metallic silver coated paint inside and out. The stand should be secured to floor using appropriate bolts.

**PEDESTAL STAND**

Suited to the Durston Mini Mill, DRM 130, and DRM150 manual mills. The stand is drilled and tapped with appropriate holes. Bolts are supplied for the mill required. The stand should be secured to floor using appropriate bolts.

Item	Order #	Description	WxDxH	12+	6+	1+
A	28-2007	Cabinet Stand	13¾"×13¾"×35⅞"	\$337.45	\$357.30	\$397.00
B	28-2008	Pedestal	11⅞"×13¾"×35⅞"	—	—	\$277.00



Metal Drawing, Forming, and Ring Sizers

Metal Drawing, Forming, and Ring Sizers



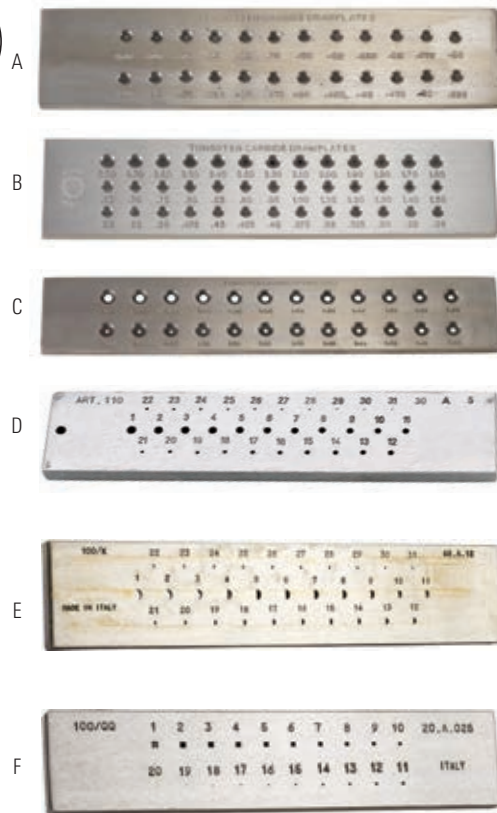

**TUNGSTEN-CARBIDE DRAWPLATES**

Tungsten-carbide inserts are permanently fixed in marked steel plate. Angle of reduction is made to exact specifications for the smoothest possible pull.

Item	Order #	Hole:		Number of Holes	12+	6+	1+
		Largest–Smallest					
A	28-0422	1mm - 0.26mm		24	\$46.71	\$49.46	\$54.95
B	28-0423	2.8mm - 0.26mm		39	\$54.40	\$57.60	\$64.00
C	28-0425	6mm - 2.3mm		24	\$72.89	\$77.18	\$85.75

**TOOL-STEEL DRAWPLATES**

Made of thick, high-grade tool steel with accurately machined and smoothly beveled holes, this allows wire to be drawn easily from larger holes to successively smaller holes to obtain the size and shape wire needed. Works on brass, copper, gold, silver, platinum, and soft steel wire. Plate is stamped with style identifying letter and hole sizes. Beeswax can be used as a lubricant. Plate Type Letter D D (Round) E K (Half-Round) F QQ (Square)

Item	Order #	Hole:		Number of Holes	12+	6+	1+
		Largest–Smallest					
D	28-0440	2.94mm - 0.56mm		31	\$66.26	\$70.16	\$77.95
E	28-0460	4.76mm - 2.38mm		30	\$141.06	\$149.36	\$165.95
F	28-0472	3.97mm - Filigree		20	\$80.75	\$85.50	\$95.00



**LOWELL PATTERN HAND VISE**

Combination hand vise ideal for gripping small objects or for use as a small draw tong. Made of forged steel. Long, firm grip handle and serrated jaws. Made in Poland.

Order #	Length	Jaw Width	12+	6+	1+
58-1412	5½"	½"	\$25.08	\$26.55	\$29.50



**DRAW TONGS**

Made of forged steel. Used to pull wire through drawplates. A strong grip is attainable due to the serrated jaws.

Order #	Description	Length	12+	6+	1+
57-0580	Draw Tong	10"	\$22.10	\$23.40	\$26.00



**DRAW TONGS**

Used to pull wire through draw plates. A strong grip is attainable due to the serrated jaws. Made in Germany.

Order #	Description	Length	12+	6+	1+
57-0581	Curved-End Draw Tong	10"	\$56.19	\$59.49	\$66.10



**DURSTON DISC CUTTER**

Durston's set now includes a set of shims for supporting the opposite side of the disc cutter while making cuts, cutting lubricant for helping to keep edges sharp and cutting action smooth, and a new urethane pad for absorbing hammer blows to minimize rebound shock.

Order #	Description	12+	6+	1+
25-0583	Disc Cutter 3-19	\$302.60	\$320.40	\$356.00
25-0582	Disc Cutter 3-32	\$254.15	\$269.10	\$299.00
25-0584	Disc Cutter 20-28	\$286.45	\$303.30	\$337.00
25-0585	Disc Cutter 29-34	\$270.30	\$286.20	\$318.00



**ASIC DISC CUTTER**

High precision disc cutter set, made in Poland.

Order #	Description	12+	6+	1+
25-0457	Disc Cutter Set	\$370.13	\$391.91	\$433.62

**DISC CUTTER COMBINATION SET**

Ikohe disk cutter is made with 11 punches ranging in exact inch sizes from 1/8" to 1". Made of hardened steel, this disc cutter is designed for easy separation, as the top can be removed completely by unscrewing the center hex nut. A hex key is provided for this, and the top portion has textured grips on the sides for ease of removal. The set includes a wood stan, with punch holes labeled in metric and inch sizing.

Order #	Description	12+	6+	1+
25-0579	Combination Set	\$145.86	\$154.44	\$171.60



**DURSTON DAPPING CUTTER/TEXTURING SET**

These dapping cutters are used to make creative designs. The sizes include 3mm, 4mm, 5mm, 6mm, 7mm, 8mm, 9mm, 10mm, 11mm, 12mm, 13mm, 14mm, 15mm, 17mm, 19mm, and 20mm..

Order #	Description	1+
25-1241	Dapping Cutter/ Texturing Set	\$131.25







**DURSTON DAPPING SET**

High-quality dapping set for the professional jeweler who demands the best. All pieces are hardened, ground, and highly polished for perfect results. Comes with 24 punches ranging from 3mm to 50mm (3-15, 17, 19, 21, 23, 25, 28, 32, 36, 40, 45, and 50mm). Matching 65mm square dapping block with 26 full half-spheres all fit into a neatly molded base with carrying handle.

Order #	Description	12+	6+	1+
25-1233	Large Set (24 punches)	\$299.20	\$316.80	\$352.00



A



B

C

D

**CUPOLA SETS**

High-quality dapping sets for the professional jeweler who demands the best. All pieces are hardened, ground, and highly polished for perfect results. All pieces fit into a unique plastic carrying tray.

Item	Order #	Description	Punches	Size	12+	6+	1+
A	25-1237	Large Cupola Set	6	50mm - 80mm	\$262.57	\$278.01	\$308.90
B	25-1234	Small Cupola Set	3	50mm - 57mm	\$63.75	\$67.50	\$75.00
C	25-1235	Medium Cupola Set	2	57mm - 64mm	\$90.95	\$96.30	\$107.00
D	25-1236	Large Cupola Set	2	78mm - 85mm	\$119.00	\$126.00	\$140.00



**DELUXE DAPPING SET**

This dapping set includes a 2" dapping block with 18 depressions and 24 dapping punches. Punches range in size from 9/64" to 1" and are composed of case-hardened steel for years of excellent performance. Also included is a 2" dapping block and a wooden stand to keep it all organized.

Features—

- Wood stand
- 2" dapping block with 18 depressions
- 24 dapping punches
- Case-hardened
- Punch sizes: 1", 15/16", 7/8", 13/16", 25/32", 3/4", 23/32", 11/16", 5/8", 19/32", 9/16", 1/2", 15/32", 17/16", 13/32", 3/8", 5/16", 9/32", 1/4", 7/32", 5/32", 7/32", 5/32", 7/64", 1/8", 9/64"
- Depression sizes: 35, 31, 28, 25, 21, 20, 19, 17, 15, 14, 12, 11, 9, 8, 6, 5, and two 3mm

Order #	Description	WxLxH	12+	6+	1+
25-0575	Dapping Set	4 1/2"x8"x5 1/2"	\$70.64	\$74.79	\$83.10

**DAPPING DIES AND BLOCKS**

Hardened steel design blocks are used to form hemispheric depressions on different metals. Grooved edges are used for shaping and bending rings, settings, bezels, and other items.

A and B. **17 Round** depressions measuring up to 1 3/4" in size on a hardened steel square die.

C. **27 Round** depressions measuring 1.5mm - 25mm. Used in conjunction with dapping punches to produce hemispheres.

D. **17 Round** depressions - 2mm, 3mm, 3.5mm, 4mm, 4.5mm, 5mm, 5.5mm, 6mm, 7.5mm, 8mm, 8.5mm, 9mm, 11mm, 11.5mm, 13mm, 17mm, 20mm; five Oval depressions - 12.5mm x 19.5mm, 14.5mm x 19mm, 15mm x 22mm, 20mm x 27mm, 18mm x 26.5mm

**Three V-shaped** grooves - (w x d) - 4mm x 1.5mm, 5mm x 2mm, 6mm x 3mm  
**20 Half-Round** grooves - 2mm x 1.5mm, 3mm x 1.75mm, 3mm x 1.25mm, 3mm x 1mm, 3mm x 2mm, 3mm x 1.5mm, 5mm x 2mm, 5mm x 2.25mm, 6mm x 2.5mm, 6mm x 3mm, 7mm x 3mm, 8mm x 4mm, 9mm x 3.5mm, 10mm x 4mm, 12mm x 4mm, 14mm x 5mm, 17mm x 6mm, 20mm x 7mm, 21mm x 7mm, 24mm x 8mm

Item	Order #	Description	W x L x H	12+	6+	1+
A	25-0570	17 Depressions	2 1/2"	\$40.76	\$43.16	\$47.95
B	25-0571	17 Depressions	2"	\$32.26	\$34.16	\$37.95
C	25-0550	27 Depressions	2 1/2" x 5 1/2" x 3/4"	\$84.32	\$89.28	\$99.20
D	25-0440	22 Depressions	35mmx220mmx35mm	\$37.44	\$39.65	\$44.05

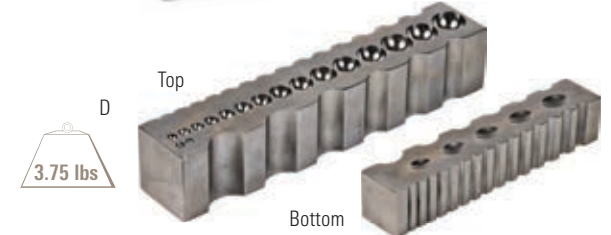
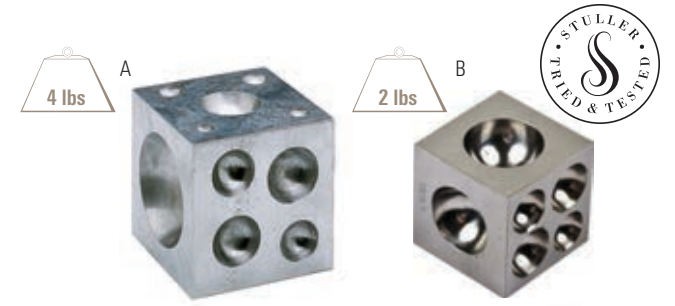

**DURSTON 23 HOLE DAPPING BLOCK**

This dapping block has 23 half spheres in sizes 3mm, 4mm, 5mm, 6mm, 7mm, 8mm, 9mm, 10mm, 11mm, 12mm, 13mm, 14mm, 15mm, 16mm, 17mm, 19mm, 21mm, 23mm, 25mm, 27mm, 30mm, 34mm, and 38mm

Item	Order #	Description	WxLxH	12+	6+	1+
E	25-0581	Dapping Block	3 1/4"x5 3/4"x1 1/4"	\$76.50	\$81.00	\$90.00



**DURSTON 14 DEPRESSION FORMING BLOCK**

This forming block has 14 half spheres in sizes 5mm, 6mm, 7mm, 8mm, 9mm, 10mm, 11mm, 13mm, 15mm, 16mm, 17mm, 22mm, 23mm, and 24mm. There are also 8 half cut outs in sizes 5mm, 6mm, 8mm, 9mm, 15mm, 16mm, 17.5mm, 22mm, and 26mm

Item	Order #	Description	WxLxH	12+	6+	1+
F	25-0580	Forming Block	2 1/2"x3 3/4"x1"	\$96.90	\$102.60	\$114.00



**GRS® METAL FORMER**

Easily shape C-style bracelets with the GRS Bracelet Former. Form flat strips of metal to a perfect C shape after you have engraved your design. The die cup contains a soft alloy material that supports pressure from the die, but does not distort your engraving work. The die cup material can be reformed by heating when necessary.

Order #	Description	12+	6+	1+
G 25-0574	Metal Former	\$260.10	\$275.40	\$306.00





**FLAT DAPPING SET WITH BLOCK**  
Set includes high-grade, hardened steel with 14 hemispherical depressions in two rows. Graded in 1/16" increments from 1/8" to 7/8" plus 1" and 11" matching punches. Block measures 5 1/8"x2 1/2"x3/4".

Order #	Description	12+	6+	1+
25-0573	Flat Dapping Set with Block	\$74.93	\$79.34	\$88.15

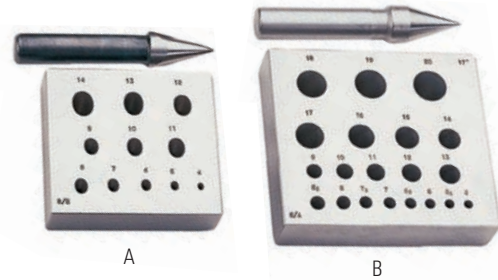

**BEZEL BLOCKS AND PUNCHES**  
Bezel blocks and punches are used to form various shapes of conical bezels. Made from a hardened, tempered steel. Made in Italy.

Item	Order #	Description	12+	6+	1+
A	25-0600	Oval Bezel Block	\$165.75	\$175.50	\$195.00
B	25-0602	Round Bezel Block	\$106.25	\$112.50	\$125.00



**GRADUATED DAPPING BLOCK AND PUNCH SET**  
This large, double-sided hardwood block features 10 machined half spheres, clearly marked with the disc size they accept (65mm-16mm) and matching punches. Concave dimensions largest to smallest: 2 1/2" to 5/8" (65mm-16mm).

Order #	Description	WxLxH	12+	6+	1+
25-1353	Shaping Block	4"x7"x3"	\$72.25	\$76.50	\$85.00

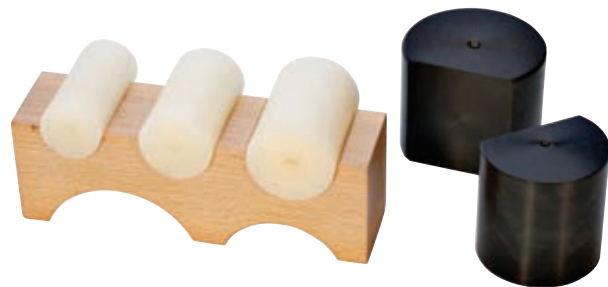

**BENDING BLOCK WITH NYLON FORMING ROLLER**  
This high-quality hardwood forming block is great for bending and forming without marring. Lighter weight and less expensive than the steel version, the large grooves consist of three half-round (1 1/4", 1 1/2", 1 3/4") and two larger third-round (2 1/2", 3 1/4") channels.

Order #	Description	WxLxH	12+	6+	1+
25-0444	Bending Block	1 1/8"x7x2 3/8"	\$37.40	\$39.60	\$44.00



**LEATHER SANDBAG**  
This 8" leather sandbag is great for stamping, chasing, and forming. Helps to deaden the blow and sound when striking a piece.

Item	Order #	OD	12+	6+	1+
C	25-0000	6"	\$22.10	\$23.40	\$26.00
D	25-0001	8"	\$25.50	\$27.00	\$30.00



**WOOD DAPPING BLOCK AND PUNCHES**  
Handmade, hardwood block with six depressions, one on each side. Block measures 2 1/4" square. Includes two punches. Use block in combination with punches to shape lockets, cases, and remove dents.

Order #	Description	12+	6+	1+
25-1350	Dapping Block with Punches	\$11.05	\$11.70	\$13.00

**METRIC TAP AND DIE SET**

Precision metric tap and die set consists of eight dies covering the range from 1mm to 3mm. Also included is a die holder, adjustable tap holder, eight sets of three right taps (total 24), and a fitted hardwood case. Made in Germany.

Order #	Description	1+
25-2002	Metric Tap & Die Set	\$438.00



**CALIBRI TAP AND DIE SET**

With special wide pitch on tap for precious metal. For the most common sizes, the number of holes are doubled on the plate.

Order #	Description	12+	6+	1+
25-2003	Tap and Die Set	\$123.25	\$130.50	\$145.00



**LETTER STAMP SET (27 PIECES)**

Hardened steel stamps of the complete alphabet and a period come in a hardwood storage box. Made in the USA.



Order #	Impression	Length	12+	6+	1+
55-2551	1/16 inch (1.6mm)	2 3/8"	\$50.15	\$53.10	\$59.00
55-2552	1/8 inch (0.8mm)	2 3/8"	\$51.51	\$54.54	\$60.60
55-2550	1/16 inch (1.6mm)	2 3/8"	\$19.55	\$20.70	\$23.00



**STEEL STAMPS**

All stamp diameters 1/4". Stamp lengths 2 3/8".  
A Character size: 1/16". Figures: 0-8 (Use 6 as 9)  
B Character size: 3/32". Figures: 0-8 (Use 6 as 9)  
C Character size: 1/16". Figures: A-Z and period mark  
D Character size: 3/32". Figures: A-Z and period mark



Item	Order #	Description	Assortment Qty	Size	12+	6+	1+
A	55-2540	Numbers 0-8	9	1/16"	\$20.61	\$21.83	\$24.25
B	55-2541	Numbers 0-8	9	3/32"	\$20.61	\$21.83	\$24.25
C	55-2542	Letters A-Z	27	1/16"	\$46.84	\$49.59	\$55.10
D	55-2543	Letters A-Z	27	3/32"	\$46.84	\$49.59	\$55.10

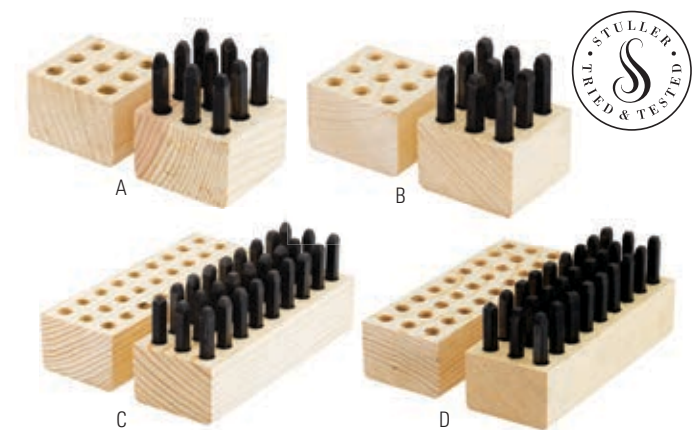

**BRASS STAMPING ANVIL**

Brass anvil with graduated sizes within specific shapes prevents flat spotting while stamping. One side is for women's rings, and one side is for men's rings.

Order #	Description	WxLxH	12+	6+	1+
55-3340	Brass Stamping Anvil	1 1/4"x3"x3/4"	\$19.25	\$20.39	\$22.65





**PUNCH AND BRASS HAMMER SET (13PC)**

The Altraco OPH-10 13-piece Brass Punch Set with Brass Hammer is a mixed set with solid brass, steel, and plastic punches. Designed for a variety of tasks, the 12 punches in the kit are 3 1/6" long with knurled handles: two black finish steel punches (1/16" and 3/32"), two black finish plastic punches (1 5/64" and 3/8"), eight brass punches (1/8", 5/16", and 3/64"). The one-piece brass hammer weighs eight ounces.

Order #	Description	1+
25-1348	Punch & Brass Hammer Set	\$26.00



**BENT RING STAMPS #2 (SET OF SIX)**

Steel, precision-cut bent ring stamps. Set includes six pieces in case. Includes stamps for 10K, 14K, 18K, 925, PLAT, and sterling silver.

Order # 55-3337	Item	Description	12+	6+	1+
	A	Set of 6	\$84.96	\$89.96	\$99.95
	B	10K Stamp	\$12.71	\$13.46	\$14.95
	C	14K Stamp	\$12.71	\$13.46	\$14.95
	D	18K Stamp	\$12.71	\$13.46	\$14.95
	E	925 Stamp	\$12.71	\$13.46	\$14.95
	F	PLAT Stamp	\$13.56	\$14.36	\$15.95
	G	STER Stamp	\$13.56	\$14.36	\$15.95



**PRECIOUS METAL HAND STAMPS**

Made of hand-cut steel to stamp impressions on metal surfaces. Bent: 1/32" (0.8mm) 1/45" (0.6mm) Straight: 1/32" (0.8mm) 1/45" (0.6mm)

Order #	Description	Metal	Type	12+	6+	1+
55-3335	Palladium	1/32"	Bent	\$20.15	\$21.33	\$23.70
55-3336	Palladium	1/32"	Straight	\$20.15	\$21.33	\$23.70
55-3230	Platinum	1/45"	Bent	\$22.14	\$23.45	\$26.05
55-2722	18K	1/32"	Bent	\$16.36	\$17.33	\$19.25
55-2723	18K	1/45"	Bent	\$16.36	\$17.33	\$19.25
55-2622	14K	1/32"	Bent	\$16.36	\$17.33	\$19.25
55-2623	14K	1/45"	Bent	\$16.36	\$17.33	\$19.25
55-2922	14K	1/32"	Straight	\$16.36	\$17.33	\$19.25
55-2923	14K	1/45"	Straight	\$16.36	\$17.33	\$19.25
55-2522	10K	1/32"	Bent	\$16.36	\$17.33	\$19.25
55-2523	10K	1/45"	Bent	\$16.36	\$17.33	\$19.25
55-3022	Sterling	1/32"	Bent	\$22.53	\$23.85	\$26.50
55-3023	Sterling	1/45"	Bent	\$22.53	\$23.85	\$26.50
55-3122	Sterling	1/32"	Straight	\$22.95	\$24.30	\$27.00
55-3123	Sterling	1/45"	Straight	\$22.95	\$24.30	\$27.00
55-3222	Copyright - ©	1/32"	Bent	\$21.12	\$22.37	\$24.85
55-3223	Copyright - ©	1/45"	Bent	\$17.00	\$18.00	\$20.00
55-3322	Copyright - ©	1/32"	Straight	\$21.55	\$22.82	\$25.35



**JEWELRY MARKING MACHINE**

Make perfect impressions and identification markings on all rings, charms, disks, or any flat pieces. Kit includes spring-action lever machine with automatic return to upright positions, six punches (one each in bent and straight: 10K, 14K, 18K), and three nylon anvils. Wooden base has storage for spare parts.

Order #	Description	12+	6+	1+
55-2553	Jewelry Marking Machine Kit	\$363.42	\$384.80	\$427.55
55-2554	Nylon Anvil	\$3.61	\$3.83	\$4.25
55-2555	10K Straight Punch	\$36.68	\$38.84	\$43.15
55-2556	14K Straight Punch	\$36.68	\$38.84	\$43.15
55-2557	18K Straight Punch	\$36.68	\$38.84	\$43.15
55-2558	10K Bent Punch	\$42.59	\$45.09	\$50.10
55-2559	14K Bent Punch	\$42.59	\$45.09	\$50.10
55-2560	18K Bent Punch	\$42.59	\$45.09	\$50.10
55-2561	Sterling Straight Punch	\$83.26	\$88.16	\$97.95



**STAINLESS STEEL JEWELRY MARKING PLIERS**

Use to stamp precious metals with karat stamps using little pressure on curved or flat surfaces. No setup or hammering required. Stamp inside rings as small as size four. Made of durable stainless steel. Adjustable screw-locks stamp in place. Punches sold individually.

Order #	Description	Length	12+	6+	1+
46-2400	Marking Pliers	5 1/2"	\$65.45	\$69.30	\$77.00
46-2410	Replacement Nylon Anvil		\$3.40	\$3.60	\$4.00
55-2401	10K Punch		\$21.46	\$22.73	\$25.25
55-2402	14K Punch		\$21.46	\$22.73	\$25.25
55-2403	18K Punch		\$21.46	\$22.73	\$25.25
55-2407	Sterling Silver Punch		\$21.46	\$22.73	\$25.25



**RING SHANK BENDER**

Superior precision made for great performance, the complete unit sits into a 200mm diameter base with lifting handles. The does are hardened and polished. The base holder with screws allows you to bolt the piece to your bench or use strip to clamp into vice. The unique geared system gives great reduction to make bending effortless.

Order #	Description	12+	6+	1+
48-7537	Durston Rolling Mill	\$204.85	\$216.90	\$241.00



Metal Drawing, Forming, and Ring Sizers

Metal Drawing, Forming, and Ring Sizers





**GRS® RING SIZE CUTTER**

This ring cutter saves time by neatly shearing a controlled amount of ring shank material. The ring remains perfectly parallel so your soldering is neat and fast. Comes with seven different size blades: 1/2, 3/4, 1, 1 1/4, 1 1/2, 1 3/4, and 2. These sizes correspond to the change in ring size. Blades change quickly and easily with no tools. Replacement blades sold separately.

Item	Order #	Description	12+	6+	1+
A	26-4150	Ring Size Cutter	\$263.42	\$278.91	\$309.90
B	26-4176	1 1/2	\$13.43	\$14.22	\$15.80
C	26-4175	1 1/4	\$13.05	\$13.82	\$15.35
D	26-4174	1	\$13.13	\$13.91	\$15.45
E	26-4173	3/4	\$12.75	\$13.50	\$15.00
F	26-4178	2	\$16.07	\$17.01	\$18.90
G	26-4172	1/2	\$12.37	\$13.10	\$14.55

5 lbs

24 lbs



**DURSTON RING STRETCHER/REDUCER**

High precision ring stretcher/reducer featuring a six spline mandrel and 12 polished countersunk dies. This high-quality ring stretcher ensures exceptionally accurate ring sizing. Its countersunk, polished steel, reducing plate will reduce bands up to 12mm wide.

Item	Order #	Description	1+
A	48-7512	Stretcher/Reducer	\$391.00
B	48-7512	Stretcher/Reducer & Bender w/dies	\$399.00



**RING STRETCHER WITH REDUCTION WHEEL**

Allows reduction or enlargement of rings. Has six-spline mandrel. Graduated in US sizes. This upright style has a reversible base plate with 16 smoothly honed reduction dies that will not scratch. Allows for reducing bands by compression. Italian-made.

Item	Order #	Description	Ring Sizes	12+	6+	1+
C	48-7510	Stretcher with Reduction Wheel	3-15	\$336.39	\$356.18	\$395.75

18 lbs

**RATHBURN RING STRETCHER**

Perfect for stretching rings size 6 or larger. Simply tapping the end spreads the outer mandrel and stretches the ring. Not for use on stone-set rings.

Item	Order #	Description	12+	6+	1+
D	48-7550	Ring Stretcher	\$12.71	\$13.46	\$14.95

**MANUAL RING STRETCHER**

Italian-made ring stretcher assures the finest quality with six-spline mandrel graduated in US sizes 3 1/2 to 15. This compact, upright style saves much needed bench space. Economical yet very durable tool for ring stretching. Easily and securely bolts to bench. 13 1/2 lbs.

Order #	Description	12+	6+	1+
48-7500	Ring Stretcher	\$202.47	\$214.38	\$238.20



**RING ENLARGER**

This tool allows you to roll out ring shanks to enlarge stone-set rings. Includes a roller for flat, wide shanks and a series of half-round concave rollers for shanks up to mm wide. Total of 16 rollers. Made in the USA.

Order #	Description	12+	6+	1+
48-7540	Ring Enlarger	\$58.40	\$61.83	\$68.70

31 lbs



**DURSTON JUMP RING MAKER**

Quickly fabricate the jump ring you need. Durston's Jump Ring Maker features 20 different mandrel sizes, and it works seamlessly with both Dremel® and Foredom® flex shafts. The new, high steam coiler provides more room for your hands, allowing you to work with speed and comfort.

Special features include the following:

- Coil holder with screws to bolt down to your bench for safety.
- Two different size V Grooves in Coil Holder.
- Increased mandrel length (120mm long) and increased coil holder length.
- High steam coiler enabling more room for your hands.
- Coil winder can be bolted anywhere to your bench or to the tray provided.
- 20 mandrel sizes.
- Compact base measures 110 x 185 x 155 high.
- Durston lubricant and one blade supplied as standard
- Suitable for both Dremel® and Foredom® flex shafts.

Order #	Description	12+	6+	1+
48-7514	The Ringer	\$212.50	\$225.00	\$250.00



**KAGAN RING STRETCHER/REDUCER**

Reduce and enlarge wedding bands up to size 14. Reducing disc has 12 different sizes, and the mandrel has eight splines. Made in the USA.

Item	Order #	Description	Ring Sizes	W×H	12+	6+	1+
H	48-7520	Kagan Ring Sizer	2-14	16"×18"	—	—	\$590.00
J	48-7535	Kagan Replacement Sleeve			\$139.10	\$147.29	\$163.65

17 lbs

Metal Drawing, Forming, and Ring Sizers

Metal Drawing, Forming, and Ring Sizers



# PLATING SUPPLIES



## SELF-CONTAINED BEAKER PLATING UNITS

These apparatuses are equipped with two or four tanks in pyrex glass of (two liter capacity each), with separate power supply. The degreasing tank has a fixed voltage of 7.5 volts, 10 A max., the rhodium plating tank has voltage adjustable by potentiometer on the control panel from 0 to 5.0 volts, 8.0 A (and 0 to 12 volt, with voltage selector switch, for use with the galvanic stylus), and electronic overload and short-circuit protection with automatic reset. The plant is provided with heating, with temperature control located on the control panel and sensor immersed in the electrolytic bath for accurate temperature control. The machine also includes two adjustable terminal boards 0-5.0 volts 8.0 A, and is complete with stainless steel anodes in the right-hand tank for degreasing, and titanium mesh anodes in the left-hand tank for rhodium plating.

Item	Order #	Description	1+
A	45-4081	Digital Four Breaker Plating Unit	\$2,370.88
B	45-4080	Digital Two Beaker Plating Unit	\$1,546.22

## ACCESSORIES

Item	Order #	Description	12+	6+	1+
C	45-4080	Titanium Mesh Anode for Two Beaker Plating Unit	\$93.70	\$97.78	\$101.85
D	45-4081	Titanium Mesh Anode for Four Beaker Plating Unit	\$109.34	\$114.10	\$118.85
E	45-4082	Stainless Steel Anode for L2 Plating Unit	\$26.04	\$27.17	\$28.30
F	45-4082	Stainless Steel Anode for L1 Plating Unit	\$26.04	\$27.17	\$28.30
G	45-4083	Copper Wire Supports (5 Hooks)	\$31.28	\$32.64	\$34.00
H	45-4084	Copper Wire Supports (10 Hooks)	\$33.35	\$34.80	\$36.25
J	45-4085	Copper Wire Supports (15 Hooks)	\$39.61	\$41.33	\$43.05
K	45-4086	In Line Vacuum System	\$196.79	\$205.34	\$213.90

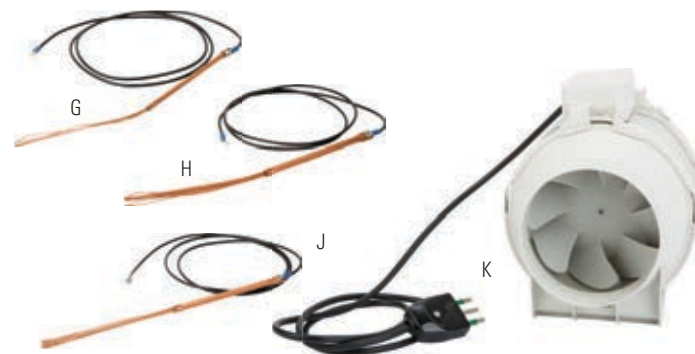
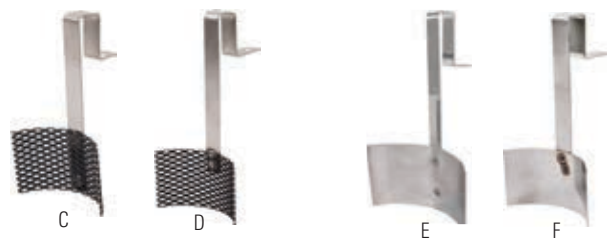

## BEAKER PLATING KIT

Beaker plating kit is comprised of high-quality components. Durable items will stand the test of time and can be depended on for years to come.



Order #	Description	1+
45-2000	Beaker Plating Kit	\$789.90



## 25-AMP PLATING KIT

Stuller is proud to offer to our customers a premium rhodium plating kit comprised of high-quality components. We put this kit together with the bench jeweler in mind. Durable items will stand the test of time and can be depended on for years to come. When compared to our competitor's kits, it is easy to see that we listen to what our customers want and that is quality, durability, and dependability. The kit is priced right and is perfect for the jeweler looking to set up a rhodium plating section or for the jeweler looking for an upgrade.



Order #	Description	1+
45-0151	25 Amp Plating Kit	\$550.00



## RHODIUM PLATING KIT

Premium rhodium plating kit is comprised of high-quality components. This kit was created with the bench jeweler in mind. Durable items will stand the test of time and can be depended on for years to come. Perfect for the bench jeweler looking to set up a rhodium plating section or for the jeweler looking to upgrade.



Order #	Description	1+
45-0150	Rhodium Plating Kit	\$580.00







**QUATRO RHODIUM HOOD**

- Eliminates odor, vapors, and particulate matter migrating throughout the workplace
- Illuminated work area
- Small footprint friendly
- Can operate 24/7, allowing beakers to be left inside contained area
- Designed for quiet operation
- Can be ducted to the outside

Order #	Description	W×H×D	Assortment Qty	1+
47-6010	Fume Hood	29"×38½"×20"		\$1,249.00
REPLACEMENT FILTERS				
47-4090	Dust Filter		1	\$10.05
47-4216	HEPA Filter		1	\$139.10
47-4091	Odor Cartridge Filter		1	\$150.50
47-4093	Odor Filter F1 Rhodium Plating		1	\$176.75
47-6011	Filter Kit (all 4 filters)		4	\$331.60

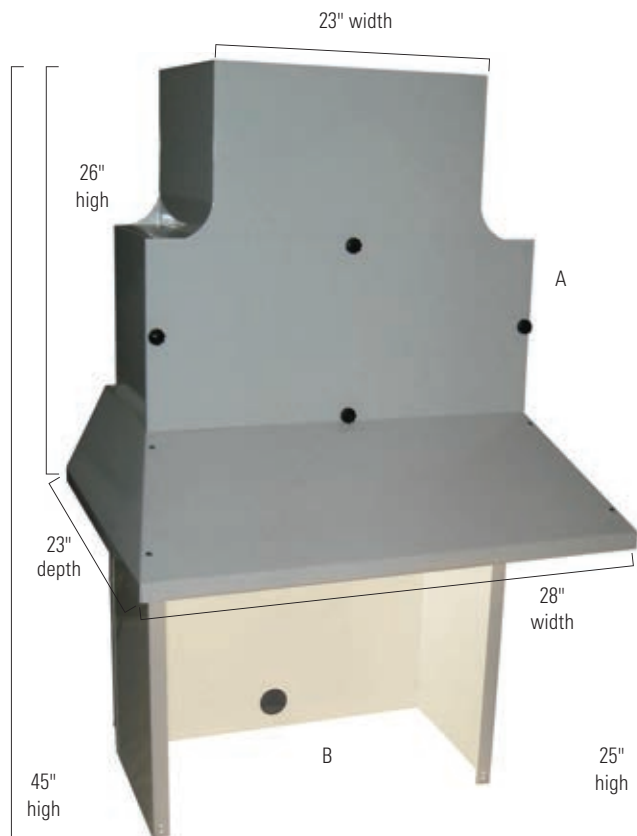

**QUATRO DUCTLESS FUME HOOD DHF1000-B FOR RHODIUM**

Capture odors via the Quatro Ductless Fume Hood and recirculate fresh air back into the room. Ideal for shops where it is difficult to access an outside wall, where you are not allowed to drill through an outside wall, or it is too costly to install duct work on the roof. Engineered to effectively work with the removal of plating fumes, three-stage filtering process features a maintenance-friendly design. Hood and stand sold separately.

- Overall Dimensions: 28" W x 23" D x 45" H
- Stand Dimensions: 22½" W x 25" H x 12" D
- Intake hood: 28" W x 26" H x 23" D
- Weight: Operating 50 lbs
- Voltage: 115V/60Hz, 1 amp



Item	Order #	Description	Assortment Qty	1+
A	47-3085	Ductless Fume Hood		\$1,164.00
B	47-4101	Counter Stand		\$278.60
REPLACEMENT FILTERS				
	47-4086	Dust Filters	8	\$79.25
	47-4087	#1 Odor Filter	1	\$160.60
	47-4092	Odor Filter Refill	2	\$123.25
	47-3088	Odor Neutralizing Container and Filter	1	\$202.60
	47-4069	Odor Filter Refill Only	5	\$181.10
	47-3087	HEPA Filter	1	\$129.30

Important! Remove wax elimination tray from the furnace after wax is melted out of flasks. Residue from burnt wax will greatly shorten life of heating elements and/or cause damage to the furnace.

**RECTIFIER**

Features industrial-grade, heavy-duty high-output transformers, oversized heat sinks, built-in cooling fan to prevent overheating, and an output current that is 99% filtered to ensure maximum and repeatable results. Insulated lead and clamp set. Adjustable voltage from 0-13v.

Order #	Description	Amp	1+
45-4044	Rectifier with Leads	25 amp	\$356.40



**PLATING RECTIFIER**

Precision built in the USA, these continuous-duty, solid-state electronic units feature a range of power to handle all plating needs. Works by means of the powerstat control to produce desired voltage. All units have pilot lights and both DC ammeter and voltmeter for measuring current under load. All units come with a set of lead wires with alligator clamps and terminal lugs. Specification for 10A

- 0 to 10 amps output, continuous duty
- 0 to 10 volts DC output
- Runs plating baths up to one gallon (3.81) except for rhodium, which is two quart (1.91)
- Steel cabinet measures 13" W x 8" H x 8½" D (330mm x 203mm x 216mm)

Order #	Description	1+
45-4030	10A Plating Rectifier	\$389.95
45-4037	10A Terminal Plating Lead	\$12.25



**HOT PLATE**

With three-ring tubular burners and infinite control switch, these units have chrome tops and 120V AC with three-prong grounded cord. Shipping weight 6 lbs.

- Single burner measures 8½" x 8½" x 3¼"
- Dual burner measures 17" x 8½" x 3¼"

Item	Order #	Description	Amps	Watts	1+
A	45-7119	Single Burner	6 amps	700 watts	\$56.05
B	45-7120	Double Burner	12 amps	1400 watts	\$95.35





**GLASS BEAKER**

- Low-expansion borosilicate 3.3 glass
- Designed to be heat-resistant and non-conductive
- Heavy and uniform wall thickness
- Easy pour spouts and white printed graduation and marking area

Order # 45-6412

Item	Size	12+	6+	1+
A	30ml	\$2.84	\$3.24	\$4.05
B	100ml	\$8.75	\$10.00	\$12.50
C	250ml	\$3.19	\$3.64	\$4.55
D	600ml	\$6.37	\$7.28	\$9.10
E	1200ml	\$10.33	\$11.80	\$14.75



**PYREX BEAKER**

These beakers are designed to be non-conductive and heat-resistant. Beakers are used to heat solutions during plating. To avoid spillage, beaker covers are available. Covers sold separately.

Order # 45-64000

Item	Description	Size	12+	6+	1+
F	Beaker	250 ml	\$5.53	\$5.85	\$6.50
G	Beaker	600 ml	\$10.44	\$10.90	\$11.35
H	Beaker	1,100 ml	\$19.41	\$20.26	\$21.10
J	Beaker	2,000 ml	\$22.54	\$23.52	\$24.50
K	Cover (for 600 ml)		\$5.14	\$5.45	\$6.05
L	Cover (for 1,000 ml)		\$5.57	\$5.81	\$6.05



**STAINLESS STEEL BEAKERS**

Made of all stainless steel, these beakers are perfect for holding electrocleaner or used in lieu of a stainless steel anode when a solution requires one. To avoid spillage, beaker covers are available. Covers sold separately.

Order # 45-64010

Item	Size	Container Volume	12+	6+	1+
M	Beaker	600 ml	\$52.12	\$54.38	\$56.65
N	Beaker	1,200 ml	\$73.14	\$76.32	\$79.50
P	Cover (for 600 ml)		\$5.14	\$5.45	\$6.05
Q	Cover (for 1,200 ml)		\$5.57	\$5.81	\$6.05

**PLATING ANODES**

Anodes are used for the purpose of introducing electrical current and/or replenishing the metal ions in the plating bath. The stems of all anodes may be bent to hang on the edge of the beakers. There are two types of anodes:

**Soluble** — Copper, nickel, and silver anodes dissolve into the bath, replacing metal ions as they are deposited onto the work piece during plating.

**Inert** — Our stainless steel and platinum-clad anodes do not dissolve in the plating bath. Prices on anodes will fluctuate due to metal market prices.

Item	Order #	Description	W×L	12+	6+	1+
R	45-0320	Platinized Titanium	¼"×10¼"	\$51.20	\$53.42	\$55.65
S	45-0321	Platinized Titanium	1"×4"	\$36.42	\$38.57	\$42.85
T	45-0323	Platinized Titanium	2"×3"	\$52.91	\$56.03	\$62.25
U	45-0322	Stainless Steel 304	½"×6"	\$4.60	\$4.80	\$5.00
V	45-0324	Copper	1"×6"	\$4.83	\$5.04	\$5.25
W	45-0326	Stainless Steel	1"×6"	\$5.93	\$6.19	\$6.45
Y	45-0330	Nickel	1"×6"	\$6.07	\$6.34	\$6.60
Z	45-0334	24K Gold	¾"×1"	\$138.00	\$144.00	\$150.00

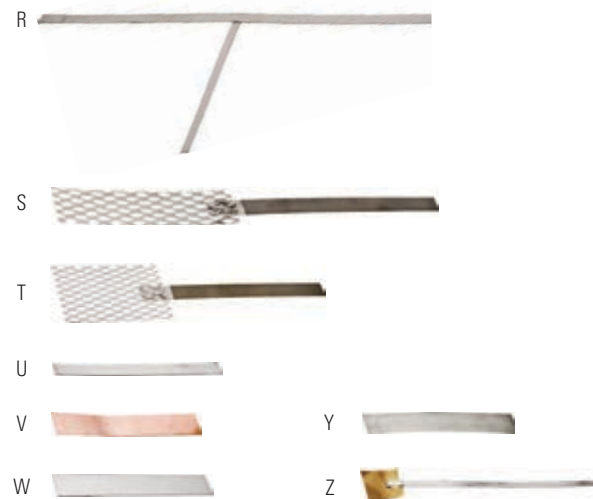

**IMMERSION THERMOMETER**

Indispensable for proper rhodium and palladium plating. Use to determine solution temperature. Temperature range 1-230°F.



Order #	Description	12+	6+	1+
45-6420	Immersion Thermometer	\$38.97	\$41.27	\$45.85

**PLATING RACKS**

Well designed in rows with numerous hooks, these racks are made of heavy gauge, poly-coated copper for protection when immersed in plating baths.

Order # 45-04000

Item	Diameter	Rows	Hooks	12+	6+	1+
A	2"	1	8	\$28.99	\$30.69	\$34.10
B	3"	1	12	\$26.69	\$28.26	\$31.40
C	3"	2	24	\$41.48	\$43.92	\$48.80

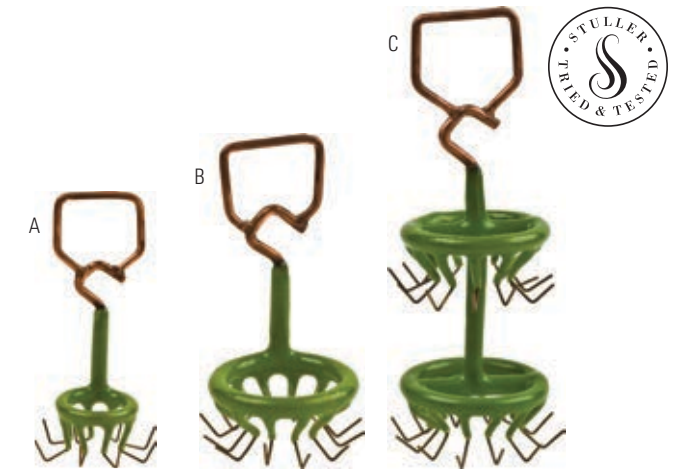

**COPPER PLATING WIRE**

All-purpose wire for plating.

Order # 43-64210

Description	Wire Gauge	Unit Weight	12+	6+	1+
Plating Wire	18	4 oz	\$7.74	\$8.19	\$9.10
Plating Wire	20	4 oz	\$7.74	\$8.19	\$9.10
Plating Wire	21	1 oz	\$7.74	\$8.19	\$9.10
Plating Wire	22	4 oz	\$7.74	\$8.19	\$9.10



**BRASS PLATING WIRE**

All-purpose wire for plating.

Order # 43-51200

Description	Wire Gauge	Unit Weight	12+	6+	1+
Brass Plating Wire	18	4 oz	\$9.95	\$10.53	\$11.70
Brass Plating Wire	20	4 oz	\$10.76	\$11.23	\$11.70
Brass Plating Wire	22	4 oz	\$9.95	\$10.53	\$11.70





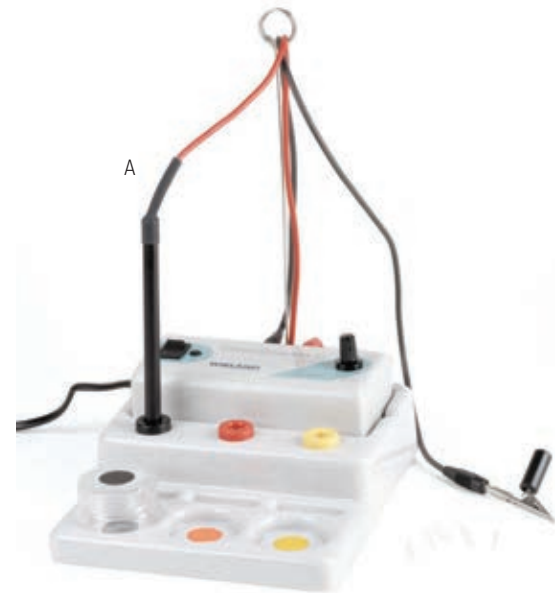

**RHODINETTE PEN PLATER REPLACEMENT PARTS**

Fiber-electrode plating unit for spot and surface plating. Achieve reliable and consistent results each time. The efficient design allows for multiple pen plating options. Holds up to three pens and three plating solutions (not included). Instructions included. Made in Germany.

Includes:

- Rectifier unit with stand
- Five regular fiber tips
- Red anode pen with fiber tip
- One glass container
- Black lead wire with clip

Item	Order #	Description	12+	6+	1+
A	45-4050	Rhodnette Pen Plater	–	–	\$600.00
B	45-4052	Red Anode Pen with Fiber Tip	\$201.75	\$213.62	\$237.35
C	45-4053	Black Lead Wire with Clip	\$37.78	\$40.01	\$44.45
D	45-4054	Black Glass Container	\$16.70	\$17.42	\$18.15
E	45-4055	Red Glass Container	\$16.70	\$17.42	\$18.15
F	45-4056	Yellow Glass Container	\$16.70	\$17.42	\$18.15
G	45-4057	Regular Fiber Tips (Pack of 5)	\$1.98	\$2.06	\$2.15
H	45-4058	Fine-Point Fiber Tips (Pack of 3)	\$2.12	\$2.21	\$2.30

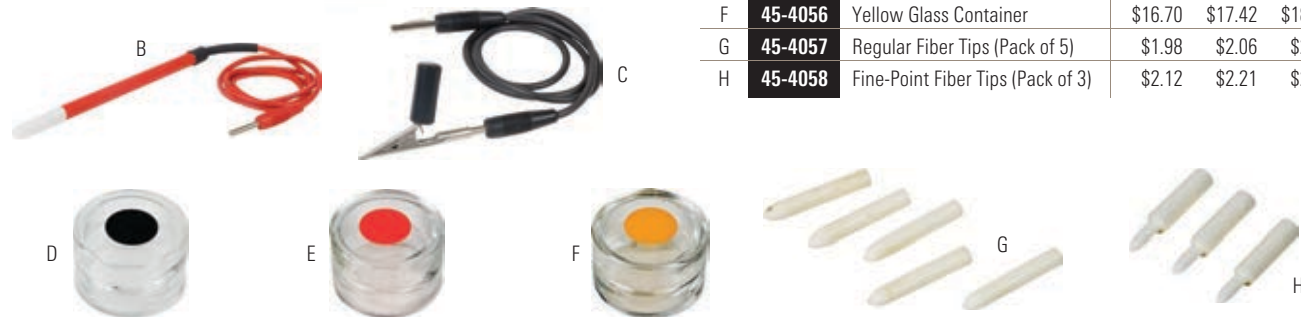

**COMPACT PEN PLATER**

This compact pen plater does an excellent job and will fill the void for the occasional user of a pen plater. The compact pen plater includes the plating unit, power supply, grounding wire, clip, pen with 1/8" tip, and instructions.

Order #	Description	12+	6+	1+
45-4040	Compact Pen Plater	\$48.62	\$51.48	\$57.20



**PLATEMATE DISPOSABLE PEN PLATER**

This is the easiest pen plater to use for gold or rhodium. It is small and lightweight so it can be used virtually anywhere. No need for a rectifier, the power source is a battery. Just add your gold or rhodium pen plating solution and you are ready to plate. Each pen will plate up to 90 minutes of continuous plating.

Order #	Description	12+	6+	1+
45-4100	Disposable Pen Plater	\$22.48	\$23.81	\$26.45



**THE WIZARD® DISPOSABLE PEN PLATER**

The next generation disposable pen plater is here. A sleek, ergonomic, stainless steel body and easily replaceable tips provide six volts capacity with no knobs to adjust. This battery-operated, completely portable pen plater is great for touch ups and will run for up to an hour of continuous plating.

Order #	Description	12+	6+	1+
45-4070	Wizard Disposable Pen Plater	\$50.15	\$53.10	\$59.00



Find added video content on [Stuller.com/VideoCenter](http://Stuller.com/VideoCenter).

**DELUXE PLATING PEN**

Easy-to-hold pen with titanium head allows platinum plating with improved conductivity for the tip. Flexible wire conductor and insulation on the 36-inch leads. These characteristics make for easy plating in hard-to-reach areas, development of graphics and designs, touch ups, repairs, and more requires rectifier.

- Replaceable tip
- Positive contact pin connector fastens securely with the power source.
- Protective cap over the tip for storage.

Order #	Description	12+	6+	1+
45-4069	Deluxe Plating Pen	\$75.65	\$80.10	\$89.00



**MEDIUM BULLET FELT TIP**

Replacement fine- point fiber tips.

Item	Order #	Description	12+	6+	1+
A	45-4058	Fine	\$3.28	\$3.69	\$4.10
B	45-4057	White Felt Bullet Tips (Pack of 10)	\$3.28	\$3.69	\$4.10
C	45-4059	Brown	\$3.31	\$3.46	\$3.60

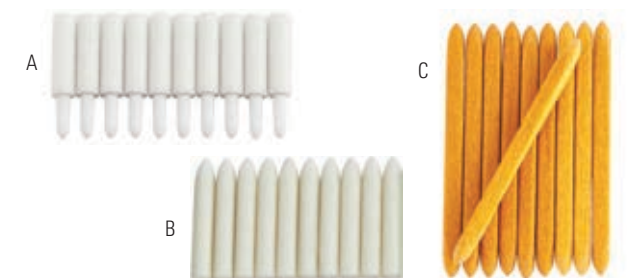

**SAMSON PEN PLATER**

Heavy-duty, high-quality pen platers built for day-in, day-out use. These two amp pen platers employ the latest in technology for dependable results. Available in three models. One-year factory warranty. Made in the USA.

Order # 45-40000

Item	Description	12+	6+	1+
H	Economy Pen Plater	\$101.66	\$107.64	\$119.60
J	Standard Pen Plater	\$169.96	\$179.96	\$199.95
K	Deluxe Pen Plater	\$237.83	\$251.82	\$279.80

Order # 45-40050

REPLACEMENT PARTS

Item	Description	12+	6+	1+
L	Red Pen with 1/16" Male Fiber	\$36.38	\$38.52	\$42.80
	Red pen with 1/16" Fiber Tip	\$36.93	\$39.11	\$43.45
M	Black Lead with Clip	\$16.11	\$17.06	\$18.95
N	Jar	\$4.55	\$4.82	\$5.35

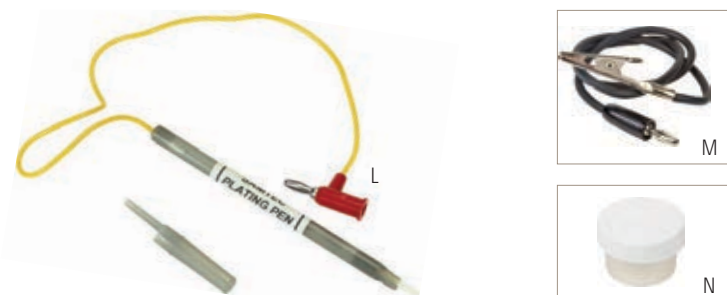



**RHODIUM PLATING SOLUTION**

Super Bright-white rhodium for plating. No mixing required, this ready-to-use, concentrated formula produces bright-white finish, which reduces tarnish. Acid based with Approximate eight to nine-month shelf life, prices will fluctuate according to rhodium market. Hazardous material must ship UPS Ground.

Item	Order #	Plating	Rhodium Volume	Container Volume	1+
A	45-4142	Bath	1 gram	1 pint	Call for pricing
B	45-4143	Bath	2 gram	1 pint	Call for pricing
C	45-4141	Bath	½ gram	½ pint	Call for pricing
D	45-4147	Pen	1 gram	25 ml	Call for pricing
E	45-4140	Pen	½ gram	25 ml	Call for pricing
F	45-4145	Pen	¼ gram	1 oz	Call for pricing
G	45-4154	Pen	1 gram	50 ml	Call for pricing
H	45-4146	Pen	½ gram	125 ml	Call for pricing



**RHODIUM BATH KIT CONCENTRATE**

Concentrate for bath plating is perfect for all of your rhodium plating needs. Follow mixing instructions. Prices will fluctuate according to rhodium market.

Item	Order #	Rhodium Volume	Container Volume	1+
J	45-4152	½ gram	½ pint	Call for pricing
K	45-4153	1 gram	½ pint	Call for pricing



**SUPER BLACK RHODIUM PLATING SOLUTION**

Black rhodium plating solution provides a long-lasting, tarnish-resistant gray-black finish. Use with a platinized titanium anode or carbon anode. Prices will fluctuate according to the rhodium market. This item may apply hazardous charges to shipping depending on the total weight of the order which will affect the final hazardous shipping charges.

Item	Order #	Plating	Rhodium Volume	Container Volume	1+
L	45-4148	Pen	¼ gram	1 oz	Call for pricing
M	45-4149	Pen	½ gram	25 ml	Call for pricing
N	45-4150	Bath	1 gram	1 pint	Call for pricing



Find added video content on [Stuller.com/VideoCenter](https://www.stuller.com/VideoCenter).

**LEGOR GOLD FLASH BATH PLATING SOLUTION**

The GF gold plating series has been designed for flash plating of up to 0.2 microns. The series is cyanide free and ready-to-use. Pink bath plating is a ready-to-use Red gold flash plating bath. The main features of this electrolyte are as follows:

- Cyanide free flash gold plating
- Working temperature: 50-60c
- Good penetrating power, and good distribution.

Order #	Description	Size	1+
45-2233	Pink Bath Plating	1 gram	Call for pricing

**LEGOR ULTRABRIGHT RHODIUM PLATING SOLUTION**

Ultrabright Rhodium is a ready-to-use anti-burn rhodium plating bath with exceptional features. The properties of the deposit and its degree of whiteness make this plating bath a point of reference for the worldwide market. The higher degree of whiteness is due to a more compact deposition with respect to those achieved with the other white rhodium solutions in the market. As a result, a higher white will be achieved at the same working time. The main features of this electrolyte are as follows:

**Order # 45-2230**

Item	Description	Rhodium Volume	1+
A	Ultrabright Bath Plating, 500ml	1 g	Call for pricing
B	Ultrabright Bath Plating, 1L	2 g	Call for pricing



Find added video content on [Stuller.com/VideoCenter](https://www.stuller.com/VideoCenter).

- Flash rhodium-plating until 0.5 microns
- Exceptional brilliant white deposits
- Wider plating range of voltage and amperage
- Possible to use at room temperature
- Good distribution and penetration power
- Exceptional coverage and deposition speed



**LEGOR BLUE RHODIUM PLATING SOLUTION**

Ultrabright Blue Rhodium is a galvanic solution containing two grams of Rh/500 ml of ready-to-use solution for blue rhodium decoration by immersion. RH2BLUE has been specifically developed for decorative application on the surface of precious metals and small non-ferrous items. The main characteristics of this electrolyte are

Item	Order #	Description	Rhodium Volume	1+
C	45-2231	Ultrabright Blue Rhodium, 500ml	2 g	Call for pricing



Find added video content on [Stuller.com/VideoCenter](https://www.stuller.com/VideoCenter).

- Extremely brilliant blue deposits
- Can be used at room temperature.



**LEGOR GOLD THICKNESS BATH PLATING SOLUTION**

The GT Gold Plating Series is composed of weak acidic solutions designed to achieve thickness of up to two microns. GT solutions present the perfect ready-to-use answer to manufacturers who are looking to obtain a solid gold layer of metallic surfaces. The GT series products allow you to obtain hard, brilliant gold depositions of 22.5-24 karat, with an excellent wear and corrosion resistance, and the following characteristics:

**Order # 45-2232**

Item	Description	Rhodium Volume	1+
D	14K Bath Plating Solution, 1L	2 g	Call for pricing
E	24K Bath Plating Solution, 1L	2 g	Call for pricing

- Perfect functioning even at low gold concentration
- Wide current flow range
- Excellent distribution
- Low density gold deposits
- Easy to control and to maintain
- Calibrated to meet the new EU low-nickel-release laws (UNI EN 1811:2011)



**LEGOR BLUE RHODIUM PEN PLATING SOLUTION**

Blue rhodium is a perfect option to add color to metallic surfaces while maintaining the precious aspect of the design. Most commonly used for plating the prong area and enhancing the color of blue stones, this room-temperature procedure makes it ideal for two-tone designs. The newly developed formula has proven to be one of the most stable on the market today.

**Order # 45-2234**

Item	Description	1+
F	Blue Rhodium Pen Plating, 50ml	Call for pricing
G	Blue Rhodium Pen Plating, 100ml	Call for pricing
H	Blue Rhodium Pen Plating, 25ml	Call for pricing



Find added video content on [Stuller.com/VideoCenter](https://www.stuller.com/VideoCenter).







**CLEAN EARTH PLATING SOLUTIONS**

All Clean Earth plating solutions are cyanide-free. They are ecologically safer than standard plating solutions yet plate uniformly and produce a hard, durable finish. Used in bath plating.

Order # 45-20600

Item	Description	Container Volume	1+
A	Nickel-Free	4 quarts	\$44.30
B	Nickel Mirror	4 quarts	\$38.60
C	Silver-Free	4 quarts	\$101.00
D	Copper Primer	4 quarts	\$34.10
E	Copper Mirror	4 quarts	\$34.10
F	Black-Free	4 quarts	\$39.75

**CLEAN EARTH PLATING SOLUTIONS**

All Clean Earth plating solutions are cyanide-free. They are ecologically safer than standard plating solutions yet plate uniformly and produce a hard, durable finish. Produces a uniform gold color. Use with a stainless steel or pure gold anode. Plate with the solution heated to 140°F (60°C) at 3-4 volts for 30-45 seconds. A change in the plating time will affect the color. Used in bath plating.

Order # 45-21200

Item	Description	Container Volume	1+
G	14K Gold	1 quart	\$212.15
H	18K Gold	1 quart	\$212.15
J	24K Gold	1 quart	\$212.15

**CLEAN EARTH PEN PLATING**

Clean Earth is a resilient gold plating solution that deposits a flash plate of gold over nickel, sterling silver, gold, rhodium, and most other similar metals. Cyanide-free.

Order # 45-25000

Item	Description	Container Volume	1+
K	14K Gold	1 fluid ounce	\$95.35
L	18K Gold	1 fluid ounce	\$95.35
M	24K Gold	1 fluid ounce	\$95.35
N	24K Rose Gold	1 fluid ounce	\$95.35



Pricing on plating solutions containing precious metals will fluctuate with the metal market.

**CLEAN EARTH™**

**Gold Plating** Produces a uniform gold color. Use with stainless steel or pure gold anode. Plate with the solution heated to 140°F (60°C) at 3-4 volts for 30-45 seconds. Changing the plating time or solution temperature will affect the color.

**Silver** Produces a uniform silver plate. Use with stainless steel or pure silver anode. Plate with the solution at room temperature at 1.4-1.8 volts for 15-90 seconds. The finish will reflect the surface of the underplate; shiny silver over shiny metals and matte silver over a dull surface.

**Nickel Mirror** Adds a decorative brilliance and a white mirror shine to dull finishes. Best if used over Copper Mirror. An excellent base for rhodium, gold, or silver plating. Use with pure nickel anode. Plate with solution at 140°F (60°C) at 2-4 volts for 2-10 minutes.

**Nickel-Free** A nickel-free alloy similar in color to nickel. Best if used over Copper Mirror. An excellent base for gold and silver plating. Use with nickel anode. Plate with solution 140°F (60°C) at 2-4 volts for 30-90 seconds.

**Copper Primer** Used as a pre-plate to cover difficult to plate metals such as tin, lead, and zinc, die-cast metals. A excellent base for nickel plating. Use with a pure copper anode. Plate with solution at 130°F (54°C) at 1-2 volts for 2-5 minutes.

**Copper Mirror** Produces a bright copper finish. Air bubble agitation produces superior uniformity and shine. Use with a pure copper anode. Plate with solution at room temperature at 2-3 volts for 2-10 minutes. Electroform at 1-1.3 volts for 30 minutes to 5 hours.

**White-Free** Deposits a beautiful bright, white finish. Best if used over Nickel Mirror or Copper Mirror. Use a stainless steel anode. Plate with a solution at room temperature at 2-4 volts for 30-60 seconds.

**Black-Free** Use to achieve an antique finish. After article is plated with Black-Free, highlights are relieved by polishing. Use with a stainless steel anode. Plate with solution at 120°F (50°C) at 3-6 volts for 30-90 seconds.

**RHODIUM TESTER**

Quickly and easily test your rhodium plating solution. Know precisely when to add rhodium replenisher.

Order #	Description	12+	6+	1+
56-7607	Rhodium Tester	\$103.62	\$109.71	\$121.90



**RHODIUM CARBON TREATMENT KIT**

Excellent for removing organic impurities that cause rhodium plating problems. Easy-to-follow instructions to ensure effective use.

Item	Order #	Description	12+	6+	1+
A	45-4160	Carbon Treatment Kit	\$77.65	\$81.02	\$84.40

REPLACEMENT PARTS

B	45-4162	Activated Carbon Treatment	\$13.43	\$14.02	\$14.60
B	45-4163	Filter Paper 40 cm (10 Sheets)	\$16.24	\$16.94	\$17.65



**EAR POST PROTECTORS**

Silicon rubber sleeves to protect ear posts when plating, tumbling, or setting. Excellent for use on surgical steel, gold-filled, karat gold, and sterling silver posts.

Order # 45-05000

Description	Length	12+	6+	1+
Earring Post Protectors	½"	\$3.49	\$3.69	\$4.10
Earring Post Protectors	⅝"	\$4.08	\$4.32	\$4.80

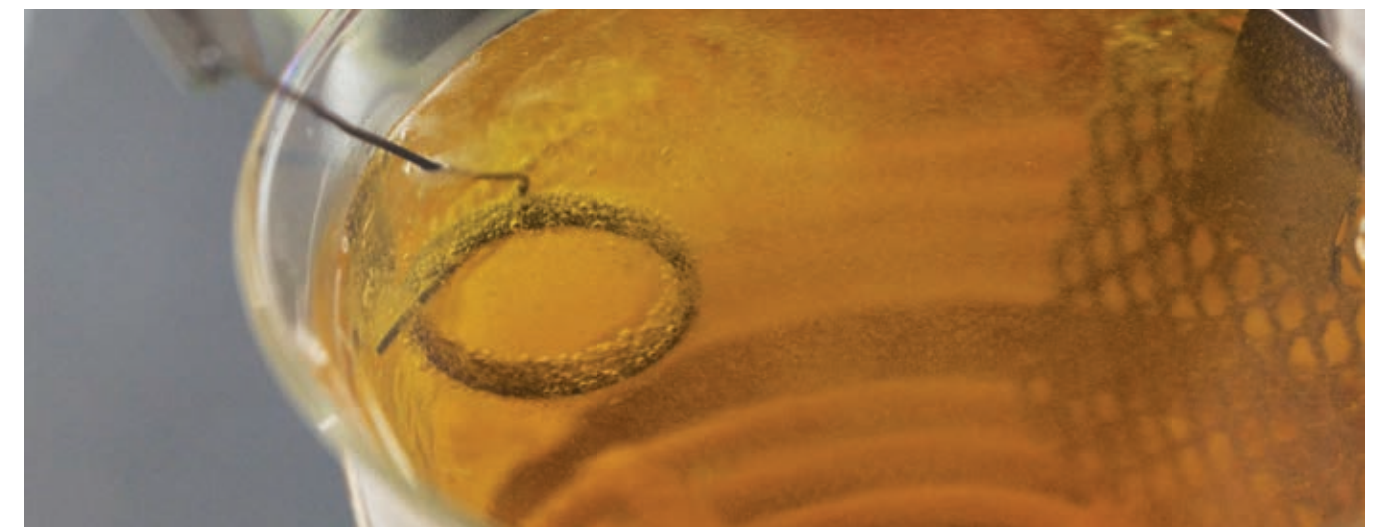



**CLEAN EARTH ELECTROCLEANER**

A quick and effective method of cleaning objects prior to plating. The cleaning process uses an electrolytic bath, similar to plating operations. (The two-pound size makes eight gallons; five-pound size makes 20 gallons.) Use with a stainless steel anode. Clean with the solution heated from 120°-160°F (50°-71°C) at 2-6 volts for 15-30 seconds.

Order # 45-20200

Item	Size	12+	6+	1+
A	2 lb container (makes 8 gallons)	\$18.23	\$19.31	\$21.45
B	5 lb container (makes 20 gallons)	\$39.70	\$41.42	\$43.15



**CLEAN EARTH STRIP-FREE**

Use to strip gold plating. Reverse plate with the solution heated to 130°-150°F (50°-65°C) at 3-6 volts for 30-90 seconds. Use with a stainless steel anode.

Order #	Size	12+	6+	1+
45-2180	1 quart	\$19.87	\$20.74	\$21.60



**CLEAN EARTH ACTIVATOR**

This powdered acid is mixed with water to produce a mild solution for etching, brightening, and cleaning. Use to clean and activate parts to assure strong metallic bonding throughout the subsequent plating process. Use at room temperature for 30-60 seconds. Excellent results for rhodium plating when used after electrocleaning step and before rhodium bath. *Note: This solution is not used with a rectifier.*

Order #	Size	12+	6+	1+
45-2040	2 lb	\$18.49	\$19.30	\$20.10



**CLEAN EARTH STAINLESS STEEL ACID ACTIVATOR**

Clean Earth Stainless Steel Acid Activator is a powerful activator that provides excellent oxide removal and etching properties to help metals plate onto stainless steel. Clean Earth Stainless Steel Acid Activator offers a low cost, easily maintainable and ecological alternative to hazardous and noxious acids. This activator is designed to activate stainless steel for gold plating with Clean Earth Gold Plating Solution, for complete cyanide-free process.

Order #	Size	12+	6+	1+
45-2010	1 quart	\$70.72	\$76.68	\$85.20



**STULLER-GLO CYANIDE-FREE PEN PLATING SOLUTION**

This unique Stuller-Glo pen plating solution deposits beautiful gold colors easily and is a fully cyanide-free, ecological solution. Packaged in double walled jars with a wide base to help prevent spills. Non-poisonous, cyanide-free chemicals mean it does not incur the higher shipping charges that other hazardous materials do. A one-ounce bottle can generally cover approximately 1,000 square inches. Works with all pen platers.

Order # 41-41500

Description	Size	1+
14K Pen Plating Solution	1 oz	\$52.25
18K Pen Plating Solution	1 oz	\$52.25
24K Pen Plating Solution	1 oz	\$52.25
Rose Pen Plating Solution	1 oz	\$52.25



**ACID NEUTRALIZER**

Stops the pickling process when applied directly to an object. It will also neutralize pickling solutions.

Order #	Size	12+	6+	1+
54-5005	6 oz	\$4.09	\$4.27	\$4.45



**PALLADIUM PLATING SOLUTION**

Easy-to-use, cyanide-free, and ecologically friendly, this tarnish-resistant bright white palladium bath provides uniform plating from start to finish. This product produces a consistent bright white mirror finish. It can be used as an intermediate layer over gold, silver, palladium, and platinum, as well as a final plate over low-end jewelry. Non-hazardous shipping.

Order #	Rhodium Volume	Size	1+
45-4179	2½ gram	1 quart	Call for pricing



**ELECTRO CLEANER**

A quick and effective method of cleaning objects prior to plating. The cleaning process uses an electrolytic bath, similar to plating operations. Clean with the solution heated from 120°-160°F (50°-71°C) at 2-6 volts at 15-30 seconds. Use with a stainless steel anode.

Order #	Size	12+	6+	1+
45-0312	1 quart	\$10.72	\$11.18	\$11.65



**STOP-OFF BLUE**

A very effective solution that may be used to mask areas that do not need to be plated. May be cleaned after use with acetone. Use with a red sable brush.

Order #	Description	12+	6+	1+
45-4155	Stop-Off Blue	\$17.14	\$18.59	\$20.65

**SILVER BLACK**

This acid-based oxidizer produces an instantaneous deep black patina on silver, gold, copper, or bronze.

Order # 54-50300

Item	Size	12+	6+	1+
A	1 oz	\$3.82	\$3.98	\$4.15
B	4 oz	\$7.77	\$8.11	\$8.45
C	16 oz	\$22.19	\$23.49	\$26.10

**LIVER OF SULPHUR**

The most effective oxidizer for silver. This product is used to permanently "antique" silver and copper. It will not rub off or disappear during ultrasonic or steam cleaning. This product is NOT suitable for antiquing gold.

Order # 45-50000

Item	Description	Size	12+	6+	1+
D	Pro-Craft™ Lump Form	8 oz	\$16.70	\$17.42	\$18.15
E	Griffith	4 oz	\$10.81	\$11.28	\$11.75
F	Griffith	8 oz	\$18.49	\$19.30	\$20.10

**GROBET USA® LACQUER AND LACQUER STRIPPER**

Lacquer protects metal surfaces from scratches and tarnish. To remove lacquer from metal surfaces to lacquer stripper, which can also be used to thin lacquer.

Order # 45-79900

Item	Description	Size	12+	6+	1+
G	Lacquer	8 oz	\$14.21	\$14.83	\$15.45
H	Lacquer Stripper	8 oz	\$10.35	\$10.80	\$11.25

**DENATURED ALCOHOL**

For use in alcohol lamps, making anti-oxidizers, and as a quick-drying dip to prevent spotting of plated pieces. Flammable. Ships UPS Ground only.

Order # 54-80410

Item	Size	12+	6+	1+
J	16 oz	\$6.85	\$7.15	\$7.45
K	32 oz	\$8.83	\$9.22	\$9.60
L	1 gallon	\$28.11	\$29.33	\$30.55

**XL GEL SOLUTION**

Liver of Sulphur XL Gel is formulated for extended shelf life, versatility, and convenience. XL gel is used to patina metals, such as silver, copper, bronze, etc. Its shelf life is many times that of dry liver of sulphur and is non-flammable. Easy-to-use squeeze bottles.

Order # 45-49970

Item	Size	12+	6+	1+
M	1 oz	\$7.41	\$7.73	\$8.05
N	2 oz	\$11.50	\$12.00	\$12.50

**ANTIQUING SOLUTION**

Provides a dark, matte, antique finish to class rings or any other jewelry. Adheres to metal and dries in minutes. High spots can be wiped clean with Aul Solvent (removes background color) and a lint-free cloth. The background solution is resistant to wear and needs no lacquer.

Order # 45-01300

Item	Description	Size	12+	6+	1+
P	Antique Black	2 oz	\$11.59	\$12.10	\$12.60
Q	Aul Solvent	2 oz	\$10.49	\$10.94	\$11.40







A



B



C



D



E

**CERAMIT**

This two-part, liquid system produces a ceramic-like surface imitating kiln-fired enamels in appearance and physical properties. Low temperature curing-200°F (93.3°C) for one hour. Catalyst and color are mixed in a two to one proportion. Brush on, spray on, or apply with a spatula or squeeze bottle. Can be applied in a single coat or successive layers to obtain elegant finishes. Fourteen colors are available, which can be mixed to obtain an infinite variety of shades. Adheres to metals, wood, plastics, and ceramics. Can also be stoned and polished. Hardness of 60-75 on the Sward scale (as compared to kiln-fired enamel 65-80 that requires 1,500°F (815.6°C) to cure). Can be cured in ordinary kitchen ovens, by infrared lamps, or forced air blowers.

Item	Order #	Description	Color	Container Volume	12+	6+	1+
A	45-80000	Ceromit Kit			\$70.89	\$73.97	\$77.05
B	45-80000	Ceromit Thinner		1 pint	\$26.13	\$27.26	\$28.40

**CATALYST REFILLS**

C	45-88000	Refill		8 oz	\$15.41	\$16.08	\$16.75
D	45-80000	Refill		1 pint	\$29.58	\$30.86	\$32.15
E	45-80000	Refill		1 quart	\$42.18	\$44.02	\$45.85

**REPLACEMENT COLORS**

F	45-80010	Opaque	Black	2 oz	\$7.73	\$8.06	\$8.40
G	45-80010	Opaque	White	2 oz	\$7.73	\$8.06	\$8.40
H	45-80010	Opaque	Red	2 oz	\$7.73	\$8.06	\$8.40
J	45-80010	Opaque	Orange	2 oz	\$7.73	\$8.06	\$8.40
K	45-80010	Opaque	Yellow	2 oz	\$7.73	\$8.06	\$8.40
L	45-80010	Opaque	Jade	2 oz	\$7.73	\$8.06	\$8.40
M	45-80010	Opaque	Turquoise	2 oz	\$7.73	\$8.06	\$8.40
N	45-80010	Transparent	Red (Translucent)	2 oz	\$7.73	\$8.06	\$8.40
P	45-80010	Transparent	Brown	2 oz	\$7.73	\$8.06	\$8.40
Q	45-80010	Transparent	Yellow (Translucent)	2 oz	\$7.73	\$8.06	\$8.40
R	45-80010	Transparent	Green (Translucent)	2 oz	\$7.73	\$8.06	\$8.40
S	45-80010	Transparent	Blue (Translucent)	2 oz	\$7.73	\$8.06	\$8.40
T	45-80010	Transparent	Clear	2 oz	\$7.73	\$8.06	\$8.40
U	45-80010	Fluorescent	Red (Fluorescent)	2 oz	\$7.14	\$7.56	\$8.40
V	45-80010	Fluorescent	Green (Fluorescent)	2 oz	\$7.14	\$7.56	\$8.40
W	45-80010	Fluorescent	Blue (Fluorescent)	2 oz	\$7.14	\$7.56	\$8.40

Individual 2 oz. bottles can be ordered by product numbers listed with colors.

**Opaque Colors:**



**Transparent Colors:**

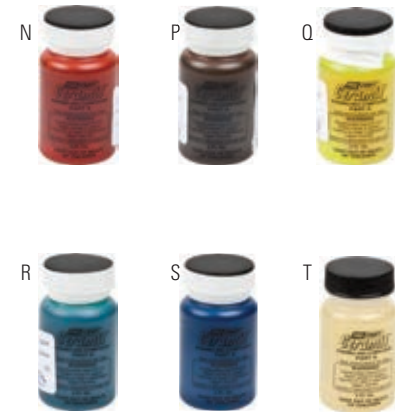

**Fluorescent Colors:**



**U-NAMEL**

A new method of enameling utilizing fast curing ultraviolet sensitive material.

**ADVANTAGES:**

- Scratch, wear and shock resistant surface
- Does not chip, crack, flake, peel, or shrink
- Easy to drill, grind, polish, carve, sand, and turned at high speeds
- Sold in 7 gram jars which can be transferred into the supplied UV syringe for application on flat or curved surfaces, or used directly
- Easy-to-mix colors that won't fade

**USES:**

- Inlaid into precious or non-precious metal, glass, plastic, ceramic, enamel, or U-NAMEL
- Can be layered to make cabachons
- Can be used next to other U-NAMEL or mixed to make interesting designs



Starter Kit includes:

- Five to seven gram tubs in the following colors: black, white, red, blue and yellow
- Curing light
- Safety goggles
- Mixing pad
- Bond liquid
- Mixing/application tool
- Reusable syringe with five tips

**U-NAMEL UV CURED ENAMEL SYSTEM**

The U-NameL ultraviolet enamel application system cures in one to two minutes. Once cured the enamel becomes scratch and wear resistant. It will not chip, flake, peel, or shrink. The cured enamel is easily drilled, grinded, polished, carved, and sanded. The easy-to-mix colors won't fade and can be inlaid into metal, glass, plastic, and ceramic. The enamels will adhere to flat surfaces and can be layered to create cabochons. The kit includes five to seven-gram jars of enamel in popular colors, bonding primer, UV lamp, safety goggles, and syringe with tips. This product is non-hazardous.

Item	Order #	Description	12+	6+	1+
A	45-8060	UV Cured Enamel System	\$133.08	\$138.86	\$144.65

**ACCESSORIES**

B	45-80620	Bond Liquid	\$15.23	\$15.89	\$16.55
C	45-80620	Curing Light	\$28.47	\$29.71	\$30.95
D	45-80620	Mixing Pad	\$1.56	\$1.63	\$1.70
E	45-80620	Brushes	\$3.82	\$3.98	\$4.15
F	45-80620	Glasses	\$5.75	\$6.00	\$6.25
G	45-80620	Cloth	\$1.93	\$2.02	\$2.10
H	45-80620	Gloss Liquid	\$9.48	\$9.89	\$10.30

**REPLACEMENT COLORS**

	45-8061	Green	\$15.23	\$15.89	\$16.55
	45-8061	Black	\$15.23	\$15.89	\$16.55
	45-8061	Red	\$15.23	\$15.89	\$16.55
	45-8061	Yellow	\$15.23	\$15.89	\$16.55
	45-8061	Pearl	\$15.23	\$15.89	\$16.55
	45-8061	White	\$15.23	\$15.89	\$16.55
	45-8061	Blue	\$15.23	\$15.89	\$16.55



B



C



D



E



F



G



H



**DISPOSABLE LATEX GLOVES**

These high-grade, expandable latex gloves are thin to allow good finger sensitivity and excellent dexterity but are tough enough to protect your hands from dirt, grit, and harsh chemicals. Excellent to use during buffing or polishing. Gloves fit either hand.

Order # 17-07450

100

Description	Size	12+	6+	1+
Disposable Latex Gloves	Small	\$13.89	\$14.50	\$15.10
Disposable Latex Gloves	Medium	\$13.89	\$14.50	\$15.10
Disposable Latex Gloves	Large	\$13.89	\$14.50	\$15.10

**POWDER-FREE BLUE NITRILE GLOVES**

Offer better tactile sensitivity, comfort, dexterity, and puncture resistant than rubber or vinyl. These powder-free gloves are made stronger through a process called fusion bonding, which integrates synthetic polymers into the material to create a multi-layer glove or enhanced protection. Measures 4.4 mil (palm) and 4.7 mil (fingers) thickness/9 1/2" length.

Order # 17-0846



Description	Size	12+	6+	1+
Blue Nitrile Gloves	Small	\$13.94	\$14.54	\$15.15
Blue Nitrile Gloves	Medium	\$13.94	\$14.54	\$15.15
Blue Nitrile Gloves	Large	\$13.94	\$14.54	\$15.15
Blue Nitrile Gloves	Extra-Large	\$13.94	\$14.54	\$15.15

**BLACK NITRILE GLOVES POWDER FREE**

Black nitrile is the ideal choice for mechanical jobs, auto work, and/or other applications where hands can end up covered in dirt and grime. Nitrile gloves offer better tactical sensitivity, comfort, dexterity, and puncture resistance than both rubber and vinyl. These powder-free gloves feature textured fingers and a beaded cuff. Box of 100.

Order # 17-0847

100



Description	Size	12+	6+	1+
Black Nitrile Gloves	Small	\$20.33	\$21.22	\$22.10
Black Nitrile Gloves	Medium	\$20.33	\$21.22	\$22.10

**NEOPRENE GLOVES**

Black neoprene 14" coated gloves with knit lining provide superior quality and durability as well as protection against acids, caustics, oils, greases, and many solvents. Excellent all-around protection for plating. One size fits all.

PAIR



Order #	Description	12+	6+	1+
22-7508	Neoprene Gloves	\$15.69	\$16.37	\$17.05



**NEOPRENE PLATING APRON**

Durable neoprene apron is designed to protect against chemical spills during plating and other applications.

Order #	Description	WxL	12+	6+	1+
47-3068	Apron	36" x 43"	\$18.58	\$19.39	\$20.20

**SAFETY GLASSES**

Engineered with an innovative molding process that actually allows the frame to serve as a shock absorber that can diffuse and deflect impact. A ventilation channel between the frame and brow bumper directs airflow under the lens to reduce moisture build-up and fogging. Three-position ratchet lens inclination system with adjustable length temples allows you a custom fit.

Item	Order #	Description	Lens Shade	Lens Color	12+	6+	1+
A	29-0012	Direct Safety® Kavalry	—	Clear	\$7.59	\$7.92	\$8.25
B	29-0010	Crews Blackjack	—	Clear	\$7.41	\$7.73	\$8.05
C	29-0058	UVEX Genesis	#5.0	Green	\$16.48	\$17.87	\$19.85





# PLIERS, CUTTERS, AND SHEARS



## LINDSTROM® 80 SERIES: TRIED AND TRUE PERFORMANCE FOR THE TRADITIONAL USER

Surpassed only by our own Lindstrom RX, the Lindstrom 80 series remains the top choice for the traditional user. This range of cutters offers unsurpassed cutting capacity covering a wide range of wire dimensions and types.

### 1% CARBON/CHROME BALL BEARING GRADE STEEL

Material usually reserved for high stress applications provides incredible impact resistance and resiliency with smoother, cleaner penetration at the cutting edge.

### FORGED COMPONENTS

Grain structure follows profile of the blank to maximize tool strength.

## CNC GRINDING OR FORGED BLANKS

Computer controlled machine grinding guarantees edge angle accuracy and contact which increases tool reliability and consistency.

## 63-65 HRC ON CUTTING EDGES

Precision induction hardening of 1% Carbon/Chrome Ball Bearing Steel allows high Rockwell hardness without brittleness resulting in a longer lasting tool.

## ESD SAFETY

All Lindstrom 80 Series are ESD safe. Resins with conductive additives in the handles create a material that safely dissipates electrostatic charges, reducing possibility of damage to sensitive components.



A



B



C



D



E



F



G



1% carbon/chrome ball bearing grade steel Material usually reserved for high stress applications provides incredible impact resistance and resiliency with smoother, cleaner penetration at the cutting edge.

## LINDSTROM® 80 SERIES YELLOW HANDLE CUTTERS

Advanced, diagonal-cutting nippers, screw-type precision, lap joint allows for optimum strength. Handles are dual spring-loaded, and oval jaw design allows ease of use. Made in Spain.

Order # 46-81400

Item	Description	Length	Jaw Capacity	Model #	1+
A	Small Oval Micro-Bevel	4 <sup>3</sup> / <sub>8</sub> "	3/8"	8140	\$50.00
B	Medium Micro-Bevel	4 <sup>1</sup> / <sub>2</sub> "	1/2"	8150	\$51.00
C	Small Pure Ultra-Flush	4 <sup>1</sup> / <sub>8</sub> "	3/8"	8142	\$55.00
D	Small Oval Flush	4 <sup>1</sup> / <sub>8</sub> "	3/8"	8141	\$53.00
E	Medium Ultra-Flush	4 <sup>1</sup> / <sub>2</sub> "	1/2"	8152	\$63.00
F	Large Oval Micro-Bevel	4 <sup>15</sup> / <sub>16</sub> "	5/8"	8160	\$57.00
G	Large Oval Ultra-Flush	4 <sup>15</sup> / <sub>16</sub> "	5/8"	8162	\$72.25



## LINDSTROM® SUPREME SERIES PLIERS

High-quality, extremely precise and accurate pliers. Specially forged box joint provides extra long contact surfaces. Joint moves smoothly for extra precision even at the tip. Box joint allows for smaller overall dimensions, improving accessibility in confined areas. With dual spring-loaded handles and comfortable cushion grips marked with information on pliers' capacity. Made in Spain.

Order # 46-71900

Item	Description	Length	Jaw Capacity	Model #	1+
A	Side Cutter	4 <sup>1</sup> / <sub>4</sub> "	1 <sup>1</sup> / <sub>2</sub> "	7190	\$50.00
B	Flat Nose	4 <sup>3</sup> / <sub>4</sub> "	2 <sup>5</sup> / <sub>32</sub> "	7490	\$47.00
C	Round Nose	4 <sup>3</sup> / <sub>4</sub> "	2 <sup>5</sup> / <sub>32</sub> "	7590	\$45.00
D	Flush Oblique End Cutter	4 <sup>1</sup> / <sub>4</sub> "	1 <sup>9</sup> / <sub>32</sub> "	7291	\$58.00
E	Short Chain Nose	4 <sup>3</sup> / <sub>4</sub> "	2 <sup>5</sup> / <sub>32</sub> "	7893	\$45.00
F	Long Chain	5 <sup>1</sup> / <sub>4</sub> "	1 <sup>1</sup> / <sub>4</sub> "	7890	\$49.95
G	Curved Nose	5"	1 <sup>1</sup> / <sub>8</sub> "	7892	\$50.00

## Pliers, Cutters and Shears



A



B



C



D



E



F



G

## LINDSTROM® NOSE PLIERS

The Lindstrom round-flat nose pliers are precision-crafted in Spain from hardened, high-chromium steel alloy and precision-ground to exact specifications. They are ideal for heavy-gauge metals and harder metals.

Order # 46-79000

Item	Description	Length	Model	12+	6+	1+
H	Round-Flat Nose	7"	7450EX	\$50.15	\$53.10	\$59.00
J	Chain Nose	7"	7893EX	\$48.45	\$51.30	\$57.00



H



J

## TRX 8180 LINDSTROM® CUTTER

Use on copper wire and hard wire applications. Handles solid copper wire and hard steel wire from 24 gauge -0.5 mm/0.02 inch- up to 9 gauge - 2.75 mm/0.11 inch. This powerhouse cutter utilizes the new progressive cut beveled edges- suited for soft wire at the tip and hard wire closer to the jaw—for versatile operation. Micro-bevel cutting edges hardened to 63-65 for durable performance.

Order #	Length	12+	6+	1+
46-8164	8"	\$56.10	\$59.40	\$66.00



## LINDSTROM® MULTIPURPOSE SHEAR

Ergonomic, cushion grip handles. Blades with a 57-59 Rockwell Hardness for long life. These Lindstrom shears cut easily through 28 gauge silver stock.

Order #	Length	12+	6+	1+
46-8163	5 <sup>3</sup> / <sub>4</sub> "	\$24.06	\$25.47	\$28.30



All items are priced at jeweler's cost, are sold each, unless otherwise noted, and are subject to change without notice. Visit [Stuller.com](http://Stuller.com) for our complete product selections, current pricing, and quantity price breaks. | 435



### TRONEX® PRECISION PLIERS

- Bearing ring lap-joint design insures superior performance to other pliers made with only rivet joints or box joints
- Cushion grips (ESD safe) with stainless steel leaf springs
- Choice of standard handle length or long ergonomic handle length
- Polished, hand-crafted finish, entirely free of burrs or sharp edges
- 100% quality assurance; each pair of pliers individually checked; one year factory guarantee
- Special design elements such as slightly rounded inner jaw edges and induction hardened tips
- Short jaw pliers have induction hardened tips
- Made in the USA

### THE LEADER IN CUTTING-EDGE TECHNOLOGY™

Tronex Tools is a company that places a strong emphasis on building solutions which support superior levels of cutting performance while providing customers with value and comfort. We call this combination of key qualities Cutting-Edge Technology™ and it remains one of our business' leading competitive advantages.

The success of Cutting-Edge Technology™ is built on three core components: unique hand cutter joint design, razor flush® edges, and exceptional and proprietary manufacturing techniques.

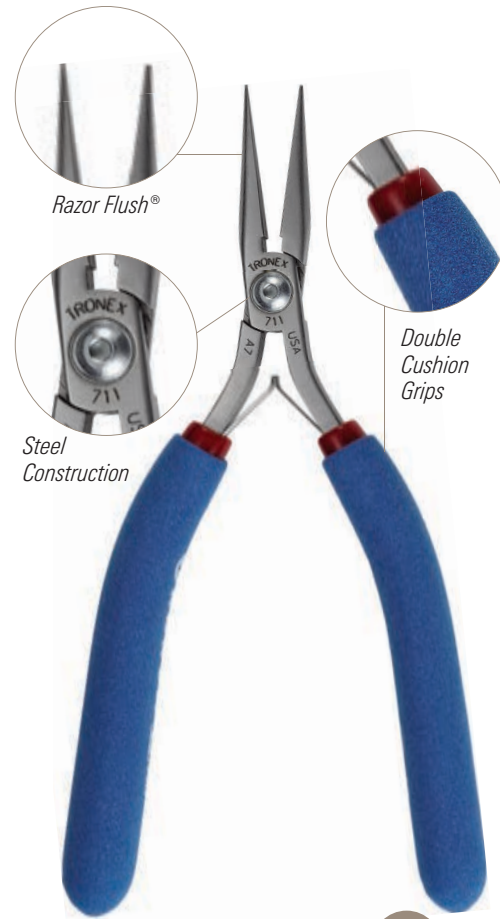

Find added video content on [Stuller.com/VideoCenter](http://Stuller.com/VideoCenter).

### TRONEX® PRECISION PLIERS

Order # 46-0010

Item	Description	Length	12+	6+	1+
A	Chain Nose - Smooth Jaw	6½"	\$40.25	\$42.62	\$47.35
B	Chain Nose - Short Smooth Jaw	6"	\$40.25	\$42.62	\$47.35
C	Needle Nose	6½"	\$33.70	\$35.69	\$39.65
D	Round Nose	6½"	\$40.25	\$42.62	\$47.35
E	Round Nose - Short Jaw	6"	\$40.25	\$42.62	\$47.35
F	Flat Nose - Step Tip	6½"	\$40.25	\$42.62	\$47.35
G	Flat Nose - Short Smooth Jaw	6"	\$40.25	\$42.62	\$47.35
H	Bent Nose	6"	\$41.18	\$43.61	\$48.45

### TRONEX® STANDARD HANDLE PLIERS

Order # 46-00100

Description	Length	12+	6+	1+
Chain Nose - Smooth Jaw	5½"	\$37.44	\$39.65	\$44.05
Chain Nose - Short Smooth Jaw	5"	\$37.44	\$39.65	\$44.05
Needle Nose	5½"	\$37.44	\$39.65	\$44.05
Needle Nose	5½"	\$37.44	\$39.65	\$44.05
Round Nose - Short Jaw	5"	\$37.44	\$39.65	\$44.05
Flat Nose - Smooth Jaw	5½"	\$39.31	\$41.63	\$46.25
Flat Nose - Short Smooth Jaw	5"	\$39.31	\$41.63	\$46.25
Bent Nose	5"	\$40.25	\$42.62	\$47.35

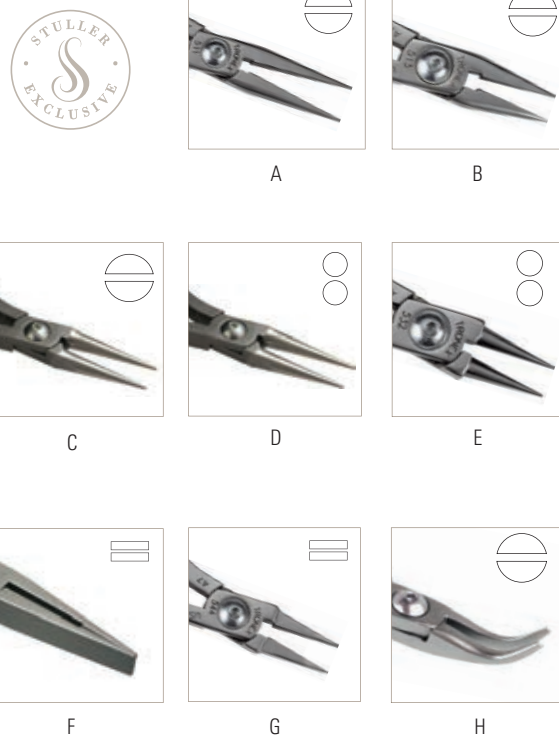

### TRONEX® HALF-ROUND/HALF FLAT NOSE PLIERS

Bearing ring lap-joint design that ensures superior performance to other pliers made with only rivet joints or box joints. Cushion grips (ESD safe) with stainless steel leaf springs. Choice of standard handle length or long ergonomic handle length. Polished, hand-crafted finish, entirely free of burrs or sharp edges. Enjoy 100% quality assurance. Each pair of pliers are individually checked and carry a one-year factory guarantee. Feature special design elements such as slightly rounded inner jaw edges and induction hardened tips. Short jaw pliers have induction hardened tips. Made in the USA.

Item	Order #	Description	Length	12+	6+	1+
A	46-0056	Half Round Half Flat Nose	7"	\$33.58	\$35.55	\$39.50
B	46-0055	Half Round Half Flat Nose	7"	\$32.13	\$34.02	\$37.80

### TRONEX® STANDARD HANDLE PLIERS

These flat nose pliers were developed specifically for our jewelry customers. The blades run flat the full length of the tool for grasping and bending along the entire blade. Because the tips are thinner, use caution when working with heavier gauge wire. Tip length is 1.25" (31.7mm).

Item	Order #	Description	Length	12+	6+	1+
C	46-0060	Flat Nose - Short, Wide Tips	5"	\$39.87	\$42.21	\$46.90
D	46-0061	Flat Nose - Short, Wide Tips	6"	\$41.61	\$44.06	\$48.95

### TRONEX® CUTTERS — OVAL AND TAPERED HEAD WITH LONG ERGONOMIC HANDLE

- Superior cutting performance, cutting edge hardness
- 100% quality assurance, each cutter individually checked; one year guarantee
- Unique lap joint design with matched bearing rings, Delrin® washer, extra sturdy nut, and finely pitched screw
- Cushion grips with choice of standard or long, ergonomic handle length
- Razor Flush® edges provide exceptional flush cuts
- Made in the USA

Item	Order #	Description	Length	12+	6+	1+
E	46-0027	Mini Taper Head	7"	\$43.99	\$46.58	\$51.75

### TRONEX® MINIATURE HIGH-RELIEF TIP CUTTER

Tip cutter features deep relief for an exceptionally low profile, short sturdy jaw, and Razor Flush® cutting edges.

Item	Order #	Description	12+	6+	1+
F	46-7905	Tip Cutter - Ergonomic Handle	\$69.81	\$73.92	\$82.13

### TRONEX® MINIATURE HIGH-RELIEF TIP CUTTER

Popular angulated cutter features a small cutting head with relief for excellent visibility, durability combined with fine cutting, and flush cutting edges.

Item	Order #	Description	12+	6+	1+
G	46-7903	Angulated Cutter Flush Cut	\$69.14	\$73.21	\$81.34

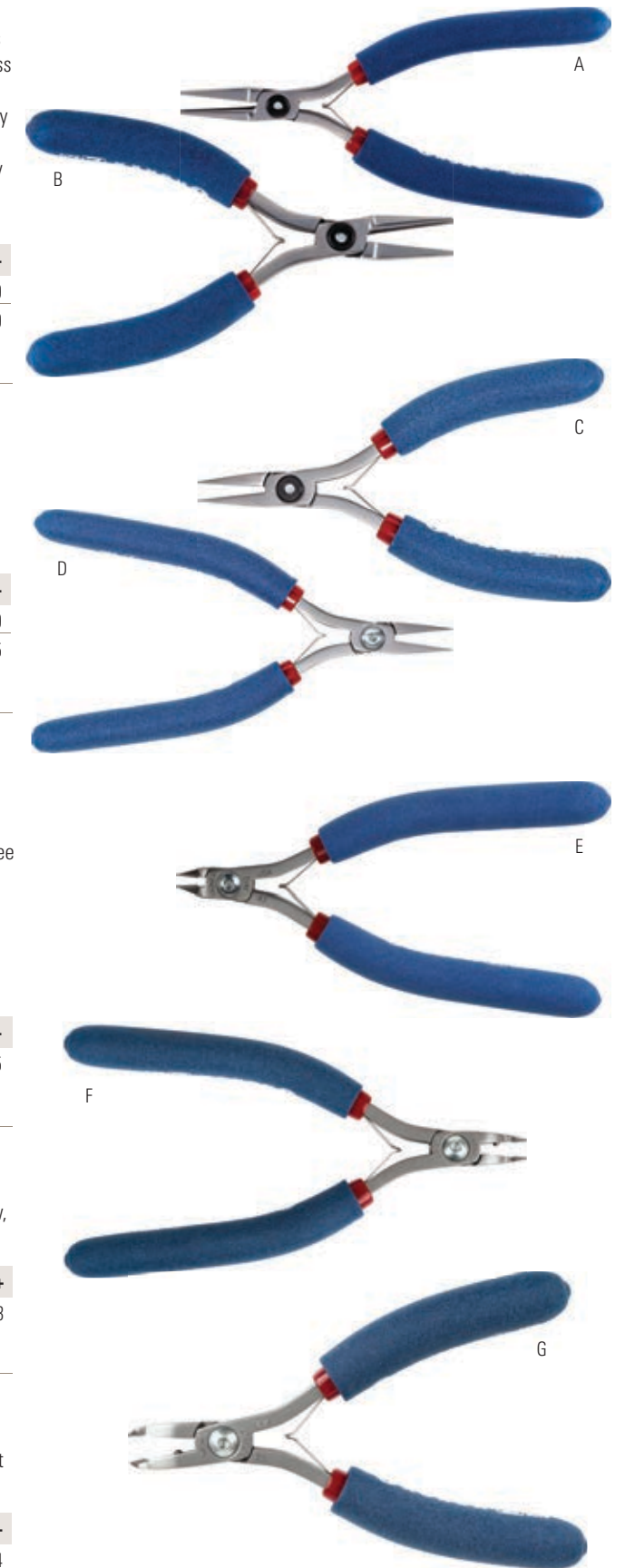





**TRONEX® CUTTERS**

- Superior cutting performance, cutting edge hardness
- 100% quality assurance, each cutter individually checked; one year guarantee
- Unique lap joint design with matched bearing rings, Delrin washer, extra sturdy nut, and fine-pitched screw
- Cushion grips with choice of standard or long, ergonomic handle length
- Razor Flush® edges provide exceptional flush cuts
- Made in the USA



**TRONEX® CUTTERS — OVAL AND TAPERED HEAD WITH LONG ERGONOMIC HANDLE**

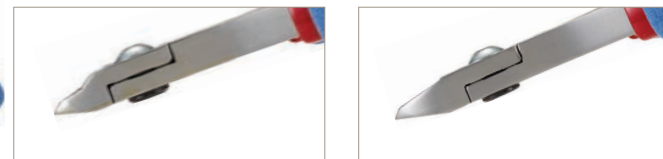

A

B

**Order # 46-00190**

Item	Description	Model #	Length	Cutting Edge	Cutting Capacity	12+	6+	1+
A	Mini Oval	7312	7"	Flush	38-16 AWG (01mm-1.25mm)	\$43.05	\$45.59	\$50.65
B	Large Oval	7512	7"	Flush	35-15 AWG (.15mm-1.5mm)	\$41.18	\$43.61	\$48.45



**TRONEX® OVAL CUTTERS — SEMI-FLUSH**

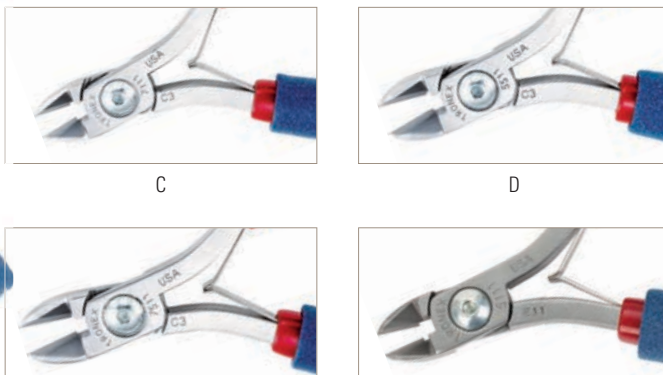

C

D

E

F

**Order # 46-78950**

Item	Description	Model #	Length	Cutting Edge	Cutting Capacity	12+	6+	1+
C	Long Oval	7111	7"	Semi Flush	32-16 AWG (.2mm-1.25mm)	\$43.14	\$45.68	\$50.75
D	Large Oval	5511	5"	Semi Flush	32-15 AWG (.2mm-1.5mm)	\$43.86	\$46.44	\$51.60
E	Large Oval	7511	7"	Semi Flush	32-15 AWG (.2mm-1.5mm)	\$45.48	\$48.15	\$53.50
F	Standard Oval	5111	5"	Semi Flush	32-16 AWG (.2mm-1.25mm)	\$41.65	\$44.10	\$49.00



**TRONEX® CUTTERS — OVAL AND TAPERED HEAD WITH STANDARD ERGONOMIC HANDLE**



A B



C D

**Order # 46-00350**

Item	Description	Model #	Length	Cutting Edge	Cutting Capacity	12+	6+	1+
A	Mini Oval	5312	5"	Flush	38-16 AWG (.1mm-1.2mm)	\$41.18	\$43.61	\$48.45
B	Mini Oval	5313	5"	Razor Flush	38-20 AWG (.1mm-.08mm)	\$44.92	\$47.57	\$52.85
C	Large Oval	5513	5"	Razor Flush	38-16 AWG (.1m-1.3mm)	\$42.12	\$44.60	\$49.55
D	Large Oval	5512	5"	Flush	35-15 AWG (.15mm-1.5mm)	\$39.31	\$41.63	\$46.25
	Oval Head	5112	5"	Flush	35-16 AWG (.15mm-1.25mm)	\$37.44	\$39.65	\$44.05
	Oval Head	5113	5"	Razor Flush	38-18 AWG (.1mm-1mm)	\$41.18	\$43.61	\$48.45
	Large Oval Relief	5522	5"	Flush	35-15 AWG (.15mm-1.4mm)	\$41.18	\$43.61	\$48.45
	Large Oval Relief	5523	5"	Razor Flush	38-16 AWG (.1mm-1.2mm)	\$44.92	\$47.57	\$52.85



E F

G H

J K

L M

**Order # 46-00350**

Item	Description	Model #	Length	Cutting Edge	Cutting Capacity	12+	6+	1+
E	Mini Taper Head	5412	5"	Flush	38-16 AWG (01mm-1.25mm)	\$41.18	\$43.61	\$48.45
F	Mini Taper Head	5413	5"	Razor Flush	38-20 AWG (.1mm-.08mm)	\$45.86	\$48.56	\$53.95
G	Taper Head	5212	5"	Flush	35-16 AWG (.15mm-1.25mm)	\$39.31	\$41.63	\$46.25
H	Taper Head	5213	5"	Razor Flush	38-18 AWG (.1mm-1mm)	\$43.05	\$45.59	\$50.65
J	Taper Relief	5222	5"	Flush	35-15 AWG (.1mm-1.2mm)	\$48.66	\$51.53	\$57.25
K	Taper Relief	5223	5"	Razor Flush	38-18 AWG (.1mm-.08mm)	\$55.25	\$58.50	\$65.00
L	Large Taper	5712	5"	Flush	35-16 AWG (.15mm-1.4mm)	\$42.12	\$44.60	\$49.55
M	Large Taper	5713	5"	Razor Flush	38-16 AWG (.1mm-1.2mm)	\$44.92	\$47.57	\$52.85

**TRONEX® CUTTERS — OVAL AND TAPERED HEAD WITH STANDARD ERGONOMIC HANDLE**

**Order # 46-00530**

Handle Type	Cutting Edge	Cutting Capacity	12+	6+	1+
Cushion Grip	Flush	38-16 AWG (.1mm-1.2mm)	\$42.12	\$44.60	\$49.55



All items are priced at jeweler's cost, are sold each, unless otherwise noted, and are subject to change without notice. Visit [Stuller.com](http://Stuller.com) for our complete product selections, current pricing, and quantity price breaks. | 439



**IDEAL-TEK**

The new handles on these cutters and pliers set a new benchmark in ergonomics. Following the user-centered design approach of one of the world's most respected research universities (University of Milan), over a two year period, Ideal-tek gained a full understanding of the needs, wants, and frustrations of end users. Subsequent painstaking attention to detail at every stage of the design process resulted in the creation of the ideal handles. Precision Swiss manufacture provides quality, accuracy, and longevity. The addition of Italian design brings beauty and elegance.

Ergo-tek. Perfect synergy.

**IDEAL-TEK PLIERS**

Ideal-Tek Swiss-made pliers feature a very fine tip and smooth or serrated jaws and inner edges. Features high-quality ball bearing steel (63 - 65 Rockwell Hardness [HRC]), pyrometer-controlled inductive hardening, two component ESD ergonomic handles with soft comfortable gripping surface, hard plastic core, dual leaf springs in blue steel, matched bearing rings, and friction lap joint with screw. The nut is made of hardened alloy steel in order to resist the high cutting load. The screw is finely pitched for perfect joint adjustment.

**Order # 46-70110**

Item	Description	Length	12+	6+	1+
A	Short Flat Nose	5¼"	\$34.51	\$36.54	\$40.60
B	Snipe Nose	5¼"	\$37.61	\$39.83	\$44.25
C	Snipe Nose Long	5½"	\$37.83	\$40.05	\$44.50
D	Round Nose	5¼"	\$36.98	\$39.15	\$43.50



**IDEAL-TEK CUTTERS**

Ideal-Tek Swiss-made cutters are very slim and are relieved to maximize accessibility. Features high-quality ball bearing steel (63 - 65 Rockwell Hardness [HRC]), pyrometer-controlled inductive hardening, two component ESD ergonomic handles with soft comfortable gripping surface, hard plastic core, dual leaf springs in blue steel, matched bearing rings, and friction lap joint with screw. The nut is made of hardened alloy steel to resist the high cutting load. The screw is fine-pitched for perfect joint adjustment.

**Order # 46-70000**

Item	Description	Length	12+	6+	1+
A	Oval Small Flush	4 ¾"	\$40.72	\$43.11	\$47.90
B	Large Oval Flush	5"	\$43.86	\$46.44	\$51.60
C	50° Angle Flush	5 ¼"	\$40.12	\$42.48	\$47.20
D	Tapered Small Flush	4 ¾"	\$40.72	\$43.11	\$47.90
E	Tapered Large Flush	5"	\$43.86	\$46.44	\$51.60
F	Tapered Large Full-Flush	5"	\$43.99	\$46.58	\$51.75
G	Tapered & Relieved Full-Flush	4 ¾"	\$40.38	\$42.75	\$47.50
H	Large Oval Full-Flush	5"	\$43.99	\$46.58	\$51.75
J	Tapered Small Full-Flush	4 ¾"	\$41.57	\$44.01	\$48.90
	Oval Small	4 ¾"	\$36.51	\$38.66	\$42.95
	Big Oval Semi-Flush	5"	\$41.57	\$44.01	\$48.90
	Oval Small Full-Flush	4 ¾"	\$41.57	\$44.01	\$48.90
	Tapered & Relieved Flush	4 ¾"	\$40.21	\$42.57	\$47.30



**ERGO-TEK CUTTERS AND PLIERS**

**One Touch and You'll be Gripped**

The Ergo-tek line represents the perfect combination of ultra high cutting quality and durability, with beauty and ergonomics almost beyond belief.

As soon as you see these hand tools, you'll fall in love with them. As soon as you hold and grip the ESD bi-component handles, you'll never want to put them down.

- High quality ball bearing steel
  - 45 Rockwell Hardness (HRC) for pliers
  - 63 Rockwell Hardness (HRC) for cutters
- Pyrometer-controlled inductive hardening
- Superior no-scratch/anti-glare satin finish
- All cutters available with three types of cutting blades: SEMI-FLUSH for soft and hard wire, FLUSH for very precise cutting or soft wire, and FULL-FLUSH for a perfect cutting of soft wire
- 2-Component ESD-safe user-friendly Ergonomic handles with a soft, comfortable gripping surface
- Dual leaf springs made of stainless steel
- Lap joint with screw in order to achieve a high level of strength and precision
- Nuts made of hardened alloy steel to resist the high cutting load
- Finely pitched screw for perfect joint adjustment
- Perfect symmetry

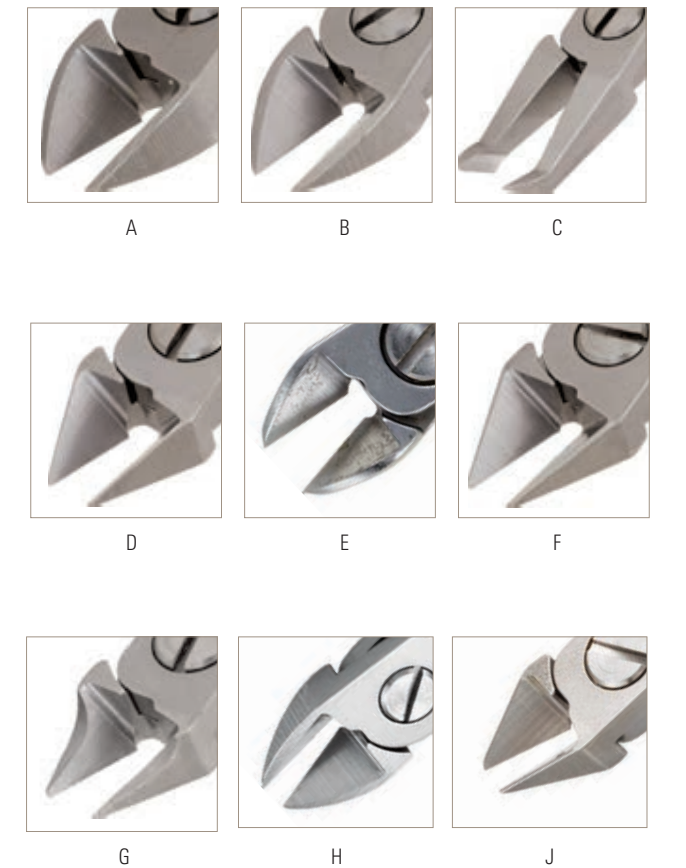





**REVERE PLIERS**

This exceptional line of quality pliers is made for the discriminating professional and inspired and designed by Alan Revere, a master goldsmith and founder and director of the Revere Academy of Jewelry Arts. Alan's passion for unquestionable quality and the highest standards of workmanship result in a superior line of German-crafted tools made to meet his specifications. Made of the highest quality carbon tool steel available, they are hand finished to meet exacting standards. Jaws have beveled corners. No plastic handles or springs for precise control and surface contact. Special tooling is used to create the unique Revere grip. Made in Germany.

**Order # 46-03990**

Item	Description	Length	12+	6+	1+
A	Revere Kit (4-Pieces)	5"	—	—	\$131.00
B	Chain Nose	5"	\$30.90	\$32.72	\$36.35
C	Round Nose	5"	\$30.90	\$32.72	\$36.35
D	Flat Nose	5"	\$30.90	\$32.72	\$36.35
E	Flat & Half Flat	5"	\$32.90	\$34.83	\$38.70

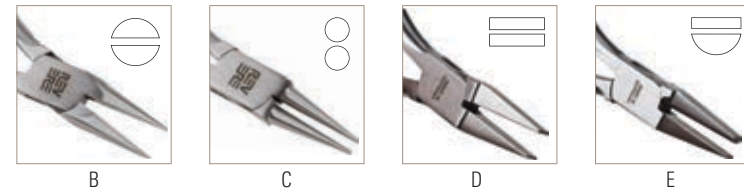

Set contains one of each: flat-nose, round nose, chain nose, chain long, end cutter, and diagonal cutter in a vinyl pouch.



**BOX-JOINT PLIERS**

Standard weight and size for medium to small work, these are precision pliers and nippers with box joints to eliminate side play and maintain alignment of jaws under stress. Heads are brightly polished, and handles have yellow vinyl cushion grips. Made in Germany.

**Order # 46-10000**

Item	Description	Length	12+	6+	1+
F	Box Joint Set	5 1/4"	\$117.09	\$123.98	\$137.75
G	Diagonal Cutter	5 1/4"	\$30.64	\$32.45	\$36.05
H	Flat Nose	5 1/4"	\$21.38	\$22.64	\$25.15
J	Round Nose	5 1/4"	\$21.38	\$22.64	\$25.15
K	Flush End Cutter	5 1/4"	\$28.82	\$30.51	\$33.90
L	Short Chain Nose	5 1/4"	\$21.38	\$22.64	\$25.15
M	Long Chain Nose	5 1/4"	\$23.29	\$24.66	\$27.40
N	Serrated Chain Nose	5 1/4"	\$21.38	\$22.64	\$25.15
P	Half-Round Nose/Flat Nose	5 1/4"	\$24.27	\$25.70	\$28.55

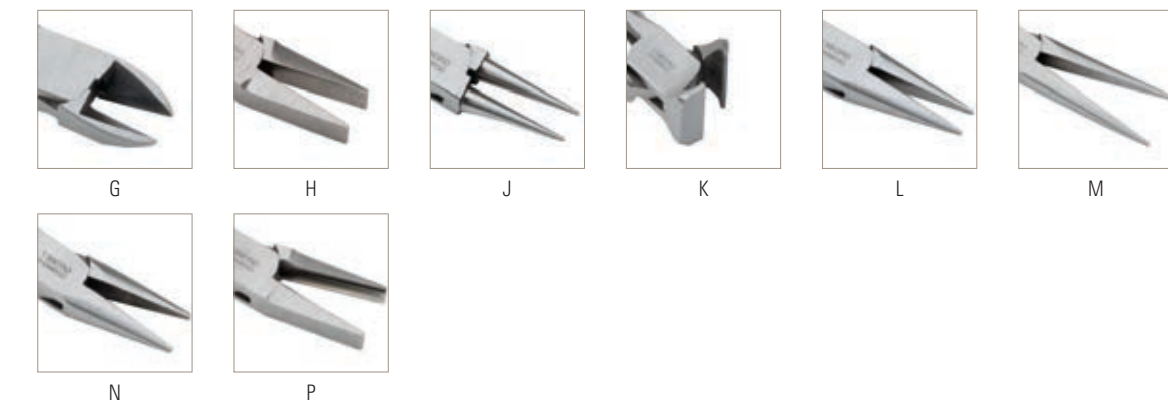

**SLIM-LINE PLIERS**

Made of high-quality, tool steel with box-joint construction, these slim-line pliers feature plastic grips and leaf springs. Made in Germany.

**Order # 46-05200**

Item	Description	Length	12+	6+	1+
A	Chain Nose	4 3/4"	\$18.53	\$19.62	\$21.80
B	Round Nose	4 3/4"	\$18.53	\$19.62	\$21.80
C	Flat Nose	4 3/4"	\$18.66	\$19.76	\$21.95
D	Oblique Flush Cutter	4 3/4"	\$24.27	\$25.70	\$28.55
E	Flush Cut End Cutter	4 3/4"	\$21.42	\$22.68	\$25.20
F	Diagonal Cutter	4 3/4"	\$21.17	\$22.41	\$24.90

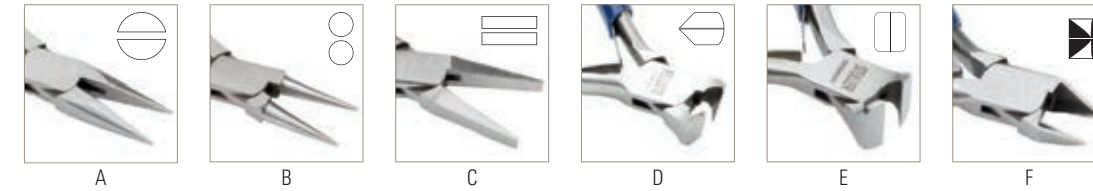

**BOX-JOINT PLIERS**

These pliers feature a comfortable rubber handle and a smooth operating box joint.

**Order # 46-80000**

Item	Description	Length	12+	6+	1+
G	Chain Nose	5 1/8"	\$8.20	\$8.69	\$9.65
H	Flat Nose	5 1/8"	\$8.20	\$8.69	\$9.65
J	Round Nose	5 1/8"	\$8.20	\$8.69	\$9.65
K	Bent Nose	5"	\$8.20	\$8.69	\$9.65
L	Half-Round	5 1/8"	\$8.76	\$9.27	\$10.30
M	Round Concave	5 1/8"	\$8.76	\$9.27	\$10.30
N	Flat Half-Round	5 1/8"	\$8.20	\$8.69	\$9.65



**BOX-JOINT PLIERS**

Quality box-joint pliers at an affordable price, these pliers have a brushed satin finish and smooth, non-marring jaws. Comfortable foam-grip handles feature a double-leaf spring return.

**Order # 46-05350**

Item	Description	Length	12+	6+	1+
P	Side Cutter	4 3/4"	\$9.35	\$9.90	\$11.00
Q	Flat Nose	4 3/4"	\$6.84	\$7.25	\$8.05
R	Round Nose	4 3/4"	\$6.84	\$7.25	\$8.05
S	Chain Nose	4 3/4"	\$6.84	\$7.25	\$8.05

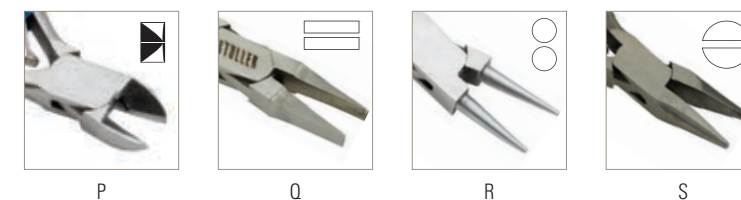

All items are priced at jeweler's cost, are sold each, unless otherwise noted, and are subject to change without notice. Visit [Stuller.com](http://Stuller.com) for our complete product selections, current pricing, and quantity price breaks. | 443





**ECONOMY LAP-JOINT PLIERS**

Good quality carbon-steel work pliers have smooth jaws with polished heads to prevent marking on soft metals and cushion grip handles.

**Order # 46-01700**

Item	Description	Length	12+	6+	1+
A	Flat Nose	4 1/2"	\$5.27	\$5.58	\$6.20
B	Round Nose	4 1/2"	\$5.27	\$5.58	\$6.20
C	Chain Nose	4 1/2"	\$4.51	\$4.77	\$5.30

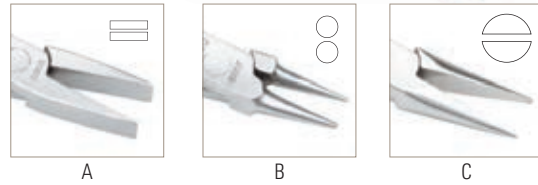

**NYLON SPECIALTY FORMING PLIERS**

The nylon jaw pliers are a necessity for the discerning jeweler. The quality nylon will not mar, scratch, bend, or twist. Be creative with these designer specialty pliers. Stainless steel box joint with comfort PVC grip allows for long periods of use without hand fatigue. Replacement jaws are available.

**Order # 46-05420**

Item	Description	Length	12+	6+	1+
D	Round/Flat Nose	4 1/2"	\$9.35	\$9.90	\$11.00
E	Small Round Nose	4 1/2"	\$9.35	\$9.90	\$11.00
F	Large Round Nose	5 1/2"	\$12.16	\$12.87	\$14.30
G	Tapered	4 1/2"	\$9.35	\$9.90	\$11.00

**REPLACEMENT JAWS**

**Order # 46-05430**

Item	Description	12+	6+	1+
H	Round/Flat Nose (for 46-0542)	\$1.40	\$1.49	\$1.65
J	Small Round Nose (for 46-0544)	\$1.40	\$1.49	\$1.65
K	Large Round Nose (for 46-0546)	\$1.40	\$1.49	\$1.65
L	Tapered (for 46-0548)	\$1.40	\$1.49	\$1.65

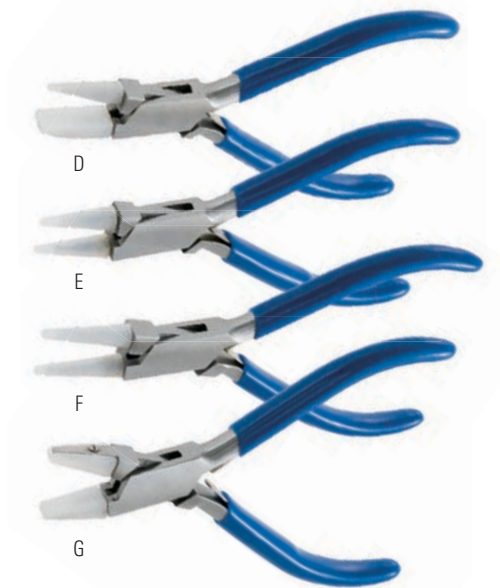
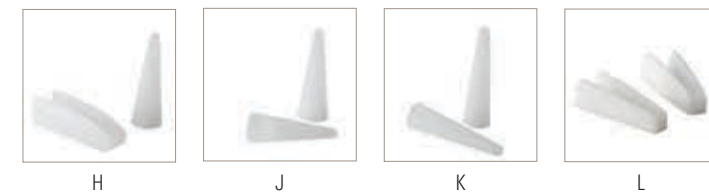

**NYLON BENDING PLIERS**

These jaw pliers are designed for bending or reshaping without scratching. Jaw is made of nylon and highly polished stainless steel.

**Order # 46-20800**

Item	Description	Length	12+	6+	1+
M	Bending	5 1/4"	\$19.42	\$20.57	\$22.85
N	Ring Bending	5 1/4"	\$19.42	\$20.57	\$22.85
P	Bracelet Bending	5"	\$19.08	\$20.21	\$22.45
Q	Ring Holding	5 1/2"	\$19.42	\$20.57	\$22.85
R	Flat Nose	5 3/4"	\$12.67	\$13.41	\$14.90
S	Tube Holding	6 1/2"	\$23.42	\$24.80	\$27.55

**REPLACEMENT JAWS**

**Order # 46-20810**

Item	Description	12+	6+	1+
M	Bending (for 46-2086)	\$4.46	\$4.73	\$5.25
N	Ring Bending (for 46-2084)	\$4.46	\$4.73	\$5.25
P	Bracelet Bending (for 46-2090)	\$4.46	\$4.73	\$5.25
Q	Ring Holding (for 46-2088)	\$4.46	\$4.73	\$5.25
R	Flat Nose (for 46-2082)	\$4.46	\$4.73	\$5.25
S	Tube Holding (for 46-2092)	\$4.68	\$4.95	\$5.50

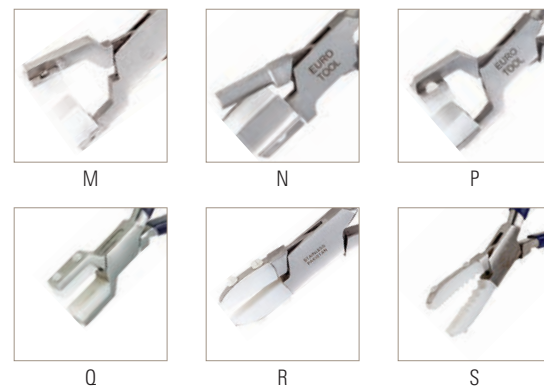

**BENDING PLIERS WITH TEXTURED GRIPS**

This line of bending pliers offers the best quality and price combination anywhere. Stainless steel, boxed-joint construction, and blue textured PVC handles assure years of satisfaction. Working surfaces feature rounded corners and are highly polished to prevent scratching precious metals. You will not find a better pair of bending pliers.

**Order # 46-00630**

Item	Description	Length	12+	6+	1+
A	Concave/Convex Bending	5"	\$16.83	\$17.82	\$19.80
B	Round Nose/Flat Nose Looping	5"	\$13.01	\$13.77	\$15.30
C	Flat Nose/Half-Round Bending	5"	\$13.01	\$13.77	\$15.30
D	Round Nose/Concave Nose Bending	5"	\$13.01	\$13.77	\$15.30

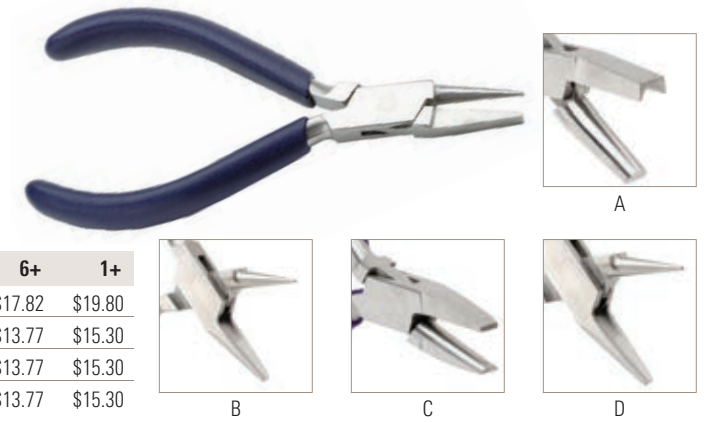

**STULLER COMFORT GRIP PLIERS**

Made of the finest tool steel and beautifully polished, with box-joint construction and double-leaf springs, these pliers offer the latest in ergonomic design. The handle width and soft non-slip texture ensure the user of less fatigue than with conventional handles. Made in Germany.

**Order # 46-15200**

Item	Description	Length	12+	6+	1+
E	Flush Side Cutter	4 3/4"	\$20.40	\$21.60	\$24.00
F	Flat Nose	4 3/4"	\$18.53	\$19.62	\$21.80
G	Round Nose	4 3/4"	\$18.53	\$19.62	\$21.80
H	Flush Oblique Cutter	4 3/4"	\$32.77	\$34.70	\$38.55
J	Flush End Cutter	4 3/4"	\$32.77	\$34.70	\$38.55
K	Chain Nose	4 3/4"	\$21.42	\$22.68	\$25.20
L	Bent Chain Nose	4 3/4"	\$19.30	\$20.43	\$22.70



**ROUND NOSE PLIER**

The ultimate ultra-fine round nose has fine smooth jaws that allow the user to make the smallest loops with utmost accuracy every time. The tip diameter measures less than one millimeter for the most delicate work. Smooth jaws are easy on the wire yet strong enough to hold without slipping. PVC comfort grip.

Order #	Description	Length	12+	6+	1+
<b>46-0541</b>	Ultra-Fine Tip Plier	4 1/2"	\$6.55	\$6.93	\$7.70



**90 DEGREE BENT NOSE PLIER**

Works well for stone setting, especially for small prongs and line bracelets. The 90° angle makes precise work easier. These pliers feature box-joint construction, cushion grips, and a leaf spring.

Order #	Description	Length	12+	6+	1+
<b>46-3085</b>	90 Degree Bent Nose Plier	5"	\$11.14	\$11.79	\$13.10







**MICRO MINI/FLAT NOSE PLIERS**

Use these reasonably priced stainless steel pliers for delicate tasks.

**Order # 46-30700**

Item	Description	Length	12+	6+	1+
A	Bent Flat Nose Pliers	5"	\$6.12	\$6.48	\$7.20
B	Split Ring Pliers	5 1/4"	\$7.78	\$8.24	\$9.15
C	Bead Knot Pliers	5"	\$8.80	\$9.32	\$10.35



A

B

C

**SLIM-LINE PLIERS**

This user-friendly line of pliers with black comfort grips and fine, precision points are offered at an exceptional price. Measures five inches (127mm) in length with a gentle return spring. Uncompromising quality, these pliers feature the best in comfort technology with black, oxidized, non-glare finish. They are designed for precision work.

**Order # 46-15000**

Item	Description	Length	12+	6+	1+
D	Side Cutter	5"	\$7.91	\$8.37	\$9.30
E	Chain Nose	5"	\$7.48	\$7.92	\$8.80



D

E

**PLIERS KIT**

These pliers feature comfortable rubber handles and smooth operating box joint.

Order #	Description	12+	6+	1+
<b>46-0539</b>	Slimline Pliers Kit (Set of 4)	\$13.94	\$14.76	\$16.40

**ECONOMY TOOL KIT**

This economy tool kit with zip pouch comes complete with all the tools you need to begin beading. It features chain nose pliers, round nose pliers, wire cutters, tweezers, a bead scoop, snips, and six modular and stackable drawers all zipped into a handy storage pouch. The complete kit is ready to travel and keeps tools neatly organized. Store various findings and beads in the drawers.

Order #	Description	12+	6+	1+
<b>46-0516</b>	7 Piece Repair Kit	\$13.09	\$13.86	\$15.40

**MINI TOOL KIT**

This set of mini tools is perfect for quick repairs and for travel. Contains all the tools necessary for wire wrapping and other stringing functions. These mini tools are 3" long. Set is complete with chain nose pliers, round nose pliers, flat nose pliers, fiber tipped pliers, and a cutter all zipped up into the pouch.

Order #	Description	12+	6+	1+
<b>46-0515</b>	5 Piece Repair Kit	\$11.22	\$11.88	\$13.20



**SETTING PLIERS**

Use for opening, closing, and tightening prongs. Slim nose allows for reaching small areas.

Order #	Description	Length	12+	6+	1+
<b>46-0058</b>	Stone Setting Pliers	5 1/2"	\$17.43	\$18.45	\$20.50

**STONE SETTING PLIERS**

Use to tighten loose prongs or for initial setting of stones. Made in Germany.

Order #	Description	Length	12+	6+	1+
<b>46-3480</b>	Setting Pliers	5"	\$37.27	\$39.47	\$43.85

**THE #1 CONNER BEAD SETTING PLIERS**

These #1 pliers will replace the common beading tool, making many jobs considerably easier. No longer will you need to hold items in the ring clamp and on the bench pin or to fill a fragile item with shellac. This tool gives you support from the underside to do common, everyday tightening, and setting stones, and much more. Use like a beading tool 50% to get things done faster and easier. Supports from underneath — no shellac needed. Use to hold stones (culet to table) while being heat-set into wax models.

Order #	Description	Length	12+	6+	1+
<b>46-4009</b>	#1 Beading Setting Pliers	4 1/2"	\$14.03	\$14.85	\$16.50

**THE #2 CONNER BEAD SETTING PLIERS**

These #2 pliers are especially helpful to set or tighten side stones on a basket setting and other mounting types. One side of the pliers has a slot for the wire under the stone and the other side has a beading tool cup on it. Simply slide the post through the slotted side and bring the beading tool down on the prong, making this type of work much quicker and easier. Use for setting and tightening accent stones surrounding center stones. Works well for earrings, with or without under bezel wires. Size of beading cup can be made smaller or larger.

Order #	Description	Length	12+	6+	1+
<b>46-4011</b>	#2 Beading Setting Pliers	4 1/2"	\$11.99	\$12.69	\$14.10

**STONE REMOVAL PLIERS**

Box joint allows perfect alignment of jaws. Cushion-grip handles are made for comfort. Remove stones easily, preventing damage. Can be used on all prong settings, clusters, channels, fishtails, and baguettes. Tips are thin and narrow to fit into tightly recessed areas and very small settings.

Order #	Description	Length	12+	6+	1+
<b>46-0059</b>	Stone Removal Pliers	6 1/2"	\$10.71	\$11.34	\$12.60



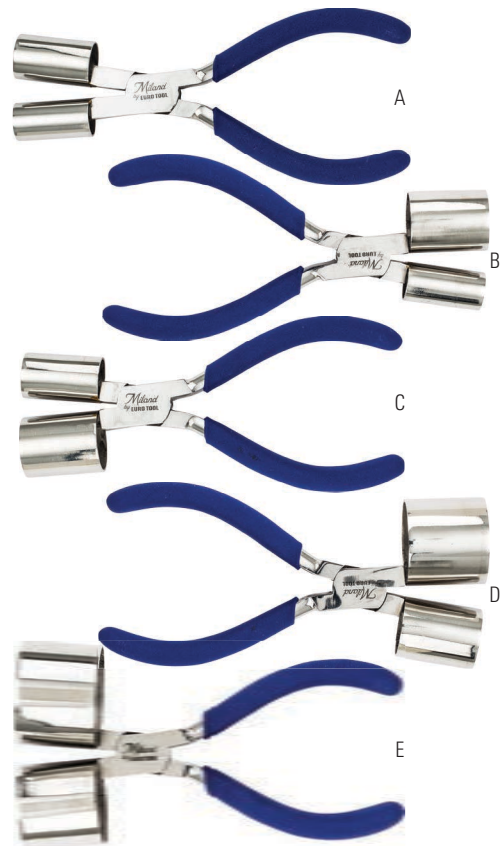

**MILAND™ DOUBLE CYLINDER BRACELET PLIERS**

MILAND™ Double Cylinder Bracelet Pliers have two different sized cylinders which are used to quickly put large radius curves into flat metal stock. Result can easily be resized on mandrel if desired. Perfect for making mens' and womens' bracelets.

Order # 46-2071

Item	OD	ID	Length	12+	6+	1+
A	1"	5/8"	6"	\$21.21	\$22.46	\$24.95
B	3/4"	5/8"	6"	\$21.21	\$22.46	\$24.95
C	1 1/8"	1 1/8"	6"	\$21.21	\$22.46	\$24.95
D	1 3/8"	1"	6"	\$21.21	\$22.46	\$24.95
E	1"	3/4"	6"	\$21.21	\$22.46	\$24.95



**MILAND™ ANTICLASTIC AND SYNCLASTIC PLIERS**

Anticlastic Pliers are similar to synclastic but produce a curve in opposite ways in two directions — saddle-shaped. Produces a fine, finished product in a fraction of the time without having to use a dapping tool.

Order # 46-2070

Item	Description	Length	12+	6+	1+
F	Synclastic Plier	8"	\$40.76	\$43.16	\$47.95
G	Anticlastic Plier	8"	\$40.76	\$43.16	\$47.95

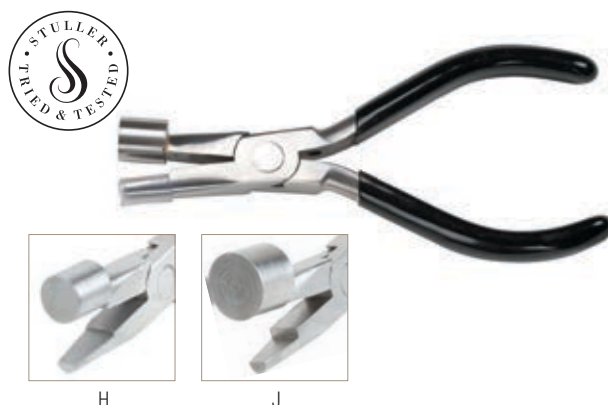

**WRAP N TAP RING LOOPING PLIERS**

You can wrap ring stock around the barrel-shaped jaw, then tap it slightly on a mandrel and instantly make a complete ring, half shank or quarter shank for repair. These pliers are especially good for hollow rings and rings with a design on one side, because the lower jaw is covered with PVC tubing and cannot scratch or mark. You get a perfect circle time after time with stock up to two millimeters thick. Made of stainless steel with PVC cushion grips.

Order # 46-40150

Item	Description	OD	Length	12+	6+	1+
H	Ladies	14mm	6"	\$18.66	\$19.76	\$21.95
J	Gents	16mm	6"	\$18.66	\$19.76	\$21.95

**SOLDER/CUTTER PLIERS WITH HOLE**

Cuts sheet solder in 1/16" squares or wire solder up to 18 gauge in 1/16" lengths for easy handling and melting. Made of stainless steel with box-joint construction.

Order #	Description	Length	12+	6+	1+
46-4035	Solder-Cutter Plier	5 1/2"	\$17.43	\$18.45	\$20.50



**TRIPLE BAIL LOOPING PLIERS**

Multi-size looping pliers can make a variety of loops from two to nine millimeters for a variety of combinations. Made of stainless steel with double-leaf spring.

Order #	Description	Length	12+	6+	1+
46-0406	Triple Bail Plier	5 3/4"	\$15.90	\$16.83	\$18.70



**WIRE LOOPING PLIERS**

Stainless steel wire looping pliers, also known as coupling pliers, enable you to bend wire easily. Three round jaws in one and box-jointed for durability, these finely polished pliers feature one round and one concave jaw.

Order #	Description	Length	12+	6+	1+
46-3080	Wire Looping Plier	5 3/4"	\$11.56	\$12.24	\$13.60



**MASTER COILER PLIERS**

Make loops and coils without marking precious wire. Most concave/convex pliers nick, but the new Master Coiler allows one to hold the wire with the flat jaw while rotating the round jaw to form the perfect loop. Features comfort grips, rust-resistant, highly polished, stainless steel jaws, and a standard step jaw for consistent loops and coils.

Order #	Description	Length	12+	6+	1+
46-9005	Master Coiler Plier	5 3/4"	\$11.22	\$11.88	\$13.20



**WIRE-TWISTING PLIERS**

Safely twist wire up to .06 gauge. Simple one-pull action and automatic return twists wire quickly into a strand that won't unravel. Hardened and tempered.

Order #	Description	Length	12+	6+	1+
46-9010	Wire-Twisting Plier	9"	\$20.49	\$21.69	\$24.10







**BERGEON HEAVY-DUTY SPRUE CUTTER**

These top-quality cutters help reduce hand fatigue from constant usage by using a special linkage that multiplies your hand pressure many times. Extra-long handles provide additional leverage to help make cutting easier. Cuts sprues up to 1/8" (3mm) thick. Jaws are 7/8" (22mm) long and pointed for easier access to tight areas. Made in Switzerland.

Order #	Description	Length	12+	6+	1+
64-6496	Sprue Cutter	5 5/8"	\$124.61	\$131.94	\$146.60



**SPRUE CUTTER DELUXE**

Features compound construction with hardened, tool-steel jaws and chrome-vanadium steel. Cuts soft wire up to 1/8" (3mm) and hard wire up to 0.039" (1mm). Weighs 12 1/2 oz.

Order #	Length	12+	6+	1+
46-4030	9 1/2"	\$78.46	\$83.07	\$92.30



**PARALLEL-ACTION DIAGONAL CUTTER**

Jaws open and close parallel along entire length, providing firm, vise-like grip. Features spring action handle.

Order #	Length	Cutting Capacity	12+	6+	1+
46-5320	5 1/2"	1/4"	\$34.60	\$36.63	\$40.70



**COMPOUND CUTTER**

This heavy-duty diagonal cutter with compound leverage cuts sprues with minimal effort. Made in Germany.

Order #	Length	Cutting Capacity	12+	6+	1+
53-9326	7 1/2"	1/8"	\$36.68	\$38.84	\$43.15

**SEMI-FLUSH CUTTER**

High quality jewelry cutters are designed for use with casting trees. Perfectly sized tip-end goes inside of the casting tree easily. Made in Japan

**Order # 46-4021**

Item	Description	Length	12+	6+	1+
A	Flush Cutter	7 7/8"	\$22.61	\$23.94	\$26.60
	Semi-Flush Cutter	7 7/8"	\$19.64	\$20.79	\$23.10



**SPECIAL PLIERS FOR REMOVING BRACELET LINKS**

Bracelet link removing pliers

Order #	Description	Length	12+	6+	1+
59-0773	Bracelet Link Removing Plier	5 5/8"	\$23.72	\$25.11	\$27.90



**SPECIAL PLIERS FOR REMOVING BRACELET LINKS**

Bracelet link removing pliers

Order #	Description	Length	12+	6+	1+
59-0774	Bracelet Link Removing Plier	4 3/8"	\$19.47	\$20.61	\$22.90



**HOLE-PUNCHING PLIERS FOR LEATHER STRAPS**

Use these pliers for punching holes in straps. Bolt 1.50 mm

Order #	Description	Length	12+	6+	1+
59-0771	Hole Punching Plier	5 5/8"	\$28.82	\$30.51	\$33.90





**ESCA ITALY JEWELERS PLIERS AND CUTTERS**

Quality and precision make these box-joint pliers and cutters perfect for medium to small work. Durable and affordable. Satin finished heads with vinyl cushion grips. Set contains all six pliers and cutters in a vinyl pouch, and is priced lower than if purchased separately.

Item	Order #	Description	Length	12+	6+	1+
A	46-2690	Esca Plier Set		\$74.49	\$78.88	\$87.64
B	46-2610	Round Nose	5"	\$13.39	\$14.18	\$15.75
C	46-2600	Chain Nose	5"	\$13.39	\$14.18	\$15.75
D	46-2620	Flat Nose	5"	\$13.39	\$14.18	\$15.75
E	46-2630	Half-Round Nose/Flat Nose	5"	\$13.39	\$14.18	\$15.75
F	46-2640	Flush End Cutters	4½"	\$13.39	\$14.18	\$15.75
G	46-2650	Diagonal Cutters	5½"	\$13.39	\$14.18	\$15.75



**ESCA ITALY SLIM-LINE PLIERS AND CUTTERS**

Experience the same quality, precision, and durability as the jeweler's box-joint line, but they are smaller and lightweight. These feature satin finished heads with vinyl cushion grips. Set contains all six pliers and cutters in a vinyl pouch and is priced lower than if purchased separately.

Item	Order #	Description	Length	12+	6+	1+
A	46-2790	Esca Slimline Plier Set		\$74.49	\$78.88	\$87.64
B	46-2700	Chain Nose	4¾"	\$13.39	\$14.18	\$15.75
C	46-2710	Round Nose	4¾"	\$13.39	\$14.18	\$15.75
D	46-2720	Flat Nose	4¾"	\$13.39	\$14.18	\$15.75
E	46-2730	Half-RoundNose/Flat Nose	4¾"	\$13.39	\$14.18	\$15.75
F	46-2740	Flush End Cutters	4¾"	\$13.39	\$14.18	\$15.75
G	46-2750	Diagonal Cutters	4¾"	\$13.39	\$14.18	\$15.75

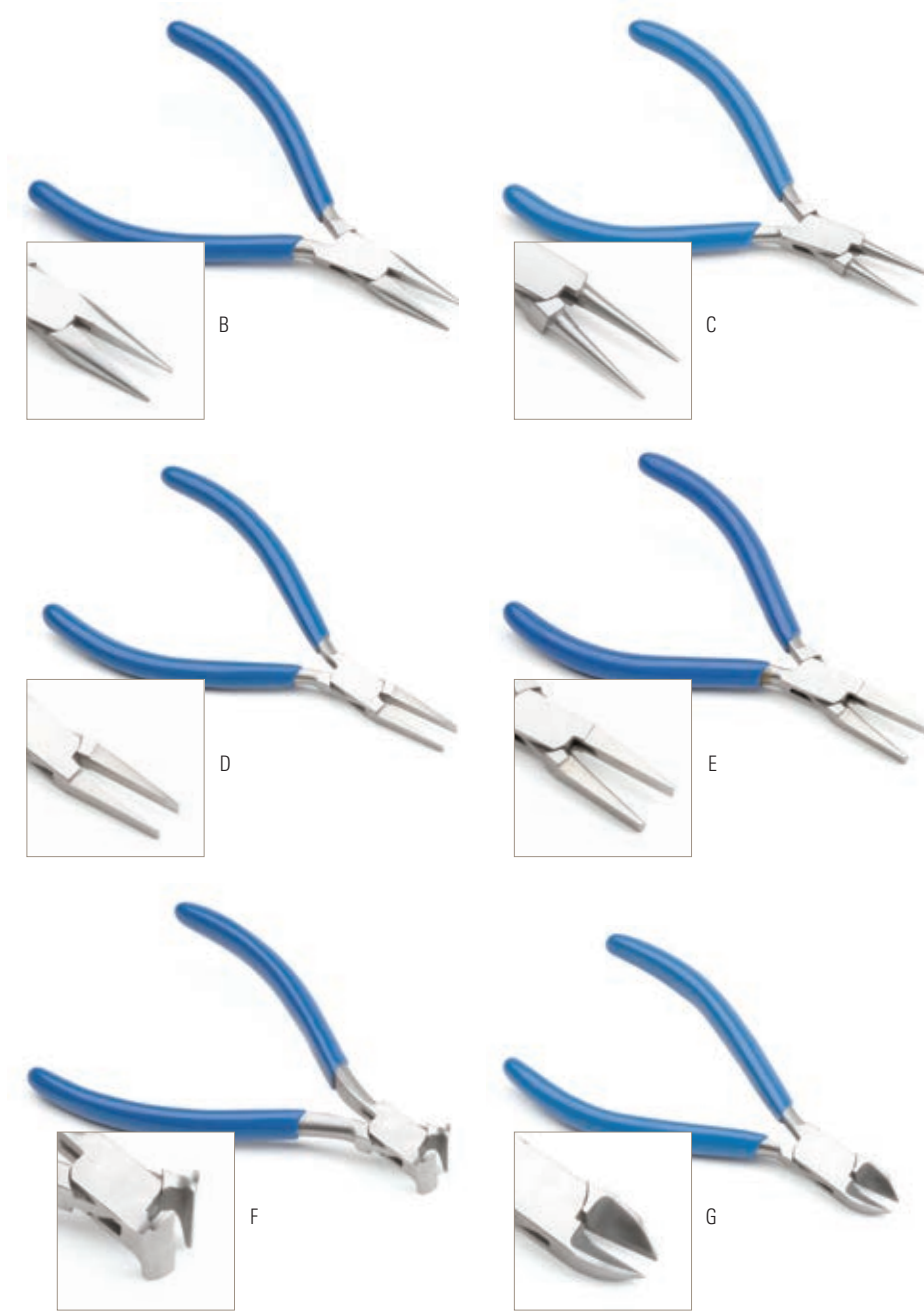

All items are priced at jeweler's cost, are sold each, unless otherwise noted, and are subject to change without notice. Visit [Stuller.com](http://Stuller.com) for our complete product selections, current pricing, and quantity price breaks. | 453



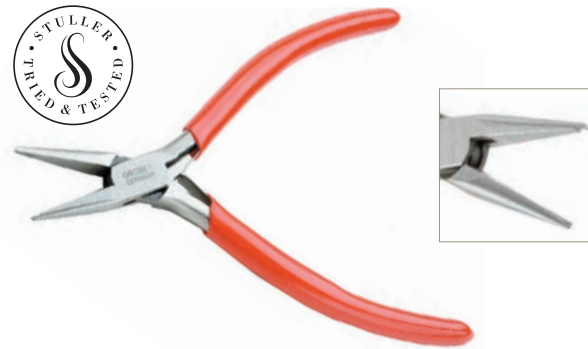

**PRONG-OPENING PLIERS**

Ideal for opening prongs without fracturing stones, the top jaw is a claw that grips the prong cleanly, and the lower jaw is grooved to hold the prong. No pressure is applied on the top of the stone. Made in Germany.

Order #	Description	Length	12+	6+	1+
46-4000	Prong-Opening Plier	4½"	\$31.45	\$33.30	\$37.00



**PRONG-OPENING PLIERS**

These pliers feature a thin claw to get behind prongs. The angle and length to bottom jaw provides precise leverage to minimize stone damage. Lower jaw is grooved to prevent sideways slipping. Made in Germany.

Order #	Description	Length	12+	6+	1+
46-3990	Prong-Opening Plier	5¼"	\$35.32	\$37.40	\$41.55



**PRONG-LIFTING PLIERS**

Prong-lifting pliers are designed for lifting prongs to remove set stones. The lower jaw supports the base of the prong, while the knife-sharp upper jaw lifts the prong. Jaw length is 0.125" (3mm). Made in Germany.

Order #	Description	Length	12+	6+	1+
46-4004	Prong-Lifting Plier	5¼"	\$41.18	\$43.61	\$48.45



**RING-HOLDING PLIERS**

Large, grooved, semi-circular jaws hold rings during filing or polishing. These pliers feature a box joint.

Order #	Description	Length	12+	6+	1+
46-0380	Ring-Holding Plier	5¼"	\$12.75	\$13.50	\$15.00



**PRONG-CLOSING PLIERS**

Designed specifically for closing prongs on line bracelets quickly, efficiently, and properly, the angled jaw allows the user to properly bend the prong, making every setting job much easier than with conventional pliers. Perfect-set pliers also work great for setting stones on pins, cuff links, coin rings, and lightweight or promotional jewelry. These were invented by a jeweler.

Order #	Description	Length	12+	6+	1+
46-2430	Prong-Closing Plier	5½"	\$11.65	\$12.33	\$13.70

**CONCAVE RING-BENDING PLIERS**

These unique box-joint pliers are made to round any size due to their exclusive shape. The lower (concave) jaw goes from 10.5mm at the tip to 17mm at the base.

Order #	Description	Length	12+	6+	1+
46-2900	Concave Ring-Bending Plier	6½"	\$44.88	\$47.52	\$52.80



**LARGE RING-BENDING PLIERS**

This ring bending plier has a box-joint with cushion grip handles for maximum leverage. Jaws are concave/convex for shaping shanks, with the convex being slightly thinner than the concave jaw. Made in Germany.

Order #	Description	Length	12+	6+	1+
46-2905	Large Ring-Bending Plier	6½"	\$35.32	\$37.40	\$41.55



**LOOP-CLOSING PLIERS**

Jaws are shaped and smoothly finished to close loops, jump rings, bracelet links, bows, etc., without distorting or scratching. With box joint and cushion grip handles

Order #	Description	Length	12+	6+	1+
46-0057	Loop-Closing Plier	4½"	\$11.65	\$12.33	\$13.70



**BOW-OPENING PLIERS**

Heavy-duty, special-joint pliers. Jaws are kept closed by spring in handle. When handles are compressed, jaws open. Use to open bows, links, and jump rings

Order #	Description	Length	12+	6+	1+
46-3030	Bow-Opening Plier	5¼"	\$46.03	\$48.74	\$54.15



**BOW-CLOSING PLIERS**

Heavy-duty pliers used for closing small bows and loops. Strong and rugged enough to be used to bend ring shanks.

Order #	Description	Length	12+	6+	1+
46-3060	Bow-Closing Plier	6½"	\$42.80	\$45.32	\$50.35



**HEAVY-DUTY RING-BENDING PLIERS**

Extra-heavy pliers used for bending metal at right angles, closing bows, and bending ring shanks.

Order #	Description	Length	12+	6+	1+
46-0062	Ring-Bending Plier	6½"	\$13.22	\$14.00	\$15.55





**HOLE-PUNCH PLIERS**

This handy tool allows you to punch additional holes to size leather or plastic bands. Allows a two millimeter punch with precise clearance for a clean cut. Made of fine steel for long life. Euro-grip handles for comfort.

Order #	Description	Length	12+	6+	1+
46-3050	Hole Punch Plier	5 3/4"	\$9.18	\$9.72	\$10.80



**PUNCH PLIERS**

Powerful, lightweight hand tool punches holes in all types of metals. Punch accurate, precision round holes in steel, aluminum, brass, copper, plastic, etc., with one hand. Great for use where electricity or power is not available. Comes with a side gauge for depth adjustment. It is perfectly balanced with curved handles for a natural grip. Will pierce up to 14 gauge mild steel. Comes with seven popular sizes: 3/32", 1/8", 5/32", 3/16", 7/32", 1/4", and 9/32".

Order #	Description	LxH	12+	6+	1+
46-0000	Round Power Punch	8 3/4" x 3 3/8"	\$35.32	\$37.40	\$41.55



**REVOLVING-PUNCH PLIERS**

A convenient, spring-tension, self-opening tool for punching round holes in leather, plastic, rubber, and similar materials. Made of plated steel with six tapered and hollow, hardened-steel punches. Punch sizes: 2.0, 2.5, 3.0, 3.5, 4.0, and 4.5mm.

Order #	Description	Length	12+	6+	1+
46-3057	Revolving Punch Plier	9"	\$11.05	\$11.70	\$13.00



**METAL HOLE-PUNCH PLIERS**

Will punch copper or silver as thick as 18 gauge. With ergonomic handles and tempered replaceable pin, these pliers will save you time and money. The pliers are made of thick carbon steel and come with an extra 1/8" replaceable pin.

Order # 46-04040

Item	Description	Length	12+	6+	1+
A	Metal Hole Punch Plier	5 1/4"	\$14.03	\$14.85	\$16.50
B	Replacement Pins	1 1/8"	\$6.55	\$6.93	\$7.70

**SKILL ELECTRIC CUTTERS**

Remove rings almost instantly with these high-quality, powerful, cordless electric ring cutters with recharging unit. It will cut the strongest alloys in less than 10 seconds without heat or discomfort. The blade guard slips under the ring and completely protects the hand and fingers. Sterilization of the chrome blade assembly can be easily done. Three-year warranty on cutting unit—excluding blade. Comes with one gasket. Also takes four AA batteries. US PAT 4864730.

Order # 48-18030

Item	Description	12+	6+	1+
A	Electric Ring Cutter	—	—	\$200.10
B	Replacement Blades (pack of 2)	\$50.07	\$53.01	\$58.90



**RING CUTTERS**

Use to cut rings while on or off the finger. The lower jaw of the cutter slides between the ring and hand. The circular saw can be turned by the handle to cut through the ring. Handle is knurled and non-slip. It is nickel-plated, except for saw and will not cut titanium. Comes with attachment to hook to electric cutter.

Item	Order #	Description	Length	12+	6+	1+
C	48-1800	Ring Cutter with 1 Saw	4 1/2"	\$44.92	\$47.57	\$52.85
D	48-1801	Replacement Saw		\$11.52	\$12.20	\$13.55
E	48-1802	Replacement Saw (Diamond)		\$37.83	\$40.05	\$44.50
F	48-1806	Beaver Blade		\$13.01	\$13.77	\$15.30

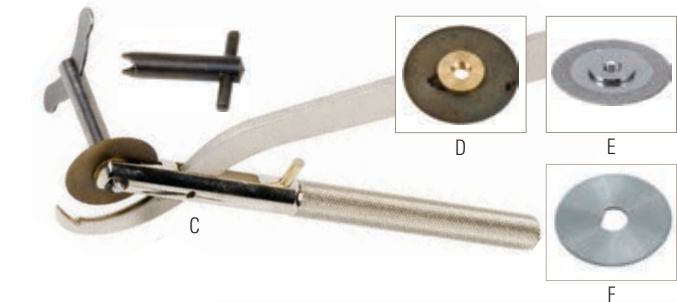

**MICRO-SNIP BEADING SHEARS**

Ideal for use in bead stringing and thread snipping.

Item	Order #	Length	12+	6+	1+
G	53-2800	3 1/2"	\$3.74	\$3.96	\$4.40



**STULLER RING CRACKER**

Allows you to crack any ceramic or tungsten ring with no pain to the wearer. Very easy to use. Anybody can assist with the removal of these alternative metals. The kit comes with a Ring Cracker, two pairs of safety glasses, and instructions. Only removes tungsten and ceramic rings.

Item	Order #	Description	1+
H	58-2440	Ring Cracker	\$94.65



**PRECISION SCISSORS**

Use for beading and other delicate work. Handles are large and made of black ABS. Small, pointed blades are made of high-quality stainless steel. Blades are held together with a stainless steel high-impact rivet and nylon washer, which provide smooth cutting and extended life.

Item	Order #	Length	Blade Length	12+	6+	1+
J	53-6200	4"	1 1/4"	\$11.05	\$11.70	\$13.00



**CROWN SCISSORS**

Made of forged steel, expertly tempered and hardened, the hand-ground edges retain a keen cut after long use. Straight blades are used to cut hard wire or sheet up to B&S #27 and soft wire up to B&S #16. Blades are short and stubby.

Item	Order #	Blade Length	Blade Width	12+	6+	1+
K	53-8070	3/16"	1/4"	\$17.68	\$18.72	\$20.80





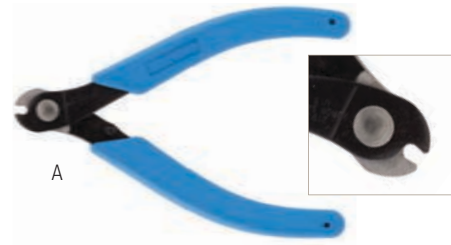

**XURON® WIRE SHEARS**

These HWAC shears are rated for hard wire, music wire, and throttle cable. These are ideal for the craftsperson who needs to cut a variety of metals.

Item	Order #	Description	Length	12+	6+	1+
A	46-0504	Wire and Cable Shear	5½"	\$14.96	\$15.84	\$17.60



**XURON® MICRO-SHEAR®**

A superior tool offering both precision cutting and exceptional life, the Xuron Micro-Shear is ideal for cutting soft metals and solders. Cutting edges are heat treated to a hard 57-59 RC.

Item	Order #	Length	Jaw Length	12+	6+	1+
B	46-0509	6"	1½"	\$18.70	\$19.80	\$22.00

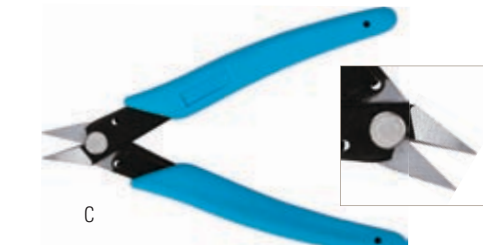

**XURON® HIGH PRECISION SCISSORS**

Ultra-precise, the Xuron scissor cuts fine or delicate items with a clean, square-edge cut. Cushion grips and return spring provide increased comfort and precision. Rated for cutting soft metals up to 0.005" or materials such as silk, embroidery, floss, or thin mylars.

Item	Order #	Length	Jaw Length	12+	6+	1+
C	46-0508	5"	½"	\$14.96	\$15.84	\$17.60

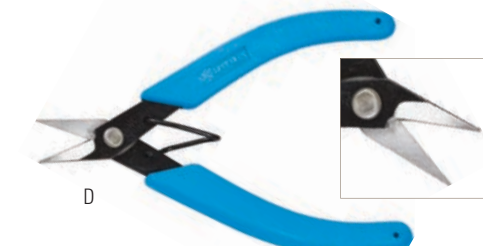

**XURON® HIGH DURABILITY SCISSORS**

Features precision-ground high carbon steel cutting edges. Excellent for cutting solder and sheets of light gauge metal up to 0.030" (0.8mm). For fine and all bead cords, these pliers have serrations on one edge to keep material secure while cutting.

Item	Order #	Description	Length	12+	6+	1+
D	46-0513	High Durability Scissors	6"	\$18.70	\$19.80	\$22.00

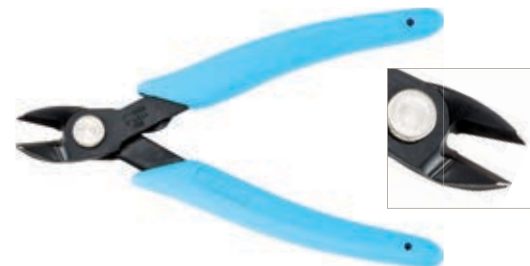

**XURON® MAXI-SHEARS**

A short-handled version of our Model 2175 Maxi-Shear™ Flush Cutter, the Xuron Maxi-Shear provides a more comfortable alternative for those with smaller hands. Flush cuts soft wire up to 12 AWG (2mm). An excellent choice for chainmaille and wire art enthusiasts. Soft Xuro-Rubber® handle grips and Light-Touch® Return spring lend comfort and control.

Order #	Description	Length	12+	6+	1+
46-0499	Flush Cutter for Smaller Hands	6"	\$14.32	\$15.17	\$16.85

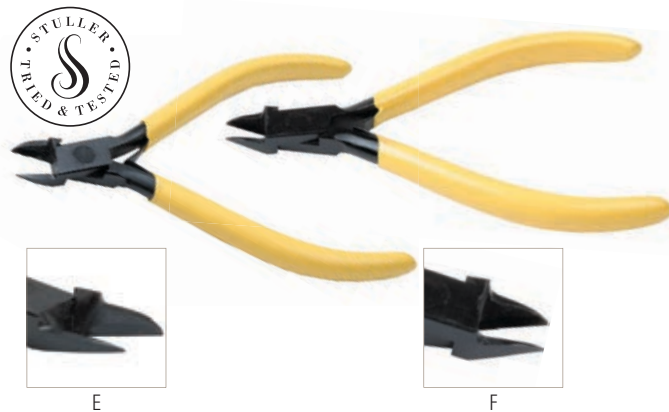

**PRECISION SCISSORS**

These cutters are specifically designed for multi-strand beading wire and full-flush with jaws induction hardened to 60-62 Rockwell. Used properly, this degree of hardness assures a clean cut time after time. Cutting edges are precisely aligned and the black oxide, non-glare head has a relieved design for reaching into tight areas. This quality German cutter also features double-leaf spring and yellow PVC handles. Use on flexible beading wire and soft wire only.

Order # 46-40130

Item	Description	Length	12+	6+	1+
E	Cutter	4 ½"	\$21.25	\$22.50	\$25.00
F	Pointed Jaw Cutter	4 ½"	\$26.35	\$27.90	\$31.00

**XURON® MICRO-FLUSH® DELUXE CUTTER MICRO SHEAR® FLUSH CUTTERS**

Micro Shear applies only to products that utilize blade by-pass shear-cutting action. This patented design requires about half the effort to cut a wire as compared to conventional compression-type wire cutters. All primary cutting surfaces are generated on high-precision, three microprocessor-controlled, self-diagnostic grinding equipment. This ensures that the grinding on every blade is as identical as computer controlled tolerances allow.

Features include

- Ergonomic shape
- Xuro-rubber™ grips
- Black finish to eliminate glare
- Light Touch™ return spring

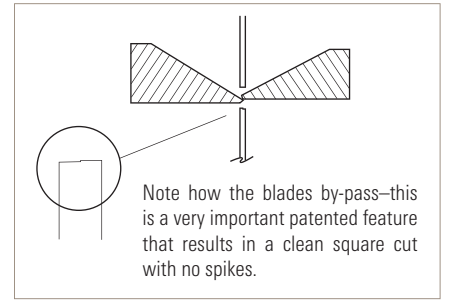

**XURON® MAXI-SHEAR® FLUSH CUTTERS**

Tough 6" flush cutters featuring a patented Micro-Shear® cutting action. Cuts soft metals and wire up to 14 gauge (1.6mm) thick. Leaves clean square cuts. Features an ergonomic shape and non-slip Xuro-Rubber™ grips. Available in two styles: standard flush cutter and flush cutter with lead retainer that holds small pieces of wire as it is cut. Overall length 5.82". Jaw length 0.47".

Order #	Description	Length	12+	6+	1+
46-0501	Flush Cutter	5½"	\$14.37	\$15.21	\$16.90



**XURON® MICRO-SHEAR® FLUSH CUTTERS**

This pair flush cuts soft wire up to 20 gauge (0.8mm) thick.

Order #	Length	Blade Length	12+	6+	1+
46-0500	5"	½"	\$8.20	\$8.69	\$9.65



**XURON® MICRO-SHEAR® FLUSH CUTTERS**

This tapered head design allows positioning, even on finepitch leads. Tapered head flush cuts soft wire up to 14 gauge (1.6mm) thick.

Order #	Length	Blade Length	12+	6+	1+
46-0503	5"	⅝"	\$18.70	\$19.80	\$22.00



**XURON® MICRO-FLUSH® DELUXE CUTTER**

Made of hardened tool steel and induction-hardened jaws, the cutting edge is relieved for a clean cut with a fine point for tight work. With comfort grips and a steel spring, this cutter is perfect for those smaller jobs and reasonably priced. They are excellent for small prongs, chain, and other items.

Order #	Description	Length	12+	6+	1+
46-4010	Flush Cutter	4¾"	\$9.95	\$10.53	\$11.70





**ITALIAN FLUSH CUTTERS**

Use these incredible tools to speed up production of loop making and cutting with the same tool. One tip of these pliers has a small sharp surface that is able to cut soft metals quickly and efficiently. Extremely high-quality tool, rivet joint, coil spring and ergonomic handles. Made in Italy.

Item	Order #	Description	Length	12+	6+	1+
A	46-4051	Semi-Flush Cutter	5¾"	\$27.16	\$28.76	\$31.95
B	46-4050	Round Nose Plier/Cutter	5¾"	\$45.90	\$48.60	\$54.00



**JEWELER'S SNIPS**

This ultra high-quality cutter is an excellent choice for making flush cuts in Beadalon® beading wires, artistic wire, and other soft wires. Ergonomic handles and spring tension make production less tiresome. Not for use with memory wire. Made in Italy.

Order #	Description	Length	12+	6+	1+
46-4052	Italian Flush Cutter	5¾"	\$27.16	\$28.76	\$31.95



**LIGHTWEIGHT METAL SNIPS**

These economically priced designer nipper tool features high quality rivet joint construction, ergonomic handles, and a single leaf spring, helping to make these nippers very easy and comfortable to use and an extremely good value. For use on German style wire, artistic wire, and all soft crafting wires. Made in Italy.

Order #	Description	Length	12+	6+	1+
46-4053	Designer Nipper Tool	5¾"	\$8.93	\$9.45	\$10.50



**SIDE CUTTERS**

These cutters are designed for larger jobs where strength and leverage are important. These side cutters measure six inches (150mm) and feature cushioned grips, gentle coil-return spring, and semi-flush jaws.

Order #	Description	Length	12+	6+	1+
46-0070	Side Cutter	6"	\$4.21	\$4.46	\$4.95

**ULTRA FLUSH CUTTERS**

Italian-made cutters have safety clips to keep wire or other materials from flying when cut. Features a new ergonomic handle to lessen fatigue.

Order #	Description	Length	12+	6+	1+
46-4029	Flush Cutter	5½"	\$22.95	\$24.30	\$27.00



**SEMI-FLUSH SIDE CUTTERS**

These cutters, made in Europe, offer strength in a precision side cutter at an affordable price. Features a smooth spring return.

Order #	Description	Length	12+	6+	1+
46-4028	Semi-Flush Side Cutter	5"	\$22.48	\$23.81	\$26.45



**POWER MAX™ CUTTERS**

Ergonomic, compound cutters feature jaws that are made of induction-hardened, high-grade steel with a semi-flush bevel for close work. Its ergonomically shaped handles prevent fatigue and injury.

**Order # 46-40200**

Item	Description	Length	12+	6+	1+
A	Cutter	6½"	\$34.21	\$36.23	\$40.25
B	Full Flush Cutter	6½"	\$34.43	\$36.45	\$40.50



**POCKET MEMORY WIRE CUTTER**

Specially designed for cutting hard wire, these cutters feature hardened jaws to slice effortlessly through spring-tempered wire. They leave a clean, safe-to-handle straight edge on Remembrance and plated steel memory wire, and can even be used to cut Beadalon® jewelry cable. Made in USA.

Order #	Description	Length	12+	6+	1+
46-3994	Wire Cutter	3½"	\$9.35	\$9.90	\$11.00



**C. H. P. MILANO ITALIAN FLUSH CUTTERS**

Made of high grade tool steel, these Italian cutters are perfect for lighter jobs where a flush cut is essential. This shear action cutter, made in Italy, features a blackened nonglare head, return spring, and high friction ergonomic grips. Maximum cut is 16 gauge 1.5mm copper wire.

Order #	Description	Length	12+	6+	1+
46-4002	Flush Cutter	5½"	\$9.35	\$9.90	\$11.00







**PARALLEL ACTION PLIERS**

Heavy Flat Nose Pliers have V-slot running the length of the serrated jaws for holding wire. Combination Pliers have flat nose with V-slot and serrated jaw that is combined with a wire cutter. Chain Nose Pliers have smooth nose, non-serrated, tapered pliers for a variety of projects.

**Order # 46-50600**

Item	Description	Length	12+	6+	1+
A	Heavy Flat Nose Plier	5½"	\$20.40	\$21.60	\$24.00
B	Combination Plier	5"	\$28.82	\$30.51	\$33.90
C	Combination Plier	5½"	\$30.01	\$31.77	\$35.30
D	Chain Nose Plier	5"	\$28.73	\$30.42	\$33.80

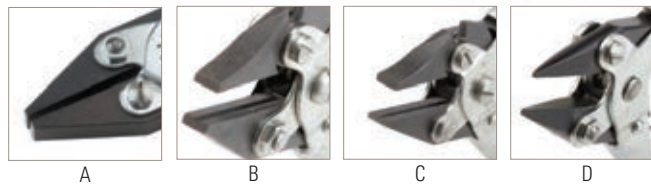

**LIGHT FLAT NOSE PARALLEL PLIERS**

With parallel action, a square, vise-like grip is provided by the jaws, opening and closing parallel along entire length. Handles and jaws are nickel-plated.

**Order # 46-28500**

Item	Description	Length	12+	6+	1+
E	Serrated Jaws with V-Slot	5"	\$20.19	\$21.38	\$23.75
F	Smooth Jaws	5"	\$22.14	\$23.45	\$26.05
G	Half-Round Jaws	5"	\$54.19	\$57.38	\$63.75

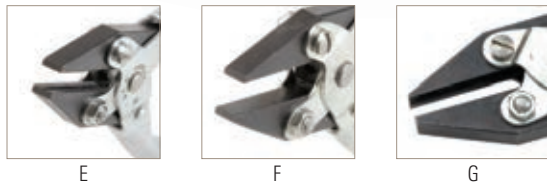

**SWISS BENDING PLIERS**

Bending pliers are designed for bending flat and round stock, sheet metal, and wire into various shapes. Made of aircraft-quality aluminum, they bend up to 4mm round or flat stock and 15mm sheet width. Made in Switzerland.

Order #	Description	Length	12+	6+	1+
46-9006	Swiss Bending Plier	7¾"	\$141.70	\$150.03	\$166.70



**SUPERFIT™ PARALLEL RING-BENDING PLIERS**

Use parallel action to bend and hold rings without distorting shanks.

Order #	Description	Length	12+	6+	1+
46-0064	Ring Bending Plier	5½"	\$51.55	\$54.59	\$60.65

**GEM SET PLIERS**

Simplify stone setting. Lever action improves control and mechanical advantage. Adjustable parallel action helps to avoid over-tightening stones. Sold in two styles. Made in the USA.

- Heavy-duty with slightly shorter, less tapered jaws
- Standard jaws taper to a finer tip allowing easy access to small stones

**Order # 46-34820**

Item	Description	12+	6+	1+
A	Standard Jaw	\$33.58	\$35.55	\$39.50
B	Heavy-Duty Jaw	\$33.62	\$35.60	\$39.55



**HEAVY-DUTY CHAINMAKER SHEARS**

These are chainmaker's shears that contain precision, fine blades and blue handles. Made in Germany.

Order #	Length	Blade Length	12+	6+	1+
46-5020	5¾"	1½"	\$14.03	\$14.85	\$16.50



**JEWELER'S SHEARS**

Excellent for clipping chains, solders, and thin metals, the tempered steel, polished jaws provide an easy cut.

**Order # 46-50150**

Item	Description	Length	12+	6+	1+
C	Straight Shear	7"	\$14.96	\$15.84	\$17.60
D	Straight Shear w/ Spring	7"	\$22.36	\$23.67	\$26.30



**STRAIGHT-EDGE JEWELER'S SNIPS**

Use for cutting templates and patterns from metal sheet up to B&S #20 medium hard metal to B&S #16 soft metal. 1 1/2" (38mm) cutting length. Made in Germany.

Order #	Description	Length	12+	6+	1+
46-5005	Straight Edge	7"	\$16.11	\$17.06	\$18.95



**LIGHTWEIGHT METAL SNIPS**

Use for cutting templates and patterns from metal sheet up to B&S #20, medium hard metal to B&S #16, and soft metal. 1½" (38mm) cutting length. Made in Germany.

Order #	Description	Length	12+	6+	1+
53-8030	Curve Snips	7"	\$16.79	\$17.78	\$19.75



# POLISHING



25,000 RPM



175 lbs

### QUATRO STAND-UP POLISHING UNIT

The most efficient and powerful polishing station on the market, this unit features whisper-quiet technology for the jewelry industry. Captures gold and platinum in two separate air streams in two separate bags, so platinum dust can be kept separate. This Quatro stand-up high-volume polishing unit has 900 CFMs, this unit takes in less air but moves it faster. The motor for this unit spins at about 25000 rpm.

- Heavy-duty clearview hood provides maximum work area and dust-free working environment.
- Air inlet is located below the polishing wheel to maximize precious metal recovery.
- Three-stage filtration captures ALL of your precious metal particles, filters included.
- 1/2 HP two-speed double-shaft lathe
- Two clearview hoods with LED lights
- Drawers on left and right are not included.

Use **47-4224** PreFilters. Unit size: 53" H X 39" W X 19" L. Weight: 175lbs

**Order # 47-4221**

Description	WxDxH	CFM	1+
Quatro Stand-Up Polishing Unit High Volume	39"×19"×53"	900 CFM	\$2,999.00
Drawer - With Lock			\$170.70
Drawer - Without Lock			\$130.30



3,600 RPM



175 lbs

### QUATRO STAND-UP POLISHING UNIT

The most efficient and powerful polishing station on the market, this unit features whisper-quiet technology for the jewelry industry. Captures gold and platinum in two separate air streams in two separate bags, so platinum dust can be kept separate. This Quatro stand-up high-volume polishing unit has 900 CFMs, this unit takes in less air but moves it faster. The motor for this unit spins at about 25000 rpm.

- Heavy-duty clearview hood provides maximum work area and dust-free working environment.
- Air inlet is located below the polishing wheel to maximize precious metal recovery.
- Three-stage filtration captures ALL of your precious metal particles, filters included.
- 1/2 HP two-speed double-shaft lathe
- Two clearview hoods with LED lights
- Drawers on left and right are not included.

Use **47-4224** PreFilters. Unit size: 53" H X 39" W X 19" L. Weight: 175lbs

**Order # 47-4221**

Description	WxDxH	CFM	1+
Single Motor Unit	39"×19"×53"	1200 CFM	\$2,570.00
Drawer - Without Lock			\$130.30
Drawer - With Lock			\$170.70

### QUATRO FULLY ENCLOSED STAND-UP POLISHING UNIT

Specialty Stand-Alone System

- Progressive three-stage filtering system
- Specially designed filter bypass system maximizes efficient rouge capture
- Most efficient polishing station on the market
- True HEPA Filter ensures 99.97% efficiency on the capture of precious metal particles
- One-piece containment design allows for larger working area
- Has the ability to accommodate quick chuck changer
- Fully enclosed design aids in quieter operation
- Continuous duty brushless motor for long term performance
- CoolBlue polishing motors are 1/2 HP, two-speed

Order #	Description	WxHxD	CFM	1+
<b>47-4235</b>	Polishing Unit with Lathe 1/2 HP	39"×53"×19"	900 CFM	\$2,437.00



### QUATRO STAND-UP DOUBLE STATION POLISHING UNIT

- Most efficient polishing station on the market
- True HEPA Filter ensures 99.97% efficiency on the capture of precious metal particles
- Two workstations with two separate collection bags, allowing for the separation of precious metals (platinum dust captured in one clearview filter bag and gold dust captured in the other)
- CoolBlue motor supplied is 1/2 HP, two-speed
- Quiet yet powerful
- Clearview hoods provide for a dust-free work environment
- Lapper containment hood (with LED) captures at lapper source
- Continuous-duty motor for long-term performance

Order #	Description	WxHxD	CFM	1+
<b>47-4222</b>	Double Station	45"×59"×19"	1200 CFM	\$2,999.00



170 lbs

### QUATRO POLISH AND LAPPING UNIT

Premium Polishing-Grinding Recovery System

- Most efficient polishing station on the market
- True HEPA Filter ensures 99.97% efficiency on the capture of precious metal particles
- Two workstations with two separate collection bags, allowing for the separation of precious metals (platinum dust captured in one clearview filter bag and gold dust captured in the other)
- CoolBlue motor supplied is 1/2 HP, two-speed
- Quiet yet powerful
- Clearview hoods provide for a dust-free work environment
- Lapper containment hood (with LED) captures at lapper source
- Continuous-duty motor for long-term performance
- One Lapper hood (Lapper sold separately)

Order #	Description	WxHxD	CFM	1+
<b>47-4223</b>	Premium Polishing-Grinding Recovery System	45"×59"×19"	1200 CFM	\$2,775.00

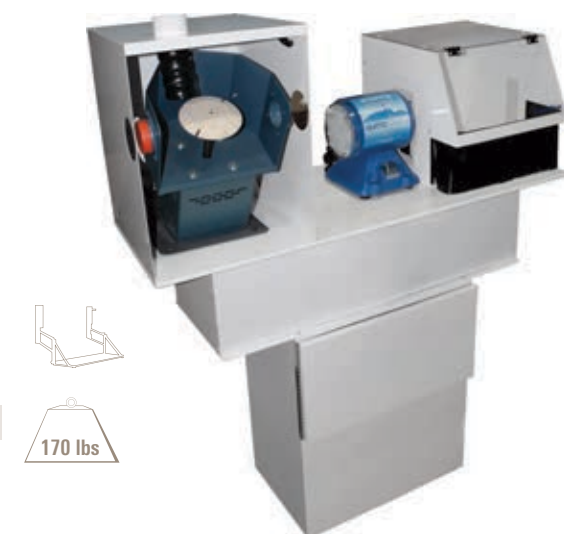

170 lbs





**JUNIOR POLISHING UNIT**

- Design ensures that your shop is clean
- Capture your gold inside filter bag, then send it for refining
- HEPA filter guarantees clean environment and ensures that air leaving the unit is absolutely clean
- Clearview enclosure contains all precious metals
- Maximum free air 600 CFM, two-speed motor ¼ HP
- Light bulb included

Order #	Description	W×L×H	1+
47-4999	Deluxe Polisher	24"×20"×50"	\$1,595.00

**VELOCITY X-SERIES DUST COLLECTOR**

Includes four pre-filters and six feet of heavy-duty hose per port.

Item	Order #	Description	W×L×H	Airflow	1+
A	47-4040	Single-Port X1	16"×14"×25"	175 CFM	\$950.00
B	47-4043	Double-Port X2	17"×14"×25"	360 CFM	\$1,199.00
C	47-4046	Four-Port	23"×18"×25½"	580 CFM	\$1,550.00
D	47-4200	Eight-Port	18"×34"×22"		\$1,952.35

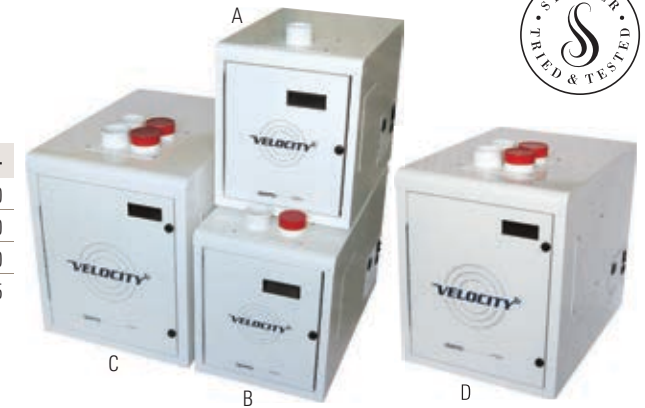

**VELOCITY HICAP**

High-capacity debris collection similar to the velocityX4. Lower maintenance is required due to high-capacity precious metals storage. Comes with legs and plastic pail for easy debris removal. Quatro benefits from a proven design.

- Highest and most effective dust retention
- 99.9% filter efficiency
- Maintenance-friendly design-filter can be accessed and cleaned in seconds
- High-capacity precious metals debris storage allows for lower maintenance
- Brushless motor with no motor maintenance

Dimensions with intake hood: 28" W x 6" H x 18" D  
Weight: 50 lbs operating Voltage: 115/1/60, 1.6 amps (also available in 240/1/50) CFM:800

Order #	Description	W×H×D	12+	6+	1+
47-4182	4-Port Dust Collector	22½"×20"×13½"	—	—	\$1,895.00
47-4183	8-Station Collector	22½"×20"×13½"	—	—	\$2,320.00
47-4049	Velocity X4 Pre-Filter (Pack of 20)		\$48.11	\$50.94	\$56.60
47-4048	Replacement Cartridge Filter		\$101.32	\$107.28	\$119.20
47-4033	On/Off Remote		\$41.23	\$43.65	\$48.50

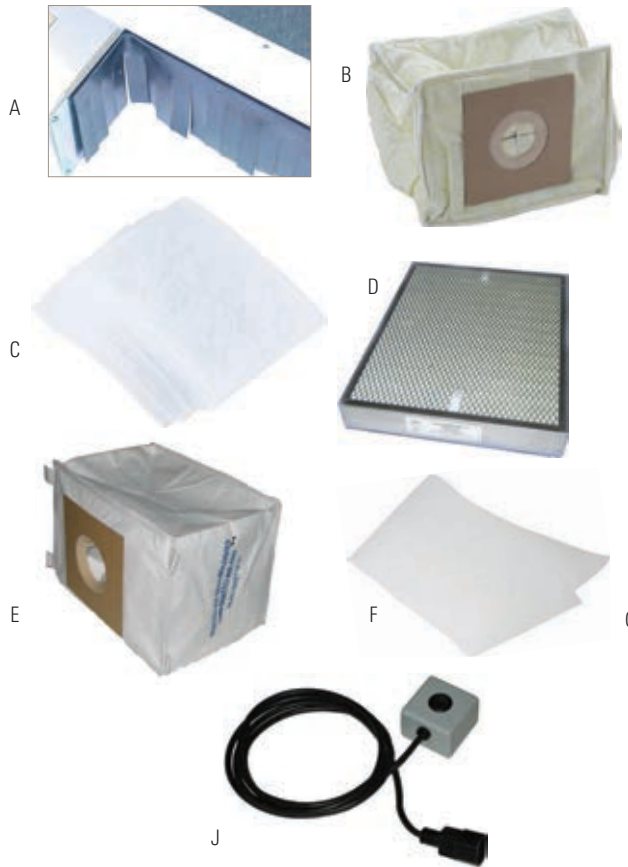

**QUATRO REPLACEMENT PARTS**

Item	Order #	Description	12+	6+	1+
A	47-4752	Replacement Flaps (2 Pair)	\$24.86	\$26.33	\$29.25
B	47-4225	Yellow Filter Bags	\$84.15	\$89.10	\$99.00
C	47-4224	Pre-Filter for SPU Pack of 20	\$39.53	\$41.85	\$46.50
D	47-4216	HEPA Filter	\$127.97	\$133.54	\$139.10
E	47-4215	Filter Bags	\$55.71	\$58.13	\$60.55
F	47-4213	Pre-Filter	\$46.46	\$48.48	\$50.50
G	47-4119	Plastic Viewer Door (2 pack)	\$28.22	\$29.88	\$33.20
H	47-4108	Quatro Light Fixture	\$85.00	\$90.00	\$100.00
J	47-4033	On/Off Remote	\$41.23	\$43.65	\$48.50

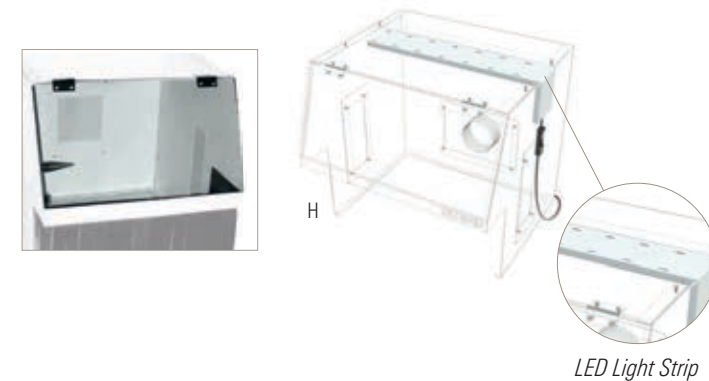

**GOLDMAT**

Sticky surface captures and holds on to gold and precious metals. Each mat contains 30 sheets.

Item	Order #	Description	W×L	12+	6+	1+
K	47-4106	Goldmat	24"×36"	\$47.30	\$50.09	\$55.65
	47-4111	Goldmat	24"×46"	\$55.21	\$58.46	\$64.95

**VELOCITY REPLACEMENT PARTS**

Item	Order #	Description	12+	6+	1+
E	47-4203	On/Off Switch	\$10.67	\$11.30	\$12.55
F	47-4041	Replacement Filter For X1	\$65.28	\$69.12	\$76.80
G	47-4174	Cartridge Filter For X2 & X4	\$45.56	\$48.24	\$53.60
H	47-4042	Velocity X4 Pre-Filter (Pack of 20)	\$37.78	\$40.01	\$44.45
J	47-4045	Velocity X1 Pre-Filter (Pack of 20)	\$42.08	\$44.55	\$49.50
K	47-4048	Velocity X2 Pre-Filters (Pack of 20)	\$101.32	\$107.28	\$119.20





**QUATRO CB POLISHER**

Quatro's first benchtop dust collector system that features a high-efficiency, three-stage filtering system and an intelligent design that will notify you when it's time to change filters. Three-stage filtration: rouge prefilter, extra surface dust filter, true 99.97% HEPA filter. Designed for use with inside ring polishers.

Order #	Description	W×L×H	1+
47-4208	TableTop Polisher	9"×20"×9"	\$699.00



**QUATRO GOLD VAULT**

This compact dust collector features total collection inside the filter with no precious metal waste. It is whisper quiet and comes with bag and refillable cartridge filter. Ideal for repair shops or any other areas where engraving, grinding, polishing, and mixing investments will be done. Electrical requirements: 120/1/60-7amps or 230/1/50-4amps. Control panel: fused for current protection

Order #	Description	W×L×H	Per Unit	1+
47-4172	Dust Collector	9"×20"×9"	Each	\$648.00
47-4176	Box Filter		Each	\$110.10



**QUATRO JET STREAM**

The Quatro Jet-Stream is a quiet, compact, and powerful dust collector. It is easy to connect to your bench or workstation to help keep your breathing zone clean and free of particulate matter. The Jet-Stream uses a two-stage filtering system that starts with an easy access replaceable bag filter that captures larger particulates and then an OSHA approved HEPA filter that will remove particulate matter down to sub-micron particulate levels. Compact and comes with bag filter and HEPA filter. Whisper quiet?ideal for engraving applications or small repairs.

Order #	Description	W×L×H	Per Unit	1+
47-4195	Jet Stream	10"×14"×12"	Each	\$699.00
47-4196	Filter Bags		Pack of 5	\$55.75
47-4198	Brushes		Pack of 2	\$20.20



**QUATRO BASIC DUST COLLECTOR**

Mini dust collector with high-speed turbine motor. Small footprint for tight spaces. Both are 23 pounds.

Item	Order #	Description	W×L×H	1+
A	47-4201	Basic with Foot Pedal	7"×16"×10"	\$399.95
B	47-4201	Basic with Hand Pedal	7"×16"×10"	\$399.95
C	47-4173	Filter Bags Pack of 5		\$32.20



Find added video content on [Stuller.com/VideoCenter](http://Stuller.com/VideoCenter).

**QUATRO COOL BLUE MOTOR**

Filter keeps dirt out. Motor runs longer, cleaner, and cooler. Less heat = longer life. All motors are two-speed and accommodate a 1/2" straight spindle.

Item	Order #	Description	W×L×H	1+
A	47-3970	1/2 HP Single Shaft	8 1/2"×13 1/2"×9 3/4"	\$339.00
B	47-3971	1/2 HP Double Shaft	8 1/2"×17 1/2"×9 3/4"	\$369.95
	47-3972	3/4 HP Single Shaft	8 1/2"×13 1/2"×9 3/4"	\$349.00
	47-3974	Filter w/Support Kit	6"	\$25.70
	47-3975	Filter (6-Piece)	5 1/2"	\$29.30



**QUATRO POLISHING HOOD**

Item	Order #	Description	12+	6+	1+
	47-4753	ClearView Hood	\$245.65	\$260.10	\$289.00
C	47-4109	Illumination Polish Hood	\$104.55	\$110.70	\$123.00
D	47-4094	Fume Extraction Flex Arm	\$81.56	\$86.36	\$95.95
	47-4064	Fume Extraction Flex Arm w/Cone Bracket	\$165.71	\$175.46	\$194.95



**QUATRO ACCESSORIES**

Item	Order #	Description	12+	6+	1+
E	47-4218	Dual LED Light Kit	\$102.17	\$108.18	\$120.20
F	47-4104	Upgrade Kit for Clearview	\$63.54	\$67.28	\$74.75
G	47-4752	Replacement Flaps (2 Pair)	\$24.86	\$26.33	\$29.25
H	47-4095	Slide Bar 2 1/2 in.	-	-	\$65.65
J	47-4096	Slide Bar 3 in.	\$38.42	\$40.68	\$45.20
K	47-4039	On/Off Foot Pedal	\$84.15	\$89.10	\$99.00
L	47-4038	Quatro DC Adaptor Plate	\$47.30	\$50.09	\$55.65
M	47-4050	6' Heavy-Duty Hose	\$36.93	\$39.11	\$43.45
N	47-4051	12' Heavy-Duty Hose	\$71.91	\$76.14	\$84.60
	47-4052	25' Heavy-Duty Hose	\$139.95	\$148.19	\$164.65
P	47-4054	Dust Collector Adaptor	\$36.93	\$39.11	\$43.45
Q	47-4097	Quatro Fish mouth	\$81.56	\$86.36	\$95.95
	47-4135	Automatic Slide Valve Adapter Box	-	-	\$100.00
R	47-4135	Automatic Slide Valve	-	-	\$100.00







**ARBE DELUXE DOUBLE-SPINDLE POLISHING SYSTEM**

Fully enclosed hoods feature exclusive super-flow technology directing 100% air flow into inlets. The most powerful dust collector manufactured in the industry. First stage cartridge filter captures all solid particulate down to 1/3 micron. Second stage HEPA exhaust filter (at 99.99% efficiency) captures all airborne allergens including dust and pollen. Polishing system incorporates a high base and heavy-duty, totally sealed, and permanently lubricated ball bearing, PROSERIES line of polishing motors is rated at 3450 RPM. High-impact mahogany laminate bench top provides a spacious and clean environment, also enabling easy maintenance of work area. Motor HP: 1/2 CFM 1100 Overall W x D x H: 48" x 24" x 43" Dust Collector W x D x H: 18" x 29" x 28" Bench Top W x D: 48" x 28"

Item	Order #	Description	WxLxH	1+
A	47-4220	Double Spindle Polishing System	48"x24"x43"	\$3,094.80
B	47-4133	Replacement HEPA Filter		\$132.35
C	47-4132	Replacement Cartridge Filter		\$185.45

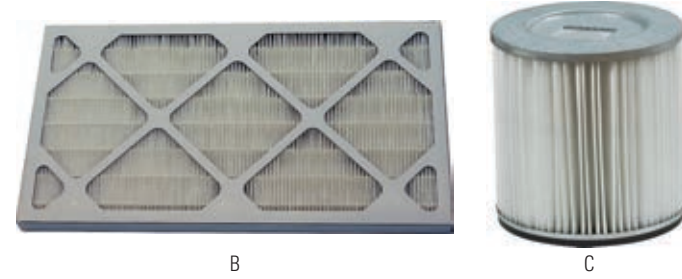

**ARBE TABLETOP LARGE DOUBLE-SPINDLE POLISHER**

Squirrel cage blowers provide the strongest suction in their class. Sealed and insulated cabinets provide maximum dust collection efficiency. Quick and easy filter replacement. Totally sealed and permanently lubricated. Unique, tapered, and threaded shaft design virtually eliminate all vibration. Capable of handling up to eight-inch-diameter buffs. Bulbs not included.

Item	Order #	Description	WxLxH	1+
C	47-4993	Large Double Polisher	32 1/2"x22"x12"	\$495.00
D	47-4994	Double Polisher	22 1/2"x17"x12"	\$414.80
E	47-4995	Single Polisher	15"x17"x10"	\$339.00
ACCESSORIES				
	47-4147	Double Spindle Motor	15"x17"x10"	\$205.00
	47-41410	Tapered Spindle Right		\$9.10
	47-41410	Tapered Spindle Left		\$9.10
	47-4148	Single Spindle Motor	15" x 17" x 10"	\$184.00
	47-4127	Replacement Single Filters (Pack of 3)	9 3/4"x13"x2"	\$28.65
	47-4128	Replacement Double Filters (Pack of 3)	12"x22 1/2"x2"	\$34.30
	47-4129	Replacement Large Filters (Each)	11 1/4"x29 1/4"x2"	\$17.05



**ARBE ENCLOSED TABLETOP POLISHING MACHINE**

The fully enclosed tabletop polishing machine is the only unit of its kind. The unit gives jewelers all the benefits of an enclosed polishing system without sacrificing all the space required for the traditional floor model units. The unit incorporates a suction motor which generates 600 CFM, making it the strongest tabletop polishing machine in the industry. This incredible suction, along with the enclosed design, will dramatically improve any jewelry store or studio immediately. In addition to the incredible suction, the unit uses a super-efficient pleated filter media which captures 99.99% of all particulate that passes through it. The motor runs at 52 decibels.

**Order # 47-4775**

Item	Description	12+	6+	1+
A	Polishing Machine	-	-	\$846.15
B	Replacement Filter	\$39.33	\$41.04	\$42.75

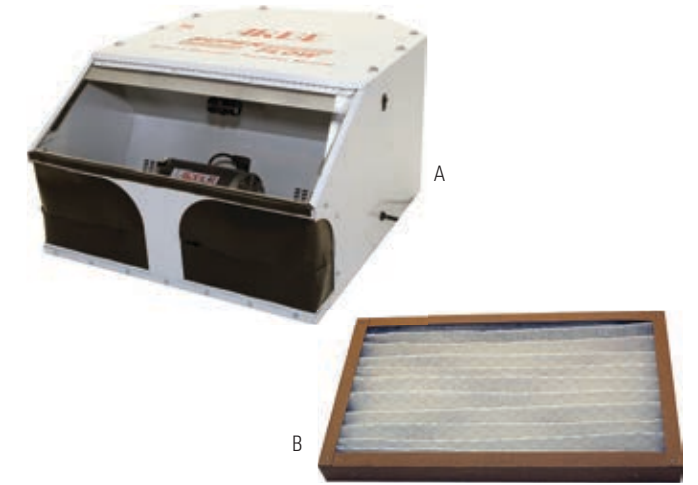

**ARBE SUPER-FLOW ENCLOSED POLISHING HOOD**

This is the only enclosed jeweler's polishing hood on the market that is made in the USA. It is fabricated out of steel, incorporating the super-flow feature which helps direct all debris into the back of the hood.

Order #	Description	WxLxH	1+
47-4768	Enclosed Polishing Hood	14"x15"x15 1/4"	\$290.00



**ARBE JEWELER'S BENCH VACUUM SYSTEM**

This jeweler's bench vacuum system offers dual filtration with one disposable vacuum bag for all solid particulate (grindings, fillings, etc.) and one charcoal filter to capture all smoke fumes. This unit is lightweight and versatile. Additional electrical outlet for convenience. Comes complete with collecting unit, six feet of hose, and steel fish mouth hood.

**Order # 47-4123**

Item	Description	12+	6+	1+
C	Bench Vacuum System	-	-	\$561.54
	Charcoal Filter	\$28.52	\$29.76	\$31.00
	Disposable Air Filter	\$27.88	\$29.09	\$30.30







**DURSTON DOUBLE POLISHING MOTOR**

All Durston models are built from 1.5mm (15 gauge) steel rather than 1mm (18 gauge) steel which is used on other polishing machines today. This creates a strong, sturdy construction by which Durston is so well known. Filters can conveniently be removed from the side, freeing up valuable storage space on top of the machine.

**Order # 47-4156**

Item	Description	12+	6+	1+
A	Polishing Motor Double	-	-	\$1,540.00
B	Replacement Filters	\$11.18	\$11.66	\$12.15
C	Replacement Lights	\$88.27	\$92.11	\$95.95



C

**BEST BUILT ENCLOSED POLISHER**

The Best Built polishing system comes with a ¾ HP, fully sealed, heavy-duty, permanently lubricated ball bearing polishing motor. The hoods have efficient, cool fluorescent lighting. Lights are enclosed behind a glass shield, which protects and keeps the bulbs clean. With a unique double filter system, it combines the technology of a dense, pleated filter with a tightly woven cotton bag filter, ensuring maximum recovery. Features

- ½ HP suction motor creates 450 CFM
- Rust-proof spindles
- Heavy-duty 12-gauge steel cabinet
- Access for hands can be customized
- 110 volts/20 amps
- Dimensions: 37" x 22" x 52"

**BEST BUILT MOTORS**

- Fully sealed ball bearing motor
- ½" straight shaft
- Rust resistant spindles



Item	Order #	Description	W×L×H	1+
D	47-4408	Enclosed Double Unit	37"×22"×52"	\$1,995.00
	47-4399	Top Only		\$825.03
	47-4409	Filter (Pleated)		\$101.00
	47-4402	Dust Collector Bag	9½"×18"	\$12.15
	47-4404	Dust Collector Bag	18"×18"	\$16.20



D

**FOREDOM® LIGHTED WORK CHAMBER**

Foredom's Work Chamber is a great addition for dental and other lab technicians, jewelers, carvers, and fabricators working with small workpieces. It offers excellent visibility and keeps dust and debris contained when grinding, sanding, polishing and drilling workpieces that fit in your hand. The compressed air nozzle swivels and air flow can be adjusted from low to high and directed to funnel dust and debris away from the workpiece, through the back of the chamber and into Foredom's New Dust Collector (34-2239) or other dust collection systems. Features LED light tilts to focus where needed. Compressed air nozzle has variable flow of air up to 90 PSI or six bars and pivots to direct air on the workpiece, funneling dust and shavings away. Vacuum port fits a 2¼" diameter hose for connection to a dust collector, shop vacuum, or other device. A two-pin style plug outlet for dust collectors with a remote on/off switch is located in the back. Power switch on the front for the light can also remotely activate a separate dust collector. Polycarbonate shields are hinged and secured with screws to contain dust and debris. 2½X magnifier is five inches in diameter and has 10X insert for closer work. It flips up and out of the way when not needed. Padded wrist rests on both sides. Tray (10¼" x 6⅝" with ⅝" lip) is watertight and easy to remove for cleaning.

Item	Order #	Description	12+	6+	1+
A	34-2246	Work Chamber	-	-	\$399.00
B	34-2249	LED Light Assembly	\$26.68	\$27.84	\$29.30
B	34-2249	LED Bulb (Plug-In)	\$13.80	\$14.40	\$15.00
C	34-2247	4mm Individual Hose Connector	\$2.85	\$2.98	\$3.10
C	34-2247	4mm-6mm Individual Union Reducer	\$4.51	\$4.70	\$4.90
C	34-2247	4mm Individual Air Hose	\$5.98	\$6.24	\$6.50
D	34-2248	6mm Individual Hose Connector	\$2.85	\$2.98	\$3.10
D	34-2248	6mm Individual Air Hose	\$5.98	\$6.24	\$6.50

Kit Order #	Description	12+	6+	1+
34-2247	4mm Air Port Kit	\$13.48	\$14.06	\$14.65
34-2248	6mm Air Port Kit	\$13.48	\$14.06	\$14.65



A



B



C



D

**FOREDOM® VARIABLE-SPEED DUST COLLECTOR**

Perfect for any lab, studio, and work space that creates harmful dust and debris, it is simple to use and ideal for anyone concerned about working in a clean and safe environment. Foredom's variable-speed MADC20 dust collector is whisper-quiet at 52dbA with powerful suction at 115CFM. The cyclone with polycarbonate collection chamber pre-filters 99% of all debris and the HEPA filter eliminates 99.98% of debris up to 0.3micron. This quality-built single-station unit has casters for easy portability, is simple to use, and basically maintenance free. It is an excellent companion to Foredom's MALC15 lighted work chamber, but it is a stand-alone unit for collecting dust from grinding, polishing, debarring, and sanding wood, metal, die stone, plaster, and many other materials. Use when working with dry materials only. Two-year warranty.

MADC20 Includes:

- Cyclone dust collector with collection chamber
- Remote switch with nine-foot cable
- Remote connector for MALC15
- Power cord
- Five-foot vacuum hose
- Two HEPA Filters. Filter has a 16 Merv Rating, 99.8% of all particles 0.3 micron and larger

Specifications:

- Weight: 30½ lb
- Ship Weight: 40 lb
- 19 1/2"H x 15 1/4"W x 15¼"L
- Cyclone: 16½"H x 7-½"W
- Shipping Dimensions: 20 1/4 x 20¾" x 23 1/4"
- Hose 2 1/4"D x 5'L
- 115 Volt / 6.5 Amp 750 Watt / 115 CFM / 52 dbA

**Order # 34-2239**

Item	Description	12+	6+	1+
E	Foredom Dust Collector	-	-	\$799.00
	Replacement Filters	\$9.15	\$9.55	\$9.95



E





**BALDOR® POLISHING LATHES**  
Completely enclosed and also uses moisture-resistant copper wiring in the stator winding to provide longer life. Balanced rotor and shaft provides vibration-free and quiet operation. Ball bearings are lubricated for life and sealed to be protected from dust and dirt. Limited three-year manufacturer's warranty. Ships UPS.

Item	Order #	Description	Motor Speed	Spindle	HP/V/Hz	RPM	Model	Shaft Diameter	Shaft Height	Lathe Size	Weight	1+
A	47-4024	One Spindle Lathe	1	1	¾ hp, 115/60 Hz	3,450 RPM	LPL75	5/8"	8"	14½"	48 lbs	\$351.45
	47-4023	One Spindle Lathe	1	1	½ hp, 115/60 Hz	3,450 RPM	LPL50	5/8"	8"	14½"	43 lbs	\$415.00
B	47-4021	Two Spindle Lathe	1	1	½ hp, 115/60 Hz	3,450 RPM	359T	3/8"	5¼"	14½"	36 lbs	\$284.75
	47-4008	Two Spindle Lathe	2	2	¼ hp, 115/60 Hz	3,600/1,800 RPM	340	3/8"	4 1/16"	13 3/8"	32 lbs	\$395.00
	47-4019	Two Spindle Lathe	2	2	¼ hp, 115/60 Hz	3,450/1,725 RPM	353T	3/8"	4 1/16"	14 1/3"	35 lbs	\$425.00
C	47-4022	Two Spindle Lathe	2	2	½ hp, 115/60Hz	3,450/1,725 RPM	380T	3/8"	5¼"	15½"	42 lbs.	\$459.00



**PRO-SERIES POLISHING LATHES**  
This high-base, heavy-duty motor is totally sealed and features permanently lubricated ball bearings. Unique tapered and threaded shaft design virtually eliminate all vibration. Capable of handling up to eight-inch-diameter buffs.

Item	Order #	Description	Motor Speed	Spindle	HP/V	RPM	Shaft Diameter	Shaft Height	Lathe Size	Weight	1+
D	47-4149	Single Spindle Lathe	1	1	¾ hp	3,450	5/8" thread	7"	11"×13"	45 lbs	\$345.30
E	47-4150	Double Spindle Motor		2	¾ hp	3,450	5/8" thread	7"	11"×16"	49 lbs	\$265.75
F	47-4148	Single Spindle Motor	1	1	½ hp	3,450	½" screw	3"	9"×6"	19 lbs	\$184.00
G	47-4147	Double Spindle Motor	2	2	½ hp	3,450	½" screw	3"	12"×6"	22 lbs	\$205.00



**POLISHING LATHES**

Item	Order #	Description	Motor Speed	Spindle	HP/V/Hz	RPM	Model	Shaft Diameter	Shaft Height	Weight	1+
H	47-2701	Two Spindle Lathe	Variable	2	½ hp, 115/60 Hz	4,000	PR90		5¼"	31 lbs	\$715.50
J	47-4020	One Spindle Lathe	1	1	½ hp, 115/60 Hz	3,450	30	5/8" straight	6¾"	36 lbs	\$252.76
K	47-4025	Two Spindle Lathe	2	2	¼ hp, 115/60 Hz	3,450	26	5/8" thread	6¾"	41 lbs	\$315.95

**BENCHTOP POLISHER**

Polisher has pre-lubricated ball bearings and a dust-proof motor housing that makes it virtually maintenance free. The user will not sacrifice quality or speed with this well-balanced precision polisher. Works with standard wheels and buffs up to four inches.

- Two 5/16" tapered spindles
- Two medium abrasive wheels
- Two replacement motor brushes
- 110 volt, 1/6 HP motor. UL listed.

Order #	Description	12+	6+	1+
34-1000	Bench Top Polisher	\$79.48	\$84.15	\$93.50



**FOREDOM® BL 1 LATHE**

High-torque, 1/6 HP lathe with permanent magnet motor sealed in a dust-proof housing. Variable speeds range from 1,800 to 7,000 rpm. No lubrication of ball bearings needed. Comes with two tapered spindles and tools.

Item	Order #	Description	12+	6+	1+
A	34-2000	Foredom BL 1 Lathe	—	—	\$317.07
B	34-2305	Brushes (sold by pair)	\$7.65	\$8.10	\$9.00
C	34-2010	Hood			
		8¾"×4¾"×6½"	\$43.35	\$45.90	\$51.00
D	34-2015	Polishing Hood	—	—	\$299.00
	34-2016	Filters	\$5.95	\$6.30	\$7.00

**Order # 34-20010**

Item	Description	12+	6+	1+
E	Left Tapered Spindle	\$10.58	\$11.04	\$11.50
F	Right Tapered Spindle	\$10.58	\$11.04	\$11.50
G	Chuck Arbor with Key	\$52.13	\$54.39	\$56.66
H	Left Wheel Mandrel	\$14.45	\$15.30	\$17.00
J	Right Wheel Mandrel	\$14.45	\$15.30	\$17.00

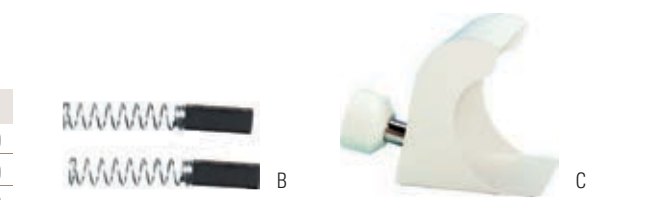

Find added video content on [Stuller.com/VideoCenter](http://Stuller.com/VideoCenter).

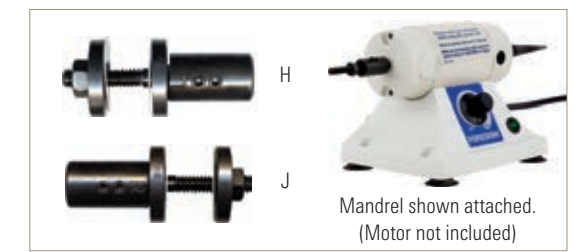

**POLISHING HOOD**

Designed and manufactured to complement dust collectors, the polishing hood maximizes the direction of airflow promoting maximum efficiency. The hood is fabricated out of heavy gauge sheet metal and has a powder-coated finish.

Item	Order #	Description	1+
K	47-4769	Incandescent Polishing Hood w/Light	\$105.95
L	47-4145	Socket for Incandescent Hood	\$10.70
M	47-4146	3" Screen Inlet for Polishing Hood	\$9.60

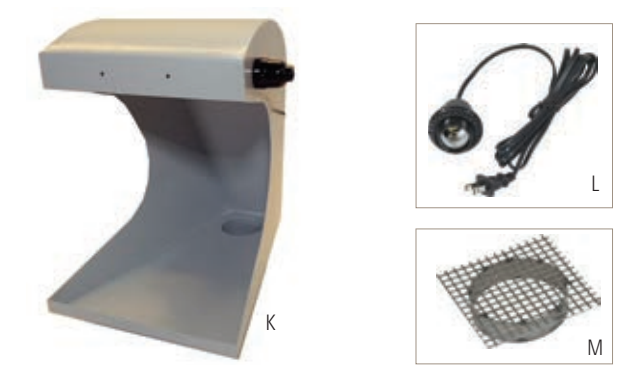

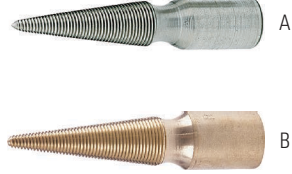

**TAPERED SPINDLES FOR BALDOR® MOTORS**

Spindles are made from tool steel (HR 32-38) and are machined, allowing for a perfect center. This minimizes vibration from the spindles. Spindles are nickel-plated to prevent corrosion. For use with Baldor motors only.

**Order # 47-23040**

Item	Description	Material	Length	12+	6+	1+
A	Right Thread	Steel	¾"	\$8.10	\$8.45	\$8.80
	Left Thread	Steel	¾"	\$8.10	\$8.45	\$8.80
B	Right Thread	Brass	¾"	\$36.52	\$38.11	\$39.70
	Left Thread	Brass	¾"	\$36.52	\$38.11	\$39.70

**TAPERED SPINDLES FOR PRO-SERIES MOTORS**

Tapered spindles for Pro-Series Motors.

**Order # 47-41410**

Item	Description	ID	Length	12+	6+	1+
C	Tapered Spindle Left	½"	3½"	\$7.74	\$8.19	\$9.10
	Tapered Spindle Right	½"	3½"	\$7.74	\$8.19	\$9.10
D	Tapered Spindle Left	⅝"	6"	\$17.62	\$18.38	\$19.15
	Tapered Spindle Right	⅝"	6"	\$17.62	\$18.38	\$19.15



Straight Shaft

**TAPERED SPINDLES WITH SET SCREW FOR STRAIGHT-SHAFT MOTORS**

Individually machined from hardened tool steel, these are precision centered and balanced. Tolerances are within 0.001". Machine-threaded tapered hold buffs are securely centered for maximum performance. Use to mount soft-wheel buffs onto polishing or lapping motors. Fits any straight-shaft motor. Available with right- or left-handed threads and held to shaft by set screws. Ends are pointed, and threads are clear and deep. Made in the USA.

Order #	Description	ID	Length	12+	6+	1+
<b>47-2712</b>	Right Thread	⅝"	4"	\$11.36	\$11.86	\$12.35



**TAPERED SPINDLE**

3" x ½" tapered spindle.

Item	Order #	Description	ID	Length	12+	6+	1+
E	<b>47-2306</b>	Right Thread Tapered Spindle	½"	3"	\$6.42	\$6.80	\$7.55
F	<b>47-2307</b>	Left Thread Tapered Spindle	½"	3"	\$6.42	\$6.80	\$7.55



**SPINDLE FOR QUATRO STAND-UP POLISHING UNIT**

Spindle for Quatro stand-up polishing unit.

Item	Order #	Description	12+	6+	1+
G	<b>47-4233</b>	Right Spindle	\$8.37	\$8.74	\$9.10
H	<b>47-4233</b>	Left Spindle	\$8.37	\$8.74	\$9.10

**WOODEN HUB MANDREL**

Wood adapter includes permanently mounted mandrel mounts on tapered spindle. Features a heavy-duty ¼" diameter screw, holds miniature buffs, felts, brushes, etc., and fits all right-handed threaded spindles.

Order #	Description	12+	6+	1+
<b>47-2600</b>	Wood Hub Mandrel	\$2.07	\$2.16	\$2.25



Mandrel shown attached. (Motor not included).

**TAPERED CHUCK FOR BRUSHES**

Use with tapered spindle on polishing motors. Fits brushes with ⅛" holes. Can be threaded onto the hardened steel taper, which in turn can be threaded onto a standard tapered spindle.

**Order # 47-25800**

Item	Description	12+	6+	1+
A	Right-Handed	\$3.17	\$3.31	\$3.45
B	Left-Handed	\$3.17	\$3.31	\$3.45

Mandrel shown attached. (Motor not included).



**PLASTIC HUB MANDREL**

Plastic hub mandrels designed to fit brushes with ⅛" arbor hole.

**Order # 47-26080**

Item	Description	12+	6+	1+
C	Right-Handed	\$6.59	\$6.98	\$7.75
D	Left-Handed	\$6.59	\$6.98	\$7.75



Chucks and mandrels shown attached. (Motors not included).

**HANDLE WITH CHUCK**

Wooden handle features and bored and reinforced end. Small wheels and burs can be used on larger polishing motors by threading onto tapered spindles. Chuck opens from 0.085" to 0.128". Accommodates ⅜" and ½" mandrels.

**Order # 37-76000**

Description	Length	12+	6+	1+
Handle with Chuck	3½"	\$8.08	\$8.55	\$9.50
Replacement Chuck		\$2.85	\$3.02	\$3.35



**TAPERED WHEEL ADAPTER**

Accessory for two-inch and three-inch radial bristle discs. Discs mount on this adapter, which fits on standard tapered spindle for bench motors.

**Order # 10-91620**

Item	Description	ID	Color	12+	6+	1+
E	Right Adapter	⅝"	Black	\$1.95	\$2.06	\$2.29
F	Left Adapter	⅝"	Gray	\$1.95	\$2.06	\$2.29



**TAPERED SPINDLE ADAPTERS**

This tapered spindle adapter is to be used on six-inch wheels with center holes that measure one inch.

Order #	Description	ID	12+	6+	1+
<b>10-8208</b>	Adapter	1"	\$5.33	\$5.56	\$5.79







**DURSTON VARIABLE-SPEED SUPER LAPPER**

Tapered spindle design operating at a 45 degree angle which is adjustable to suit your needs to provide optimum visibility and accessibility. Manufactured for both angular and flat surfaces producing outstanding results.

Order #	Description	1+
47-7011	Variable-Speed Super Lapper	\$1,249.00

**SPLIT LAP**

Multi-laminated and flexible, these impregnated cotton split laps feature aluminum-oxide abrasive grains. Smooth, controlled, cool grinding action produces a consistent finish on most metals.

Order # 17-50110

Item	Grit	OD	Thickness	ID	12+	6+	1+
A	180	6"	1/4"	3/8"	\$36.57	\$38.16	\$39.75
B	120	6"	1/4"	3/8"	\$36.57	\$38.16	\$39.75



**MARATHON SPLIT LAP**

Each wheel is balanced with holes in the precise center to ensure smooth operation. Perfectly concentric slits provide outstanding visibility of the item being polished.

Order # 17-94600

Item	Grade	OD	Thickness	12+	6+	1+
C	Medium	6"	1/2"	\$27.33	\$28.94	\$32.15
D	Hard	6"	1/2"	\$31.15	\$32.99	\$36.65
E	Rock Hard	6"	1/2"	\$33.75	\$35.73	\$39.70
F	Flint Hard	6"	1/2"	\$35.53	\$37.62	\$41.80



**PARAMOUNT FELT SPLIT LAPS**

These are the industry standard. All come with pinhole centers.

Order # 17-95600

Grade	OD	Thickness	12+	6+	1+
Medium	6"	1/2"	\$34.98	\$37.04	\$41.15
Medium	6"	1/2"	\$36.81	\$38.97	\$43.30
Hard	6"	1/2"	\$36.81	\$39.92	\$44.35
Rock Hard	6"	1/2"	\$50.28	\$52.46	\$54.65
Flint Hard	6"	1/2"	\$49.77	\$51.94	\$54.10



**SILICONE SIX-INCH SPLIT LAPS**

Very clean. No rouge. Excellent finish.

Order # 17-50250

Description	Grit	12+	6+	1+
Pre-Polish	100	\$57.80	\$61.20	\$68.00
Polish	180	\$57.80	\$61.20	\$68.00

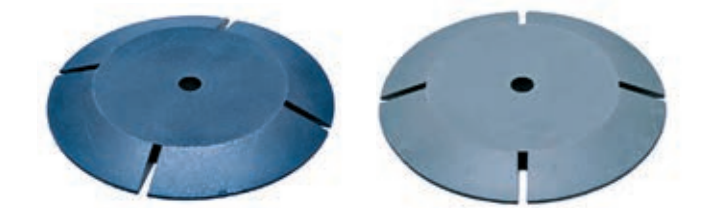

**SPANISH FELT SPLIT LAP WHEEL**

These high-grade wheels are excellent for all-purpose polishing and buffing. Made in the USA.

Order #	Description	Diameter	Thickness	12+	6+	1+
17-5000	Split Lap	4"	1/2"	\$16.24	\$16.94	\$17.65



**STULLER SPLIT LAP MACHINE WITH TABLE**

Tapered spindle lapping machine has a 45-degree-angle design to provide optimum visibility. Dual three-inch flanges allow the introduction of two-sided dust collection. Spindle included. Motor HP: 1/2

Item	Order #	Description	WxLxH	12+	6+	1+
A	47-7006	Lapping Machine w/Table 16"x24"x18"		-	-	\$845.00
B	47-4140	Replacement Spindle (Left) (5/8" ID x 6" L)		\$15.69	\$16.37	\$17.05
C	47-7000	Lapping Machine	24"x14"x38"	-	-	\$379.00
D	47-7000	Enclosed Hood	16"x16 1/2"x14"	-	-	\$299.00





A. This is a complete solution for grinding, high-precision honing, sharpening, and polishing. Sharpen carbide and grind exotic metals with 3M™ Diamond Abrasives. Excellent for any metal or wood applications.

The included Cushion Pads allow higher accuracy and longer abrasive life. The brush permits polishing of crevices and contoured areas on any metal.

- 12 Ninja SEE-THRU™ Backpads
- 9 Ninja Cushion Pads: 3M™ Bumpon™
- 3M™ Microfinishing Diamond™: 74, 45, 30, 20 Micron
- 3M™ Purple Ceramic™: 80, 120, 220 Grit
- 3M™ Trizact™: 35, 20, 10, 5 Micron
- Ninja™ SEE-THRU™ felt disc
- Jooltool™ Polishing Compound
- 3M™ 3" Bristle Brush: 1 Micron (polishing)
- Instructional DVD

B. This is the ideal solution for grinding, high precision honing, sharpening, and polishing. Great for metal and wood applications, the included Cushion Pads allow higher accuracy and longer abrasive life. The brush permits polishing of crevices and contoured areas on any metal.

- 4 Ninja SEE-THRU™ Backpads
- 3 Ninja Cushion Pads: 3M™ Bumpon™
- 3M™ Purple Ceramic™: 80, 120, 220 Grit
- 3M™ Trizact™: 35, 20, 10, 5 Micron
- Ninja™ SEE-THRU™ felt disc
- Jooltool™ Polishing Compound
- 3M™ 3" Bristle Brush: 1 Micron (polishing)
- Instructional DVD

C. Perfect as a start-up package, this kit includes grinding, sharpening, and polishing abrasives. Great for metal and wood applications.

- 3 Ninja SEE-THRU™ Backpads
- 3M™ Purple: 80, 120, 220 Grit
- 3M™ Trizact™: 35, 20, 10, 5 Micron
- Ninja™ SEE-THRU™ felt disc
- Jooltool™ Polishing Compound
- Instructional DVD

### THE JOOLTOOL FINISHING SYSTEM

The JoolTool is a revolutionary, compact, multifunctional tool perfect for grinding, sharpening, sanding, deburring, polishing, and much more. The JoolTool will help hobbyists and industrial professionals conquer any job. And in most instances, they can replace the need for conventional bench grinders, belt sanders, sharpeners, etc. Why spend needlessly when the JoolTool can do it all.

- Speed: variable - 500 to 5,000 RPM
- HP: 1/20 Horsepower
- Voltage: 110 DC
- Vent: 1.5" diameter (for optional vac hookup)
- Max. Wheel Diameter: 3" (Recommended)
- Dimensions: 12" tall x 8" diameter
- Fuse Protected: 5 amp (replaceable)
- Manufactured: USA

Item	Order #	Description	12+	6+	1+		
A	47-5296	Master Jewelry Kit	\$659.99	—	—		
B	47-5299	Pro Jewelry Kit	\$549.99	—	—		
C	47-5300	Jewelry Kit	\$489.99	\$489.99	\$489.99		
ACCESSORIES		Description	Micron	Per Pack	12+	6+	1+
	47-5312	Combo Kit		(Each)	\$70.95	\$68.11	\$65.27
	47-5305	Green Disk	A-35 μ	(6 Pack)	\$22.20	\$21.31	\$20.42
	47-5306	Red Disk	A-20 μ	(6 Pack)	\$20.35	\$19.54	\$18.72
	47-5307	Blue Disk	A-10 μ	(6 Pack)	\$20.35	\$19.54	\$18.72
	47-5308	Orange Disk	A-5 μ	(6 Pack)	\$20.35	\$19.54	\$18.72
		Description	Grit	Per Pack	12+	6+	1+
	47-5304	Purple Disk	220	(6 Pack)	\$20.20	\$19.39	\$18.58
	47-5309	Purple Asst.	80, 120, 220	(3 Each)	\$42.10	\$40.42	\$38.73
	47-5310	Trizact Asst.	35, 20, 10, 5	(3 Each)	\$48.00	\$46.08	\$44.16
		Description	Per Pack	12+	6+	1+	
	47-5324	3M Scotchbrite Ninja Very fine, fine, MediumCoarse, Medium, Fine	(Set of 3)	\$82.45	\$74.20	\$70.08	
	47-5301	Black Pad	(3 Pack)	\$42.65	\$40.94	\$39.24	
	47-5319	3 Buff & Polish Felt	(Each)	\$39.75	\$35.78	\$33.79	
	47-5302	80 Grit 3M Purple Ninja Disc	(6 Pack)	\$17.95	—	—	
	47-5297	Cushion Pad	(Each)	\$35.35	\$31.82	\$30.05	

### ROUGES FOR GOLD AND SILVER PRE-FINISHING

#### TRIPOLI

Coarse cutting compound to remove scratches and surface imperfections. All-purpose tripoli cuts similarly to regular tripoli but leaves a brighter finish. Platinum Tripoli is specially formulated to remove scratches from platinum, chromium, stainless steel, and other hard metals.

Order # 47-32500

Item	Description	Grade	12+	6+	1+
A	1 lb Tripoli Tube	Aggressive	\$2.85	\$2.98	\$3.10
B	1 lb All-Purpose Tripoli Tube	Extra Fine	\$4.28	\$4.46	\$4.65
C	1 lb Platinum Tripoli Tube	Aggressive	\$3.17	\$3.31	\$3.45



#### GRAYSTAR

Dry, aggressive compound for removing scratches and imperfections. Works well on brass, gold, silver, and stainless steel, leaving a uniform finish. Made of very fine uniform abrasives, produces good cut with no mild scratches. May be used for cut and color as one step.

Item	Order #	Description	Grade	Grit	12+	6+	1+
D	47-3297	1 lb Bar	Medium Coarse	800	\$4.28	\$4.46	\$4.65



#### TRIPOLI

Superior cutting and color compound for soft metals such as gold, silver, and brass. 600 grit.

Order # 47-32800

Item	Description	Grade	12+	6+	1+
E	1 lb Luminescence Tripoli Tube	Fine	\$3.96	\$4.13	\$4.30
F	1 lb White 3XXX Bar	Fine	\$2.39	\$2.50	\$2.60
G	1 lb White 4XXXX Bar (finer abrasives)	Extra Fine	\$2.02	\$2.11	\$2.20



#### BOBBING COMPOUND

Aggressive on soft metals such as gold, silver, aluminum, and brass. Adheres extremely well to buffs when using laps and bristle brushes. Fast and heavy cutting.

Order # 47-32900

Item	Description	Grade	Grit	12+	6+	1+
H	1 lb Tube	Medium	600	\$2.67	\$2.78	\$2.90
J	1 lb Bar	Medium	600	\$2.39	\$2.50	\$2.60



#### TRIPOLI

Fast cutting on all non-ferrous metals. Formulated to produce excellent results with quick and easy cleanup.

Item	Order #	Description	Grade	Grit	12+	6+	1+
K	47-3257	2 1/4 lb Bar	Coarse	240	\$3.49	\$3.69	\$4.10







### ROUGES FOR GOLD AND SILVER FINISHING

#### WATER SOLUBLE ROUGE

Water-soluble polishing rouges are formulated to produce excellent results with quick and easy cleanup.

Order # 47-32740

Item	Description	Grade	Grit	Color	12+	6+	1+
A	½ lb Bar	Medium Fine	6000	Green	\$9.27	\$9.81	\$10.90
B	½ lb Bar	Medium	1200	Yellow	\$2.58	\$2.69	\$2.80



#### GREEN ROUGE

Specially formulated for silver, stainless steel, platinum, white gold, and rhodium, these are sold in tubes or bars. Produces a high luster for a final finish. Clean working and leaves little residue.

Order # 47-32100

Item	Description	Grade	12+	6+	1+
C	8 oz Tube	Medium Fine	\$3.40	\$3.69	\$4.10
D	16 oz Tube	Medium Fine	\$2.39	\$2.50	\$2.60
E	3 oz Bar	Medium Fine	\$5.57	\$5.81	\$6.05



### ROUGES FOR GOLD AND SILVER FINAL FINISHING

#### WATER SOLUBLE ROUGE

Industry standard for a deep luster, final finish for gold, silver, and brass, these are completely free of grit or other coarse matter. Provides a mirror finish on metal after prior cut down.

Order # 47-32220

Item	Description	Grade	Grit	Color	12+	6+	1+
F	1 lb Bar	Extra Fine	1500	Red	\$5.61	\$5.86	\$6.10
G	1 lb Bar	Fine	1200	Blue	\$3.36	\$3.50	\$3.65

#### RED ROUGE

Industry standard for a deep luster, final finish for gold, silver, and brass, these are completely free of grit or other coarse matter. Provides a mirror finish on metal after

Order # 47-32300

Item	Description	Grade	12+	6+	1+
H	8 oz Tube	Extra Fine	\$4.60	\$4.80	\$5.00
J	16 oz Tube	Extra Fine	\$4.73	\$5.13	\$5.70



#### BLACK ROUGE

Produces a rich, darker luster on white gold, silver, and platinum. Highly recommended for silver.

Order # 47-32000

Item	Description	Grade	12+	6+	1+
K	8 oz Tube	Fine	\$3.96	\$4.13	\$4.30
L	16 oz Tube	Fine	\$4.65	\$4.85	\$5.05

#### YELLOW ROUGE

Excellent for an ultra-bright final finish on yellow gold and hard metals. Less greasy and cleaner to use than most other rouges.

Order # 47-32700

Item	Description	Grade	12+	6+	1+
M	8 oz Tube	Extra Fine	\$3.24	\$3.51	\$3.90
N	16 oz Tube	Extra Fine	\$4.77	\$5.18	\$5.75

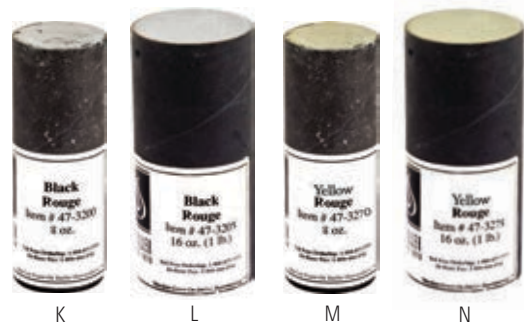

### ROUGES FOR TITANIUM FINISHING

#### TITANIUM POLISH

Titanium polish in different grades for use on your titanium metals.

Order # 47-32990

Item	Description	12+	6+	1+
A	16 oz TP-100 Bar	\$18.23	\$19.31	\$21.45
B	16 oz TP-200 Bar	\$20.10	\$21.29	\$23.65
C	16 oz TP-300 Bar	\$11.43	\$12.11	\$13.45
D	16 oz TP-400 Bar	\$15.64	\$16.32	\$17.00

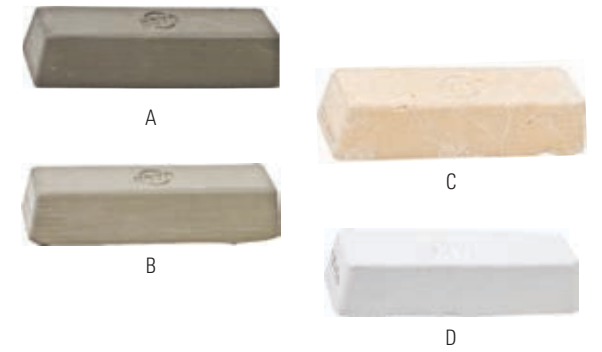

### ROUGES FOR PLATINUM FINISHING

#### PICASSO BLUE

Ultra-bright finish for platinum and gold.

Item	Order #	Description	Color	12+	6+	1+
E	47-3246	¼ lb Bar	Picasso Blue	\$14.15	\$14.99	\$16.65



#### ULTRA BLUE POLISH

For platinum and other white metals.

Item	Order #	Description	Grit	Color	12+	6+	1+
F	47-3247	1 lb Bar	1000	Light Blue	\$4.21	\$4.46	\$4.95



#### PLATINUM COMPOUNDS

Specially formulated compounds for platinum polishing.

Blue Platinum removes light scratches and prepares for final polishing of platinum.

Item	Order #	Description	Grit	Color	12+	6+	1+
G	47-3271	¼ lb Bar	1000	Blue	\$10.29	\$10.89	\$12.10



#### PLATINUM POLISH

Water-soluble polishing rouges are formulated to produce excellent results with quick and easy cleanup.

Item	Order #	Description	Grit	Color	12+	6+	1+
H	47-3380	1 lb Bar	800	White	\$5.08	\$5.72	\$6.35



#### BRIGHT-WHITE PLATINUM

Breakthrough for platinum polishing, this white compound is much easier than existing compounds. Easy cleanup and leaves little residue.

Item	Order #	Description	Grit	12+	6+	1+
J	47-3266	¼ lb bar, Polishing Compound	800	\$5.52	\$5.76	\$6.00



#### PLATINUM POLISH

Works extremely well on platinum and gold by cutting the polishing time in half. It is oil-less and greaseless. Tried and tested at Stuller.

Item	Order #	Description	Grit	12+	6+	1+
K	47-3385	1 lb bar, Platinum Polish	1000	\$4.73	\$5.40	\$6.75



See page 443 for our complete line of pre-finishing rouges.



A



B



C



D



E



F

### ROUGES FOR PLATINUM FINAL FINISHING

#### PICA PINK

A selected grade of polishing compound formulated for ultra-bright finishing of platinum. Uniformly blended and manufactured under strict quality control. Exceptional adherence to buffs, brushes, or felts.

Item	Order #	Description	Grade	Color	12+	6+	1+
A	47-3245	¼ lb Bar	Extra Fine	Pica Pink	\$17.30	\$18.32	\$20.35

#### PLATINUM COMPOUNDS

Specially formulated compounds for platinum polishing. Provides the final polish of platinum

Item	Order #	Description	Color	12+	6+	1+
B	47-3267	16oz. Bar	Pumpkin	\$10.49	\$10.94	\$11.40
C	47-3384	16oz. Bar	Yellow	\$3.87	\$4.10	\$4.55

#### CARROT ROUGE

Excellent for platinum, a crocus polishing compound that is an excellent alternative to rouge. This compound has been tested extensively and found to leave a superior finish on platinum. Can also be used on hard plastics and epoxy.

Item	Order #	Description	Color	12+	6+	1+
D	47-3140	¼ lb Bar	Carrot Rouge	\$17.16	\$17.90	\$18.65

#### WHITE ROUGE

High luster on platinum, white gold, chrome, and stainless steel, this rouge is packaged in easy-to-use, clean, peel-away tubes. 800 grit.

Item	Order #	Description	Grade	12+	6+	1+
E	47-3260	8 oz White Rouge Tube	Extra Fine	\$4.09	\$4.27	\$4.45
F	47-3265	16 oz White Rouge Tube	Extra Fine	\$5.38	\$5.62	\$5.85

#### FABULUSTRE® AND ZAM® POLISHING COMPOUNDS

Fabulustre - Provides a high luster finish on all types of precious metals. Greaseless, dry, not dusty, which allows for faster clean-up. For use in final buffing.

##### Order # 47-31200

Item	Description	12+	6+	1+
G	¼ lb Fabulustre Tube	\$4.09	\$4.27	\$4.45
H	1 lb Fabulustre Tube	\$6.35	\$6.89	\$7.65
J	¼ lb Zam Tube	\$3.77	\$3.94	\$4.10
K	1 lb Zam Tube	\$6.72	\$7.01	\$7.30



G



H



J



K

#### ROUGE INFORMATION

Stuller has received several questions about our polishing compounds. The most often asked is whether our compounds are water-soluble. When discussing polishing compounds, the term is sometimes technically incorrect. Stuller's compounds in the tear-away tubes contain similar vegetable and animal fats; however, our compounds are highly saponifiable. Saponifiable means that they will break down or mix with alkalis or soap resulting in easier cleanup. Stuller polishing compounds are made from the highest-quality raw materials. Our compounds are softer than many others and tend to be more aggressive. This means that less compound is required on the buff. Applying too much compound on your buff is counterproductive, expensive, and may result in the surface of the piece appearing cloudy. Remember the old saying, "A little dab will do you." You'll find that Stuller offers you a longer-lasting polishing compound with easier cleanup that will save you money all the way around.

#### DIALUX POLISHING BARS

A select type of super abrasive uniformly blended with a carrier wax. These compounds have special features that allow good adhesion to the fibers of brushes, buffs, or felts. Only minimal quantities need to be used. Bar size 4" x 1¼" x 1⅛".

**Red:** Super finishing composition for gold

**Orange:** Produces a high luster on soft metals

**Yellow:** Gives a bright finish to soft brass, bronze, and copper

**Green:** Super finishing composition for hard metals (chrome and platinum)

**Gray:** Finishing composition for stainless steel

**White:** Finishing for all metals and some plastics in the dental range

**Blue:** Super finishing for all metals and plastics in the dental range

##### Order # 47-31500

Item	Description	Grit	Color	12+	6+	1+
A	¼ lb Bar	400	Orange	\$4.89	\$5.18	\$5.75
B	¼ lb Bar	600	Yellow	\$4.89	\$5.18	\$5.75
C	¼ lb Bar	800	Red	\$4.89	\$5.18	\$5.75
D	¼ lb Bar	2000	Green	\$4.89	\$5.18	\$5.75
E	¼ lb Bar	1200	Gray	\$4.89	\$5.18	\$5.75
F	¼ lb Bar	1500	White	\$4.89	\$5.18	\$5.75
G	¼ lb Bar	1800	Blue	\$4.89	\$5.18	\$5.75



#### WHITE COMPOUNDS

A selected grade of polishing compound formulated for ultra-bright finishing of platinum. Uniformly blended and manufactured under strict quality control. Exceptional adherence to buffs, brushes, or felts. Available in five different grades to achieve surfaces from matte to super shine. Made in Japan.

**Medium Cut-1500:** For removal of light scratch marks

**Fine-Cut-4000:** To further improve the surface prior to final finishing

**Extra Shine-6000:** Enhances the surface to exhibit a bright finish

**Super Shine-8000:** Provides a very high luster and bright mirror finish

**First Cut-800:** For initial smoothing of waviness and roughness

##### Order # 47-32410

Item	Description	Grit	Color	12+	6+	1+
H	1 lb Medium Cut	1500	White	\$32.34	\$34.25	\$38.05
J	1 lb Fine-Cut	4000	White	\$34.47	\$36.50	\$40.55
K	1 lb Extra Shine	6000	White	\$34.47	\$36.50	\$40.55
L	1 lb Super Shine	8000	White	\$37.10	\$39.29	\$43.65
M	1 lb First Cut	800	Gray	\$22.36	\$23.33	\$24.30



#### KOYO PLATINUM COMPOUNDS

A finishing compound manufactured from carefully graded abrasives, blended with additives to give high reflective surfaces to non-ferrous metals and stainless steels.

• K-1 Green: General purpose for preliminary finishing applications

• K-2 Green: Intermediate stage finishing compound

• Alox-5 White: For final finish, to achieve a distinctive luster

##### Order # 47-32610

Item	Description	Color	12+	6+	1+
N	K-1	Green	\$26.86	\$28.44	\$31.60
P	K-2	Green	\$11.36	\$11.86	\$12.35
Q	Alox-5	White	\$23.16	\$24.53	\$27.25
R	Alox-5	White	\$8.54	\$9.05	\$10.05







**MERARD POLISHING SOLUTION**

Stuller offers you a polish that has been tried, tested, and used in our own manufacturing processes. The Merard brand of polish has outperformed all other polishes it has been put up against. Stuller has taken it one step further by matching the proper buff to the polish. Exclusively from Stuller, we bring you polishing solutions from Merard, the industry leader in polishing compounds and buffs. Top manufacturers of fine luxury watches have now implemented this polishing solution into their processes especially for gold and stainless steel watch cases. Now it is available to you. Step 1- Avivor (47-3223) polish in conjunction with TPB buff (47-3228) Step 2- Oras (47-3225) polish in conjunction with STV buff (47-3229) For best results use a variable speed motor (47-2701) at 1800 RPM with light pressure.

Item	Order #	Description	Volume	12+	6+	1+
A	47-3223	Avivor	8 oz	\$13.89	\$14.50	\$15.10
B	47-3225	Oras	8 oz	\$13.89	\$14.50	\$15.10

**LUXOR® POLISHING ROUGE**

**Luxor Pink** has 6.5 micron grit and is used for preparation (high) and can be used on all metals, but it is an especially excellent pre-polish for platinum.

**Luxor White** has .3 micron grit and is used for fine polishing and finishing and can be used with steel, stainless steel, silver, gray gold, white gold, and platinum.

**Luxor Yellow** has .5 micron grit and is used for finishing and can be used on all kinds of gold, steel and stainless steel.

**Luxor Orange** has .1 micron grit and is used for super finishing and can be used on precious metals and lacquers.

With the Luxor line you will

- Save time and use less
- Have a cleaner piece with fewer residues
- Have a cleaner work area

Use with 17-5565. They are smaller bars because you use less and they are easier to use.

**Order # 47-3224**

Description	Micron	Volume	12+	6+	1+
Pink	6.5 μ	8 oz	\$9.25	\$9.65	\$10.05
White	0.3 μ	8 oz	\$9.25	\$9.65	\$10.05
Yellow	0.5 μ	8 oz	\$9.25	\$9.65	\$10.05
Orange	0.1 μ	8 oz	\$9.25	\$9.65	\$10.05



**LUXOR® BUFF AND POLISHING KIT**

Luxor buff and polishing kit consists of the four Luxor polishes: pink, white, yellow, and orange. These are ultra high-quality polishes. Also the kit comes with the four-inch TPB cotton buff and a four-inch STV cotton buff.

Order #	Description	12+	6+	1+
47-3221	4 Polish, 2 Buff Ultimate Polishing Kit	\$46.41	\$48.43	\$50.45



**HIGH-QUALITY BUFFS**

**LUXOR® MOC2 BUFFS**

The softest Luxor buff is made of white flannel scraped on two sides and extremely versatile. This buff can be used with Avivor, Oras, as well as Luxor white, yellow, and orange polishing compounds. This buff is especially effective on gold, titanium, platinum, and silver jewelry.

**Order # 47-3227**

Grade	Diameter	Thickness	12+	6+	1+
Extra Soft	6"	1"	\$20.84	\$21.74	\$22.65
Extra Soft	4"	½"	\$14.17	\$14.78	\$15.40

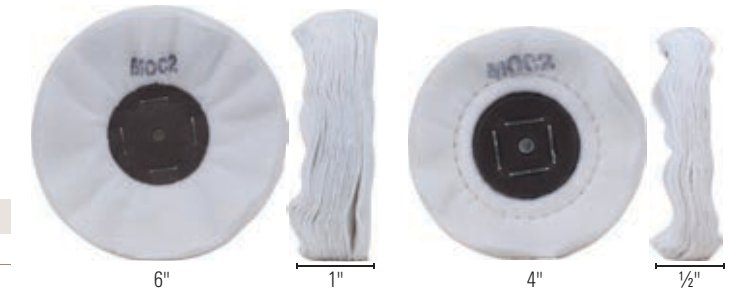

**LUXOR® TPB BUFFS**

A bleached shirting material watch polishing buff is used in combination with Avivor as the first step in the finest polishing process for watch cases. Also used with Luxor white for more delicate white metal jewelry pieces (stainless steel, silver, white gold, and platinum)

**Order # 47-3228**

Grade	Diameter	Thickness	12+	6+	1+
Medium	6"	1"	\$33.17	\$34.61	\$36.05
Medium	4"	½"	\$14.54	\$15.17	\$15.80

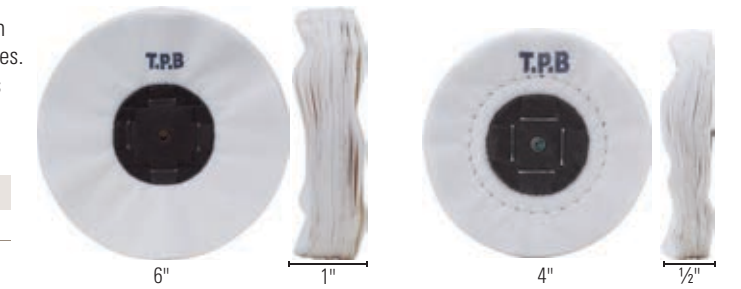

**LUXOR® STV BUFFS**

An extremely versatile buff of glazed Percal material. It is recommended for the second step of fine watch case polishing in conjunction with Oras. Also used with Luxor white for white metal jewelry pieces, Luxor yellow for gold and steel, Luxor orange for precious metals, and even suitable for use with Avivor.

**Order # 47-3229**

Grade	Diameter	Thickness	12+	6+	1+
Soft	6"	1"	\$28.43	\$29.66	\$30.90
Soft	4"	½"	\$14.72	\$15.36	\$16.00

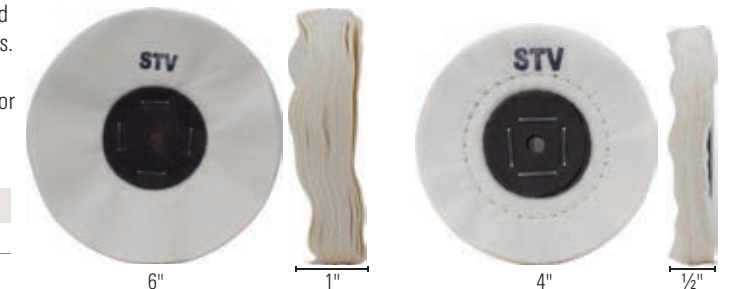

**LIQUID POLISH FOR VIBRATORY FINISHING**

This revolutionary liquid polish is used with dry, untreated walnut shell. Use approximately two tablespoons of liquid in a one-cubic-foot tumbler. Tumble for six to eight hours.

**Order # 47-3226**

Item	Description	Color	Volume	12+	6+	1+
A	Step 1: Fine Polish	White	1 kg	\$18.91	\$19.73	\$20.55
B	Step 2: Super Fine Polish	Orange	1 kg	\$21.30	\$22.22	\$23.15
C	Polishing Cream		1 kg	\$18.54	\$19.34	\$20.15





A



B



C



D

**BUFF KITS**

Stuller offers premium polishing kits that are perfectly suited for your shop's needs. We've drawn from our own production experience. These kits include the same materials we use every day in our production area.

**A. STARTER BUFF KIT**

This kit contains a selection of premium buffs and compounds that are perfect for gold and silver items. Includes 17-7227 yellow buff, 17-7516 stitched muslin, 17-7726 loose buff, 17-7516 GrayStar, 47-3274 green rouge, 47-3236 red rouge

**B. STARTER BUFF KIT**

This kit contains a selection of premium buffs and compounds that are perfect for gold and silver items. Includes 17-7227 yellow buff, 17-7516 stitched muslin, 17-7726 loose buff, 17-7516 GrayStar, 47-3274 green rouge, 47-3236 red rouge

**C. AND D. MINIATURE BUFF ASSORTMENTS**

Contains buffs and mandrels to be used on flex shafts. Two 3/32" mandrels, chamois buff, muslin wheel, felt cone, and three wheels are packaged in a plastic box.

Item	Order #	Description	12+	6+	1+
A	17-7255	Starter Buff Kit	\$24.35	\$25.79	\$28.65
B	17-7255	Platinum Buff Kit	\$58.27	\$61.70	\$68.55
C	17-1270	130 pc Buff Assortment	\$60.21	\$62.83	\$65.45
D	17-1260	6 pc Miniature Buff Assortment	\$5.98	\$6.24	\$6.50

**ORANGE BUFFING WHEELS**

Long-lasting, orange buffing wheels are best used for bobbing compounds and platinum tripoli. Thread count 86 x 80.

Order # 17-56070

OD	Rows	Ply	12+	6+	1+
3"	3	30	\$2.64	\$2.79	\$3.10
4"	3	50	\$3.61	\$3.83	\$4.25
5"	3	50	\$5.87	\$6.21	\$6.90
5"	3	60	\$7.64	\$7.97	\$8.30
6"	4	50	\$8.42	\$8.78	\$9.15
6"	4	60	\$9.25	\$9.65	\$10.05



**PRE-FINISHING BUFFS**

**A. PURPLE TREATED MUSLIN BERRY BUFFS**

Stiff, chemically treated, fine-weave muslin buffs with leather centers are ideal for aggressive compounds and great for platinum.

Order # 17-72500

Description	OD	Rows	Ply	12+	6+	1+
Knife-Edge	4"	7	12	\$3.77	\$3.94	\$4.10
Knife-Edge	6"	10	12	\$4.19	\$4.37	\$4.55
Square-Edge	4"	3	40	\$4.28	\$4.46	\$4.65
Square-Edge	5"	3	40	\$4.83	\$5.04	\$5.25
Square-Edge	6"	4	50	\$6.49	\$6.77	\$7.05
Square-Edge	6"	0	50	\$7.22	\$7.54	\$7.85

**B. CHEMKOTE-TREATED MUSLIN BUFFS — SQUARE-EDGE STITCHED**

Yellow, 5/8" thick muslin buffs are chemically treated to make them last longer than white muslin. Made from fine-weave muslin with combed edges and shellac center, these are used for cutdown procedures on heavy, rough work.

Order # 17-55330

OD	Rows	Ply	12+	6+	1+
3"	3	30	\$2.64	\$2.79	\$3.10
4"	3	40	\$2.64	\$2.97	\$3.30
4"	3	50	\$3.69	\$4.01	\$4.45
5"	3	45	\$4.16	\$4.68	\$5.20
5"	3	60	\$4.77	\$5.18	\$5.75
6"	4	50	\$5.20	\$5.85	\$6.50
6"	4	60	\$7.65	\$8.10	\$9.00

**C. CHEMKOTE-TREATED MUSLIN BUFF — SQUARE-EDGE LOOSE**

Leather center.

Order # 17-72000

OD	Rows	Ply	12+	6+	1+
4"	1	20	\$1.66	\$1.73	\$1.80
4"	3	20	\$2.02	\$2.11	\$2.20
6"	1	20	\$2.85	\$2.98	\$3.10
6"	4	50	\$6.08	\$6.44	\$7.15

**D. CHEMKOTE-TREATED MUSLIN BUFFS — KNIFE-EDGE**

Leather center.

Order # 17-56030

OD	Rows	Ply	12+	6+	1+
3"	4	9	\$2.34	\$2.48	\$2.75
4"	6	12	\$2.86	\$3.11	\$3.45
5"	7	12	\$3.78	\$4.10	\$4.55
6"	9	12	\$3.91	\$4.14	\$4.60



A

A



B



C



D





A

### FINISHING BUFFS

#### A. FINEX COMBED MUSLIN BUFFS

Finex muslin has a very tight weave and is very soft. Excellent for use on all rouges, these buffs are chemically treated for longer life and manufactured of fine-weave muslin. All buffs can be used on a tapered spindle. An excellent finishing buff to be used with red rouge. Leather center.

Order # 17-72450

OD	Rows	Ply	12+	6+	1+
5"	3	20	\$3.96	\$4.13	\$4.30
3"	3	35	\$2.53	\$2.75	\$3.05
4"	3	30	\$2.64	\$2.97	\$3.30
5"	3	45	\$4.40	\$4.95	\$5.50
6"	4	50	\$6.36	\$7.16	\$7.95
4"	3	50	\$3.40	\$3.69	\$4.10
5"	3	50	\$4.80	\$5.40	\$6.00
6"	4	60	\$7.80	\$8.78	\$9.75

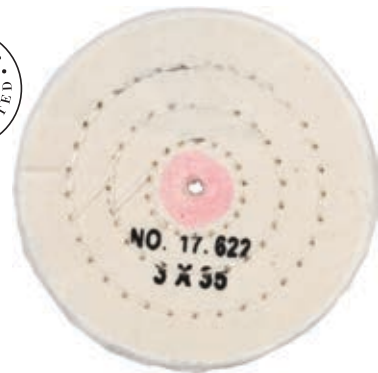

B

#### B. FINEX COMBED MUSLIN BUFFS

Finex combed muslin buff features a shellac center. Finex muslin has a very tight weave and is very soft. Excellent for use on all rouges.

Order # 17-62350

OD	Rows	Ply	12+	6+	1+
3"	3	35	\$1.70	\$1.85	\$2.05
4"	4	30	\$2.28	\$2.48	\$2.75
4"	4	50	\$2.86	\$3.11	\$3.45
5"	3	45	\$3.20	\$3.47	\$3.85
5"	5	55	\$4.03	\$4.37	\$4.85
5"	3	50	\$4.04	\$4.55	\$5.05
6"	4	50	\$4.98	\$5.40	\$6.00
6"	6	60	\$5.35	\$5.81	\$6.45

#### C. MUSLIN BUFFS

All-purpose buffs are used for initial polishing. Excellent for use with tripoli and bobbing compounds. Shellac-hardened centers with stitched, cotton-flannel, these buffs have soft, thick material for general polishing. Excellent for use on gold and

Order # 17-20050

OD	Rows	Ply	12+	6+	1+
4"	3	30	\$3.61	\$3.92	\$4.35
5"	3	30	\$4.65	\$5.04	\$5.60
6"	4	30	\$6.38	\$6.75	\$7.50
4"	3	42	\$2.64	\$2.79	\$3.10
5"	3	45	\$3.48	\$3.92	\$4.35
6"	4	50	\$5.04	\$5.67	\$6.30



Cotton-Flannel



All-Purpose

### FINAL FINISHING BUFFS

#### A. FINEX KNIFE-EDGE MUSLIN BUFFS

Excellent for polishing areas where conventional buffs cannot reach. Stitching makes edge firm and helps maintain buff shape. Leather center.

Order # 17-64300

OD	Rows	Ply	12+	6+	1+
3"	3	9	\$2.66	\$2.88	\$3.20
4"	5	12	\$4.32	\$4.51	\$4.70
5"	7	12	\$4.03	\$4.37	\$4.85
6"	9	12	\$3.92	\$4.41	\$4.90

#### B. FINEX COMBED MUSLIN BUFFS

Finex muslin has a very tight weave and is very soft. Excellent for use on all rouges.

Order # 17-77190

OD	Rows	Center Type	12+	6+	1+
4"	50	Leather	\$4.51	\$4.77	\$5.30
5"	50	Leather	\$4.76	\$5.44	\$6.80
6"	50	Leather	\$5.50	\$6.28	\$7.85

#### C. FINEX COMBED WHITE MUSLIN BUFFS

Finex fine-combed, unstitched buffs with hard, plastic center.

Order # 17-71600

OD	Rows	Center Type	12+	6+	1+
3"	36	Plastic	\$2.85	\$2.98	\$3.10
4"	36	Plastic	\$3.50	\$3.65	\$3.80
5"	54	Plastic	\$4.69	\$4.90	\$5.10
6"	54	Plastic	\$5.84	\$6.10	\$6.35

#### D. LEAD CENTER MUSLIN BUFFS

Loose muslin buffs with lead centers are boxed to thread onto tapered spindles. Made in the USA.

Order # 17-71620

OD	Rows	Center Type	12+	6+	1+
3"	36	Lead	\$5.01	\$5.23	\$5.45
4"	36	Lead	\$6.21	\$6.48	\$6.75
5"	54	Lead	\$10.03	\$10.46	\$10.90
6"	54	Lead	\$9.66	\$10.08	\$10.50

#### E. HIGH-QUALITY CHAMOIS BUFF

Produces a high-mirror finish on precious metals. Also very effective for final mirror finish of platinum when using platinum rouge. Leather center.

Order # 17-13830

OD	Rows	Center Type	12+	6+	1+
3"	12	Leather	\$3.63	\$3.63	\$3.63
4"	18	Leather	\$15.23	\$15.89	\$16.55
5"	18	Leather	\$23.87	\$24.91	\$25.95



A



B



C



D



E



**A. AND B. WHITE COTTON FLAP BRUSHES**

This wheel has cotton flaps inside with crossed and opposite orientation of the cotton "weft and wrap" more or less at 45 degrees of inclination. These particular properties allow it to polish some metals as cotton discs do, but it also profiles the wheel continuing the polishing operation for a lot of pieces without losing the required and previously given form.

**GRAY WOOL FLAP BRUSHES**

"Sister" of the white cotton flap brushes features the same kind of construction, but with flaps of natural, selected, army wool texture. Particularly suited for polishing metals that need a lot of heating to shine like bronze, copper, silver, and brass (with compound). It maintains the capacity to profile like white cotton flap brushes without losing its form.

Item	Order #	OD	ID	Thickness	12+	6+	1+
A	10-7080	4 3/8"	1/4"	1 3/16"	\$30.96	\$32.30	\$33.65
B	10-7090	4 3/8"	1/4"	1 3/16"	\$29.90	\$31.20	\$32.50



**MICROFIBRA BUFFS**

Comprised of an innovative paper fiber material that is designed to not obstruct polishing motor filters, produce dust, or heat objects, these are ideal for use on all surfaces. These buffs have a more favorable yield compared to cotton discs and do not leave residual hairs behind. Use with suitable paste for finishing on stones and enamels. It works well on motors with turns from 2,800 (RPM) upward. It is normally dispatched through the recovery of the metals.

Order # 17-11100

OD	Thickness	Rows	Ply	Center	12+	6+	1+
7/8"	7/8"	0	10	Mounted	\$2.93	\$3.11	\$3.45
6"	5/8"	2	35	Plastic	\$11.50	\$12.00	\$12.50
6"	1 3/16"	2	52	Plastic	\$14.67	\$15.31	\$15.95
4 3/4"	5/8"	2	36	Plastic	\$9.20	\$9.60	\$10.00
4"	7/16"	2	26	Plastic	\$7.14	\$7.56	\$8.40



**COAGULATED CLOTH BUFFS**

Woven of a pure cotton impregnated with caucciú (a natural gum substance), these coagulated cloth buffs can be used to mirror polishing without creating superficial halos. Suitable for use on difficult surfaces, the buffs produce a minimal amount of dust, but after being impregnated with paste, this ceases to occur. Normally dispatched through the recovery of metals, the buffs tend to heat the object being polished.

Order # 17-11110

OD	Thickness	Rows	Ply	Center	12+	6+	1+
7/8"	7/8"	0	10	Mounted	\$3.27	\$3.47	\$3.85
4"	7/8"	1	20	Shellac	\$9.38	\$9.79	\$10.20
6"	5/8"	2	32	Shellac	\$20.84	\$21.74	\$22.65

**WHITE CLOTH BUFFS**

Suitable for all types of metals. Ideal for final polishing and brilliant finish. To be used with semi-dry red paste.

Order #	OD	Thickness	Rows	Ply	Center	12+	6+	1+
17-7106	4"	7/16"	1	65	Plastic	\$9.69	\$10.26	\$11.40



**CAMBRIQUE CLOTH BUFFS**

Very soft cloth and very compact. Suitable for high level finishing and polishing.

Order #	OD	Thickness	Rows	Ply	Center	12+	6+	1+
17-7107	4 3/4"	5/8"	1	96	Plastic	\$22.91	\$23.90	\$24.90



**MINIATURE POLISHING BUFF**

Silicone-coated cotton fabric (soft). Works best at 10,000 rpm.

Order #	OD	Thickness	Rows	Ply	Center	12+	6+	1+
17-1120	22"	7/8"	1	8	Metal	\$22.86	\$23.86	\$24.85



**SILICONE-COATED NETTLE CLOTH BUFF**

This siliconized cotton buff is very good for stainless steel and platinum. To be used at speed of 1,400 rpm, it is recommended that only one compound is used per buff

Order #	OD	Thickness	Rows	Ply	Center	12+	6+	1+
17-7302	100	5/8"	1	22	Plastic	\$10.67	\$11.14	\$11.60
17-7304	100	5/8"	1	20	Plastic	\$8.71	\$9.23	\$10.25



**SOFT SILICONE-COATED BUFF**

Soft, silicone-coated cotton fabric produces nearly no dust during the polishing process. Requires less pressure and has extremely long lifetime. This 20-layer siliconized buff is very good for precious metals at a low speed of 1,400 rpm. It is recommended that only one compound is used per buff.

Order #	OD	Thickness	Rows	Ply	Center	12+	6+	1+
17-7301	125	5/8"	1	24	Felt	\$17.09	\$18.09	\$20.10
17-7303	125	5/8"	1	24	Felt	\$14.75	\$15.62	\$17.35





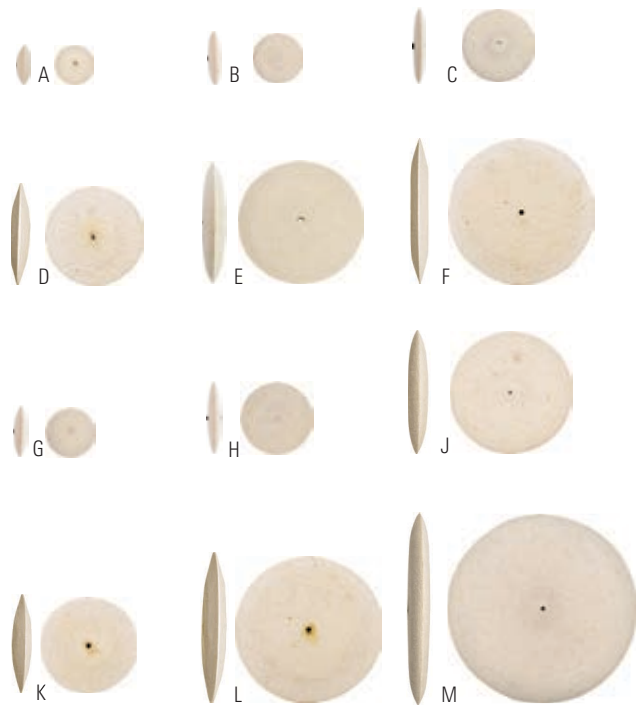

**KNIFE-EDGE SOLID FELT BUFFS**

Unmounted, knife-edge, hard, solid felt with tapered edges for polishing crevices. Contain pinholes for tapered or screw mandrels.

Order # 17-48390

Item	Description	OD	Per Unit	12+	6+	1+
A	Hard	5/8"	10	\$6.90	\$7.20	\$7.50
B	Hard	1"		\$1.10	\$1.15	\$1.20
C	Hard	1 1/2"		\$1.33	\$1.39	\$1.45
D	Hard	2"		\$2.12	\$2.21	\$2.30
E	Hard	2 1/2"		\$3.36	\$3.50	\$3.65
F	Hard	3"		\$3.45	\$3.60	\$3.75
G	Rock-Hard	1"		\$1.47	\$1.54	\$1.60
H	Rock-Hard	1 1/2"		\$1.75	\$1.82	\$1.90
J	Rock-Hard	2"		\$2.58	\$2.69	\$2.80
K	Rock-Hard	2 1/2"		\$4.09	\$4.27	\$4.45
L	Rock-Hard	3"		\$4.46	\$4.66	\$4.85
M	Rock-Hard	4"		\$7.82	\$8.16	\$8.50

**SQUARE-EDGE SOLID FELT WHEELS**

These high-grade wheels are excellent for all-purpose polishing and buffing. All have pinhole centers. Made in the USA.

Order # 17-44990



Item	Grade	OD	Thickness	12+	6+	1+
A	Soft	3"	1/2"	\$7.31	\$7.63	\$7.95
	Soft	4"	1/2"	\$9.38	\$9.79	\$10.20
	Soft	5"	1/2"	\$14.72	\$15.36	\$16.00
	Soft	6"	1/2"	\$17.71	\$18.48	\$19.25
B	Medium	2 1/2"	1/2"	\$4.51	\$4.77	\$5.30
	Medium	3"	1/2"	\$8.14	\$8.50	\$8.85
	Medium	4"	1/2"	\$11.41	\$11.90	\$12.40
	Medium	5"	1/2"	\$17.57	\$18.34	\$19.10
C	Hard	3"	1/2"	\$9.66	\$10.08	\$10.50
	Hard	4"	1/2"	\$11.87	\$12.38	\$12.90
	Hard	5"	1/2"	\$17.57	\$18.34	\$19.10
	Hard	6"	1/2"	\$25.39	\$26.50	\$27.60
D	Hard	6"	1"	\$44.85	\$46.80	\$48.75
	Hard	6"	3/8"	—	—	\$32.20
	Rock Hard	3"	1/2"	\$12.93	\$13.49	\$14.05
	Rock Hard	4"	1/2"	\$16.24	\$16.94	\$17.65
	Rock Hard	5"	1/2"	\$20.84	\$21.74	\$22.65
	Rock Hard	6"	1/2"	\$23.67	\$25.07	\$27.85



**MINIATURE MUSLIN BUFFS**

Use with mandrels 43-1280 or 43-1282.

Order # 17-61500

Item	OD	Rows	Ply	Color	12+	6+	1+
A	7/8"	1"	16	Yellow	\$0.79	\$0.86	\$0.95
B	1"	2"	16	Yellow	\$0.83	\$0.90	\$1.00
C	1 1/4"	2"	16	Yellow	\$1.10	\$1.15	\$1.20
D	7/8"	1"	16	White	\$5.60	\$6.08	\$6.75
E	1"	1"	16	White	\$5.82	\$6.17	\$6.85
F	1"	2"	16	White	\$0.66	\$0.72	\$0.80
G	1 1/4"	3"	16	White	\$0.72	\$0.77	\$0.85

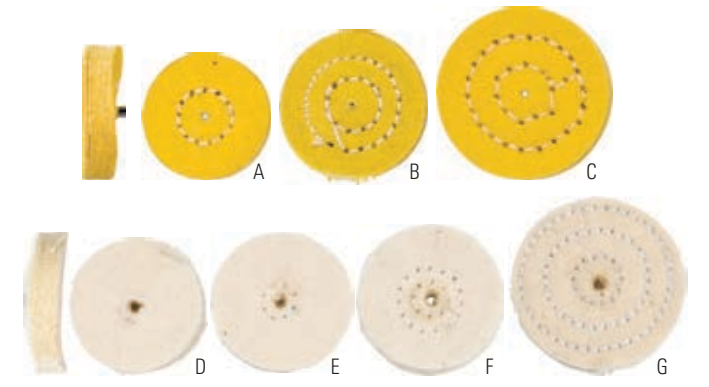

**MINIATURE, SOLID FELT WHEELS**

These high-quality, unmounted, felt wheels are excellent for all general polishing applications. Wheels are 1/8" thick (3.18 mm) and are unmounted.

Order # 17-35190

Item	Description	OD	Per Unit	12+	6+	1+
H	Soft	1/2"	10	\$1.79	\$1.87	\$1.95
	Soft	1/2"	100	\$13.94	\$14.54	\$15.15
J	Soft	5/8"	100	\$1.79	\$1.87	\$1.95
	Soft	5/8"	10	\$14.03	\$14.64	\$15.25
K	Soft	3/4"	10	\$1.79	\$1.87	\$1.95
	Soft	3/4"	100	\$14.21	\$14.83	\$15.45
L	Extra Soft	3/4"	10	\$11.87	\$12.38	\$12.90
	Soft	1"	100	\$20.56	\$21.46	\$22.35
M	Hard	1/2"	10	\$2.48	\$2.59	\$2.70
	Hard	1/2"	100	\$2.16	\$2.26	\$2.35
N	Hard	1/2"	100	\$15.23	\$15.89	\$16.55
	Hard	5/8"	10	\$2.07	\$2.16	\$2.25
P	Hard	5/8"	100	\$15.50	\$16.18	\$16.85
	Hard	3/4"	100	\$3.13	\$3.26	\$3.40
Q	Hard	3/4"	10	\$3.13	\$3.26	\$3.40
	Hard	1"	100	\$2.48	\$2.59	\$2.70
R	Hard	1"	10	\$17.07	\$17.81	\$18.55
	Soft	1 1/4"	Each	\$1.15	\$1.20	\$1.25

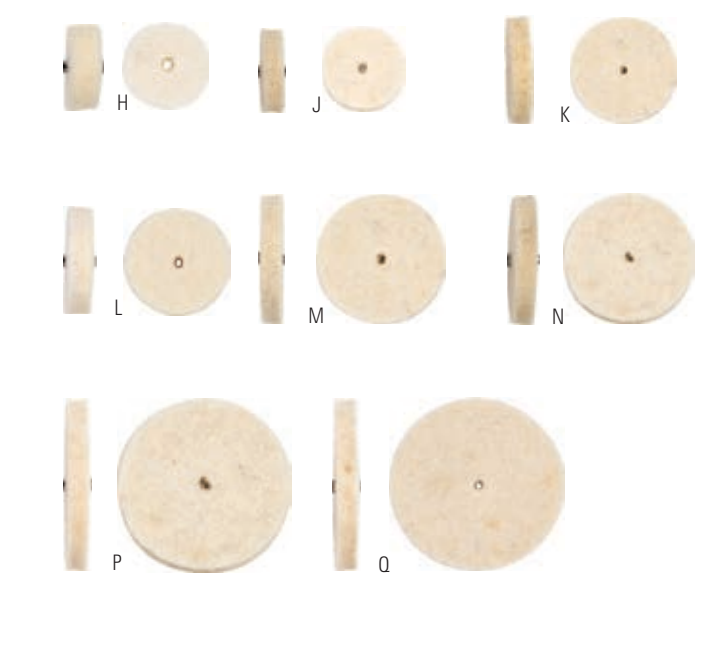

**MOUNTED MIDGET BUFFS**

3/32" shanks. One-inch diameter.

Order # 17-11050

Item	Description	Shape	Per Unit	12+	6+	1+
R	Felt	Square-Edge	12	\$11.87	\$12.38	\$12.90
S	Chamois	Square-Edge	12	\$20.84	\$21.74	\$22.65
T	Muslin	Square-Edge		\$7.08	\$7.39	\$7.70
U	String	Round		\$1.57	\$1.67	\$1.85
V	String	Round		\$1.70	\$1.78	\$1.85



**MOUNTED MIDGET FELT BUFFS**

3/32" shanks.

Order # 17-12010

Item	Shape	Per Pack	12+	6+	1+
W	Round	12	\$11.87	\$12.38	\$12.90
X	Bud	12	\$12.60	\$13.15	\$13.70
Y	Point	12	\$12.60	\$13.15	\$13.70
Z	Square	12	\$9.06	\$9.46	\$9.85
AA	Cylinder	12	\$8.56	\$8.93	\$9.30





**SOLID FELT RING BUFFS**

Unmounted. Use directly on tapered spindles. Regular length.

Order # 17-33200

Item	OD	Length	12+	6+	1+
A	9/16"	3"	\$2.12	\$2.30	\$2.55
B	5/8"	4"	\$2.12	\$2.30	\$2.55



Infant Buff

**TAPERED FELT-INSIDE RING BUFF**

Ring buffs are mounted on wooden mandrels. Attaches to a spindle motor.

Order # 17-31500

Item	OD	Length	Taper	12+	6+	1+
C	9/16"	3"	5/16"	\$2.61	\$2.84	\$3.15
D	7/8"	4"	5/16"	\$2.72	\$2.88	\$3.20
E	1"	5"	11/16"	\$3.78	\$4.10	\$4.55



**FELT BUFF AND KNIFE-EDGE WHEEL**

Felt combination buff is mounted on wood mandrel. Has knife-edge wheel.

Order # 17-34130

Item	ID	Length	Taper	Wheel Diameter	12+	6+	1+
F	3/4"	3"	7/16"	2"	\$5.29	\$5.52	\$5.75
G	7/8"	4"	5/8"	2"	\$5.61	\$5.86	\$6.10



**FELT COMBINATION BUFFS**

Consists of a wheel buff and an inside-ring buff mounted on a wooden mandrel. Allows polishing of the inside and outside of rings without changing buffs.

Order # 17-34000

Item	ID	Length	Taper	Wheel Diameter	Weel Thickness	12+	6+	1+
H	3/4"	3"	9/16"	2"	1/2"	\$5.36	\$6.03	\$6.70
J	7/8"	4"	5/8"	2"	9/16"	\$5.36	\$6.03	\$6.70
K	5/8"	3"	13/16"	2 1/2"	1/2"	\$5.36	\$6.03	\$6.70



**TAPERED FELT-INSIDE RING BUFF**

Ring buffs are mounted on wooden mandrels. Attaches to a spindle motor.

Order #	OD	Length	Taper	12+	6+	1+
17-31500	3/4"	3"	5/16"	\$2.61	\$2.84	\$3.15



**RING BUFF**

Four-inch, hard-inside ring buff.

Order #	OD	Length	Taper	12+	6+	1+
11-3177	7/8"	4"	5/8"	\$4.38	\$4.64	\$5.15



**FELT STICKS**

Felt sticks can be used with polishing compounds and diamond polishing past. 1/4" square x four inches long with 45 degree bevel ends. Made with 100% wool.

Order # 17-3317

Item	Grade	Thickness	12+	6+	1+
A	Soft	1/4"	\$1.43	\$1.49	\$1.55
B	Medium	1/4"	\$1.20	\$1.25	\$1.30
C	Hard	1/4"	\$1.43	\$1.49	\$1.55



**FELT BRACELET BUFF**

Made of high-grade, pure, solid felt, these medium density buffs are mounted on a hardwood core. Shaped to fit the larger diameters of bangles and bracelets. Use on tapered spindle polishers.

Order #	OD	Length	12+	6+	1+
17-3315	2"	2"	\$8.14	\$8.50	\$8.85

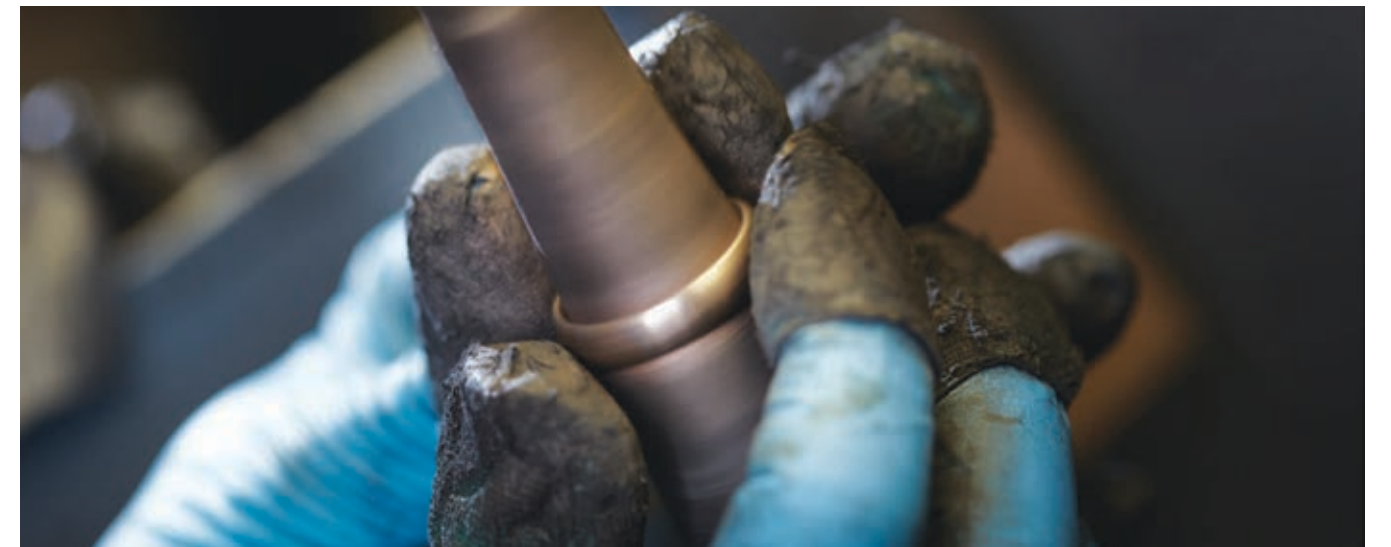





**BERGEON SATIN FINISH WHEEL**

Bergeon ultra-fine wheel is used to apply a satin finish on jewelry.

Order #	Grade	OD	Thickness	1+
17-8743	Fine	4"	3/4"	\$35.10

**ALUMINUM-OXIDE FLAP WHEELS**

The most popular item in the jewelry world is used for every kind of satin finishing pattern from the roughest (Grit A/Coarse) to the finest (Grit/Ultra-Fine).

Order # 10-70700



Item	Grade	OD	Thickness	ID	12+	6+	1+
A	Coarse	4"	1"	1/4"	\$9.73	\$10.31	\$11.45
B	Medium	4"	1"	1/4"	\$9.73	\$10.31	\$11.45
C	Fine	4"	1"	1/4"	\$9.73	\$10.31	\$11.45
D	Extra Fine	4"	1"	1/4"	\$9.73	\$10.31	\$11.45



**SILICON-CARBIDE FLAP WHEELS**

The most popular item in the jewelry world is used for every kind of satin finishing pattern from the roughest (Grit A/Coarse) to the finest (Grit/Ultra-Fine).

Order # 10-70740

Item	Grade	OD	Thickness	ID	12+	6+	1+
E	Fine	4"	1"	1/4"	\$9.73	\$10.31	\$11.45
F	Super-Fine	4"	1"	1/4"	\$9.73	\$10.31	\$11.45
G	Ultra-Fine	4"	1"	1/4"	\$9.73	\$10.31	\$11.45



**ALUMINUM-OXIDE FLAP WHEELS**

Versatile wheels can be used for light deburring and polishing on gold, silver, and other non-ferrous metals. Excellent for producing a satin finish. Four-inch (101.6 mm) diameter, 3/4" (19.1 mm) thick, and 1/4" (6.4 mm) arbor hole.

Order # 17-87320

Item	Grade	12+	6+	1+
H	Coarse	\$13.86	\$14.67	\$16.30
J	Medium	\$13.86	\$14.67	\$16.30
K	Fine	\$15.00	\$15.65	\$16.30
L	Extra-Fine	\$15.13	\$16.02	\$17.80



**SATIN-FINISH WHEELS**

Use to obtain matte finishes on metal and plastic. Abrasive granules are impregnated into the nylon fibers. Four-inch (101.6 mm) diameter, 3/4" (19.1 mm) thick, and 1/4" (6.4 mm) arbor hole.

Order # 17-87000

Item	Grade	12+	6+	1+
M	Coarse	\$5.52	\$5.76	\$6.00
N	Medium	\$5.52	\$5.76	\$6.00
P	Fine	\$4.05	\$4.22	\$4.40

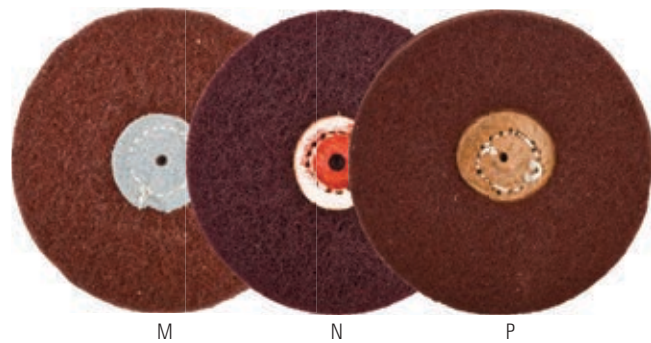

**MOUNTED MINIATURE SATIN-FINISH BUFFS**

Made of synthetic fiber, these produce a satin finish on gold, silver, and other metals. Mounted on 3/32" mandrel.

Order # 17-90010

Item	Grade	OD	Thickness	12+	6+	1+
A	Fine	3/4"	1/4"	\$1.29	\$1.34	\$1.40
B	Medium	3/4"	1/4"	\$1.38	\$1.44	\$1.50
C	Fine	1"	1/4"	\$1.47	\$1.54	\$1.60
D	Medium	1"	1/4"	\$1.56	\$1.63	\$1.70

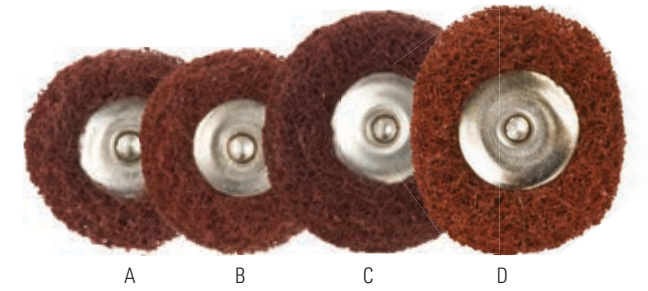

**WOODEN POLISHING SPINDLE**

Polish your rings and bracelets/chains with this select, hardwood tool. Ingenious and indispensable for any workbench.

Order #	Description	12+	6+	1+
43-0607	Dual Purpose Wooden Polishing Spindle	\$6.12	\$6.48	\$7.20



**WOODEN POLISHING SPINDLE**

Innovative tool is used to polish chains, bracelets, watchbands, and pendants. Helps the jeweler do the perfect job quickly and easily. Just place and hold the jewelry piece in the polish cradle while rotating the tool against the buff wheel of the polishing machine. Made of solid wood. Will not conduct heat from the rotating buff wheel.

Order #	Description	12+	6+	1+
43-0606	Wooden Polishing Spindle	\$11.82	\$12.34	\$12.85



**BUFF CLEANING RAKE**

Buff rakes are necessary to clean off compound buildup on buffs. The rakes should be used often to remove buildup from compounds, remove metal particles that cause draglines, and open up the buff to receive fresh polish compounds.

Order #	Description	Length	12+	6+	1+
43-0610	Buff Rake	15"	\$15.43	\$16.34	\$18.15



**LEATHER STRIPS**

Genuine cowhide leather strap is used for holding jewelry and rings while polishing, buffing, or grinding. Protects fingers from heat.

Order #	Description	Length	12+	6+	1+
17-0905	Leather Strips	3"	\$21.55	\$22.82	\$25.35





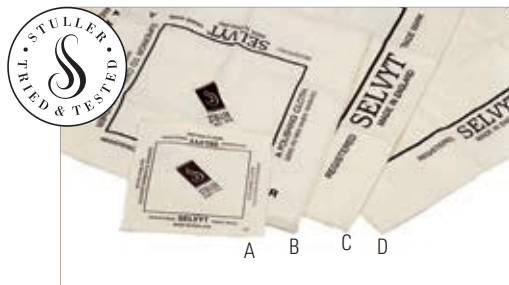

**SELVYT® CLOTH**

Lint-free jewelry cleaning cloths. SR quality.

Order # 17-08000

Item	Style	W×L	12+	6+	1+
A	0	5"×5"	\$1.52	\$1.58	\$1.65
B	A	10"×10"	\$5.57	\$5.81	\$6.05
C	B	14"×14"	\$6.49	\$6.77	\$7.05
D	C	17"×14"	\$9.34	\$9.74	\$10.15



**FABULUSTRE® POLISHING CLOTH**

Double cloth with one side impregnated with jeweler's rouge and the other side for final polish.

Item	Order #	Description	W×L	12+	6+	1+
E	17-0760	Polishing Cloth	9"×11"	\$4.69	\$4.90	\$5.10



**MAGIC CLOTH**

Space-age cleaning cloth will revolutionize the cleaning of loose stones. The Magic Cloth, with its specially treated microfiber, is simply the best and most effective way to clean your loose stones. No lint residue. Removes dust, dirt, and fingerprints and won't scratch.

Order # 17-07620

Item	Color	W×L	12+	6+	1+
F	Maroon	7"×6"	\$2.07	\$2.16	\$2.25
G	Gray	7"×6"	\$2.07	\$2.16	\$2.25
H	Blue	7"×6"	\$2.07	\$2.16	\$2.25
J	Green	7"×6"	\$2.07	\$2.16	\$2.25

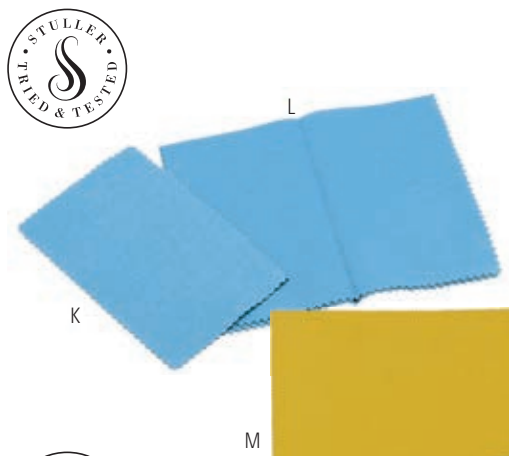

**BRILLIANT POLISHING CLOTH**

Newly developed chemical treatment polishers help prevent tarnish from reappearing. Polishes brass, chrome, copper, silver, and gold without the rouge mess on your hands.

Order # 17-07700

Item	Color	W×L	12+	6+	1+
K	Blue	4"×6"	\$2.16	\$2.26	\$2.35
L	Blue	12"×8"	\$3.08	\$3.22	\$3.35
M	Yellow	12"×8"	\$3.54	\$3.70	\$3.85



**GEMBRIGHT LINTLESS CLOTH**

Microfiber for maximum softness for cleaning stones or metal surfaces. Untreated and an excellent value. Also a great resale item.

Item	Order #	Description	W×L	12+	6+	1+
N	17-0820	Lintless Cloth	9"×10"	\$3.77	\$3.94	\$4.10

**REVOLUTIONARY HIGH-PERFORMANCE POLISHING CLOTH**

The high-performance cloth features technology that provides ultra cleaning power because of its knitted interwoven design.

- Scratch-, smear-, streak-, and lint-free
- Easy removal of smudges, grease, dust, and polish residue
- Can be used wet or dry
- Machine washable up to 25 or 30 times
- No polishing compounds are in the cloth.

Order # 17-10000

Item	Description	W×L	12+	6+	1+
A	Polishing Cloth	12 ¾"×14"	\$4.05	\$4.22	\$4.40
B	Polishing Cloth	6"×7"	\$2.21	\$2.34	\$2.60

**JEWELRY POLISHING CLOTH**

This 6" x 8" two-ply cloth is made from 100% soft flannel.

The white interior cloth is thoroughly treated with the finest polishing agents that remove and inhibit tarnish, leaving gold, silver and platinum shining like new.

Item	Order #	Description	1+
C	17-0748	Polishing Cloth	\$1.05

**HELI FOUR-IN-ONE JEWELRY POLISHING CLOTH**

This jewelry cloth offers the opportunity to clean various kinds of jewelry with one cloth only. It cleans, cares, and brings back the brilliance. Turquoise for cleaning pearls and stones, Light Gray for finish polishing, Purple for cleaning gold, Dark Gray for cleaning silver. Proven quality Made in Germany.

Item	Order #	Description	12+	6+	1+
D	17-0823	Jewelry Polishing Cloth	\$9.06	\$9.46	\$9.85

**TUXEDO-STYLE COTTON GLOVES**

Presentation-style gloves that work well for keeping a high polish on all jewelry.



Item	Order #	Description	12+	6+	1+
E	17-0751	Cotton Gloves (1 pair)	\$2.42	\$2.76	\$3.45

**JEWELRY HANDLING GLOVES**

Set up fingerprint-free displays. These are used to protect jewelry, silverware, and other items from fingerprints, spotting and tarnishing.

Used extensively in jewelry stores and manufacturing facilities. Sold in packs of 12.

Order # 17-07500



Item	Description	12+	6+	1+
F	Heavyweight Cotton Gloves (12 pair) Small	\$6.03	\$6.29	\$6.55
	Lightweight Cotton Gloves (12 pair) Medium	\$8.33	\$8.69	\$9.05
	Heavyweight Cotton Gloves (12 pair) Large	\$7.54	\$7.87	\$8.20

**POLISHING GLOVES**

This left- or right-handed glove is specially treated to polish silver, gold, and plated items. Works great to remove tarnish from silver.



Item	Order #	Description	12+	6+	1+
G	17-0749	Polishing Gloves	\$5.23	\$5.67	\$6.30







**LEATHER FINGER COTS**

Soft leather guard necessary for use in protecting fingers from compounds, heat, and abrasion during grinding and finishing.

Order # 47-52660

10

Description	12+	6+	1+
Small/Medium (Women's)	\$13.60	\$15.30	\$17.00
Medium/Large (Men's)	\$13.60	\$15.30	\$17.00
Thumb Size (Mens)	\$13.60	\$15.30	\$17.00



**FINGER COTS**

Comfortable cotton and elastic finger cots help protect your fingers as well as your skin while adding support and security when handling jewelry.

Order # 47-5269

20

Order #	Description	12+	6+	1+
47-5269	Finger Cots	\$6.84	\$7.25	\$8.05



**LEATHER FINGER GUARDS**

Elastic-backed, leather finger guards are a must for polishing or grinding. Protects fingers from heat, compounds, and abrasives. Split Leather: Has a rough texture that resists cuts, abrasions, and wear longer than grain leather.

Order # 47-52600

Item	Description	Material	12+	6+	1+
A	Open-End Finger Guard	Split Leather	\$0.83	\$0.86	\$0.90
B	Open-End Thumb Guard	Split Leather	\$0.87	\$0.91	\$0.95
C	Over-End Finger Guard	Split Leather	\$1.01	\$1.06	\$1.10
D	Over-End Thumb Guard	Split Leather	\$1.01	\$1.06	\$1.10
E	Over-End Finger Guard	Grain Leather	\$1.01	\$1.06	\$1.10
F	Closed-End Finger Guard	Grain Leather	\$1.33	\$1.39	\$1.45

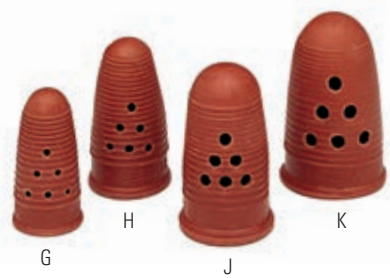

**RUBBER FINGER PADS**

Superior quality rubber finger pads have sure grip and are ventilated for comfort.

Order # 69-11010

12

Item	Description	12+	6+	1+
G	#11 Small	\$5.98	\$6.24	\$6.50
H	#12 Medium	\$5.80	\$6.05	\$6.30
J	#13 Large	\$5.98	\$6.24	\$6.50
K	#14 Extra-Large	\$5.98	\$6.24	\$6.50

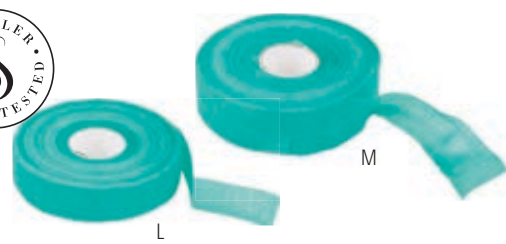

**FINGER PRO TAPE**

Finger Pro is the ultimate finger protection from cuts, burns, and abrasions. It is thin and tough and allows the user to handle small articles much better than conventional cots or gloves. This unique tape sticks only to itself and not to your skin.

Order # 23-25000

Item	Description	WxL	12+	6+	1+
L	Finger Tape	¾"×90"	\$1.79	\$1.87	\$1.95
M	Finger Tape	1"×90"	\$2.02	\$2.11	\$2.20

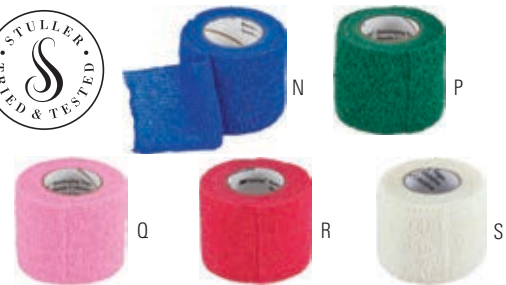

**VETRAP® TAPE**

The ultimate in finger protection from cuts, burns, and abrasions, it allows user to handle small articles. Unique tape that only sticks to itself.

Order # 23-24000

Item	Description	WxL	12+	6+	1+
N	Blue	2"×15"	\$2.12	\$2.21	\$2.30
P	Hunter Green	2"×15"	\$2.12	\$2.21	\$2.30
Q	Hot Pink	2"×15"	\$2.12	\$2.21	\$2.30
R	Red	2"×15"	\$2.12	\$2.21	\$2.30
S	White	2"×15"	\$2.12	\$2.21	\$2.30

**RAYTECH MAGNETIC FINISHER**

This small capacity finisher has programmable functions and can hold 8 to 12 small rings or findings.

Unit includes bowl, stainless steel pins, and tumbling soap.

Unit features a green start button, red stop button, timer and speed control with forward and reverse function.

Item	Order #	Description	Ring Capacity	Pin Capacity	1+
A	47-5007	Raytech CFM 410	8-12	100	\$701.17

Order # 47-50080 ACCESSORIES

Item	Description	OD	1+
B	Dry Bowl	4"	\$168.50
C	Wet Bowl	4"	\$165.10
D	Parts Holder		\$58.55



17 lbs

**RAYTECH MAGNETIC FINISHER**

This finisher holds 30 to 50 small rings or findings. The unit, also programmable, includes bowl, stainless steel pins, and tumbling soap. It features a green start button, red stop button, timer, and speed control with forward and reverse function.

Item	Order #	Description	Ring Capacity	Pin Capacity	1+
E	47-5021	Raytech CFM 610	30-50	200	\$1,325.39

Order # 47-50220 ACCESSORIES

Item	Description	1+
F	Dry Bowl	\$191.60
G	Wet Bowl	\$193.40
H	Parts Holder	\$72.05

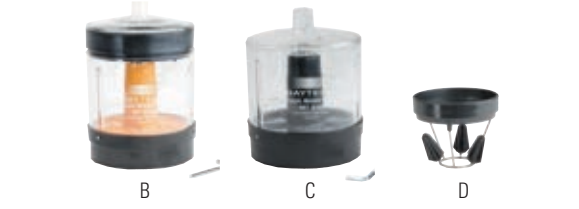

25 lbs

Only with Raytech's Flex-System can you utilize three types of functions. Raytech's models 410 and 610 have compatible bowls.

**Wet Burnishing Pins**

- High luster burnishing
- Edge smooth/light radiusing

**Abrasive (wet): CBW bowls required**

- Surface refinement
- Edge radiusing
- Uniform surface quality
- Cut down

**Dry Processing: CBD bowls required**

- Decorative finish
- Bright, refined and uniform buff-like, high luster quality

Change and rinse as frequently as required to keep the process clean.



**RAYTECH FINISHING MEDIA**

**J. Dri-Buff Media:** A corn-based media that will provide a mirror finish and can be used in our CMF dry bowls with cycles of approximately 30-40 minutes. As with the Dri-Shine VII, alternate the media between cycles to prevent overheating of the media. Note when using Dri-Buff in the CMF-410 or CMF-610 finishers, run the machine at half speed.

**K. Dri-Shine VII Media:** A corn-based media that will provide a mirror finish and can be used in our CMF dry bowls with cycles of approximately 30-40 minutes. As with the Dri-Shine VII, alternate the media between cycles to prevent overheating of the media. Note when using Dri-Shine VII in the CMF-410 or CMF-610 finishers, run the machine at half speed.

**L. Dri-Shine VII Reactivator:** Reactivate every four to six cycles to keep the media active. Reactivator will work into the Dri-Shine VII in only a few minutes. Use ½ teaspoon of Reactivator in the CMF-410 dry bowl, and one teaspoon in the CMF-610 dry bowl.

Order # 47-50130

Item	Description	12+	6+	1+
J	4 lb Bucket Dri-Buff	\$26.68	\$28.94	\$32.15
K	5 lb Bucket Dri-Buff	\$37.87	\$40.10	\$44.55
L	1 lb Bucket Dri-Shine (recharger)	\$26.68	\$28.94	\$32.15





**MAGNETIC TUMBLER**

Help cut down on polishing time by using one of these tumblers. Best Built tumblers polish those intricate pieces where normal polishing doesn't work. Replacement bowls are available.

**Order # 47-50410**

Watts	Weight	Ring Capacity	Bowl Size	1+
15	12 lbs	1-6	3 1/2" x 2 3/4"	\$249.00
90	22 lbs	10-22	5 1/8" x 4 3/8"	\$695.00



**MAGNETIC PIN SEPARATOR**

Eliminates tedious separation of parts from stainless steel media. Insert the wand into your bowl, pull the trigger to activate, and stir. The stainless steel media will attach to the wand until you release the trigger.

Order #	Description	1+
<b>47-5058</b>	Magnetic Pin Separator	\$131.55



**REPLACEMENT BOWL FOR ARBE MAGNETIC TUMBLER**

Replacement bowl for Arbe Magnetic Tumbler (**47-4137**)

**Order # 47-4137**

Item	Description	12+	6+	1+
A	Magnetic Tumbler	—	—	\$279.00
B	Replacement Bowl	\$41.81	\$43.63	\$45.45



**STAINLESS STEEL PINS**

These stainless steel pins are approximately 5mm x 0.5mm. Use with our magnetic finishers and Stuller finishing soap **#54-4453**.

Item	Order #	Description	WxL	12+	6+	1+
A	<b>47-5055</b>	Steel Pins	5mm	\$13.76	\$15.72	\$19.65
B	<b>47-5056</b>	Rounded Shot 3mm	1/2" x 3"	\$35.94	\$38.97	\$43.30
C	<b>47-5056</b>	Rounded Shot 5mm	1/2" x 5"	\$35.94	\$38.97	\$43.30



**ARBE VARIABLE SPEED MAGNETIC TUMBLER**

These Super Finish magnetic tumblers have a small foot print but do big things. A heavy duty motor provides robust power while the faceted bowl maximizes rotational action. Exclusive magnetic head design also incorporates vertical pin action allowing the finisher to add high polish finish on many pieces including filigree work. The bowl holds 8 rings per batch using 60-70 grams of stainless steel pins designed to achieve a high shine finish even in hard to reach places, this finisher includes 65 grams of 0.5mm x 5mm stainless steel pin media.

- Unit Dimensions: 6.5" deep x 8" wide x 8" height
- Bowl Size: 4" diameter x 3.5" height
- Timer: 0-60 minute mechanical
- Capacity: 8 ring
- Speed: 0-3450 RPM variable

**Order # 47-4153**

Description	1+
Variable Speed Tumbler	\$349.99

**POLYCHEM MF610 BURNISHING COMPOUND**

This concentrated liquid is a mildly acidic finishing product for high-speed burnishing and tumbling and burnishing applications using magnetic needles. Contains special lubricating additives and produces a lustrous and polished finish to silver, gold, platinum, rhodium, and their alloys, as well as other precious metals. Mixing ratio: one part Polychem MF610 to 50 parts water.

Order #	Description	Weight	12+	6+	1+
<b>54-4453</b>	Polychem MF610	1 Gallon	\$26.08	\$29.34	\$32.60



Find added video content on [Stuller.com/VideoCenter](http://Stuller.com/VideoCenter).







**VIBRATORY TUMBLERS**

Use dry only-cannot be used with Flow-Through system.

- Capacity approximately 50 rings
- 3-quart capacity
- .10 cu. ft.
- Holds 3 lbs dry media
- Bowl size 10" x 4" high
- Ship weight 12 lbs.

Order #	Description	1+
47-5053	3qt Dry	\$249.00



**VIBRATORY TUMBLERS**

**Six Quart:** Can be used wet or dry.

- Capacity approximately 100 rings
- 6 quart capacity
- .20 cu. ft. holds 15 lbs. of plastic shot
- 6 lbs dry shot
- Ship weight 19 lbs
- Bowl size 11½" x 6" high

**Three Quart:** Can be used wet or dry.

- Capacity approximately 50 rings
- 3-quart capacity
- .10 cu. ft.
- Holds 8 lbs of plastic media
- 3 lbs dry shot
- Ship weight 12 lbs
- Bowl size 10" x 4" high

Order # 47-5054

Item	Description	1+
A	6qt Wet/Dry	\$479.00
B	3qt Wet/Dry	\$349.00



**RAYTECH VIBRATORY TUMBLERS**

A. The industrial model TV-10 has light-duty drive and suspension combined with a tough, cross-linked polyethylene 10-inch bowl. Has a noise reducing lid and a liquid drain. The machine is equipped for use with Raytech's FT-20 compound rinsing system. Do not run steel shot in this machine; doing so will void the warranty.

- Volume Capacity (Decimal Cu. Ft.) 0.10 (35 to 40 rings)
- Wet/Dry Operation
- Horsepower 1/15
- Drain For Recirculation Yes
- Adjustable Amplitude No
- Tilt Feature No
- Maximum Voltage Rating 115V
- Shipping Weight 12lbs
- Outside Diameter 10"

B. This machine is specifically designed for use where steel or stainless steel media processing is required although all medias can be used. It is designed with a heavy-duty drive and suspension system and has adjustable amplitude. The AV-25SS has all the features of our larger machines and is a popular size for small production lots. The 14-inch bowl has a discharge port for easier unloading and a capacity of .22 cubic feet. Steel or stainless steel media capacity is 40 pounds including parts. CE

- Stationary base with adjustable vibration amplitude
- Convenient unloading plug
- 7qt. flow-thru bowl 14"Diameter x 5¼" Depth
- Capacity 3 cups (100 rings)
- 110V

C. For fast, easy unloading, the best choice would be Raytech's Tumble-Dump models 40, 75 or 75DC. These models incorporate all the features of the Adjusta-Vibe models with one addition: Raytech's patented Tumble-Dump tilting plate. Discharge port on TD-75DC only. CE

- Capacity 6 cups (200 rings)
- 3 gal. flow-thru bowl 16" Diameter x 7½" Depth
- 110V

D. This unit incorporates a flow-through design for compound rinsing and comes with a 32-quart tank that allows up to eight hours of compound dispensing utilizing a needle valve control for metering. The integral zero to six-hour timer control panel allows a tumbler to be directly plugged into the base. Recommended for jewelry and precious metals. Use with tumbler models AV-40, AV-40SS, TD-40, AV-75, AV-75DC, TD-75, TD-75DC. CE

Order # 47-50320

Item	Description	1+
A	TV10	\$272.80
B	AV25SS	\$731.55
C	TD40	\$1,564.97
D	Flo Thru 75 System	\$599.00



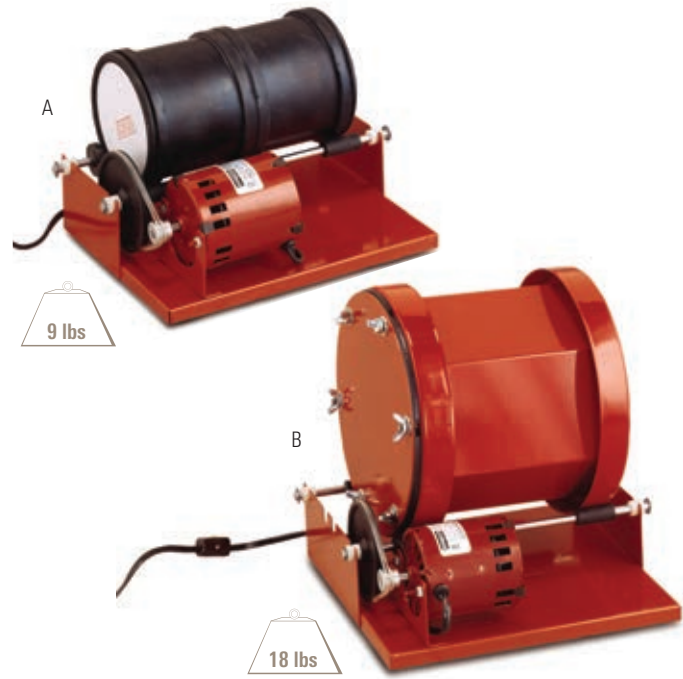

**BARREL TUMBLERS**

A. Versatile, two-barrel, six-pound (2.7kg) capacity tumbler uses two three-pound long-life molded rubber barrels. Ideal for small batches of jewelry. Continuous-duty, fan-cooled motor features overload protection.

B. Professional quality tumbler features a larger, more powerful, continuous-duty, fan-cooled motor with overload protection. Steel hexagon barrel with removable liner ensures long, efficient- and quiet operation. 15-pound capacity, with a five-year warranty on the barrel and liner.

Item	Order #	Description	1+
A	47-5160	Two Barrel Tumbler	\$169.50
B	47-5164	Heavy Duty Barrel Tumbler	\$263.85

**TUMBLING MEDIA**

Porcelain balls are utilized to achieve bright finishes without the use of steel media. Because of its shape, it imparts a single point of contact resulting in a very fine finish to almost any area it can reach. Porcelain balls will not leave impingement marks that steel media produces on some other softer metals and/or flat surfaces. Their lighter weight lessens the distortion potential for lighter work and wire forms. Very popular for delicate parts, fine edge blanking and precious metal burnishing. Use with Raytech's Compound D. Mixing the sizes is recommended for good vibratory action. Please note that a break-in period of four to six hours is required. Density: 125 lbs/cu ft.

Order # 47-5039

Description	Size	12+	6+	1+
1mm Porcelain Balls	5 lb	\$43.86	\$46.44	\$51.60
2mm Porcelain Balls	5 lb	\$43.86	\$46.44	\$51.60
3mm Porcelain Balls	5 lb	\$42.16	\$44.64	\$49.60
4mm Porcelain Balls	5 lb	\$41.86	\$44.33	\$49.25
6mm Porcelain Balls	5 lb	\$42.37	\$44.87	\$49.85

Order #	Description	Size	12+	6+	1+
47-5242	Jewelers Polishing Media	10 lb	\$67.90	\$70.85	\$73.80

**TUMBLING MEDIA**

Formulated for very fine surface conditioning, low RMS finishes are commonly achieved. Plastic medias are widely used in the precision metal industries. Also due to the fine surface finishes achieved, parts are prepared for pre-plate, pre-anodize, or decorative polishing. Brown, V-Cut, Cone (medium cut), Green (light cut), and White (very fine cut). Density: 55 lbs/cu ft.

Order # 47-5037

Description	1+
1/4" Brown Pyramids	\$55.35
1/4" White Pyramids	\$55.35

**JEWELER'S POLISHING MEDIA**

3mm Porcelain Triangle Polishing Media. 10-pound bag.

Order #	Description	12+	6+	1+
47-5243	Polishing Media	\$67.90	\$70.85	\$73.80



**TUMBLING MEDIA**

Ceramic is the heaviest media and is also the fastest finisher. Bonded of the highest quality materials available, selected aluminum oxide abrasives produce constant quality. This durable, long-lasting media is extremely versatile for deburring machined, cast, or fabricated parts. Density: 90 lbs/cu ft.

Order # 47-5052

Description	1+
5/16" x 3/4" Ceramic Angle Cut Cylinders 20lbs	\$73.75
3/8" x 7/8" Angle Cut Cylinders	\$80.95



**TUMBLING MEDIA**

Ceramic is the heaviest media and is also the fastest finisher. Bonded of the highest quality materials available, selected aluminum oxide abrasives produce constant quality. This durable, long-lasting media is extremely versatile for deburring machined, cast, or fabricated parts. Density: 90 lbs/cu ft.

Order #	Description	1+
47-5057	3/8" Polyhedrons	\$101.40



**TUMBLING MEDIA**

Formulated for very fine surface conditioning, low RMS finishes are commonly achieved. Plastic medias are widely used in the precision metal industries. Also due to the fine surface finishes achieved, parts are prepared for pre-plate, pre-anodize, or decorative polishing. Brown, V-Cut, Cone (medium cut), Green (light cut), and White (very fine cut). Density: 55 lbs/cu ft.

Order #	Description	1+
47-5061	5/16" XF Cones	\$117.80







**CERAMIC FINISHING MEDIA**

Ceramic media is recommended for heavy deburring or material removal on castings, machined ferrous metals, and stainless steel. Use with our #54-4453 burnishing compound. Cylinder Wedge: General purpose cylinder wedge for aggressive deburring. Produces a dull matte finish in 10 to 20 minutes. Cone: Angel-cut triangle good on small parts. Produces a dull finish in 15 to 30 minutes.

Order # 47-52300

Item	Grade	WxL	Shape	1+
A	Coarse	3/4"x5/8"	Cylinder Wedge	\$41.05
B	Medium	3/16"x3/8"	Cone	\$39.55

**PLASTIC FINISHING MEDIA**

Plastic media is recommended for general purpose deburring and material removal on non-ferrous castings, gold, silver, brass, and copper. Plastic media comes in either a polyester or urea-bonded shape and produces a dull matte to slight luster on parts. Use with our #54-4464 burnishing compound.

**Cylinder Wedge:** Used for aggressive deburring. Produces a dull matte luster in 15 to 20 minutes.

**Cone:** Produces a smooth finish and a slight luster on parts in 30 to 60 minutes. Good for small parts.

**Pyramid:** Produces a smooth finish and a good luster in 60 to 180 minutes. Good for detail work.

Order # 47-52350

Item	Grade	Size	Shape	1+
C	Coarse	5/8"	Cylinder Wedge	\$40.80
D	Medium	3/8"	Cone	\$50.75
E	Fine	1/4"	Pyramid	\$65.10

RAYTECH



**MEDIA SCREENS**

Screens for manually separating parts from media are 1 1/2 inches in diameter x 2 1/2 inches deep (approximately .25 cubic feet). They are also useful for separating undersize media from useable media. Made of high-impact polymer with integral screen, one-piece molding eliminates problems with parts and media sticking at the joints of two-piece screens. Screens nest for storage.

Order # 47-5038

Description	1+
1/4" Screen	\$27.45
3/8" Screen	\$27.45
1/2" Screen	\$27.45
3/4" Screen	\$27.45
1" Screen	\$27.45
Screen Container	\$30.30
Set of 5 Screens	\$106.05
Set of 5 Screens with Container	\$138.05

**MIXED STEEL SHOT**

A fast form of tumbling used to burnish metal to a mirror bright finish. Uniform in size and shape, non-abrasive, and carefully tempered to ensure long life. Carbon steel requires special storage to prevent rust and corrosion. Stainless steel shot is rust- and corrosion resistant, requiring no special storage and making it ideal for use in wet, flow-through systems. The mix consists of 3/16" (4.8mm) balls, 3/16" (4.8mm) ballcones, 1/8" x 3/8" (3.2mm x 9.5mm) pins, and 1/8" (3.2mm) diagonals for maximum coverage on a wide variety of pieces.

Order # 47-52400

Item	Description	Weight	12+	6+	1+
A	Carbon Steel	10 lbs	\$104.42	\$108.96	\$113.50
B	Stainless Steel	10 lbs	\$191.77	\$200.11	\$208.45

**LIQUID SHOT CONDITIONER**

A non-abrasive, deburring, and cleaning compound for use with steel shot. Provides excellent rust and corrosion protection. Fully biodegradable. Concentrated, mix one to two ounces per gallon.

Item	Order #	Description	Weight	12+	6+	1+
C	54-4463	Liquid Shot Conditioner	1 Gallon	\$32.29	\$33.70	\$35.10

**TREATED DRY POLISHING MEDIA**

This media can be used on all metals to produce an excellent mirror finish.

Order # 47-52150

Item	Description	1+
D	Corn Cob	\$44.30
E	Walnut Shell	\$47.45

**TREATED RED DRY MEDIA**

This red polishing material contains soft iron oxide and is used for finishing yellow metals such as gold, brass, copper, or bronze.

Order # 47-52190

Item	Description	1+
F	Corn Cob Red Media	\$39.70

**POLISH PASTE**

Paste compounds are used to treat organic materials such as wood shapes, sawdust, corn cob, and walnut shell to create treated compound media to enhance the finishing process. Comes in one-quart concentrate.

Order # 47-52220

Item	Description	Used For	12+	6+	1+
G	Aluminum Paste	General Purpose	\$34.50	\$36.00	\$37.50
H	Green Paste	White Metals	\$33.35	\$34.80	\$36.25

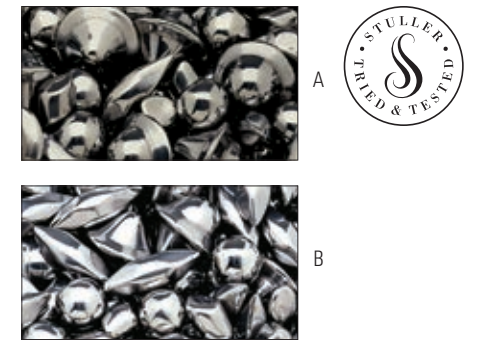



# SAFETY SUPPLIES



## 3M® RESPIRATORS

Respirator selection should first be based on the contaminant (e.g. lead, metal, fume, solvents) and the concentration of the contaminant in the workplace. Particulates (requiring filters) in the jewelry industry can include: metal fumes, silica, dust, and some acids (phosphoric and sulfuric). Gases and vapors involved in this trade may include solvents, such as toluene and xylene. Half-mask respirators protect a worker up to 10 times the PEL (OSHA's Permissible Exposure Limit), and full-face respirators up to 50 times the PEL (when quantitatively fit). The appropriate filter or carbon cartridge (or a combination of both) must be selected based on the contaminant(s) and their concentrations. After this first phase of selection is complete, there may be other criteria that influences the selection process. As an example, the use of acids should prompt consideration of appropriate eye/face protection or a full-face respirator should be considered.



### HALF AND FULL-FACEPIECE RESPIRATORS

The 6000 series respirators provide versatility with comfort and ease of use. These low-maintenance units are approved for use with a wide range of easily fitted cartridges and filters for particulate or gas and vapor protection NIOSH approved. Cartridges and filters sold separately.

Order # 29-00060

Item	Description	Model	Size	12+	6+	1+
A	Half-Face	6100	Small	\$18.28	\$19.35	\$21.50
B	Half-Face	6200	Medium	\$18.28	\$19.35	\$21.50
C	Half-Face	6300	Large	\$18.28	\$19.35	\$21.50
	Full-Face	6800	Medium	\$143.15	\$149.38	\$155.60

- OV = NIOSH approval:** Certain organic vapors
- AG = NIOSH approval:** Chlorine, hydrogen chloride, and sulfur dioxide or chlorine dioxide or hydrogen sulfide (escape only)
- Merc = MIOSH approval:** Mercury vapor or chlorine gas
- OV/AG = MIOSH approval:** Certain organic vapors, chlorine, hydrogen chloride, and sulfur

### P100 ORGANIC VAPOR/ACID GAS

P-100 Filter. OV/AG. 99.97% efficient aglint solid and liquid aerosols including oil. Relief from nuisance levels of acid gas.



Item	Order #	Description	Model	12+	6+	1+
D	29-0005	P100 Organic Vapor/Acid Gas	3M60923	\$21.30	\$22.22	\$23.15
E	29-0029	Organic Vapor/Acid Gas Cartridges	3M6003	\$12.47	\$13.01	\$13.55

### P100 PARTICULATE FILTER

P100 particulate filter fits -6000 series respirators. 99.97% efficient aglint solid and liquid aerosols including oil.



Item	Order #	Description	Model	12+	6+	1+
F	29-0007	P100 Particulate Filters	3M2091	\$8.59	\$9.09	\$10.10

## RESPIRATORS

Lightweight, filtering face pieces provide greater user comfort and acceptance in a wide variety of applications and certain particulates.

RESPIRATOR SELECTION PROCESS: Under NIOSH 42 CFR 84, there are nine classes of filters comprised of three levels of minimum filter efficiency and three categories of the resistance to the effects of oil in the workplace. The three levels of filtration efficiency are 95%, 99%, and 97% (100) against the most difficult particle size to filter. The three categories of resistance to the effect of oil are N-Not resistant to oil, R-Resistant to oil, P-Oil-Proof.

### MOLDEX RESPIRATORS

- A. NIOSH Rating: R95. Applications: soldering, braising, torch cutting, metal pouring, polishing, and buffing.
- B. NIOSH Rating: R95. Applications: welding, cutting, and metal pouring.
- C. NIOSH Rating: R95. Applications: grinding and sanding.

Order # 29-00190

Item	Model	Size	Per Box	12+	6+	1+
A	2740	Medium/Large	10	\$37.67	\$39.31	\$40.95
B	2730	Medium/Large	5	\$39.79	\$41.52	\$43.25
C	8511	Universal	10	\$22.86	\$23.86	\$24.85



### 3M® RESPIRATORS

- D. NIOSH Rating: N95. Applications: welding, soldering, cutting, grinding, and sanding.
- E. NIOSH Rating: N95. Applications: welding, soldering, and where metal fumes are present.
- F. NIOSH Rating: N95. Applications: welding, metal pouring, and work involving exposure in concentrations of up to 10X.

Order # 29-00030

Item	Model	Size	Per Box	12+	6+	1+
D	8515	Universal	10	\$31.37	\$32.74	\$34.10
E	8212	Universal	10	\$60.26	\$62.88	\$65.50
F	8233	Universal	Each	\$8.88	\$9.26	\$9.65

### 3M® RESPIRATORS

- G. Applications: grinding and sanding.
- H. NIOSH Rating: R95. Applications: sanding and polishing.
- J. NIOSH Rating: R95. Applications: where partiles and nuisance of levels of organic vapors may be present.

Order # 29-00040

Item	Model	Size	Per Box	12+	6+	1+
G	8210	Universal	20	\$23.32	\$24.34	\$25.35
H	8110S	Small	20	\$19.68	\$20.84	\$23.15
J	8247	Universal	20	\$69.41	\$72.43	\$75.45

### DIRECT SAFETY RESPIRATORS

- K. NIOSH Rating: N95. Applications: dust irritants.

### SPERIAN RESPIRATORS

- L. NIOSH Rating: N95. Applications: grinding, polishing, and sanding.
- M. NIOSH Rating: N95. Applications: welding, soldering, braising, grinding, sanding, metal machining, polishing, and buffing.

Order # 29-00450

Item	Model	Size	Per Box	12+	6+	1+
K	8610/8615	Universal	20	\$12.56	\$13.10	\$13.65
L	14110391F	Medium/Large	20	\$23.64	\$24.67	\$25.70
M	2207	Medium/Large	20	\$23.89	\$25.29	\$28.10





**SAFETY GLASSES**

A. Adjustable temples allow a comfortable, custom fit. Lenses are high-impact polycarbonate. Black nylon frame is rugged but lightweight. The DX Lens coating is anti-fog, anti-scratch, anti-UV, anti-static, and has excellent chemical resistance. Complies with ANSI 287.1-1989 standards. Made in the USA.

B. Engineered with an innovative molding process that actually allows the frame to serve as a shock absorber that can diffuse and deflect impact. A ventilation channel between the frame and brow bumper directs airflow under the lens to reduce moisture build-up and fogging. Three-position ratchet lens inclination system with adjustable length temples allows you a custom fit.

C-D. Adjustable temples allow comfortable, custom fit. High-impact, polycarbonate lens has new coating for anti-fog, anti-UV, anti-static, and anti-scratch. ANSI 287.1-1989 standards.

E. Single wraparound lens design features integral side shields, metal alloy temples with rubber head grips for a custom fit, and a strong, yet lightweight, polycarbonate lens.

F. Wraparound metal frame offers both protection and style. Dual polycarbonate lens design provides built-in side protection and superior coverage. Spring hinge temples, soft rubber temple tips, and an adjustable saddle pad nosepiece produce a comfortable and secure fit with Uvextra anti-fog coating.

G. Reduce the risk of eye injury with these close-fitting, wrap-around glasses. Features a lightweight, translucent frame with ratchet hinges for adjustable, front inclination. Large, 66mm, polycarbonate lenses provide a wide field of peripheral vision. Complies with ANSI 287.1-1989 and CSA 294.3-1992 standards. Lens are welding shade 5.0. Made in the U.S.A.

**Order # 29-00300**

Item	Description	Lens Shade	Color	12+	6+	1+
A	Crews Blackjack		Clear	\$7.41	\$7.73	\$8.05
B	Direct Safety® Kavalry		Clear	\$7.59	\$7.92	\$8.25
C	Crews Storm	5.0	Green	\$8.16	\$9.18	\$10.20
D	UVEX Slate		Clear	\$9.66	\$10.08	\$10.50
E	UVEX Genesis	5.0	Green	\$16.48	\$17.87	\$19.85
F	N-SPECS®	5.0	Green	\$17.62	\$18.38	\$19.15
G	Uvex Cricket Safety Glass	3.0	Green	\$20.42	\$21.31	\$22.20



**PLATINUM SOLDERING GOGGLES**

These soldering goggles provide eye protection while soldering platinum. Approved by the Platinum Guild, these goggles are available in #5, #7, or #10 shade. The #5 and #7 shades work for soldering platinum while the #10 shade is used for melting platinum. The goggles are black, lightweight plastic with adjustable ear pieces. Complies with ANSI 287.1-1989 standards.

**Order # 29-00630**

Item	Description	12+	6+	1+
A	#5 Shade Goggle	\$15.69	\$16.37	\$17.05
B	#7 Shade Goggle	\$15.69	\$16.37	\$17.05
C	#10 Shade Goggle	\$15.69	\$16.37	\$17.05



**PLATINUM WELDING GOGGLES**

Soft, vinyl body with ventilated slots. The #10 shade provides recommended eye protection for platinum melting. Lenses are impact resistant but not unbreakable. Meets ANSI 287.1 requirements.

**Order # 29-00680**

Item	Description	12+	6+	1+
D	Welding Goggles	\$26.13	\$27.26	\$28.40
	#10 Lens for Platinum	\$6.59	\$6.98	\$7.75



**ANTI-FOG GOGGLES**

Clear, vinyl goggles come with elastic headband for firm fit. Clear frame provides excellent front and peripheral vision. Complies with ANSI 287.1-1989 standards. Made in the USA.

**Order # 29-00400**

Item	Description	12+	6+	1+
E	Cover Goggles	\$3.73	\$3.89	\$4.05
F	Fogless Lens Splash Goggles	\$4.19	\$4.37	\$4.55



**FACE SHIELD WITH VISOR**

Lightweight plastic face shield provides full-face protection when polishing, soldering, or mixing investment. Comes with adjustable vinyl head band.

**Order # 29-00130**

Item	Description	12+	6+	1+
G	Face Shield with Visor	\$26.13	\$27.26	\$28.40
	Visor Only	\$8.42	\$8.78	\$9.15





**STULLER RING CRACKER**

Allows you to crack any ceramic or tungsten ring with no pain to the wearer. Very easy to use. Anybody can assist with the removal of these alternative metals. The kit comes with a Ring Cracker, two pairs of safety glasses, and instructions. Only removes tungsten and ceramic rings.

Order #	Description	12+	6+	1+
58-2440	Ring Cracker	\$80.45	\$85.19	\$94.65



**PRE-MOISTENED LENS CLEANING TISSUES**

Pre-moistened lens cleaning tissues are great for cleaning all types of glasses and lenses.

Order #	Description	12+	6+	1+
29-4856	Lens Cleaning Tissues	\$14.63	\$15.26	\$15.90



**CORDED EARPLUGS**

Disposable hearing protectors feature convenient cord to prevent loosening. Soft, foam plug conforms and seals quickly and comfortably. Earplugs provide 29dB of sound protection. Made in the USA.

Order # 29-00150

Description	Per Box	12+	6+	1+
Corded Earplugs	Box of 10	\$3.54	\$3.70	\$3.85
Corded Earplugs	Box of 100	\$28.15	\$29.38	\$30.60



**ALLERGY JEWELRY SHIELD**

Shields sensitive skin from jewelry irritation. Gives consumers unlimited personal choice in jewelry selection. Use on all skin irritating jewelry. Prevents skin discoloration. 1/2 ounce jar. Shipping weight 0.10 lb.



Order #	Description	12+	6+	1+
29-0035	Allergy Jewelry Shield	\$6.08	\$6.44	\$7.15



**PR88 HAND PROTECTION**

Excellent hand protection keeps grease and grime from penetrating the skin. Just apply before beginning work. Washes off with soap and water.

Order # 54-4462

Item	Description	12+	6+	1+
A	1 liter container	\$28.20	\$29.42	\$30.65
B	3 1/2 oz container	\$9.15	\$9.55	\$9.95

**PREMIUM WELDING GLOVES**

Foam-lined welding gloves feature a full-cotton lining with foam lining on the palm and back for maximum comfort. The thumb has a patch and reinforced strap. Sewn with Kevlar® thread.



Order #	Description	12+	6+	1+
22-7503	Pair Welding Gloves	\$10.44	\$10.90	\$11.35



**PR88 HAND PROTECTION**

Heat-resistant welding gloves feature an inner layer of aluminized Mylar® film that protects the back of the hand from radiant heat. Designed for the ultimate in comfort, wear, and protection, the Mylar film sits between a full-foam lining and a premium, side-split cowhide leather shell. Has double reinforced palm and thumb.



Order #	Description	12+	6+	1+
22-7502	Pair Welding Gloves	\$13.80	\$14.40	\$15.00



**DELUXE WELDERS GLOVES**

Manufactured from 22-ounce, basket-weave Kevlar Plus, the glove material offers superior abrasion and cut resistance due to Kevlar, which is blended with nomex and fiberglass. Can be used in applications up to 800°F (426.7°C), or up to 1,000°F (537.8°C) for brief contact. Glove linings are standard heavyweight 100% wool. Features extra-wide cuff openings that allow the gloves to be dropped with a flick of the wrist in case of molten splash or excess heat buildup. 14" long.



Order #	Description	12+	6+	1+
22-7500	Pair Wool-Lined Gloves	\$50.78	\$52.99	\$55.20



**KEVLAR KNIT GLOVES**

Providing exceptional cut resistance, Kevlar seamless knit gloves are constructed for long life. Sold by the pair.



Order #	Description	12+	6+	1+
22-7506	Pair Knit Gloves	\$7.87	\$8.21	\$8.55



**NEOPRENE GLOVES**

Black neoprene 14" coated gloves with knit lining provide superior quality and durability as well as protection against acids, caustics, oils, greases, and many solvents. Excellent all-around protection for plating. One size fits all.



Order #	Description	12+	6+	1+
22-7508	Neoprene Gloves	\$15.69	\$16.37	\$17.05



**GLOVES**

Use these gloves for clean work, assembly, light manufacturing, delicate tool and instrument applications, or anywhere extreme dexterity is required. Gloves are constructed of a seamless nylon shell dipped in nitrile coating. Gloves feature more nitrile than similar gloves, producing greater wear, improved tact, a better grip, and more cut protection. Nitrile Coated Gloves have more abrasion resistance and longer wear.



Item	Order #	Description	Size	12+	6+	1+
A	22-7511	Nitrile Coated Gloves	Small	\$3.12	\$3.56	\$4.45
B	22-7512	Nitrile Coated Gloves	Medium	\$4.03	\$4.60	\$5.75



Safety Supplies

Safety Supplies





**DISPOSABLE LATEX GLOVES**

These high-grade, expandable latex gloves are thin to allow good finger sensitivity and excellent dexterity but are tough enough to protect your hands from dirt, grit, and harsh chemicals. Excellent to use during buffing or polishing. Gloves fit either hand.

Order # 17-07450

Description	12+	6+	1+
Small Disposable Latex Gloves	\$13.89	\$14.50	\$15.10
Medium Disposable Latex Gloves	\$13.89	\$14.50	\$15.10
Large Disposable Latex Gloves	\$13.89	\$14.50	\$15.10



**POWDER-FREE BLUE NITRILE GLOVES**

Offer better tactile sensitivity, comfort, dexterity, and puncture resistant than rubber or vinyl. These powder-free gloves are made stronger through a process called fusion bonding, which integrates synthetic polymers into the material to create a multi-layer glove or enhanced protection. Measures 4.4 mil (palm) and 4.7 mil (fingers) thickness/9½" length.

Order # 17-0846



Size	12+	6+	1+
Blue Nitrile Gloves	\$13.94	\$14.54	\$15.15
Blue Nitrile Gloves	\$13.94	\$14.54	\$15.15
Blue Nitrile Gloves	\$13.94	\$14.54	\$15.15
Blue Nitrile Gloves	\$13.94	\$14.54	\$15.15



**RUBBER GLOVES**

Use these replacement gloves with the glass bead blasters.



Order #	Description	Length	12+	6+	1+
23-0043	Unlined	18"	\$24.89	\$26.35	\$29.28



**FIRST AID KIT**

Be prepared. New first aid kits treat wounds and save lives. Discover the best value in first aid kits in this new Northern Kit that lets you set up a first aid station instantly, anywhere. Premium quality contents treat up to 25 people. Six partitioned areas keep contents organized. Features convenient molded carry handle.

Order #	Description	1+
29-0100	First Aid Kit	\$23.90

**LEATHER WELDING APRON**

Leather welding aprons are made of side-split leather and sewn together with Kevlar® thread for extra strength. The apron features a comfortable strap assembly with a quick release buckle. Comes with a two-compartment chest pocket.

Item	Order #	W×L	12+	6+	1+
A	47-3067	24"×36"	\$29.30	\$30.58	\$31.85

**NEOPRENE PLATING APRON**

Durable neoprene apron is designed to protect against chemical spills during plating and other applications.

Item	Order #	W×L	12+	6+	1+
B	47-3068	36"×43"	\$18.58	\$19.39	\$20.20

**FIRE RETARDANT APRON**

Designed for the working jeweler by a working jeweler with 30 years experience. The apron material is a highly burn-resistant fabric. When hot metal is dropped on it, it leaves a barely noticeable scorch mark. It's a smooth fabric that will not lose its fire-retardant qualities even after many launderings. The top of the apron was designed to be wider, to protect more of the neck and chest, and has an adjustable neck strap that won't get stuck in long hair, as velcro will. The tie straps are long to wrap around and tie in front. The apron is 36" long to cover the lap adequately when sitting, and has a little flap at the bottom to catch runaway parts or metal filings falling into the apron.

Item	Order #	Length	12+	6+	1+
C	47-3065	38"	\$28.11	\$29.33	\$30.55



**BRADLEY® FAUCET-MOUNTED EYE WASH**

Mount this eye wash to both standard and gooseneck faucets. No special plumbing is required. Integral flow control assures a steady flow of water under varying water supply conditions. Unit is constructed of chrome-plated brass and comes standard with an adapter, diverter, twin sprayheads, and pop-off plastic dust caps. Note: To eliminate the risk of scalding eyes during use, it is recommended that the hot water supply to the faucet be disconnected or that tempered water be provided.

Item	Order #	Description	1+
D	29-0101	Faucet-Mounted Eye Wash	\$72.50



**EYE-WASH-STATION VISI-SIGNS SIGN**

Offering 180° visibility, this three-dimensional mounted design projects 3½" out from the wall at a 45° angle, making your message seen from all sides. The 5¾" x 8¾" sign is constructed of 0.125 acrylic with pre-drilled mounting holes.

Item	Order #	Description	1+
E	29-0102	Eye-Wash-Station Visi-Signs Sign	\$21.25



Safety Supplies

Safety Supplies



# SAW BLADES AND FRAMES



## SAWING PRACTICES

The jeweler's sawblade is mounted in the saw frame, under tension, with the teeth pointing downward toward the handle. The simplest way to set the tension for the blade is to adjust the length of the frame so that one end of the blade is set to the bottom of the clamp and the end of the blade is centered on the thumbscrew of the other clamp. This will allow the frame to be sprung inward from 1/4" to 1/2" to set the proper tension on the blade. Smaller sized blades will require less tension than the larger sizes.

There are two main types of sawing action, severing and contour sawing (this includes piercing). Severing is the process of cutting a piece off or separating parts (such as when sizing a ring) in a straight line. Flat sawblades are the best choice for this process because they generally track straighter due to their design. For contour cutting, piercing sawblades are preferred. In choosing the proper size saw blade for the most efficient cutting, the thickness of the material to be cut should be taken into consideration.

Ideally, there should always be between 3 and 5 teeth in contact with the thickness of the metal. If less than 3 teeth are in contact, the cut becomes ragged and the blade has a tendency to grab. If more than 5 teeth contact the metal, the cutting process is unnecessarily slowed. Sawing is generally done with the blade at a right angle to the work. This is especially important for contour cutting. For cutting straight lines, the blade can be tilted ever-so-slightly forward (5° to 15°) to aid in tracking. Although not required, lubricating the blade prior to and during the sawing process will extend the blade life as well as enhance the cutting action.

Order # 49-00002 Sold by the gross. (144 per unit)

Blade Size	Per Unit	12+	6+	1+
4/0	Gross	\$21.89	\$23.18	\$25.75
3/0	Gross	\$20.19	\$21.38	\$23.75
2/0	Gross	\$20.19	\$21.38	\$23.75
1/0	Gross	\$20.19	\$21.38	\$23.75
#1	Gross	\$20.19	\$21.38	\$23.75
#2	Gross	\$20.19	\$21.38	\$23.75
#3	Gross	\$20.19	\$21.38	\$23.75
#4	Gross	\$20.19	\$21.38	\$23.75

Sold by the dozen. (12 per unit)

Blade Size	Per Unit	12+	6+	1+
3/0	Dozen	\$20.19	\$21.38	\$23.75
4/0	Dozen	\$3.49	\$3.69	\$4.10
2/0	Dozen	\$3.49	\$3.69	\$4.10
1/0	Dozen	\$3.49	\$3.69	\$4.10
#1	Dozen	\$3.49	\$3.69	\$4.10
#2	Dozen	\$3.49	\$3.69	\$4.10
#3	Dozen	\$3.49	\$3.69	\$4.10
#4	Dozen	\$3.49	\$3.69	\$4.10

### PIKE® PLATINUM SAW BLADES

This saw blade was specially designed to offer incomparable resistance to wear when cutting platinum stainless steel and all hard metals. It allows for a clean precise cut requiring a minimum of effort and providing considerably improved sawing comfort. The filed teeth guarantee a cutting capacity unequalled by any other process using a special high quality steel. Exclusive heat processes endow our blades with a tenacity and flexibility without comparison. Note: 4/0 is smallest size #4 is largest.



Order # 49-00001 Sold by the gross. (144 per unit)

Blade Size	Per Unit	12+	6+	1+
8/0	Gross	\$25.20	\$26.69	\$29.65
7/0	Gross	\$23.33	\$24.71	\$27.45
6/0	Gross	\$21.46	\$22.73	\$25.25
5/0	Gross	\$20.53	\$21.74	\$24.15
4/0	Gross	\$18.66	\$19.76	\$21.95
3/0	Gross	\$16.79	\$17.78	\$19.75
1/0	Gross	\$16.79	\$17.78	\$19.75
#1	Gross	\$16.79	\$17.78	\$19.75
#2	Gross	\$16.79	\$17.78	\$19.75
#3	Gross	\$16.79	\$17.78	\$19.75
#4	Gross	\$16.79	\$17.78	\$19.75
#5	Gross	\$20.53	\$21.74	\$24.15
#6	Gross	\$21.46	\$22.73	\$25.25
#8	Gross	\$24.27	\$25.70	\$28.55
#10	Gross	\$26.56	\$28.13	\$31.25
#12	Gross	\$31.28	\$33.12	\$36.80
#14	Gross	\$34.09	\$36.09	\$40.10

Sold by the Dozen (12 per unit)

Blade Size	Per Unit	12+	6+	1+	Blade Size	Per Unit	12+	6+	1+	Blade Size	Per Unit	12+	6+	1+
8/0	Dozen	\$3.74	\$3.96	\$4.40	2/0	Dozen	\$2.81	\$2.97	\$3.30	#5	Dozen	\$3.06	\$3.24	\$3.60
7/0	Dozen	\$3.74	\$3.96	\$4.40	1/0	Dozen	\$2.39	\$2.53	\$2.81	#6	Dozen	\$3.40	\$3.60	\$4.00
6/0	Dozen	\$3.74	\$3.96	\$4.40	#1	Dozen	\$2.81	\$2.97	\$3.30	#8	Dozen	\$3.57	\$3.78	\$4.20
5/0	Dozen	\$3.40	\$3.60	\$4.00	#2	Dozen	\$2.81	\$2.97	\$3.30	#10	Dozen	\$4.34	\$4.59	\$5.10
4/0	Dozen	\$2.72	\$2.88	\$3.20	#3	Dozen	\$2.81	\$2.97	\$3.30	#12	Dozen	\$4.68	\$4.95	\$5.50
3/0	Dozen	\$2.81	\$2.97	\$3.30	#4	Dozen	\$2.81	\$2.97	\$3.30	#14	Dozen	\$5.06	\$5.36	\$5.95

### PIKE® GOLD SAW BLADES

Tried and tested at Stuller. Premium Swiss-made saw blades. Note: 8/0 is smallest size #14 is largest.



### SUPER PIKE® SAW BLADES

**Good old regular Swiss:** This is the equivalent to Pike or any other of our blades. Strong but flexible gold color very sharp teeth round back long lasting. The reference of quality in the market.

**Super Pike:** The blade is produced exactly the same except for the heat treatment process. It makes the blade harder but not more fragile. It lasts longer and stays sharper longer. It also has a thin coat, making it more comfortable to use.

**Platinum:** The steel we use here is different and the blade is harder which also means more brittle. But it allows to saw harder materials than the most common in the jewelry industry.

Order # 49-4230 Sold by the gross. (144 per unit)

Blade Size	Per Unit	12+	6+	1+
8/0	Gross	\$25.50	\$27.00	\$30.00
7/0	Gross	\$25.50	\$27.00	\$30.00
6/0	Gross	\$24.65	\$26.10	\$29.00
5/0	Gross	\$24.65	\$26.10	\$29.00
4/0	Gross	\$24.65	\$26.10	\$29.00
3/0	Gross	\$24.65	\$26.10	\$29.00
2/0	Gross	\$24.65	\$26.10	\$29.00
#0	Gross	\$24.65	\$26.10	\$29.00
#1	Gross	\$24.65	\$26.10	\$29.00
#2	Gross	\$24.65	\$26.10	\$29.00
#3	Gross	\$24.65	\$26.10	\$29.00
#4	Gross	\$24.65	\$26.10	\$29.00
#5	Gross	\$24.65	\$26.10	\$29.00
#6	Gross	\$24.65	\$26.10	\$29.00
#8	Gross	\$24.65	\$26.10	\$29.00

Note: 7/0 is smallest size, #8 is largest.







**STULLER® PREMIUM SWISS SAW BLADES**  
Genuine, premium Swiss-made saw blades made to our exacting standards.

Note: 5/0 is smallest size, #5 is largest.



**Order # 49-00000** Sold by the gross. (144 per unit)

Blade Size	Per Unit	12+	6+	1+
5/0	Gross	\$18.66	\$19.76	\$21.95
4/0	Gross	\$18.66	\$19.76	\$21.95
3/0	Gross	\$18.66	\$19.76	\$21.95
2/0	Gross	\$18.66	\$19.76	\$21.95
1/0	Gross	\$18.66	\$19.76	\$21.95
#1	Gross	\$18.66	\$19.76	\$21.95
#2	Gross	\$18.66	\$19.76	\$21.95
#3	Gross	\$18.66	\$19.76	\$21.95
#4	Gross	\$18.66	\$19.76	\$21.95
#5	Gross	\$18.66	\$19.76	\$21.95

Sold by the dozen. (12 per unit)

Blade Size	Per Unit	12+	6+	1+
5/0	Dozen	\$2.72	\$2.88	\$3.20
4/0	Dozen	\$2.72	\$2.88	\$3.20
3/0	Dozen	\$2.72	\$2.88	\$3.20
2/0	Dozen	\$2.72	\$2.88	\$3.20
1/0	Dozen	\$2.72	\$2.88	\$3.20
#1	Dozen	\$2.72	\$2.88	\$3.20
#2	Dozen	\$2.72	\$2.88	\$3.20
#3	Dozen	\$2.72	\$2.88	\$3.20
#4	Dozen	\$2.72	\$2.88	\$3.20
#5	Dozen	\$2.72	\$2.88	\$3.20

**Order # 49-00003** Sold by the gross. (144 per unit)

Blade Size	Per Unit	12+	6+	1+
8/0	Gross	\$27.07	\$28.67	\$31.85
7/0	Gross	\$26.14	\$27.68	\$30.75
6/0	Gross	\$23.33	\$24.71	\$27.45
5/0	Gross	\$22.40	\$23.72	\$26.35
4/0	Gross	\$20.53	\$21.74	\$24.15
3/0	Gross	\$18.66	\$19.76	\$21.95
2/0	Gross	\$18.66	\$19.76	\$21.95
1/0	Gross	\$18.66	\$19.76	\$21.95
#1	Gross	\$18.66	\$19.76	\$21.95
#2	Gross	\$18.66	\$19.76	\$21.95
#3	Gross	\$18.66	\$19.76	\$21.95
#4	Gross	\$18.66	\$19.76	\$21.95
#5	Gross	\$20.53	\$21.74	\$24.15
#6	Gross	\$22.40	\$23.72	\$26.35
#7	Gross	\$3.61	\$3.83	\$4.25
#8	Gross	\$27.84	\$29.48	\$32.75
#10	Gross	\$29.33	\$31.05	\$34.50
#12	Gross	\$38.68	\$40.95	\$45.50
#14	Gross	\$5.74	\$6.08	\$6.75

Sold by the dozen. (12 per unit)

Blade Size	Per Unit	12+	6+	1+
6/0	Dozen	\$3.61	\$3.83	\$4.25
5/0	Dozen	\$3.44	\$3.65	\$4.05
4/0	Dozen	\$3.44	\$3.65	\$4.05
3/0	Dozen	\$3.15	\$3.33	\$3.70
2/0	Dozen	\$3.15	\$3.33	\$3.70
1/0	Dozen	\$3.15	\$3.33	\$3.70

Blade Size	Per Unit	12+	6+	1+
#1	Dozen	\$3.15	\$3.33	\$3.70
#2	Dozen	\$3.15	\$3.33	\$3.70
#3	Dozen	\$3.15	\$3.33	\$3.70
#4	Dozen	\$3.15	\$3.33	\$3.70
#5	Dozen	\$3.44	\$3.65	\$4.05
#6	Dozen	\$3.44	\$3.65	\$4.05

Blade Size	Per Unit	12+	6+	1+
#7	Dozen	\$3.61	\$3.83	\$4.25
#8	Dozen	\$3.83	\$4.05	\$4.50
#10	Dozen	\$4.21	\$4.46	\$4.95
#12	Dozen	\$4.68	\$4.95	\$5.50
#14	Dozen	\$5.74	\$6.08	\$6.75

**Order # 49-00004** Sold by the gross. (144 per unit)

Blade Size	Per Unit	12+	6+	1+
8/0	Gross	\$23.33	\$24.71	\$27.45
7/0	Gross	\$21.46	\$22.73	\$25.25
6/0	Gross	\$19.59	\$20.75	\$23.05
5/0	Gross	\$18.66	\$19.76	\$21.95
4/0	Gross	\$16.79	\$17.78	\$19.75
3/0	Gross	\$15.85	\$16.79	\$18.65
2/0	Gross	\$15.85	\$16.79	\$18.65
1/0	Gross	\$15.85	\$16.79	\$18.65
#1	Gross	\$15.85	\$16.79	\$18.65
#2	Gross	\$15.85	\$16.79	\$18.65
#3	Gross	\$15.85	\$16.79	\$18.65
#4	Gross	\$15.85	\$16.79	\$18.65
#5	Gross	\$18.66	\$19.76	\$21.95
#6	Gross	\$19.59	\$20.75	\$23.05
#8	Gross	\$22.40	\$23.72	\$26.35
#10	Gross	\$32.34	\$34.25	\$38.05

**SKIP-A-TOOTH SAW BLADES**

These blades are designed for wax cutting. Every other tooth is eliminated, which provides smooth cutting and non-loading action.

Sold by the gross. (144 per unit)

Order #	Blade Size	Per Unit	12+	6+	1+
49-3008	1	Gross	\$2.76	\$2.93	\$3.25

**SPIRAL SAW BLADES**

Used to cut rubber, plastic, wax, and plaster. Cut in any direction.

**Order # 49-00005** Sold by the dozen. (12 per unit)

Item	Blade Size	Per Unit	12+	6+	1+
A	#2	Dozen	\$3.23	\$3.42	\$3.80
B	#3	Dozen	\$3.23	\$3.42	\$3.80
C	#4	Dozen	\$3.23	\$3.42	\$3.80
D	#6	Dozen	\$3.23	\$3.42	\$3.80

**YELLOW DAGGER SAW BLADES**

Swiss-made these saw blades provide great performance not normally seen in this price range.

Note: 8/0 is smallest size #14 is largest.



**DIAMOND-COATED SAW BLADES**

Made by electroplating diamond particles onto piano wire, our diamond-coated saw blades are the best quality available at prices well below the competition. They offer a generous supply of diamond, ensuring long life and quick cutting. Blades come individually packaged and are 5 3/8" to fit existing saw frames. Great for glass, ceramic, and stones. Sold each.

**Order # 49-00006**

Item	Grit	Grade	12+	6+	1+
E	60	Coarse	\$8.42	\$8.91	\$9.90
F	100	Medium	\$8.42	\$8.91	\$9.90
G	120	Medium	\$8.42	\$8.91	\$9.90
H	140	Fine	\$8.42	\$8.91	\$9.90



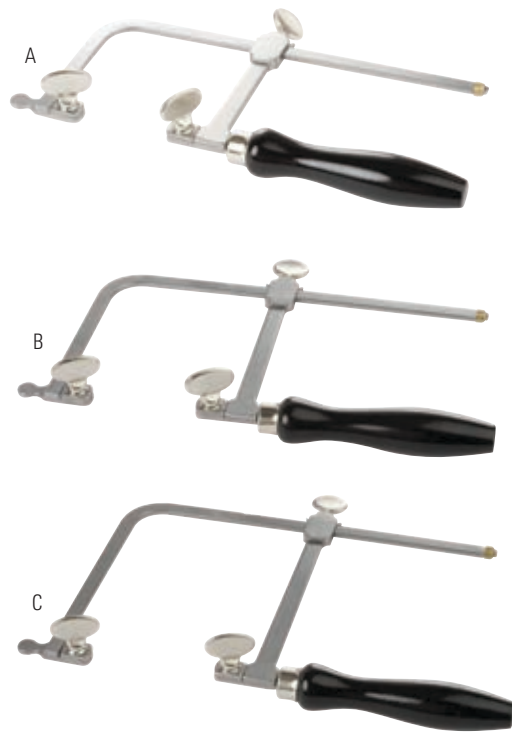

**ADJUSTABLE SAW FRAMES**

For use with piercing, flat, and spiral saw blades. Serrated clamps hold blades firmly. Strongly constructed with flat steel frames, hardwood handles, and thumbscrew locking devices. Most common depth is 2 1/4" (57mm). Others are used when greater cutting depth is required.

Item	Order #	Description	Blade Size	12+	6+	1+
A	49-7230	Frame	3"	\$8.08	\$8.55	\$9.50
B	49-7235	Frame	4"	\$8.08	\$8.55	\$9.50
C	49-7240	Frame	5"	\$10.84	\$11.48	\$12.75
REPLACEMENT PARTS						
	49-7245	Wing-Screw (Holds Blades)		\$1.66	\$1.76	\$1.95
	49-7246	Blade Block-Nut Pad-Washer & Wing-Nut		\$6.33	\$6.71	\$7.45
	49-7251	Saw Handle		\$1.66	\$1.76	\$1.95

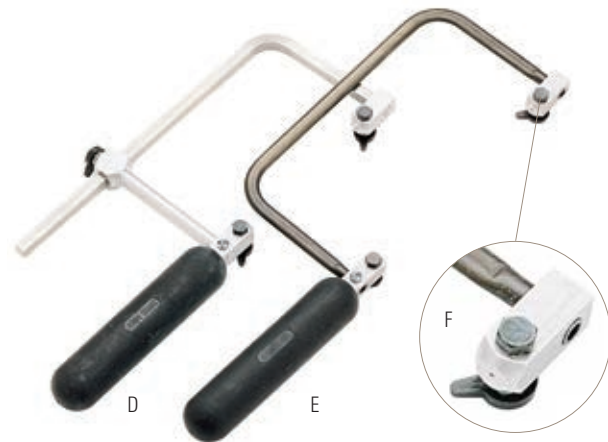

**SWISS SAW FRAMES**

Revolutionary new design in two lightweight perfectly balanced saw frames. Ergonomic handles reduce fatigue and provide dexterity. Patented blade-lock design eases blade insertion maintains perfect alignment and eliminates wobble. This helps reduce blade loss during use. Set screws can be used on either left or right side. Genuine Swiss-made.

Item	Order #	Description	Blade Size	12+	6+	1+
D	49-7200	Adjustable Frame	2 3/4"	\$13.90	\$14.72	\$16.35
E	49-7220	Fixed Frame	2 3/4"	\$13.90	\$14.72	\$16.35
F	49-7221	Replacement Screw		\$4.63	\$4.91	\$5.45



Find added video content on [Stuller.com/VideoCenter](http://Stuller.com/VideoCenter).

**MINI SAW FRAME**

These handy mini frames provide control for delicate operations such as gem cutting or making relief cuts on prongs that have been partially folded over stones. Their small size and light weight give the handler a better feel for what is being cut. The frames support standard blades or your broken blades if they break long enough. To insert a new blade, spring the saw slightly with your hand, or push one end against your bench. These frames can also be used with abrasive film cut to the proper length.

Item	Order #	Description	Per Pack	12+	6+	1+
	49-7213	Mini Saw Frame Kit	Set of 3	\$21.25	\$22.50	\$25.00
G	49-7211	Blue Saw Frame	Each	\$8.46	\$8.96	\$9.95
H	49-7210	Red Saw Frame	Each	\$8.46	\$8.96	\$9.95
J	49-7212	Yellow Saw Frame	Each	\$8.46	\$8.96	\$9.95

**TUBE CUTTER JIG**

Reinforced hardened steel blade with contoured wooden handle. Fine tooth back saw blade is excellent for cutting metal rods and tubing. Also useful for cross cutting, trimming, and notching light metals. Holds tubing up to 6mm round or 7.5mm square. Made in the USA.

Item	Order #	Description	12+	6+	1+
A	58-2462	Tube Cutter Jig Economy	\$22.10	\$23.40	\$26.00
B	58-2465	Tube Holder	\$36.51	\$38.66	\$42.95

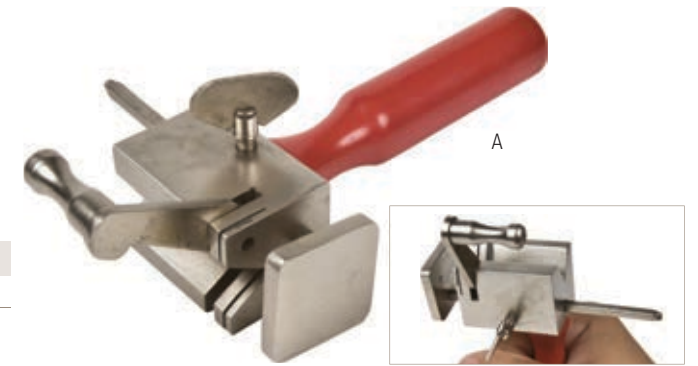

**TUBE CUTTER**

Tube cutter with four angles – 30, 45, 60, and 90 degrees. The cutter is hardened to HRC 45 with a removable handle, so that it can be mounted in a vice. The thumb lock ensures a good grip on the material being cut and the adjustable slide/stop can be set with the lock screw making repeated lengths of cut easy. A deep V groove holds the material firmly in place.

Item	Order #	Description	12+	6+	1+
C	58-2470	Tube Cutter	\$102.00	\$108.00	\$120.00



**BACK SAW FOR METALS**

Reinforced hardened steel blade with contoured wooden handle. Fine tooth back saw blade is excellent for cutting metal rods and tubing. Also useful for cross cutting, trimming, and notching light metals. Made in the USA.

Item	Order #	Overall Length	Blade Length	12+	6+	1+
D	49-4300	9 1/2"	5"	\$5.61	\$5.94	\$6.60



1mm = 0.0400 inch

Size	Piercing Saw Blades			Flat Saw Blades	
	Thickness	Width	Drill Size	Thickness	Width
8/0	0.0063	0.0126	80	—	—
7/0	0.0067	0.0130	80	—	—
6/0	0.0070	0.0140	79	—	—
5/0	0.0080	0.0157	78	—	—
4/0	0.0086	0.0175	77	—	—
3/0	0.0095	0.0190	76	—	—
2/0	0.0130	0.0204	75	—	—
1/0	0.0110	0.0220	75	—	—
0	0.0110	0.0230	73	—	—
1	0.0120	0.0240	74	0.0070	0.0290
2	0.0134	0.0276	70	0.0080	0.0340

Size	Piercing Saw Blades			Flat Saw Blades	
	Thickness	Width	Drill Size	Thickness	Width
3	0.0140	0.0290	70	0.0080	0.0370
4	0.0150	0.0307	68	0.0080	0.0430
5	0.0158	0.0331	65	0.0080	0.0510
6	0.0173	0.0370	58	0.0080	0.050
7	0.0189	0.0400	56	0.0080	0.0570
8	0.0197	0.0400	55	0.0086	0.0750
9	—	—	—	0.0086	0.0830
10	0.0215	0.0510	51	0.0086	0.0950
11	—	—	—	0.0086	0.1060
12	0.0236	0.0650	51	0.095	0.1180
14	0.0236	0.0690	50	—	—

All items are priced at jeweler's cost, are sold each, unless otherwise noted, and are subject to change without notice. Visit [Stuller.com](http://Stuller.com) for our complete product selections, current pricing, and quantity price breaks. | 525



# SCALES



Items shown on scale are not included.

### A&D HR SERIES

- Diamond scale
- HR-60 is legal-for-trade, class II
- Large weighing chamber holds up to a 250mm volumetric flask
- Wide angle LCD display
- Good Laboratory Practices [GLP] Software
- Multifunctional weighing: gram, troy ounce, pennyweight, pound, ounce, and grain
- Separate, clearly marked operating keys
- Full range tare
- Counting Function: Maximizes accuracy with Automatic Counting Accuracy Improvement Function [ACAI]
- Push-button calibration
- Front key selectable weighing filters: Ensures fast and stable results in all environmental conditions without switching off the balance
- Digital tare
- Outputs serial number of the balance: Identifies stolen balance and greatly reduces capital goods inventory control
- Enter balance's ID number for GLP records and identifying the balance
- Body and frame constructed of extra strong die-cast aluminum alloy
- Percentage and counting modes
- Digital preset tare
- One-touch printing
- Last digit suppression
- GLP/LIMS/ISO compliant
- Five-year warranty

Order #	Model	Trade Legal	1+
51-4076	HR-60	Y	\$1,299.00

Model	Carat	Gram	Troy Ounce	Pennyweight	Grain
HR-60	300 × 0.001	60 × 0.001	1.9 × 0.000005	38 × 0.0001	925 × 0.002

# SCALES



### A&D FX SERIES

- Compact SHS (Super Hybrid Sensor) one second stabilization
- Quick USB interface (FXi-02)
- Standard RS-232C interface
- Comparator function
- Digital calibration function
- LAN-Ethernet interface (FXi-08) with WINCT-Plus Software
- Five-year limited manufacturer's warranty

Order # 51-40740

Item	Model	Pan Size	Trade Legal	1+
A	FX-300GD	5.1"	N	\$695.00
B	FX-120GD	5.1"	N	\$639.00
C	FX-300IN	5.1"	Y	\$516.75

Model	Carat	Gram
FX-600CT	600 × 0.001	120 × 0.001
FX-120GD	610 × 0.001	122 × 0.001
FX-300GD	1600 × 0.005	320 × 0.001
*FX-300IN	300 × 0.01	—



Items shown on scales are not included.

Minnesota and Canada Legal

### TANITA™ SCALE 1230 CARAT SCALE

- 100-carat capacity with 0.1 carat readability (20g x 0.002g)
  - Weighs in carat, gram, pennyweight, and grain
  - Large, easy-to-read five digit LCD display
  - Simple, automatic calibration with included 20g calibration weight
  - Programmable automatic power off (0 to 60 seconds)
  - Energy-saving feature saves batteries
  - Overload indicator
  - Large transparent lid protects balance
  - 4.5cm platform
  - Dimensions: 15.5 x 8.4 x 2.8cm
  - Three-year manufacturer's warranty
- Specifications
- Capacity: 100 carat
  - Accuracy: Carat 0-50/0-100ct 0.01ct. Troy ounces 0-0.32toz. 0.0001toz. Grain 0-154gn 0.05gn Gram 0-1
  - Measures 6" x 4 1/2" x 1"

Order #	Model	Capacity	Scale	1+
51-2005	1230	100 g	0.1	\$263.95



### GEMORO® PLATINUM PCT 101 CARAT SCALE

- Gram, pennyweight, ounce, troy ounce, carat, and grain
- Parts counting function
- Large stainless steel weighing platform and bright blue backlit display
- Push-button digital calibration, tare, memory, low battery indicator, and battery saving auto-off functions
- Innovative low profile tinted draft shield manually expands for weighing large diamonds, gemstones, and parcels
- Durable ABS construction with UltraGrip rubberized paint finish
- Includes a rubberized protective travel/storage case with compartments containing scale, stainless steel calibration weight, stainless steel weighing platform, scoop, AC adapter, and Swiss-style locking diamond tweezers
- Powered by four long-life AAA batteries (included) or its universal voltage 100-240V AC adapter (supplied)
- Five-year limited replacement warranty

Item	Order #	Model	Capacity	Scale	12+	6+	1+
D	51-2075	PCT101	100	0.005	\$67.96	\$71.96	\$79.95
E	51-2076	PCT251	250	0.005	\$84.96	\$89.96	\$99.95



Find added video content on Stuller.com/VideoCenter.

Items shown on scales are not included.





**A&D EVEREST SERIES**

- Gold and precious stones scales
- Multiple weighing units: (carat, gram, troy ounce, pennyweight, pound, ounce, grain, and tael)
- Large LCD display (16mm height) with backlight
- Control zero, mode selection, and data output with standard RS-232C
- Counting function with Automatic Counting Accuracy Improvement
- Standard comparator function--HI/OK/LO annunciator
- Full digital calibration with optional user definable mass setting
- Conformity to GLP with I.D. and serial number outputs
- Auto power off
- Portable compact size, lightweight, rugged body
- Sealed key panel protection against dust and spills
- Low profile and small footprint for minimal space requirement
- Optional battery pack
- Overload protection
- Underhook weighing
- Security ring to prevent theft
- Stainless steel weighing pan

Item	Order #	Model	Pan Size	Trade Legal	1+
A	51-4068	EK-610J	4.3"	Y	\$917.00
B	51-4072	EK-1200i	5.2"	Y	\$299.00
	51-4072	AC Adapter			\$40.00

Model	Carat	Gram	Troy Ounce	Pennyweight	Pound	Grain
EK-610j	3000×0.1	600×0.01	19.29×0.001	385.81×0.01	1.2338×0.0001	9259.4×0.2
EK-1200i	6000×0.5	1200×0.1	38.58×0.005	771.6×0.1	2.6455×0.0005	18518×2
EK-6100j	3000×1	6100×0.01	192.90×0.01	3858.1×0.1	13.228×0.001	9259.4×2



**A&D EJ SERIES SCALE**

The EJ Newton precision compact balances offer a multitude of features for a diverse variety of weighing applications.

- LCD display with backlight
- Percentage and counting
- Full digital calibration
- AC power or alkaline battery operation (batteries not included)
- RS232C and USB output optional
- Five-year warranty
- Not trade legal

**Order # 51-40800**

Item	Model	Capacity	Readability	12+	6+	1+
C	EJ-2000	2100 g	0.1 g	—	—	\$199.19
D	EJ-120	120 g	0.01 g	\$216.75	\$229.50	\$255.00

**Kit Order # 51-40810**

E. EJ-120 Scale with Density Kit

12+	\$291.93
6+	\$309.11
1+	\$343.45

**CITIZEN™ HIGH PERFORMANCE SCALES**

- A. • HBM high-precision strain gauge load cell
- Rugged construction with stainless steel platform
  - Auto zero tracking, auto calibration
  - Backlit LCD display
  - Standard RS232C interface
  - Various weighing units include carat, gram, pennyweight, ounce, grain, pound, and troy ounce
  - A 110V AC adapter or six AA batteries (not included)



- B. • Fastest response time with highly stable reading
- Standard SR232 interface
  - Large backlit LCD display for easy viewing
  - Parts counting units include carat, gram, pennyweight, ounce, grain, pound, and troy ounce
  - Die-cast aluminium design for long-term stability and accurate results
  - Specially designed for diamond weighing



**Order # 51-21080**

Item	Model	Capacity	Readability	12+	6+	1+
A	CT1202	1200 g	0.01 g	\$318.75	\$337.50	\$375.00
B	CT603	600 g	0.001 g	—	—	\$895.50

**CITIZEN™ HIGH-PERFORMANCE DIAMOND BALANCE**

Citizen's new and improved precision series incorporates unique and unequalled high-end technology built to match the highest international standards. The result is a ten-fold increase in weighing performance, which maintains our proven, simple, and easy-to-use operator interface. Attractive quality of this new design is demonstrated by the CZ mark of conformity.

- Compact and space saving
- Standard RS232C interface data output
- Backlite LCD display for easy viewing function
- Six different weighing units (grams, pounds, ounces, carat, pennyweight, troy ounce)
- Piece counting and percentage weighing function
- CZ1200 and CZ1202 are legal for trade
- With AC adapter

**Order # 51-21050**

Item	Model	Capacity	Readability	12+	6+	1+
C	CZ602	600 g	0.01 g	\$322.15	\$341.10	\$379.00
	CZ1200	1200 g	0.1 g	\$265.80	\$281.43	\$312.70
D	CZ1202	1200 g	0.01 g	—	—	\$689.00

\*Grams only legal in USA and Canada. Legal to 0.1 gram.



**CITIZEN™ HIGH PERFORMANCE COMPACT SCALES**

These jewelry scales have hinged wind screens, stainless steel platform, and a lid display. They include a case, an adapter, scoop, and individual weight.

- Multiple weighing units include carat, gram, pieces, ounce, pennyweight, troy ounce, and grain
- Integrated overload protection that protects in transport
- Fastest response time with highly stable reading
- Fully automatic calibration for 100% accuracy

**Order # 51-21060**

Item	Model	Capacity	Readability	12+	6+	1+
E	CB30	30/150 g	0.01 g	—	—	\$195.00
	CB100	100 g	0.002 g	\$247.78	\$262.35	\$291.50







**GEMORO® PLATINUM PRO 6000**

- Pennyweight, troy ounce, ounce, and pound
- Push-button digital calibration, tare, memory, overload protection, battery-saving auto-off, and beep-tone functions
- Parts counting PCS
- Precision load cell technology
- Adjustable-height feet and leveling bubble indicator
- Low battery and weight stability indication
- Large size, adjustable, bright blue backlit LCD display
- 6.5" x 4.5" removable stainless steel weighing platform
- Removable protective splash guard dust cover
- Powered by six AA batteries or auto-adjustable, universal voltage 100V-240V AC adapter (included)
- Heavy-duty, long-life ABS construction with exclusive protective rubberized paint finish
- Five-year limited replacement warranty

Order #	Model	Capacity	Scale	12+	6+	1+
51-2089	PRO 6000	6000 g	0.1 g	\$135.96	\$143.96	\$159.95

**GEMORO® PLATINUM PRO 1601**

Offers significantly greater capacity than competitive scales, plus the precision, durability, and features you need.

- 1600 x 01 gram, pennyweight, troy ounce, grain, and ounce
- Parts counting
- Push-button digital calibration, tare, memory, overload protection, and auto-off functions
- Large stainless steel weighing platform
- Extra large adjustable backlit LCD display
- Durable ABS construction with exclusive protective rubberized Dura-Paint® with removable protective splash guard dust cover
- Adjustable feet and leveling bubble
- Powered by long-lasting AA alkaline batteries or by its exclusive universal voltage 100V-240V AC Adapter
- Batteries and stainless steel calibration weight included
- Five-year limited replacement warranty

Order #	Model	Capacity	Scale	12+	6+	1+
51-2077	PRO 1601	1600 g	0.1 g	\$93.46	\$98.96	\$109.95

Items shown on scale are not included.

**GEMORO® PLATINUM PRO1001V**

The Platinum PRO1001V offers the precision you want combined with the durability and features you need.

- Capacity/Readability: 1000 x 0.1 gram, troy ounce, ounce, penny weight, carat, grain, and kilogram
- Push-button digital calibration, tare, memory, overload protection, and battery-saving auto-off function
- Parts counting PCS
- Large stainless steel weighing platform
- Adjustable-height feet and leveling bubble indicator
- Low battery and weight stability indication
- Large bright blue backlit LCD display
- Powered by four long-lasting AA alkaline batteries (supplied)
- Two-year limited replacement warranty

Order #	Model	Capacity	Scale	12+	6+	1+
51-2037	1001V	1000 g	0.1 g	\$33.96	\$35.96	\$39.95

Items shown on scale are not included.



**GEMORO® PLATINUM PRO501VXP**

The Platinum PRO501VXP offers the extra precision you want combined with the durability and features you need.

- Capacity/Readability: 500 x 0.01 gram, troy ounce, ounce, pennyweight, carat, and grain
- Push-button digital calibration, tare, memory, overload protection, and battery-saving auto-off function
- Parts counting PCS
- Stainless steel weighing platform
- Adjustable-height feet and leveling bubble indicator
- Low battery and weight stability indication
- Large bright blue backlit LCD display
- Powered by four AA batteries (supplied) or universal voltage 100V-240V AC adapter (included)
- Includes two 200g calibration weights
- Black EZ-grip rubberized paint finish
- Two-year limited replacement warranty

Order #	Model	Capacity	Scale	12+	6+	1+
51-2036	501VXP	500 g	0.01 g	\$63.71	\$67.46	\$74.95

Items shown on scale are not included.

**GEMORO® PLATINUM XP500**

The XP500 from GemOro is our extra precision gold scale with amazing accuracy of 0.01 gram and the best scale for the job.

- 500 x 0.01 gram, pennyweight, troy ounce, carat, grain, and ounce
- Bright blue backlit LCD display
- Push-button digital calibration, tare, memory, low battery indicator, and battery-saving auto-off functions
- Parts counting
- Convenient four-button control panel
- Powered by two long-life AAA alkaline batteries (included)
- Includes both an extra large and low profile protective cover that also serves as a tray for holding jewelry, findings, and more
- Black EZ-grip rubberized paint finish
- Five-year limited replacement warranty

Order #	Model	Capacity	Scale	12+	6+	1+
51-2034	XP500	500 g	0.01 g	\$25.46	\$26.96	\$29.95



Items shown on scale are not included.



**BENCH SCALES**

A. Weighs in grams, ounces, troy ounces, and pennyweights. Large plate makes weighing large objects easy. Uses a 9V battery (included).

B. Weighs in grams, ounces, troy ounces, and pennyweights. Removable scale cover can be used to hold items to be weighed. Spring-loaded display and keyboard retracts into scale body. Comes with a soft cover. Uses four AAA batteries (included).

C. Weighs in grams, ounces, pennyweights, and grains. Also has parts counting. Protective cover folds out of the way so larger objects can be weighed. Comes with a weighing pan protector that can be used to hold objects to be weighed. Uses two AAA batteries (included).

**Order # 51-40600**

Item	Description	Capacity	Readability	12+	6+	1+
A	Bench Scale	1000 g	0.1 g	\$38.72	\$41.00	\$45.55
B	Scale	2000 g	0.1 g	\$29.71	\$31.46	\$34.95
C	Pocket Scale	500 g	0.1 g	\$20.40	\$21.60	\$24.00



**GEMORO® PLATINUM V600**

Features an ultra bright blue backlit display and protective cover that slides off and also serves as an ideal weighing tray.

- Pennyweight, troy ounce, and ounce
- Push-button digital calibration, tare, backlight, memory, low-battery indicator, and battery-saving auto-off functions
- Powered by long-life AAA batteries (included)
- Five-year limited manufacturer's replacement warranty.

Order #	Model	Capacity	Scale	1+
<b>51-2097</b>	V600	600 g	0.1 g	\$11.95



**GEMORO® PLATINUM® MP601**

This scale gives you the features and performance you would expect from a scale which costs twice the price.

- 600 x 0.1 gram, troy ounce, ounce, and pennyweight
- Large stainless steel weighing platform
- Bright blue backlit LCD display
- Push-button digital calibration, tare, memory, low battery indicator, and battery-saving auto-off functions
- Parts counting
- Hinged cover is removable and also serves as a convenient weighing tray
- Powered by two long-life AAA alkaline batteries (included)
- Includes stainless steel weighing platform, tray, and a protective leatherette carrying pouch
- Black EZ-grip rubberized paint finish
- Five-year limited replacement warranty

Order #	Model	Capacity	Scale	12+	6+	1+
<b>51-2098</b>	MP601	600 g	0.1 g	\$16.96	\$17.96	\$19.95

**GEMORO® PLATINUM M100XP**

- 100 x 0.01 gram, ounce, carat, grain, pennyweight, and troy ounce.
- Stainless steel weighing platform
- Bright blue backlit illuminated LCD display
- Push-button digital calibration, tare, memory, low battery indicator, and battery-saving auto-off functions
- Powered by one CR2032 lithium battery
- Includes necklace-style carrying strap, and a built-in, removable tray protective, cover for holding jewelry, findings, and more
- Durable ABS construction
- Five-year limited replacement warranty

Order #	Model	Capacity	Scale	1+
<b>51-2096</b>	M100XP	100	0.01	\$29.95



**GOLD BAR POCKET SCALE**

This mini digital pocket scale is a handy tool designed to look like a gold bar. Each includes a digital LED display and auto off feature. Lightweight and portable, these scales provide accuracy up to .01 grams and are professionally-graded for the jewelry industry.

Order #	Model	Capacity	Scale	12+	6+	1+
<b>51-4063</b>	LS-GB	50	0.01	\$8.93	\$9.45	\$10.50



**SCALE WEIGHTS**

Made from durable, polished stainless steel, these can be used to calibrate bench scales.

**Order # 51-0000**

Capacity	12+	6+	1+
50 g	\$9.10	\$9.63	\$10.70
100 g	\$9.10	\$9.63	\$10.70
200 g	\$9.10	\$9.63	\$10.70
500 g	\$9.10	\$9.63	\$10.70
1000 g	\$27.29	\$28.89	\$32.10
5000 g	\$54.57	\$57.78	\$64.20





## SCREWDRIVERS



## SCREWDRIVER SET WITH STAND

Kit Order # 59-0906

Blade Size	Color	12+	6+	1+
Set of .8, 1, 1.2, 1.4, 1.6, 1.8, 2mm	Multi	\$101.15	\$107.10	\$119.00

## SCREWDRIVER REPLACEMENT BLADES

Screw driver replacement blades for 59-0906.

Order # 59-0906

Blade Size	Color	12+	6+	1+
.08mm	Orange	\$2.51	\$2.66	\$2.95
1mm	Gray	\$2.51	\$2.66	\$2.95
1.2mm	Yellow	\$2.51	\$2.66	\$2.95
1.4mm	Black	\$2.51	\$2.66	\$2.95
1.6mm	Red	\$2.51	\$2.66	\$2.95
1.6mm	Purple	\$3.36	\$3.56	\$3.95
1.8mm	Purple	\$2.51	\$2.66	\$2.95
2mm	Green	\$2.51	\$2.66	\$2.95

.08mm 1mm 1.2mm 1.4mm 1.6mm 1.6mm 1.8mm 2mm

## EUROPEAN FIXED-BLADE SCREWDRIVER SET

European fixed-blade screwdrivers with color-coded bands to indicate sizes feature precisely ground, tempered blades with nickel handles and hex heads. Excellent quality matched with an economical price make these a winner.

Order #	Description	Blade Size	Color	12+	6+	1+
52-1037	Screwdriver Set (6-Pieces)			\$15.05	\$15.93	\$17.70

Order # 52-10380 INDIVIDUAL SCREWDRIVERS

Blade Size	Color	12+	6+	1+
0.8mm	Yellow	\$2.00	\$2.12	\$2.35
1mm	Black	\$2.00	\$2.12	\$2.35
1.2mm	Red	\$2.00	\$2.12	\$2.35
1.4mm	Gray	\$2.00	\$2.12	\$2.35
1.6mm	Violet	\$2.30	\$2.43	\$2.70
2mm	Green	\$2.30	\$2.43	\$2.70

## PRECISION-MADE SCREWDRIVER SET

Set contains nine color-coded screwdrivers on a rotating stand and replacement blades with set screws hold blade firmly. Hexagonal swivel head prevents rolling. Length is proportional to blade size and ranges from 4<sup>1</sup>/<sub>8</sub>" to 3<sup>1</sup>/<sub>4</sub>". Magnetic.

Order # 52-54000

Item	Description	12+	6+	1+
A	Screwdriver Set (9-Pieces)	\$53.34	\$56.48	\$62.75
B	Replacement Set Screw for Blade	\$1.32	\$1.40	\$1.55

Order # 52-54060 INDIVIDUAL BLADES

Blade Size	Length	Color	Per Unit	12+	6+	1+
0.6mm	.024"	Pink	3	\$1.28	\$1.35	\$1.50
0.8mm	.031"	Yellow	3	\$1.28	\$1.35	\$1.50
1mm	.039"	Black	3	\$1.28	\$1.35	\$1.50
1.2mm	.047"	Red	3	\$1.28	\$1.35	\$1.50
1.4mm	.055"	Gray	3	\$1.28	\$1.35	\$1.50
1.6mm	.063"	Purple	3	\$1.87	\$1.98	\$2.20
2mm	.078"	Green	3	\$1.87	\$1.98	\$2.20
2.5mm	.089"	Blue	3	\$2.25	\$2.39	\$2.65
3mm	.118"	Brown	3	\$2.25	\$2.39	\$2.65

Order # 52-55000 INDIVIDUAL SCREWDRIVERS

Blade Size	Color	Per Unit	12+	6+	1+
3mm	Brown	Each	\$4.68	\$4.95	\$5.50
2.5mm	Blue	Each	\$4.25	\$4.50	\$5.00
2mm	Green	Each	\$4.68	\$4.95	\$5.50
1.6mm	Purple	Each	\$4.68	\$4.95	\$5.50
1.4mm	Gray	Each	\$4.68	\$4.95	\$5.50
1.2mm	Red	Each	\$4.68	\$4.95	\$5.50
1mm	Black	Each	\$4.68	\$4.95	\$5.50
0.8mm	Yellow	Each	\$4.68	\$4.95	\$5.50
0.6mm	Lilac	Each	\$4.68	\$4.95	\$5.50



## ECONOMY SCREWDRIVER SET

Set contains nine screwdrivers in an aluminum base holder with an extra blade storage compartment. Blade sizes range from 0.6 to 2.0mm. Made in India.

Item	Order #	Description	12+	6+	1+
C	52-5470	Screwdriver Set (9-Pieces)	\$12.62	\$13.37	\$14.85

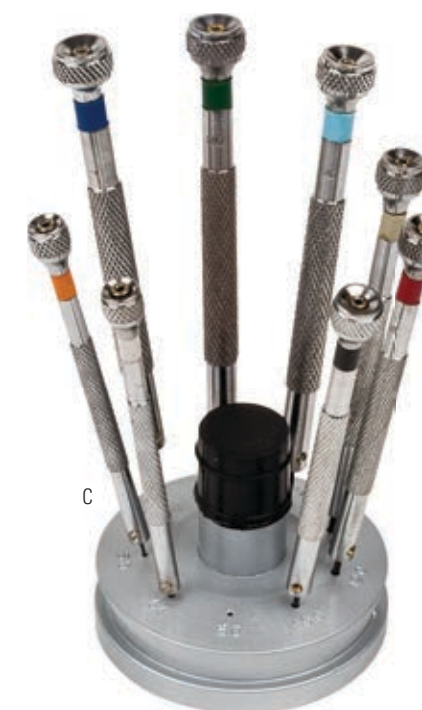



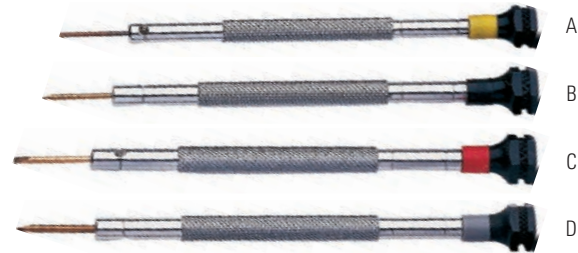

**NON-MAGNETIC SCREWDRIVERS**

Precision European screwdrivers are made with hexagonal swivel heads, which prevent rolling. Handles are knurled to allow a firm grip. Each screwdriver has a color-identifier band to allow easy selection. Blades are held in place with set screws. Flat head only.

Order # 52-09020

Item	Blade Size	Color	12+	6+	1+
A	0.8mm	Yellow	\$4.68	\$4.95	\$5.50
B	1mm	Black	\$4.68	\$4.95	\$5.50
C	1.2mm	Red	\$4.68	\$4.95	\$5.50
D	1.4mm	Gray	\$4.68	\$4.95	\$5.50

Order # 52-09060 REPLACEMENT BLADES

Blade Size	Length	12+	6+	1+
0.6mm	.024"	\$0.77	\$0.81	\$0.90
0.8mm	.031"	\$0.77	\$0.81	\$0.90
1mm	.035"	\$0.77	\$0.81	\$0.90
1.5mm	.047"	\$0.77	\$0.81	\$0.90
1.4mm	.055"	\$0.77	\$0.81	\$0.90



**PHILLIPS SCREWDRIVER SET**

Set contains four Phillips Screwdrivers in a plastic wallet: 1.5mm, 2mm, 2.5mm, and 3mm. They are chromium plated, feature a color ring, and are made with hardened steel blades. Made in France.

Item	Order #	Description	12+	6+	1+
E	52-1062	Screwdriver Set of 4	\$15.26	\$16.16	\$17.95



**SCREWDRIVER SET IN POUCH**

Set contains six screwdrivers in a pouch. This popular series of screwdrivers features color-coded hex heads and reversible blades. Blades are tempered and finely ground to exact specifications. Made in France.

Item	Order #	Description	Blade Size	Color	12+	6+	1+
F	52-1045	Screwdriver Set (6-Pieces)			\$20.36	\$21.56	\$23.95
G	52-1046	Replacement Blade Set, 3 sizes each (18-Pieces)			\$9.01	\$9.54	\$10.60

**INDIVIDUAL BLADES**

52-1060	0.6mm	Blue	\$1.83	\$1.94	\$2.15
52-1059	0.7mm	Silver	\$1.83	\$1.94	\$2.15
52-1058	0.8mm	Red	\$1.83	\$1.94	\$2.15
52-1057	1.0mm	Brown	\$1.83	\$1.94	\$2.15
52-1056	1.2mm	Green	\$1.83	\$1.94	\$2.15
52-1055	1.3mm	Black	\$1.83	\$1.94	\$2.15
52-1054	1.5mm	Orange	\$1.83	\$1.94	\$2.15



**REVERSIBLE SCREWDRIVER SET**

Made with tempered steel, this set of seven reversible screwdriver blades consists of .5mm, .6mm, .8mm, 1.2mm, 1.3mm, 1.5mm all in a plastic wallet. Made in France

Item	Order #	Description	12+	6+	1+
H	52-1063	Screwdriver Set of 7	\$25.46	\$26.96	\$29.95

**MINI SCREWDRIVER KIT**

Our value-engineered screwdriver set features three straight blades and three Phillips screwdrivers - all in small sizes.

Set includes one each of the following:

- Phillips: 1.4mm, 1.6mm, and 2mm.
- Flathead: 1.2mm, 1.4mm, and 1.6mm.

This may be the handiest set available today for small jobs.

Order #	Description	12+	6+	1+
52-1065	Screwdriver Set (6-Pieces)	\$5.61	\$5.94	\$6.60



**COLOR-CODED HEXHEAD SCREWDRIVER SET**

A popular series of screwdrivers features color-coded hex heads, reversible blades, and nickel-plating to prevent rusting. Blades are tempered and finely ground to exact specifications. Made in France.

Order #	Description	1+
52-1025	Screwdriver Set (7-Pieces)	\$46.95

Order # 52-10260 REPLACEMENT BLADES

Blade Size	Length	No	Per Unit	12+	6+	1+
1.5mm	.050"	3	12	\$11.22	\$11.88	\$13.20
1.28mm	.050"	4	12	\$11.22	\$11.88	\$13.20
1.2mm	.047"	5	12	\$11.22	\$11.88	\$13.20
1mm	.039"	6	12	\$11.22	\$11.88	\$13.20
0.8mm	.031"	7	12	\$11.22	\$11.88	\$13.20
0.7mm	.027"	8	12	\$11.22	\$11.88	\$13.20
0.6mm	.024"	9	12	\$11.22	\$11.88	\$13.20

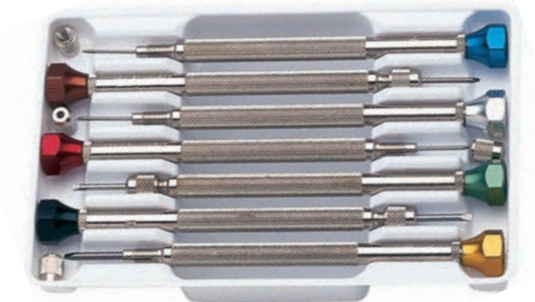

**COMBO SCREWDRIVER SET**

Economical screwdrivers feature steel blade set firmly in metal handles. Hexagon swivel head prevents rolling on bench. Includes 1.8mm, 1.5mm, 1.2mm, 1.0mm, 0.8mm, 0.7mm, and 0.6mm.

Order # 52-51400

Item	Description	12+	6+	1+
A	Screwdriver Set (7-Pieces)	\$35.57	\$37.67	\$41.85
B	Screwdriver Set (6-Pieces)	\$2.81	\$2.97	\$3.30



**PHILLIPS SCREWDRIVER SET**

This set of three Phillips fixed blade screwdrivers feature hex heads, knurled nickel-plated brass handles, and tempered steel blades.

Order #	Description	12+	6+	1+
52-1080	Screwdriver Set of 3	\$11.22	\$11.88	\$13.20





**PRECISION SCREWDRIVER**

This screwdriver features an aluminum knurled body for a sure grip and hex-swivel head that won't roll. Comes with four reversible blades.

Order #	Description	12+	6+	1+
<b>52-1034</b>	Phillips and Flat Screwdriver Set	\$7.48	\$7.92	\$8.80

**16-PIECE SCREWDRIVER AND TOOL SET**

Includes:

- 4 Phillips head screwdrivers
- 6 Flat head screwdrivers (1.0mm, 1.4mm, 2.0mm, 2.4mm, 3.0mm, and 3.8mm)
- Hex head tools (1.5mm, 2.0mm, and 2.5mm)
- 3 Nut drivers (3.0mm, 4.0mm, and 5.0mm)

Order #	Description	12+	6+	1+
<b>52-5450</b>	Screwdriver Set (16-Pieces)	\$5.36	\$5.67	\$6.30

**MASCOT SCREWDRIVER SET**

This handsome set consists of six ergonomically shaped, lightweight screwdrivers molded in texturized plastic. The screwdriver shafts are molybdenum steel, hardened and chrome plated for strength and torque. Set includes one each of the following 50mm screwdrivers:

Phillips: .90mm and 1mm.  
Flathead: 1.5mm, 2mm, 2.4mm, and 3mm.

Order #	Description	12+	6+	1+
<b>52-1070</b>	Screwdriver Set (6-Pieces)	\$11.05	\$11.70	\$13.00

**COMBO SCREWDRIVER KIT**

Set includes four straight blade screwdrivers (1.4mm, 2mm, 2.4mm, 3mm) along with 3mm and 3.5mm Phillips screwdrivers. All have hexagonal swivel heads. Packed in a convenient, hard plastic box

Order #	Description	12+	6+	1+
<b>52-1066</b>	Screwdriver Set (6-Pieces)	\$2.81	\$2.97	\$3.30

**POCKET SCREWDRIVER SET**

Designed for convenience and versatility, this pen-size, aluminum holder features a nicely finished anodized barrel and pocket clip with a built-in chuck made of steel and pressed into the barrel to firmly hold screwdriver blades and prevent turning. The screwdriver blades are made of heat treated alloy steel for strength and durability and may be stored inside the barrel. Length 3¾". Barrel diameter ⅜". A quality, U.S.-made product.

**Order # 52-10350**

Description	12+	6+	1+
Screwdriver Set (5-Pieces)	\$17.17	\$18.18	\$20.20
Replacement Blades (5-Pieces)	\$9.27	\$9.81	\$10.90

**SCREWDRIVER SHARPENER**

Spring action holds screwdriver firmly in place as tool is rolled back and forth on a sharpening stone. Steel wheels are carefully set into the body to provide even action when wheeling over stone.

Order #	Description	Width	12+	6+	1+
<b>52-1011</b>	Screwdriver Sharpener	1⅞"	\$9.73	\$10.31	\$11.45

**HARDWOOD SCREWDRIVER STAND**

Polished hardwood stand for screwdrivers and wax carvers contain carborundum stone built into the base for sharpening.

Order #	WxH	Depth	12+	6+	1+
<b>52-1012</b>	4"x2½"	2⅝"	\$9.05	\$9.59	\$10.65

**REPLACEMENT SCREWDRIVER BLADES**

Replacement screwdriver blades, set of eight.

Order #	Description	Blade Size	12+	6+	1+
<b>52-1061</b>	Replacement Blade Set	0.5-2.0mm	\$9.18	\$9.72	\$10.80





# SOLDERING SUPPLIES AND TORCHES



## Rofin Laser Welders

Back in 1992, Rofin pioneered manual laser welding. Now, after more than 25 years of market leadership, they have rethought every single detail of this successful technology. The Performance redefines the state-of-the-art of manual laser welding featuring many application-driven innovations and numerous technical refinements in an entirely newly designed housing.

The Performance is clever – it takes advantage of welding intermissions for workpiece handling. The new SPEEDmode™ increases the maximum pulse frequency significantly and uses work breaks for reloading. During longer intermissions the system switches to the energy saving ECOMode™.

The BURSTmode™ and the Pulse Ramping simplify welding tasks carried out by less experienced workers or jobs asking for high concentration, like welding of delicate medical devices. They offer a new level of control and sensitiveness, especially when combined with the new dynamic foot switch.

Rofin took a close look at how users were using their lasers and entirely redesigned the working chamber and access to it. The new open chamber design provides wide and completely free access to a spacious working area while maintaining laser safety. A unique Rocker Arm Rest provides increased operator ergonomics comfort.

The high-contrast color touch screen offers menu-driven access to all laser functions. Comfortable memory functions with various presets and a graphic shape editor make laser set up a breeze. And finally, the flat top face offers plenty of space for placing workpieces, tools or certainly coffee cups.

The Performance can go up to 150W output power and 100hz pulse frequency significantly increasing welding speed. System self-diagnostics indicate regular maintenance tasks, like air filter, water filter and flashlamp replacement.

Manual laser welding systems are frequently used as work-horses in rough work shop environments. The new cooling unit is designed for a 100% duty cycle even at high ambient temperature. The embedded control unit and state-of-the-art power supply enhance long-term stability and reliability-safeguarding reliable 24/7 operation.

### STARWELD UNLIMITED XE-POWER

#### Features–

- Mobile unit with front lockable wheel
- Easy set-up, power requirement 220 VAC, single phase, 16 amp
- Patented SweetSpot™ Resonator
- Color TFT touch display
- Leica 15X power Microscope
- LED Ring Light and 2X Halogen lighting in chamber
- Integrated HEPA air filtration
- Fixed and Flexible nozzle for assist gas (argon)
- Dynamic Footswitch for variable frequency or pulse width adjustment
- Removable base plate for large parts
- Large front chamber opening with laser safe flaps
- Rocker Arm Rest provides increased operator comfort
- Self-diagnostic programming
- Weld assist systems including;
- Pulse shaping with 12 preset and five customizable shapes
- TrueView™
- BURSTmode™
- ECOMode™
- SPEEDmode™
- IPMmode™ (Intelligent Pulse management)
- PULSE RAMPING mode

#### Specifications–

- Maximum power – 150 Watts
- Pulse peak power – 8 kWatts
- Pulse energy – 100 Joules
- Pulse frequency - single pulse, 1-50 Hz (100 Hz in SPEEDmode™)
- Pulse width - 0.3 - 50 msec
- Focal diameter - 0.2 – 2.5 mm
- Electrical - 220V, 60/50Hz, 16 amp (single phase)
- Nominal power consumption – 1700 Watts
- Standby consumption – 200 Watts
- ECOMode™ - 10 Watts
- Weld chamber dimensions (WxDxH) -23.6"×12"×9"
- Welder dimensions (WxHxD) - 22.8"×48.5"×33.6"

Order #	Description	1+
14-0110	Starweld Unlimited XE-Power	\$28,900.00



### STARWELD BASIC XE-POWER

#### Features–

- Mobile unit with front lockable wheel
- Easy setup, Power requirement; 220 VAC, single phase, 16 amp
- Patented SweetSpot™ Resonator
- Color TFT touch display
- Leica 15X power Microscope
- 2X Halogen lighting in chamber
- External exhaust port
- Flexible nozzle for assist gas (argon)
- Dynamic Footswitch for variable frequency or pulse width adjustment
- Removable base plate for large parts
- Large swing open left/right doors
- Self-diagnostic programming
- Weld assist systems including;
- Pulse shaping with 12 preset and five customizable shapes
- TrueView™
- BURSTmode™
- ECOMode™
- SPEEDmode™

#### Specifications–

- Maximum power – 150 Watts
- Pulse peak power – 8 kWatts
- Pulse energy – 100 Joules
- Pulse frequency - single pulse, 1-50 Hz
- Pulse width - 0.3 - 50 msec
- Focal diameter - 0.2 – 2.5 mm
- Electrical - 220V, 60/50Hz, 13A (single phase)
- Nominal power consumption – 1700 Watts
- Standby consumption – 200 Watts
- ECOMode™ - 10 Watts
- Weld chamber dimensions (WxDxH) - 22"×12.7"×11.6"
- Welder dimensions (WxHxD) - 22.8"×48.5"×33.6"

Item	Order #	Description	1+
A	14-0110	Starweld Basic XE-Power	\$22,970.00

### STARWELD DESKTOP XE-POWER

#### Features–

- Compact and modern housing design with small footprint
- Easy set-up, automatic adjustment to power available 110 VAC / 220 VAC
- Color TFT touch display
- Leica 15X power microscope
- LED Ring Lighting in chamber
- Convenient front opening chamber access door
- External exhaust port
- Flexible nozzle for assist gas (argon)
- Self-diagnostic programming
- TRUEVIEW™ optical path alignment ensures on target focusing 100% of the time
- Weld assist systems including;
- Pulse shaping with 12 preset and five customizable shapes
- TrueView™
- ECOMode™
- SPEEDmode™

#### Specifications–

- Nominal power – 80 Watts
- Max. power with SPEEDmode™ - 120 Watts
- Pulse peak power – 8 kWatts
- Pulse energy – 100 Joules
- Pulse frequency - single pulse, 1-50 Hz
- Pulse width - 0.3 - 50 msec
- Focal diameter - 0.2 – 2.5 mm
- Electrical - 110/220V, 60/50Hz, 16/13A (single phase)
- Nominal power consumption – 1700 Watts
- Standby consumption – 200 Watts
- ECOMode™ - 10 Watts
- Weld chamber dimensions – (WxDxH) 20"×10"×8"
- Welder dimensions (WxHxD) – 20.5"×19.8"×29.6"

Item	Order #	Description	1+
B	14-0135	Starweld Desktop XE-Power	\$18,900.00



### SPECIAL ORDER REPLACEMENT PARTS

14-0117 Laser Cuffs for Laser	14-0127 Flow Plate
14-0120 Flash Lamp	14-0128 6002 Series Air Filter
14-0121 2mm Protection Glass	14-0129 Lab Jack
14-0122 Water Filter, Full Sized Laser Welders	14-0130 Empty Wire Spools
14-0123 5002 Series Air Filter	14-0132 Leica Wedge
14-0124 12V 20W Halogen Lamp	14-0136 Argon Regulator Flow Meter Kit
14-0125 Lens Paper Pack of 50	14-0138 DI Pouch for Desktop Laser





Screen Dimensions:  
9" x 11¼" x 2"  
6½ lbs



Swing Arm  
Dimensions:  
4" x 5" x 32"  
11½ lbs



### ORION PULSE 200i WELDER

The Orion 200i<sup>2</sup> (patent pending) is an evolution in micro pulse arc welding. Built on the stability of the Orion platform, the Orion 200i<sup>2</sup> takes that next leap forward by delivering the most innovative and versatile welder on the market today. The Orion 200i<sup>2</sup> is packed with features that will simplify the welding needs of any jeweler, goldsmith, or silversmith. Innovative features include the new Pico weld mode for intricate welds as small as 0.01 Joules of energy, to achieve truly microscopic weld joints; user selectable up to 200 joules of energy for large silver or platinum pieces; a large 10" touch-screen interface with one-touch access to all welding parameters; the ultimate space saving design; and three unique pulse shape wave form choices: Classic Orion (for Orion users that have come to love welds produced by the Orion 150i), Triangle (for weld smoothing), and Square (laser like welding). The Seam mode, a revolutionary breakthrough in micro pulse arc welding, allows users to mimic laser welding with weld speeds up to 30 welds/sec. Keeping in the Orion tradition of excellent customer service, training, and support, we have added on-screen resources, which include video tutorials and a detailed product user manual. The patent pending Orion 200i<sup>2</sup> gives you the precision and speed of laser with the versatility, power, and ease of a pulse arc welder.

#### Features

- New 10" touch-screen display
- New Pico mode for extremely small and precise welds
- Three Pulse Waveforms include Classic, Triangle, Square
- Seam mode welds up to 30 welds/second
- High-frequency agitation includes negative agitation
- Internal weld monitoring provides weld consistency and automatically optimize weld parameters
- Advanced waveform shaping options
- Adaptive Weld Ignition extends electrode tip life
- Intelligent Welding and MyWeld software
- Updatable software via USB port
- Pulse arc and resistance welding technology in one machine
- 5X-10X Microscope with built-in shutter for superior

Order #	Description	1+
14-0160	Orion 200i	\$7,900.00

### ORION PULSE 150S WELDER

The Orion 150s is a powerful addition to the Orion line of pulse-arc welding technology. Like all Orion welders, the Orion 150s features a large touch-screen interface that streamlines and simplifies the welding process, allowing users to do more and to work more efficiently. Users have many features available to them including high-frequency agitation for added penetration and weld strength, adaptive weld ignition for longer electrode life, customizable save settings for fast and easy switching between weld settings, fully updateable and upgradeable software options, and so much more. The Orion 150s continues the Orion legacy by providing the most high-tech, versatile, and affordable welding solution on the market today. The Orion 150s utilizes two different welding technologies: Pulse Arc and Tack. The Tack Mode uses resistance welding technology with up to 150 watt-seconds of energy. The Tack Mode is perfect for temporary placement or permanent fusion welding. The Pulse Arc Mode uses pulse-arc welding technology and consists of two distinct energy ranges: Micro and Ultra. The Ultra energy range uses up to 150 joules of energy for projects that require deeper penetration or a larger spot size. The Micro energy range uses up to 30 joules of energy and is perfect for smaller and more delicate pieces. The Orion 150s offers a versatile, compact, and affordable welding system in an easy-to-use package.

Order #	Description	1+
14-0143	Orion Pulse 150s Welder	\$4,900.00



### ORION 100C WELDER

This compact model was designed and developed to meet the needs of the market a smaller footprint to save bench space, easy-to-use touch-screen interface for quick access and adjustments of welding parameters, high-frequency agitation options for difficult to weld metals, and more at a low initial cost. It features two different weld modes: Pulse Arc Mode and Micro Mode. Whether an application requires high-power welding needs such, as silver, or intricate, precise welds around precious stones, it has the flexibility to weld with power and precision.

Order #	Description	1+
14-0141	Orion 100c Welder	\$4,500.00



### ORION MPULSE WELDER

With a 30ws power potential, the small and friendly Orion mPulse 30 welder can be used by almost anyone and has the power to tackle all sorts of jobs. It's perfect for those needing a welder for making quick, small welds on a light-duty cycle. The mPulse power settings range from 5.0ws to 30ws in 2.5ws increments—that's 11 different power settings. The weld spot size on the smallest setting is nearly 0.8mm, depending upon your material. The largest setting of 30ws will yield a weld spot approximately 1.5mm in diameter, again, depending upon the material you're welding. The mPulse works amazingly well with gold, silver, and many other metals used in jewelry creation and repair. It's a superior alternative to any solder application; and, measuring in at 5.5" x 5.25" x 3.625", the mPulse takes up almost no space on your bench.

Order #	Description	1+
14-0161	Orion Mpulse	\$2,074.00



### ACCESSORIES

Use with any Orion Welder.

Item	Order #	Description	Tip Diameter	1+
A	14-1628	Argon Gas Regulator		\$79.50
B	14-0145	Free Floating Microscope Swing Arm		\$1,000.00
	14-0811	Tungsten Electrode Tip	1.0mm	\$45.45
C	14-0811	Tungsten Electrode Tip Set	1.0-.5mm	\$60.60
	14-0811	Tungsten Electrode Tip	.5mm	\$45.45
D	14-0157	Microscope Light Ring		\$25.25
E	14-0812	Grinding Wheel (Pack of five)		\$15.15



Soldering Equipment and Supplies

Soldering Equipment and Supplies



Turbo Braze Welder comes complete with chemicals, extra dryer filter and needles.

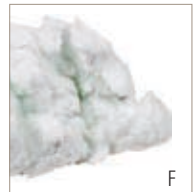

**TURBO BRAZE HYDROFLUX WELDER**

The Hydroflux hydrogen generator operates by converting distilled water into an oxygen/hydrogen fuel gas. The Hydroflux Welder creates gas on a demand basis, this means there is no potentially saved gas. A self-contained, stainless steel, gas dryer and filter prevents moisture and contaminants from mixing with flux and flame. You no longer have to waste fluxing compound because of frequent dumpings. Uses no exotic chemicals or formulas for its flux, has a readable distilled water usage gauge, and uses 30-gauge to 18-gauge disposable needles. Also has a stainless steel check valve to prevent flame blow-back. Includes chemicals, extra in-line dryer filter, eight-piece needle set, one torch, and four feet of flexible hose. Made in the USA.

Item	Order #	Description	WxDxH	1+
A	14-1509	Turbo Braze Welder	16" x 19" x 10"	\$1,275.00
B	14-1002	Potassium Hydroxide Pellets		\$68.15

**REPLACEMENT PARTS**

Order # 14-15000

Item	Description	1+
C	Torch Handle with 4 ft Hose	\$125.65
D	HydroTorch Flux	\$13.65
E	HydroTorch Electrolyte*	\$21.75
F	Cotton Dryer Filter	\$9.40
G	Filter for In-Line	\$11.90
H	Filter for Handpiece	\$11.90
J	Large O-Ring for Handpiece	\$2.55
K	Small On/Off Ring for Valve	\$2.55
L	Gasket	\$29.10
M	Tubing	\$4.60
N	Set of 9 Tips for Hydro Torch	\$5.05
P	Plastic Hose	\$6.70

\* HydroTorch Electrolyte is hazardous and ships UPS Ground only.

**TORCH FUEL INFORMATION**

**Natural Gas**

A common composition for natural gas as supplied to the consumer contains 93 parts methane, five parts ethane, and two parts propane. It is available in both liquefied and gaseous form. This fuel type is considered the most practical fuel for use in making jewelry. When supplied in its liquefied form, it is the least expensive fuel gas traditionally used by jewelers, due in part to its relatively slow burn rate (when compared to hydrogen). When using this gas type in its liquefied form, a regulator is required. A pressure setting of 6-8 PSI is adequate for all jewelry torch work. When supplied in its gaseous form by most utility companies, it is regulated down from 25-36 PSI in the large mains to about 8 PSI for general consumer use. This allows the option of direct piping (which eliminates the need for another tank), and a regulator is not required for reducing the gas pressure. When mixed with oxygen, it burns with a clean, carbon-free flame.

**Acetylene**

Acetylene is a gaseous hydrocarbon formed by joining hydrogen and carbon in an electrical arc, by the incomplete combustion of other hydrocarbons, or by other means. Although colorless, it has an unpleasant odor, similar to ether, caused by impurities. When combined with oxygen, it produces the hottest, brilliant white flame which is why it is preferred in welding. Although commonly used by many jewelers, it does not burn cleanly, and, due to the presence of unburned hydrocarbons, it is not recommended for working on platinum. Often, these unburned hydrocarbons will produce blackened deposits on jewelry items that have been melted or soldered. A regulator that is specified for use with acetylene is required and a pressure setting between 80-115 PSI is suitable for jewelry work.

**Propane (LP)**

Propane consists of propyl and methane and is supplied in a liquefied form for consumer use. It is an inexpensive fuel and tank refills are widely available. A regulator is required for lowering and stabilizing fuel pressure from the tank. The standard pressure setting for jewelry work is 6-8 PSI. Present regulators, which are sold through most RV (recreational vehicle) supply centers, are available in the pressure ranges that can be used for jewelry. When mixed with oxygen, it burns at a temperature slightly higher than natural gas and produces a clean, carbon-free flame.

*NOTE: Although these fuel types combined with compressed air are capable of producing temperatures above the melting point of platinum (see table #1), it is marginal and, therefore, not recommended for platinum work.*

CAUTION: Always wear proper eye and face protection.

**MAXIMUM TEMPERATURES FOR GAS AND COMPRESSED AIR**

FUEL	°F	TEMPERATURES °C
Natural Gas	3,565°	1,962.8°
Propane	3,494°	1,923.3°
Acetylene	3,848°	2,120°

**MAXIMUM TEMPERATURES FOR GAS AND OXYGEN**

FUEL	°F	TEMPERATURES °C
Natural Gas	5,120°	2,826.7°
Propane	5,252°	2,900°
Acetylene	5,080°	2,804.4°

**EYE PROTECTION**

Most soldering, and all welding operations on platinum jewelry, involve temperatures in excess of 1,500°C (2,732°F) at the joint face, and between 2,000°C (3,632°F) and 2,800°C (5,072°F) in the heat source. The white radiation at these temperatures is intense and is hazardous to the unprotected eye. Even a short exposure is certain to leave an after-image on the retina that will persist for several minutes and distort both positioning and color judgement. Longer exposures will produce "arc-eye" or even permanent damage to the retina. Choosing a correct filter system requires a reasonable compromise between filtering out all possible dangerous radiation and leaving enough intensity and color to enable the operator to judge position, temperature, and the condition of the piece of the jewelry being heated. Platinum sections are likely to be lightweight, but they are melted at even higher temperatures than steel. Grade 5/GW (Shade 5, gas welding) filters can be used for short work periods when soldering platinum alloys, but choose at least grade 6/GW when using the highest temperature platinum

solders for longer periods. BS679 9EW, or its international equivalent (Shade 9, electric welding), to 11EW filter glasses, should be used for long welding exposures.

Although perhaps less dangerous to the eye itself, the infrared component of high temperature flames also needs to be guarded against. While an occasional short exposure to the skin may not be harmful in itself (Personal discomfort usually quickly reminds the occasional operator that welding and soldering heat sources radiate heat very directly), repeated or prolonged exposure is dangerous. The skin should be covered, or the head and shoulder area screened, not just the eyes.

*Warning: Never try using even the densest sunglasses. At the ultraviolet end of the spectrum, they may offer some protection against general sunlight but not against a sharp concentrated image of an arc or oxy-gas flame.*





A. L/45

- Gas Production: 45 Lt/hour
- Consumption of Demineralized Water: 22cc/h
- Consumption of Alcohol: 9cc/hour
- Capacity of Alcohol container: 153cc
- Max Power: Watt 280 (115V)
- Electrolyte Quantity: 0.5 Lt
- Overall Dimensions: 28.5"W x 23"D x 29H
- Weight: 14Kg

**HYDROGEN AND OXYGEN GENERATORS**

Soldering with the power generated by this hydrogen torch system, is a terrific alternative to using pressurized fuel and oxygen tanks in your shop! This system is extremely very safe, easy to use, easy to light with a push-pull shut off mechanism. Visual controls keep you aware of the, solution levels and power levels, and allow you to set the power you need for any given soldering task. It even offers you a space-conscious footprint, taking up a minimum of precious shop space. The system produces energy by using electricity and by utilizing hydrogen and oxygen atoms from an electrolyte solution, creating a safer, cleaner and more economical hydrogen/oxygen fuel. (Consequently, with the added benefit, of a Clean Brazing Surface, No CO2 emissions, No Oxidation, a Precise Micro Flame, and a Long-Life lasting FLUX). The fuel gas produced by this catalytic reaction, is highly effective for brazing, welding, soldering, casting and other delicate repairs in the jewelry industry. The system requires very little maintenance and what maintenance is needed, is extremely easy to understand and implement, with the assistance of Video tutorials. The ET Hydrogen Micro Flame generators, are State of the Art, High Quality equipment, designed to specifically solve the users needs.

Order # 14-1523

Item	Description	1+
A	L/45	\$1,285.00
B	L/80	\$1,710.00
C	L/160	\$2,975.00



B. L/80

- Gas Production: 80 Lt/hour
- Consumption of Demineralized Water: 41cc/h
- Consumption of Alcohol: 15cc/hour
- Capacity of Alcohol Container: 225cc
- Max Power: Watt 590 (115V)
- Electrolyte Quantity: 1 Lt
- Overall Dimensions: 38.5"W x 28.5"D x 36"H
- Weight: 25 Kg



C. L/160

- Gas Production: 160 Lt/hour
- Consumption of Demineralized Water: 82cc/h
- Consumption of Alcohol: 30cc/hour
- Capacity of Alcohol container: 282cc
- Max Power: Watt 950 (115V)
- Electrolyte Quantity: 3 Lt
- Overall Dimensions: 46.5"W x 33.5"D x 41.5"H
- Weight: 45 Kg

**READY-OX OXYGEN GENERATOR TORCH SYSTEM**

"The Ready-Ox System is capable of performing most any jewelry or dental soldering, brazing or heating operation with just a standard electrical wall outlet and inexpensive, clean burning propane fuel from a disposable 14 or 16-ounce tank available at most any hardware store. The torch produces a sharp 5400° F flame for pinpoint accuracy and control. The oxygen generator will provide hundreds of hours of trouble free service. Inexpensive, disposable propane tanks are capable of providing over 20 hours of service. Never again worry about running out of oxygen or the hassle of refilling your tanks. Never worry about safety issues, insurance restrictions or fire code restrictions associated with high pressure tanks. This system may be used in your home or business and is excellent for on-site repairs especially in malls where pressurized gas cylinders are not allowed. It is easy to set up and easy to use. Simply plug it in, turn on the gas, adjust the flow, and light the torch. The Ready-Ox System includes the oxygen generator, a Genuine Smith LITTLE TORCH® with eight-foot hoses, five-tips (sizes 3 through 7), regulator for disposable propane tank, propane tank bracket, spark lighter, reverse flow safety check valves, and step-by-step setup and operation instructions.

**Benefits**

- No fire code restrictions
- Safe to use indoors
- Never run out of oxygen
- Never have to travel again to a welding gas supplier for oxygen
- Never worry about high pressure oxygen tank safety issues
- Never lug around another heavy oxygen tank
- Easy to set up and use
- Eliminate the need for an expensive high pressure oxygen regulator
- Designed to provide hundreds of hours of worry-free service
- Generator plugs into any 115V home electrical service
- Capable of running two LITTLE TORCH®es

Item	Order #	Description	1+
A	54-4581	Torch System	\$795.00



The Ready-Ox System includes the oxygen generator, a Genuine Smith Little Torch with eight foot hoses 5-tips (sizes 3 through 7), regulator for disposable propane tank bracket, spark lighter, reverse flow safety check valves and step-by-step set-up and operation instructions. These units are refurbished.

**TORCH BOOSTER**

The TB-30 Torch Booster replaces acetylene, propane, and other fuel gas cylinders to provide a steady supply of 25 psi natural gas directly from your standard utility gas line. Connect your torch booster to a single torch or shop manifold. Once started torch boosters supply all the gas you need all day without further operator attention. Just turn it off at the end of the day. The TB-30 Torch Booster supplies 30cf/hour and is the right choice for jewelry casting and manufacturers with up to five bench jewelers.

- Dimensions: 12" W x 12" H x 16" D
- Operates on 110V 60Hz 15 amp power
- Use 3/4" steel pipe to supply <1 psi natural gas to torch booster
- Regulator, flashback arrestor, and flexible five-foot hose and shut-off valve are included

Order # 54-45670

Item	Description	1+
B	G-TEC TB-30 Natural Gas Pressure Booster Kit	\$2,383.41
C	Regulator for G-TEC Pressure Booster	\$203.42
D	Regulator Mount Flashback Arrestor Pair	\$75.75
E	Maintenance Kit for Gas Booster	\$193.54



Torch and hose not included





**QUATRO SOLDERPURE**

Eliminate solder smoke and fumes at the source before they migrate through the room. Three-step filtering process effectively removes smoke and fumes from soldering, wax work, solvent vapors, and rhodium plating. Two-year factory warranty.

- Extremely quiet (52 dba)
- Casters allow mobility
- 99.9% filter efficiency
- Brushless motor, no motor maintenance
- Maintenance-friendly design, filters accessed in seconds

**Specifications**

Dimensions: 12<sup>3</sup>/<sub>4</sub>" W x 15<sup>3</sup>/<sub>4</sub>" D x 20" H  
 Weight: Operating 48 lbs.  
 Voltage: 120/1/60 (1 amp)



Order # 47-40890

Item	Description	1+
A	SolderPure Soldering	\$1,195.00
	SolderPure Rhodium-Plating	\$1,295.00

**ACCESSORIES**

Order # 47-40570

Item	Description	12+	6+	1+
B	Odor Cartridge Filter	\$127.93	\$135.45	\$150.50
C	HEPA Filter	\$127.97	\$133.54	\$139.10
D	Odor Filter F1 Rhodium Plating	\$150.24	\$159.08	\$176.75
E	Fume Extraction Flex Arm with Cone	\$81.56	\$86.36	\$95.95
F	8 SolderPure Hose	\$23.16	\$24.53	\$27.25
G	Bracket Holder	\$38.63	\$40.91	\$45.45
	Filter Pads Pk 6	-	-	\$30.30

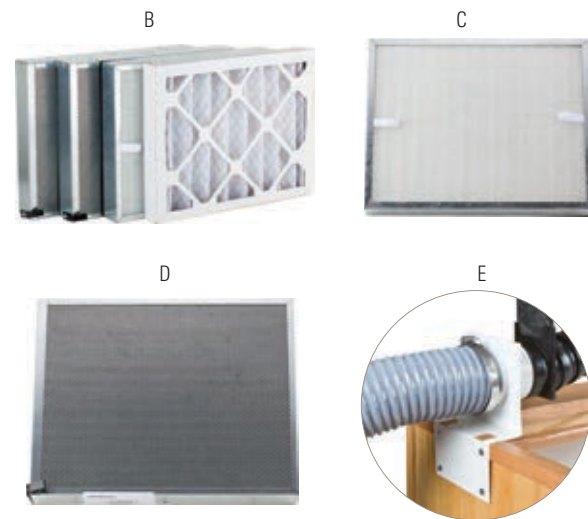

**ELECTRIC SOLDERING MACHINE**

Compact and efficient machine for soldering rings, jewelry, and eyeglass frames. The heat range is acceptable for soldering very light to heavy items, and produced electronically, without flame, by touching a carbon electrode to the work to be soldered. The current passing through the carbon will heat the object in a matter of seconds. Heat control is achieved by turning the selector knob. Carbons are copper plated to ensure good contact.

**Includes:**

Foot control, three large carbons, two small carbons, contact rod, clamps, carbon stand, and instructions. 110 volts/15 amps, maximum 1,000 watts.

Order #	Description	1+
54-0500	Soldering Machine	\$429.00

**REDI-PRONG® VACUUM APPLICATION SYSTEM**

Once jewelers use Redi-Prongs® they never go back to conventional methods for retipping prongs. This is what makes the vacuum system such an effective tool. It increases productivity. You can pay for the system with just a few retipping jobs. Can be used with torch or laser welder applications. Includes: one high power vacuum unit, one vacuum application handpiece, two niobium fire tools, three stainless applicator tips, two easy application dispensers, and 250 Redi-Prongs.

Item	Order #	Description	1+
A	57-7770	Vacuum Application System	\$295.00
B	54-1115	Soldering Pad	\$50.25
	54-1117	Niobium Fire Tools	\$4.90
	54-1118	Applicator Tips	\$4.90
	54-1119	Parts TMY	\$6.10
	54-1122	Prong Dispenser	\$149.40



**REDI-PRONGS KIT**

Item	Order #	Description	1+
C	2305	Available in 14K yellow or white Each vial contains 100 caps	\$265.98
D	21461	Each vial contains 25 caps	\$165.00
E	23406	Each vial contains 25 caps	\$244.20
F	23384	Available in 14K yellow or white Each vial contains 100 caps	\$135.21
G	21459	Available in 14K yellow or white Each vial contains 25 caps	\$380.40
H	2306	Available in 14K yellow or white Each vial contains 50 caps	\$164.85
J	21460	Available in 14K yellow or white Each vial contains 25 caps	\$113.85
K	2770	Available in 14K yellow or white Each vial contains 1 bar	\$123.36



**SOLDERING KIT**

These soldering kits have the essentials tools you need to get started. With these kits you can begin to create or repair all types of jewelry. For a entire list of kit components, visit stuller.com.

Order # 14-00080

Item	Description	1+
L	Deluxe Kit	\$529.00
M	Basic Kit	\$395.00







**LITTLE TORCH® CADDY KITS**

Includes torch, eight-foot covered hoses, preset propane regulator, oxygen regulator, oxygen cylinder, caddy carrier, check valve, and complete instruction manual. The 14.1 disposable LP tank provides up to 12 hours of running time with a #5 tip. Also works with 14.1 disposable MAPP® tank.

Order # 14-50100

Item	Description	Tip #	1+
A	Propane Caddy	#3-7	\$499.00
B	Acetylene	#3-7	\$575.00
C	Propane/Oxygen	#3-7	\$640.00

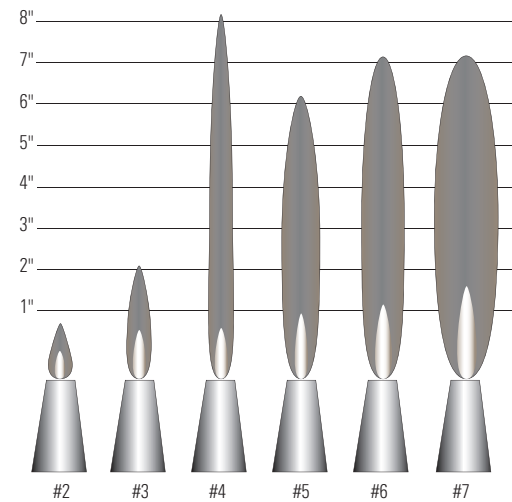

**LITTLE TORCH® KIT**

Includes torch, six-foot hose, curved tips, and instructions. Includes five tips in each kit. Packaged in display box. Hoses fit any standard regulator and can be used with any fuel, gas, or oxygen. B (3/16") fitting.

Order #	Description	1+
14-0021	Torch kit for Propane/Natural Gas	\$135.00
14-0025	Red Replacement Valve	\$28.25
14-0025	Green Replacement Valve	\$28.25



**LITTLE TORCH® KIT WITH REGULATORS**

Includes torch, eight-foot hose, curved tips, and instructions. Includes five tips in each kit. Packaged in display box. Hoses fit any standard regulator and can be used with any fuel, gas, or oxygen.

Order # 14-00220

Item	Description	1+
D	Acetylene/Oxygen Kit	\$349.00
E	Propane/Oxygen Kit	\$349.00

GENTEC has been selling torches and welding accessories worldwide for over 60 years. The "Small Torch" regulators and other accessories are high quality, manufactured to world standards, and offer great value. Braze and solder material from the tiniest up to 1/8" thick steel. Easy manipulation in very tight spaces. Provides stable and precise concentrated feather flame adapter included. All components carry a limited two-year warranty from the factory.

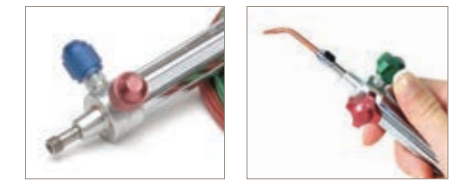

**GENTEC SMALL TORCH BASIC KIT**

Each basic kit contains the Small Torch handle, five tips, and 12-foot oxygen and fuel hoses with "B" fittings (3/16") and "A" (3/8") adapter.

Order #	Description	Tip #	12+	6+	1+
14-0758	For Oxygen/Propane	#3-7	\$110.46	\$116.96	\$129.95



**GENTEC SMALL TORCH OXYGEN/PROPANE KIT**

Convenient portable kit for use with disposable tanks comes complete with torch handle, #4 tip, six-foot hoses, and preset regulators for propane and oxygen. Wire tank holder included.

Order #	Description	12+	6+	1+
14-0756	For Oxy/Propane Disposable Tanks	\$170.00	\$180.00	\$200.00



**GENTEC SMALL TORCH KIT WITH REGULATORS**

Contains The Small Torch handle, five tips, 12-foot oxygen and fuel hoses with "B" fittings (3/16"), fitting adapter "A" (3/8"), and oxygen and acetylene or propane regulators. Precision machined brass regulators feature a compact rear entry design. Chrome-plated housing caps with plastic adjustment knob for smooth, easy-touch pressure setting.

Order #	Description	Tip #	12+	6+	1+
14-0760	For Oxy/Propane	#3-7	\$250.75	\$265.50	\$295.00
14-0759	For Oxy/Acetylene	#2-6	\$250.75	\$265.50	\$295.00



**THE SMALL TORCH BASIC KIT**

Each basic kit contains The Small Torch handle five tips and 12 oxygen and fuel hoses with "B" fittings 3/16" and "A" fittings 3/8" adapter.

Order #	Description	Tip #	12+	6+	1+
14-0757	Small Torch Basic Kit	#2-6	\$110.42	\$116.91	\$129.90







**PLATINUM MELTING TORCH KIT**

Produces a super-hot, hydrogen flame (exceeding 6,000°F.). Perfect for melting platinum as well as gold or silver. The large melting tip will melt several ounces of platinum.

Order #	Description	12+	6+	1+
14-0765	Platinum Melting Torch Kit	-	-	\$455.95
<b>REPLACEMENT PARTS</b>				
14-5060	Smith Torch Handle	\$141.65	\$149.99	\$166.65
14-0770	Oxygen Flashback Arrestor	\$36.08	\$38.21	\$42.45
14-0771	Fuel Flashback Arrestor	\$107.23	\$113.54	\$126.15
14-0772	Hydrogen Regulator	-	-	\$122.35
14-2050	Lighter (sold with one flint)	\$2.59	\$2.75	\$3.05
14-0782	Propane/Oxygen Dual Hose	\$60.05	\$63.59	\$70.65



**CASTING AND MELTING TORCH**

Complete with torch handle, type 17 #5 melting tip, and dual hose with A-B connections.

Order #	Description	1+
14-0755	Casting Torch	\$147.00



**PREST-O-LITE ACETYLENE TORCH**

Allows mixing of acetylene with air at the torch head. No other source of air is necessary. Suitable for jewelry soldering (except small work) and melting. Acetylene is stored in tanks as a liquid and only becomes a gas when the valve is opened. Outfit includes torch handle, a regulator for "B" tank, and a six-foot hose with fittings.

Order #	Description	1+
14-2350	Acetylene Torch Outfit	\$235.00



**SWISS TORCH HOSE KIT**

The Swiss Torch Hose Kit includes the, The Swiss Torch and the hose in the length of your choice. The hoses come in 6, 8, 10, and 12 feet.

Description	1+
Swiss Torch Hose -6' Kit	\$352.45
Swiss Torch Hose -8' Kit	\$355.95
Swiss Torch Hose -10' Kit	\$363.55
Swiss Torch Hose -12' Kit	\$365.95

**THE SWISS TORCH**

The most versatile, handy, lightweight, and reliable torch on the market. Use with propane and natural gas/oxygen. Not for use with acetylene. The selection of heads permit pinpoint to large flames for melting. 100% made in Switzerland.

**Order # 14-16600**

Item	Description	12+	6+	1+
A	Swiss Torch Body	\$101.15	\$107.10	\$119.00
B	Micro Head w/3 Needle Nozzles	\$133.07	\$140.90	\$156.55
C	Hoke Standard Head	\$133.07	\$140.90	\$156.55
D	Short Melting Head	\$98.73	\$104.54	\$116.15
E	Long Melting Head	\$98.73	\$104.54	\$116.15
F	Platinum Head	\$90.61	\$95.94	\$106.60

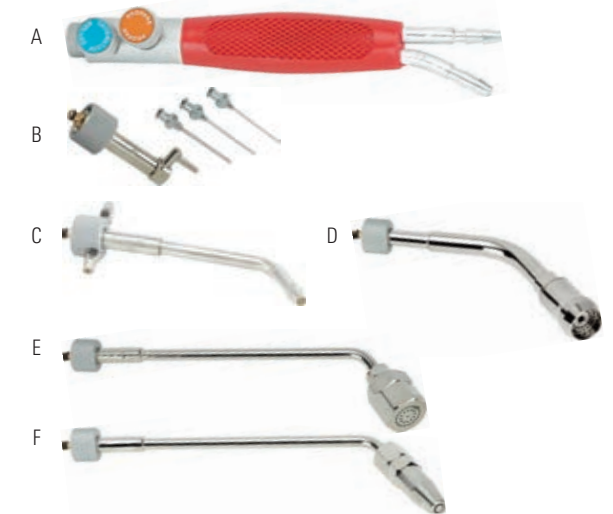

**HI-HEAT TORCH**

The mixing chamber of the Model D blowpipe is designed for use with natural, artificial, or bottled gas but not for acetylene. Produces an intense, perfectly formed flame. Use standard 1/2" hose with C-clamps.

**Order # 54-45350**

Item	Description	12+	6+	1+
G	Hi-Heat Torch	\$59.46	\$62.96	\$69.95
H	Small Gas/Air Torch	\$11.60	\$12.29	\$13.65
J	Oxygen/Gas Torch	\$6.80	\$7.20	\$8.00
K	Large Gas/Air Torch	\$11.99	\$12.69	\$14.10



**MIDGET TORCH**

Small, lightweight, and ideal for jewelry welding and brazing. Control valves are conveniently positioned and hold flame adjustment precisely. Can be used with oxygen and acetylene, hydrogen, natural gas, propane, or butane. Sold with three tips and slip-on hose connectors, for 3/16" hose. Overall length 6 3/4". Also fits hose 14-0783.

Item	Order #	Description	Length	1+
L	14-1600	Midget Torch	6 3/4"	\$245.00

**REPLACEMENT PARTS**

**Order # 14-16010**

Item	Description	Tip #	12+	6+	1+
M	Small	#1/0	\$13.98	\$14.81	\$16.45
N	Medium	#1	\$13.98	\$14.81	\$16.45
P	Large	#2	\$13.98	\$14.81	\$16.45



**OXYGEN/GAS HOKE TORCH**

Oxygen and natural gas torch sold with three tips. Fingertip control from a large flame to a very small flame. The length of the torch is nine inches, and the openings will accommodate a 1/4" hose, item 14-0782 C-clamp connections needed.

Item	Order #	Description	12+	6+	1+
Q	14-1220	Oxygen/Gas Torch	\$41.95	\$44.42	\$49.35







**SMITH CASTING TORCHES**

Smith torch handle is nickel plated. Use for casting platinum, gold, or silver. Note: Flashback arrestors recommended for use with all casting torches. UL listed with a lifetime warranty.

Order # 14-50600

Item	Description	12+	6+	1+
A	Smith Torch Handle	\$141.65	\$149.99	\$166.65
B	Oxygen/Acetylene Heating Tip	\$85.26	\$90.27	\$100.30
C	Oxygen/Propane Tip	\$54.53	\$57.74	\$64.15
D	Oxygen/Hydrogen Tip	\$51.47	\$54.50	\$60.55



**TORCH HANDLE #71**

#71 torch handle, six inches long and welds up to 1/4" steel and brazes up to six-inch copper tubing.

Order #	Description	1+
17-0756	Torch Handle	\$95.95



**WELDING TORCHES**

Top quality butane torch (14-0090) features electronic ignition (no lighter necessary) A maximum burn time of 90 minutes at 2,370 degrees Fahrenheit. Easy to adjust ensuring you have the right flame for the job. Max flame butane torch (14-0092) has a maximum output of 2,500 degrees Fahrenheit and a 40% larger tank than the 14-0090. Sturdy no-tip base.

Order # 14-00900

Item	Description	Height	12+	6+	1+
E	Butane Torch	6"	\$34.21	\$36.23	\$40.25
F	Butane Torch	7 1/4"	\$36.00	\$38.12	\$42.35

**LITTLE TORCH TIP**

Tip size #2 is for use with oxygen and acetylene or oxygen and hydrogen only. All others may be used with any fuel/gas.

Order # 14-00120

Item	Tip Shape	Tip #	12+	6+	1+
A	Curved	#2	\$21.04	\$22.28	\$24.75
B	Curved	#3	\$21.04	\$22.28	\$24.75
C	Curved	#4	\$21.04	\$22.28	\$24.75
G	Curved	#5	\$21.04	\$22.28	\$24.75
H	Curved	#6	\$21.04	\$22.28	\$24.75
J	Curved	#7	\$21.04	\$22.28	\$24.75



**LITTLE TORCH TIP**

Order # 14-10150

Item	Description	Length	12+	6+	1+
G	Acetylene/Hydrogen	6"	\$29.62	\$31.37	\$34.85
H	Propane/Oxygen	6"	\$34.64	\$36.14	\$37.65
J	Propane/Natural Gas/Oxygen	6"	\$33.49	\$35.46	\$39.40



Order # 14-10240

Item	Description	Tip #	12+	6+	1+
K	Twin Flame	#4	\$33.92	\$35.91	\$39.90
L	Twin Flame	#5	\$33.92	\$35.91	\$39.90
M	Twin Flame	#6	\$33.92	\$35.91	\$39.90



**Lease to Own**

GET THE LASER OR OTHER MAJOR TOOLS YOU NEED WITHOUT EXTENDING YOUR LINE OF BANK CREDIT

Interested in purchasing a laser or another major tool over \$4,500 and don't want to wait? Need to upgrade your shop now without stretching your bank line? Stuller has teamed with Fernwood Capital™ & Leasing to help you conserve capital and preserve credit lines by leasing to own the equipment you need.

**WHY LEASE TO OWN THROUGH STULLER?**

- You can afford to get the best Stuller tools now even if cash is tight
- An easy application process results in a quick credit decision
- Trade-up and add-on provisions help you avoid obsolescence
- Minimal down payments required to start the lease

To see your potential payment schedules, use Fernwood's convenient leasing calculator at [Stuller.com/LeaseToOwn](http://Stuller.com/LeaseToOwn).



**7-PIECE HOKE ADAPTER SET**

Expand the capabilities of your Hoke torch with this adapter set. It is ideal for soldering, welding, and even melting jobs. You will be able to solder the finest of chains to the heaviest of silver hollowware. These tips will produce a non-oxidizing flame, which means less pickling, and the piece will come out with less cleanup time. The higher the number, the smaller the hole size.

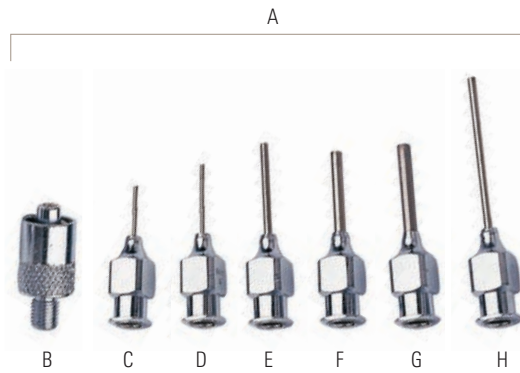

Item	Order #	Description	12+	6+	1+
A	14-0600	Adapter Set with 6 Tips	\$20.02	\$21.20	\$23.55
B	14-0601	Adapter	\$6.21	\$6.57	\$7.30

**INDIVIDUAL TIPS**

Order # 14-06020

Item	Description	Tip #	12+	6+	1+
C	Large Area Tip	#1	\$3.02	\$3.20	\$3.55
D	Soft Direct Flame Tip	#2	\$3.02	\$3.20	\$3.55
E	Strong Small Flame Short Tip	#3	\$2.59	\$2.75	\$3.05
F	Tip	#4	\$2.59	\$2.75	\$3.05
G	Mini-Micro Flame Short Tip	#5	\$2.59	\$2.75	\$3.05
H	Super Micro Flame Large Tip	#6	\$2.59	\$2.75	\$3.05

**TIPS FOR STANDARD MODEL JEWEL HOKE TORCH**

Extra tips for oxygen/artificial gas, oxygen/acetylene, or oxygen/natural gas standard model jewel hoke torches.

Order # 14-13000

Description	Flame Type	12+	6+	1+
Oxygen/Artificial Gas	Pinpoint	\$2.59	\$2.75	\$3.05
Oxygen/Artificial Gas	Pencil	\$2.59	\$2.75	\$3.05
Oxygen/Artificial Gas	Small	\$2.59	\$2.75	\$3.05
Oxygen/Artificial Gas	Large	\$2.59	\$2.75	\$3.05
Oxygen/Acetylene	Pinpoint	\$2.17	\$2.30	\$2.55
Oxygen/Acetylene	Pencil	\$2.59	\$2.75	\$3.05
Oxygen/Acetylene	Small	\$2.59	\$2.75	\$3.05
Oxygen/Acetylene	Large	\$2.59	\$2.75	\$3.05
Oxygen/Natural Gas	Pencil	\$2.59	\$2.75	\$3.05
Oxygen/Natural Gas	Small	\$2.59	\$2.75	\$3.05
Oxygen/Natural Gas	Large	\$2.59	\$2.75	\$3.05

**WELDING TORCH TIP #17**

#17 welding torch tip.

Order #	Description	1+
17-0757	Torch Tip	\$32.15

**LARGE FLAME TIP AIR/ACETYLENE**

Large flame tip for use with air/acetylene.

Order #	Description	12+	6+	1+
14-5043	Large Flame Tip	\$31.24	\$33.08	\$36.75

**MEDIUM FLAME TIP AIR/ACETYLENE**

Medium flame tip for use with air/ acetylene.

Order #	Description	12+	6+	1+
14-5042	Medium Flame Tip	\$31.24	\$33.08	\$36.75



**TI RESEARCH TORCH**

Torch tube with Tip, 27,000KJ/H

Order #	Description	1+
14-0701	Torch Tube with Tip	\$86.20



**LITTLE TORCH® HOSES AND CONNECTIONS**

Designed for the LITTLE TORCH®, the hoses are supplied with hose fittings and a connection tool. Hoses measure eight feet in length with 1/8" inside diameter. Available in single or twin hose types.

Item	Order #	Description	Type	12+	6+	1+
A	14-0524	Oxygen/Fuel Hose	Twin	\$68.64	\$72.68	\$80.75
B	14-0522	Red Fuel Gas Hose	Single	\$26.65	\$28.22	\$31.35
C	14-0523	Green Oxygen Hose	Single	\$26.65	\$28.22	\$31.35
D	14-0525	Hose Ferrule		\$8.03	\$8.51	\$9.45
E	14-0526	Crimping Tool for Hose Ferrule		\$8.03	\$8.51	\$9.45

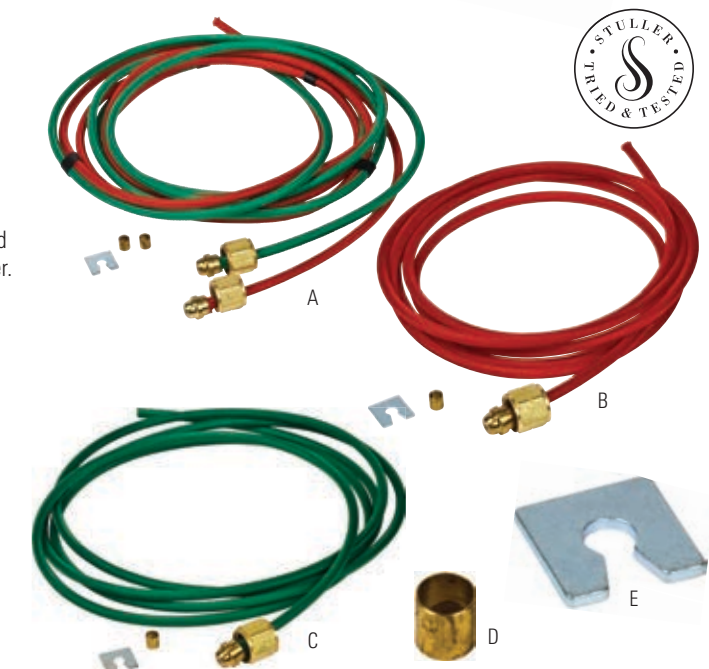

**PRIMO® FIRE RESISTANT LITTLE TORCH HOSE**

Primo® fire resistant torch hoses are designed for the LITTLE TORCH®. These hoses are 1/3 lighter weight per foot and larger in diameter. Available in lengths of 6, 8, 10 and 12 feet.

Order # 14-0527

Description	Length	ID	12+	6+	1+
PRIMO Torch Hose	6 ft	1/8"	\$34.68	\$36.72	\$40.80
PRIMO Torch Hose	8 ft	1/8"	\$39.48	\$41.81	\$46.45
PRIMO Torch Hose	10 ft	1/8"	\$44.97	\$47.61	\$52.90
PRIMO Torch Hose	12 ft	1/8"	\$49.17	\$52.07	\$57.85



**HOSE CLAMPS**

Hose Clamps used for Primo® fire resistant torch hoses.

Order # 14-0751

Description	ID	12+	6+	1+
Hose Clamp	1/8"	1.96	2.07	2.30
Hose Clamp	3/16"	2.55	2.70	3.00







**GENTEC SMALL TORCH HOSE**

Durable and flexible hoses for The Small Torch come standard with "B" fitting and include an "A" fitting adapter with each.

Order #	Description	12+	6+	1+
<b>14-0761</b>	Small Torch Replacement Hose, 12'	\$42.08	\$44.55	\$49.50



**PRIMO® FIRE RESISTANT MECO TORCH HOSE**

Primo® fire resistant torch hoses are designed for the Meco Midget Torch. These hoses are 1/3 lighter weight per foot and larger in diameter. Available in lengths of 6, 8, 10 and 12 feet and inside diameters of 1/8" and 3/16".

Description	Length	ID	12+	6+	1+
PRIMO Torch Hose	6 ft	3/16"	\$56.65	\$59.99	\$66.65
PRIMO Torch Hose	6 ft	1/8"	\$38.59	\$40.86	\$45.40
PRIMO Torch Hose	8 ft	3/16"	\$64.35	\$68.13	\$75.70
PRIMO Torch Hose	8 ft	1/8"	\$35.33	\$35.33	\$35.33
PRIMO Torch Hose	10 ft	1/8"	\$38.32	\$38.32	\$38.32
PRIMO Torch Hose	10 ft	3/16"	\$54.37	\$54.37	\$54.37
PRIMO Torch Hose	12 ft	3/16"	\$74.67	\$79.07	\$87.85
PRIMO Torch Hose	12 ft	1/8"	\$54.06	\$57.24	\$63.60

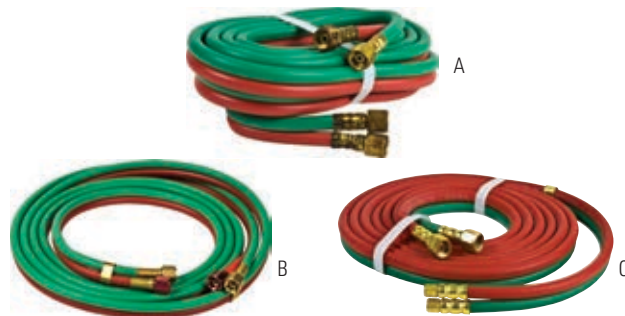

**TORCH HOSES**

Twin oxygen/fuel hoses for casting and brazing torches 3/16" diameter by 12 feet long. Twin fuel gas/oxygen hoses. R-Grade Oxygen/Acetylene Hose "B" 9/16" (14.3mm) fittings

Item	Description	12+	6+	1+
A	R-Grade Oxygen/Acetylene B Hose	\$38.17	\$40.41	\$44.90
B	R-Grade Oxygen/Acetylene A Hose	\$38.17	\$40.41	\$44.90
C	Propane/Oxygen Dual Hose	\$60.05	\$63.59	\$70.65



**GRADE T RUBBER HOSE**

Flexible Grade T twin welding hose is color coded; Green for Oxygen with right hand thread fittings and Red for LP Fuel gas with left hand thread fittings to prevent improper hose connection for your safety.

Order #	Description	1+
<b>14-0783</b>	Rubber Hose	\$37.00



**PRIMO® FIRE RESISTANT SWISS TORCH HOSE**

Primo® fire resistant torch hoses are designed for The Swiss Torch. These hoses are 1/3 lighter weight per foot and larger in diameter. Available in lengths of 6, 8, 10 and 12 feet and inside diameter 3/16".

Description	Length	12+	6+	1+
PRIMO Torch Hose	6"	\$50.62	\$53.60	\$59.55
PRIMO Torch Hose	8"	\$44.85	\$44.85	\$44.85
PRIMO Torch Hose	10"	\$48.72	\$48.72	\$48.72
PRIMO Torch Hose	12"	\$68.64	\$72.68	\$80.75

**Y CONNECTORS**

Use in multiple-torch hook-ups. With a single regulator, shut-off valve.

Item	Description	12+	6+	1+
A	Fuel Gas 3/16" LH to 3/16" - 18 LH	\$41.26	\$43.06	\$44.85
B	Oxygen 3/16" RH to 3/16" - 18 RH	\$41.26	\$43.06	\$44.85
C	Oxygen Little Torch	\$51.24	\$53.47	\$55.70
D	Fuel Little Torch	\$51.80	\$54.05	\$56.30



**RIGHT-HAND THREADED CONNECTORS FOR OXYGEN**

Used on regulators so that standard ID hose can be used.

Item	Order #	Description	ID	12+	6+	1+
E	<b>14-0777</b>	Connection for Oxygen	3/16-18"	\$5.06	\$5.36	\$5.95
F	<b>14-0778</b>	Connection for Oxygen	3/16-18"	\$5.06	\$5.36	\$5.95
G	<b>14-0779</b>	Connection for Oxygen	3/8"-24"	\$5.06	\$5.36	\$5.95

**CHECK VALVES/FLASHBACK ARRESTORS**

Stops flashback fires by preventing reverse gas flow with automatic reset between flashes. Solid brass case is durable and easy to install. Fits standard 3/16" B connections.

Item	Description	12+	6+	1+
H	For Fuel Gas Lines	\$36.08	\$38.21	\$42.45

**CHECK VALVE**

Used to help prevent dangerous reverse gas flow.

Description	OD	12+	6+	1+
For Fuel Gas Regulator	3/16 LH	\$12.58	\$13.32	\$14.80
For Oxygen Regulator	3/16 RH	\$12.58	\$13.32	\$14.80

**COUPLER**

BF-4HP 1/4" NPT female to 1/4" NPT female brass pipe thread connector.

Order #	Description	12+	6+	1+
<b>14-1781</b>	Coupler 1/4" NPT	\$5.44	\$5.76	\$6.40

**LITTLE TORCH KEY WRENCH UNIVERSAL**

Universal torch wrench.

Order #	Description	1+
<b>54-4530</b>	Torch Key Wrench	\$18.00



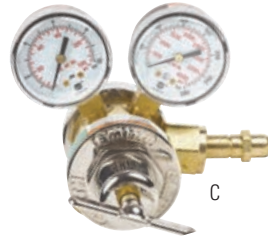
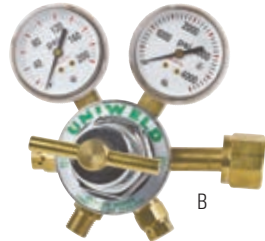
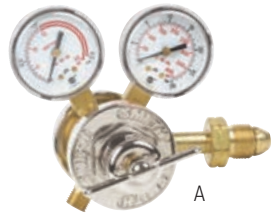

**REGULATORS**

Dual stage regulators are used where a steady delivery pressure is required over a range of decreasing cylinder inlet pressures. Delivery pressures will remain constant until inlet pressure is nearly depleted. Recommended when using more than two torches. UL listed.

Order # 14-16240

Item	Description	12+	6+	1+
A	Dual Stage Heavy Duty Acetylene Regulator	\$229.95	\$239.95	\$249.95
B	Dual Stage Oxygen Regulator	\$161.46	\$170.96	\$189.95
C	Dual Stage Heavy Duty Oxygen Regulator	-	-	\$249.95



**GENTEC REGULATORS**

Gentec regulators are manufactured using the latest state-of-the-art equipment. With chrome-plated housing caps and body machined from class "A" brass bar stock, our regulators are single stage with rear entry construction. This compact rear mounted design allows the regulators to better fit in caddy systems and stay safely out of the way. Internal safety pressure relief valve and stem type seat assembly for more reliable seating.

Order # 14-16300

Item	Description	12+	6+	1+
D	Oxygen Regulator	\$76.46	\$80.96	\$89.95
E	Propane Regulator	\$76.46	\$80.96	\$89.95
F	Acetylene Regulator	\$76.46	\$80.96	\$89.95



**SINGLE STAGE REGULATORS**

- Machined brass body, polished chrome bonnet
- Easy-to-read single scale 2 1/2" gauges
- 2" tri-layered reinforced neoprene diaphragm
- Heavy duty mechanical stem type seat and nozzle assembly
- Delrin bushing for smooth flow adjustment
- Fine mesh filter screen between inlet and seat
- Pressure relief device for low pressure gauge protection only
- Measures: 5 1/2" D x 7 1/4" W x 6" H
- Weight: 3 lbs.

Order # 14-16070

Item	Description	Connection	12+	6+	1+
G	Acetylene Regulator	"B" (LH) 9/16 - 18 (M)	\$102.00	\$108.00	\$120.00
H	Propane Regulator	"B" (LH) 9/16 - 18 (M)	\$102.00	\$108.00	\$120.00
J	Oxygen Regulator	"B" (LH) 9/16 - 18 (M)	\$102.00	\$108.00	\$120.00

**ACETYLENE REGULATOR**

Regulator for use with acetylene.

Order #	Description	12+	6+	1+
14-1627	Acetylene Regulator	\$96.26	\$101.93	\$113.25



**REGULATORS**

Single stage regulators are widely used for general purpose, gas control applications where nominal delivery pressure changes due to decreasing cylinder pressure do not significantly affect operations. Single stage regulators have greater flow capacity than dual stage regulators.

Order #	Description	12+	6+	1+
14-1622	Single Stage for Acetylene B Regulator	\$104.13	\$110.25	\$122.50



**REGULATORS**

Single stage regulators are widely used for general purpose, gas control applications where nominal delivery pressure changes due to decreasing cylinder pressure do not significantly affect operations. Single stage regulators have greater flow capacity than dual stage regulators.

Order #	Description	12+	6+	1+
14-1623	Single Stage for Acetylene LP Regulator	\$104.13	\$110.25	\$122.50



**MEDIUM-DUTY SINGLE STAGE REGULATOR, ACETYLENE**

This Miller-Smith Sure Seat™ single-stage regulator features filtered seat technology to prevent contamination. It also features a rugged forged body and corrosion-resistant, nickel-plated bonnets.

Order #	Description	1+
14-0018	Single Stage Regulator	\$142.30



**REGULATORS**

Single stage regulators are widely used for general purpose, gas control applications where nominal delivery pressure changes due to decreasing cylinder pressure do not significantly affect operations. Single stage regulators have greater flow capacity than dual stage regulators.

Order #	Description	12+	6+	1+
14-1621	Single Stage for Acetylene MC Regulator	\$104.13	\$110.25	\$122.50





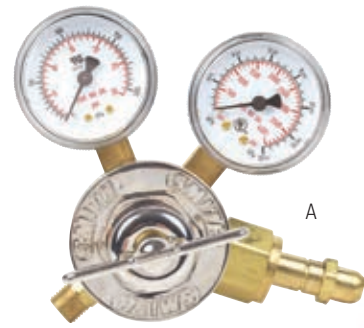

A

**REGULATORS**

Dual stage regulators are used where a steady delivery pressure is required over a range of decreasing cylinder inlet pressures. Delivery pressures will remain constant until inlet pressure is nearly depleted. Recommended when using more than two torches. UL listed.

Item	Order #	Description	12+	6+	1+
A	14-1620	Single Stage for Oxygen Regulator	\$101.96	\$107.96	\$119.95

**FLOWMETER ARGON / OXYGEN**

Regulator for use with argon/ oxygen.

Item	Order #	Description	12+	6+	1+
B	14-1640	Flowmeter	\$109.86	\$116.33	\$129.25

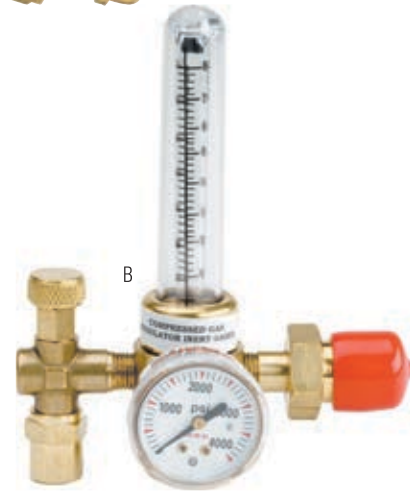

B

**FLOWMETER FOR ARGON/ HELIUM**

Flowmeter for use with argon/ helium.

Item	Order #	Description	1+
C	14-1641	Flowmeter	\$100.00



C

**REGULATOR ADAPTER**

Regulator adapter.

Item	Order #	Description	12+	6+	1+
D	14-1780	1/4" NPT Male Adapter	\$11.65	\$12.33	\$13.70



D

**WELDING TANKS**

With a sturdy no-tip base, these tanks provide standard capacities for most jewelry manufacturing. Tanks are sold empty due to shipping laws.

Item	Order #	Description	Size	12+	6+	1+
E	14-5030	Oxygen Tank	20 cubic feet	\$133.72	\$139.54	\$145.35
F	14-5034	Propane Tank	5 lbs	\$98.53	\$102.82	\$107.10



E

F

**REGULATORS FOR DISPOSABLE TANKS**

This regulator is designed to work with disposable tanks and give a controlled flow of fuel and oxygen for the Little Torch®.

Item	Order #	Description	1+
G	14-0410	Oxygen Regulator	\$50.00
H	14-0420	Gas Regulator	\$50.00



G



H

**TORCH LIGHT**

Produces spark to light gas without an open flame.

Order # 14-20500

Item	Description	12+	6+	1+
A	Lighter (sold with one flint)	\$2.59	\$2.75	\$3.05
B	Lighter (sold with five flints)	\$2.17	\$2.30	\$2.55

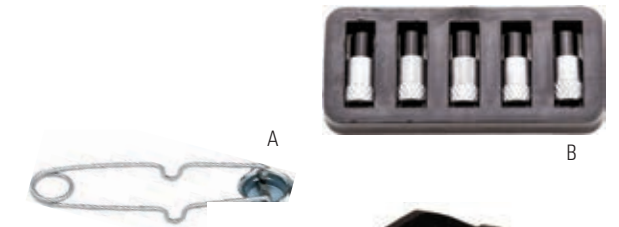

A

B

**TORCH-MATE LIGHTER**

Electric torch lighter. When the activator bar is depressed, a spark instantly lights the torch. Uses two AA batteries, not included.

Item	Order #	Description	12+	6+	1+
C	14-2040	Torch Light	\$28.56	\$30.24	\$33.60



C

**MAGNETIC TORCH HOLDER**

Magnetic torch holder keeps your torch nearby on your bench. Heavy metal base keeps holder in place. Has holes for extra tip storage.

Item	Order #	Description	12+	6+	1+
D	14-2032	Magnetic Torch Holder	\$29.33	\$31.05	\$34.50



D

E

**WEIGHTED TORCH STAND**

Allows you to rest torch while working. Rod is made of stainless steel, which ensures easy placement and removal of torch without sacrificing safety. Base is made of textured cast iron. Also provides storage space for extra tips.

Item	Order #	Description	12+	6+	1+
E	14-2030	Torch Stand	\$12.54	\$13.28	\$14.75



F

G

**UNIVERSAL TORCH HOLDER**

Mounts to bench-top for easy access. Width 1 1/2", height 3 1/2".

Item	Order #	Description	12+	6+	1+
F	14-2011	Torch Holder	\$5.36	\$5.67	\$6.30

**TORCH HOLDER**

Mounts anywhere on bench to accommodate most torches.

Item	Order #	Description	12+	6+	1+
G	14-2010	Hook-Type Torch Holder	\$2.55	\$2.70	\$3.00

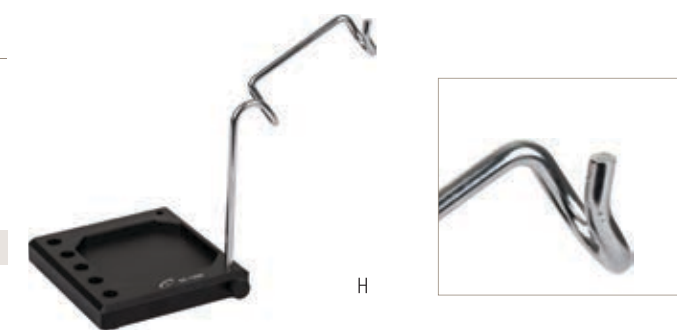

H

**DELUXE TORCH MATE STAND**

Allows you to rest torch while working. Rod is made of stainless steel, which ensures easy placement and removal of torch without sacrificing safety. Base is made of textured cast iron. Also provides storage space for extra tips.

Item	Order #	Description	12+	6+	1+
H	14-2031	Torch Mate Stand	\$27.16	\$28.76	\$31.95



Soldering Equipment and Supplies

Soldering Equipment and Supplies



**ROTATING SOLDERING BOARD WITH DOUBLE THIRD-HAND**

The 8½" soldering turntable allows you to turn your work a full 360°. The third hands are removable.

Order #	Size	12+	6+	1+
54-1202	8½" Diameter	\$81.56	\$86.36	\$95.95



**GRS® THIRD-HAND SOLDER STATIONS**

Precise soldering is easy by holding parts in the exact position needed with unequalled flexibility. These third-hands can twist, rotate, and bend in all directions. GRS soldering stations combine third-hands with durable non-asbestos soldering boards. These convenient packages help to reduce bench clutter and speed up soldering jobs. Sits on a bench or fits BenchMate® fixed mounting plate.

Order # 26-41170

Item	Description	12+	6+	1+
A	Short Double Third-Hand Solder Station	\$89.08	\$94.32	\$104.80
B	Standard Double Third-Hand Station	\$125.63	\$133.02	\$147.80



**ACCESSORIES**

Order # 26-41150

Item	Description	12+	6+	1+
C	Short Third-Hand Attachment	\$37.36	\$39.56	\$43.95
D	Standard Third-hand Attachment	\$40.12	\$42.48	\$47.20
E	Standard Third-hand on Metal Base	\$53.76	\$56.93	\$63.25

Order # 26-41180

Item	Description	W×L	12+	6+	1+
	Soldering Station	6"×6"	\$55.38	\$58.64	\$65.15
F	Soldering Station	4"×4"	\$30.86	\$32.67	\$36.30
G	Solder Board	6"×6"	\$12.97	\$13.54	\$14.10
	Solder Board	4"×4"	\$8.33	\$8.69	\$9.05

**REPLACEMENT PARTS**

Order # 26-41220

Description	12+	6+	1+
Extra Jaw	\$6.72	\$7.11	\$7.90
Tungsten Jaw	\$10.58	\$11.21	\$12.45
Replacement Spring	\$2.21	\$2.34	\$2.60

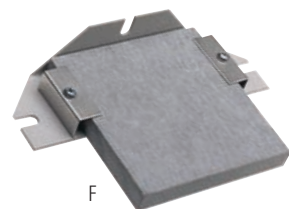
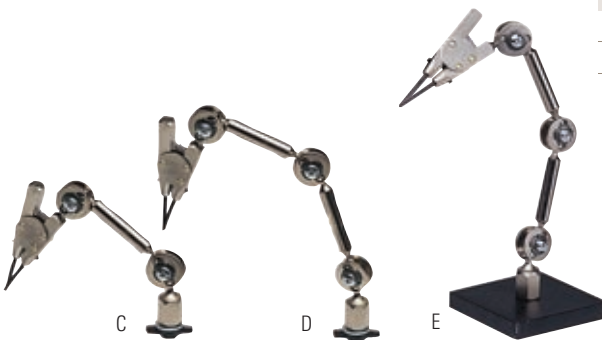

**DELUXE THIRD HAND**

Heavy metal base holds 6½" self-locking tweezers (included) and adjusts to all angles. Made in the USA. Shipping weight 1.2 lbs.

Item	Order #	Description	12+	6+	1+
A	54-4560	Deluxe Third-Hand	\$15.73	\$16.65	\$18.50
B	57-7600	Straight Soldering Tweezers	\$4.68	\$4.95	\$5.50



**SELF-LOCKING TWEEZERS**

Self-locking, soldering tweezers feature a fiber grip and heat-resistant handles

Order # 57-76000

Description	12+	6+	1+
C Straight Soldering Tweezers	\$4.68	\$4.95	\$5.50
D Curved Soldering Tweezers	\$3.53	\$3.74	\$4.15



**THIRD HAND WITH TWEEZERS AND ROUND BASE**

Cross-locking tweezers are mounted on a heavy, non-tipping, round base. Ball-joint attachments located on the base allow work to be positioned at any angle. Free both hands by positioning pieces to be joined by solder or adhesive.

Item	Order #	Description	12+	6+	1+
E	54-0801	Third Hand with Tweezers	\$12.88	\$13.64	\$15.15
F	57-7615	Blunt/Serrated Points	\$4.00	\$4.23	\$4.70

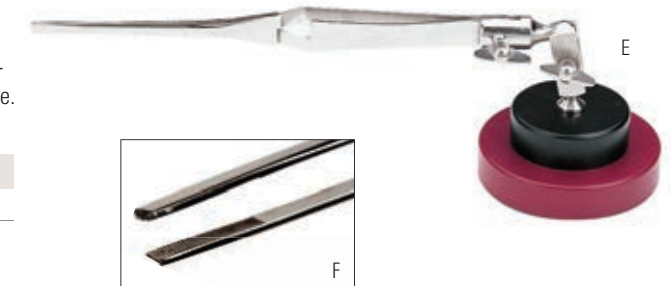

**DOUBLE CLAMP-ON STAND**

Horseshoe-base stand with two spring-loaded clips. Ball joint attachments allow work to be positioned at any angle. Frees both hands for work. Cross-locking tweezers and other accessories may be added to increase versatility.

Order #	Description	12+	6+	1+
54-0802	Double Clamp-on Stand	\$17.13	\$18.14	\$20.15



Soldering Equipment and Supplies

Soldering Equipment and Supplies



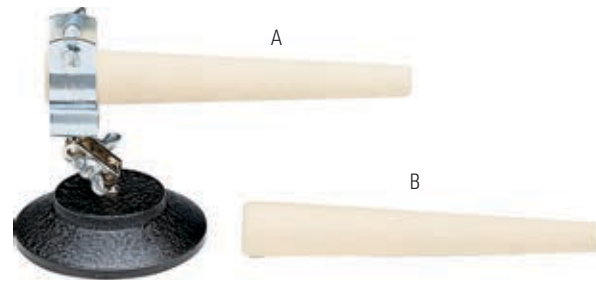

**CERAMIC RING STAND**

Six-inch tapered, heat-resistant, ceramic mandrel holds rings in place while you solder. Mounted on base with swivel to provide the exact position or angle desired. Equipped with a clamp, which releases the rod for replacement.

Order # 54-11080

Item	Description	12+	6+	1+
A	Ring Stand	\$18.91	\$20.03	\$22.25
B	Replacement Ceramic Rod	\$9.90	\$10.49	\$11.65



**CARBON RING STAND**

Six-inch tapered, carbon rod in fixed position on a heat-resistant (non-asbestos) base. Prevents collapse or movement when fitting shank sections together.

Order # 54-11120

Item	Description	12+	6+	1+
C	Ring Stand	\$23.04	\$24.39	\$27.10
D	Replacement Carbon Rod	\$9.48	\$10.04	\$11.15



**ROTATING SOLDERING PANS**

Our seven-inch soldering pans rotate 360 degrees with easy access. The heat reflecting pumice is perfect for supporting your project in any position: flat or embedded. This pan comes with an attachable third hand, custom designed to fit with our pans. Each pan includes pumice.

Order # 54-12000

Item	Description	12+	6+	1+
E	Soldering Pan	\$25.71	\$27.23	\$30.25
F	Soldering Pan with Attachable Third Hand	\$30.90	\$32.72	\$36.35



**ANNEALING PAN**

Twelve-inch diameter pan that rotates on ball bearings, providing 360 degree access. Allows positioning of work while annealing or soldering on a heat-reflecting material such as pumice. 2 1/2 lbs of lump pumice included.

Order # 54-11040

Item	Description	Weight	12+	6+	1+
G	Annealing Pan	6 lbs	\$49.98	\$52.92	\$58.80
H	Pumice	2 1/2 lbs	\$15.69	\$16.37	\$17.05



**COOL CUP**

Used to keep the stone cool while soldering. Simply fill the cup with cool water and submerge the stone and mounting while soldering. Includes special sized, negative locking tweezers, which is designed to slip on and off the post.

Order #	Description	12+	6+	1+
54-7000	Cool Cup	\$12.71	\$13.46	\$14.95



**RING HOLDER FOR SOLDERING**

Heavy, cast-iron base keeps holder and ring from moving during soldering. Prongs are adjustable for different size rings. Base diameter is three inches and total height is two inches.

Order #	Description	12+	6+	1+
54-1120	Ring Holder	\$7.57	\$8.01	\$8.90

**TRIPOD WITH MESH SCREEN**

Use to solder or heat from underneath. Works with alcohol lamp or with torch and can be placed over Bunsen® burner.

Order # 14-31200

Item	Description	Height	12+	6+	1+
A	Tripod with Mesh Screen	6 1/2"	\$12.03	\$12.74	\$14.15
B	Replacement Mesh Screen		\$3.23	\$3.42	\$3.80

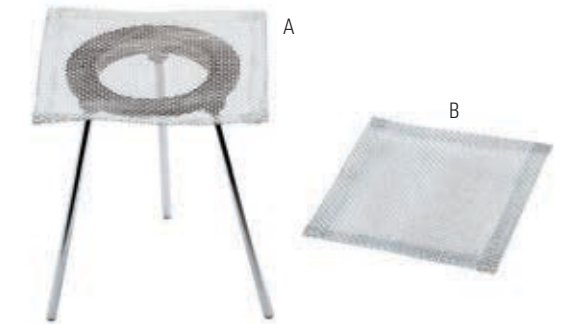

**SOLDERITE™ SOLDERING PADS**

Clean, long-lasting, asbestos-free solder pads made from reinforced calcium silicate. Excellent heat reflection and cools quickly without cracking or crumbling. The soft pads may be pinned, drilled, or shaped to hold components while soldering. Meets OSHA standards as an asbestos-free substitute.

Order # 54-18800

Item	Description	WxL	Thickness	12+	6+	1+
C	Hard	6"×6"	1/2"	\$7.74	\$8.19	\$9.10
D	Hard	6"×12"	1/2"	\$12.24	\$12.96	\$14.40
E	Hard	12"×12"	1/2"	\$20.40	\$21.60	\$24.00
F	Soft	6"×6"	3/4"	\$8.54	\$9.05	\$10.05

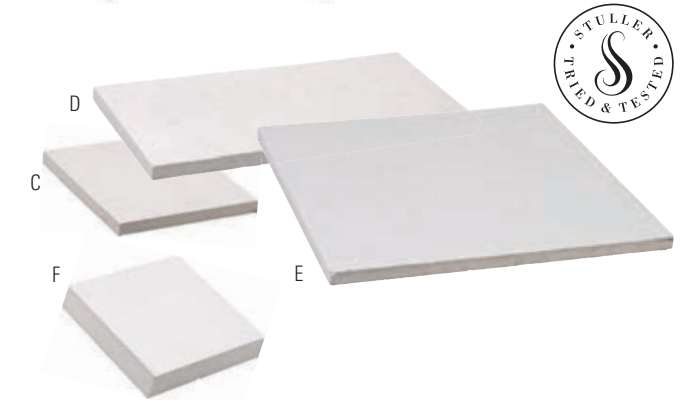

**TRANSITE-SOLDERING HARD BOARDS**

Durable non-asbestos heat reflective material. Flame resistant to protect surfaces from burning. Withstands temperatures up to 2,800 degrees

Order # 54-19000

Item	Description	WxL	12+	6+	1+
G	Transite Board	6"×6"	\$12.47	\$13.01	\$13.55
H	Transite Board	6"×12"	\$17.62	\$18.38	\$19.15
J	Transite Board	12"×12"	\$34.50	\$36.00	\$37.50

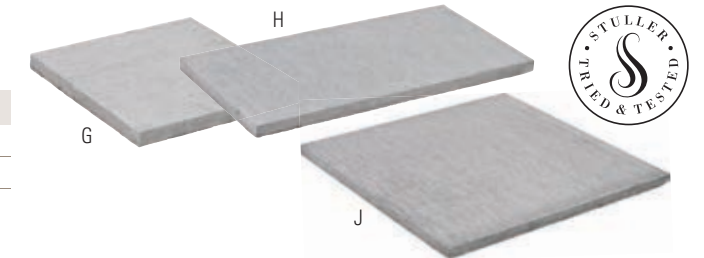

**CERAMIC SOLDERING BOARDS**

Tolerates temperatures of up to 2,000 degrees Fahrenheit. Resistant to molten metals and most chemicals and solvents. Hard surface.

Order # 54-19040

Item	Description	WxL	12+	6+	1+
K	Ceramic Board	6"×6"	\$11.99	\$12.69	\$14.10
L	Ceramic Board	6"×12"	\$17.28	\$19.44	\$21.60
M	Ceramic Board	12"×12"	\$23.74	\$24.77	\$25.80

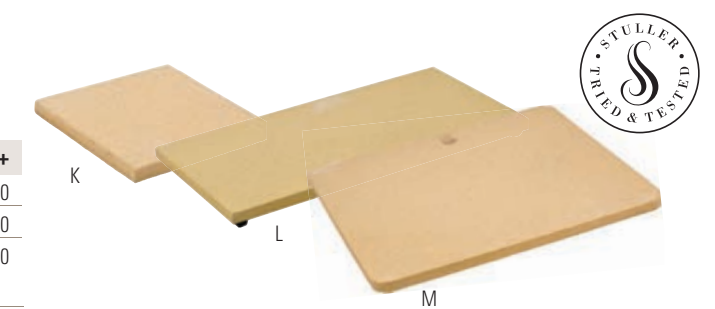

**SKAMOLEX SOLDERING BOARDS**

Skamolex soldering boards are lightweight, produce no fumes, and are asbestos-free. Like on charcoal blocks, the heat will remain concentrated on the jewelry pieces. They are non-combustible, though it looks like wood, it won't burn. Clean, unlike charcoal, and good to keep the workplace tidy. Tools, tweezers, picks, etc. can be inserted into these boards.

Order # 54-19100

Item	Description	WxL	Thickness	12+	6+	1+
N	Block	2 3/4"×5 1/2"	1 3/8"	\$3.87	\$4.10	\$4.55
P	Round Disk	4 1/2"	1/2"	\$8.67	\$9.18	\$10.20
Q	Round Disk	5 3/4"	1/2"	\$9.69	\$10.26	\$11.40

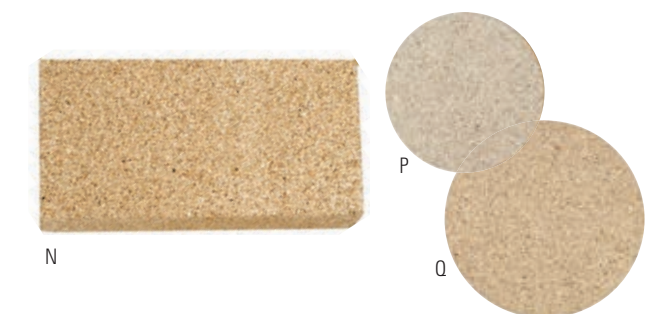



**ROTATING NON-ASBESTOS SOLDERING TABLE**

Lazy-Susan-style, grooved work surface disk. Rotates on ball bearings that provide 360 degree access. Ideal for soldering small parts.

Order # 54-11000

Item	Description	OD	12+	6+	1+
A	Soldering Table	4 1/2"	\$25.76	\$27.27	\$30.30
B	Replacement Disk	4 1/2"	\$9.48	\$10.04	\$11.15



**HONEYCOMB DESIGN CERAMIC SOLDERING BLOCKS**

Lightweight blocks that contain hundreds of tiny holes to accelerate heat loss from parts being soldered. Holes also provide anchor points for pins or wires used to hold parts in place on the surface. Contains no asbestos. Withstands temperatures up to 2,000 degrees Fahrenheit (1,093.3 degrees Celsius).

Order # 54-17840

Item	Description	WxLxH	12+	6+	1+
C	Soldering Block	3 3/4"x5 1/2"x1/2"	\$7.84	\$8.82	\$9.80
D	Soldering Block	5 1/2"x7 3/4"x1/2"	\$11.16	\$12.11	\$13.45



**HIGH-TEMP SOLDERING BLOCK FOR PLATINUM**

This non-asbestos soldering board made of silquar will take temperatures up to 3,200 degrees Fahrenheit (1,093.3 degrees Celsius).

Order # 54-1800

Order #	Description	WxLxH	12+	6+	1+
54-1800	Soldering Block	4 1/4"x4 1/4"x1/2"	\$20.47	\$21.36	\$22.25

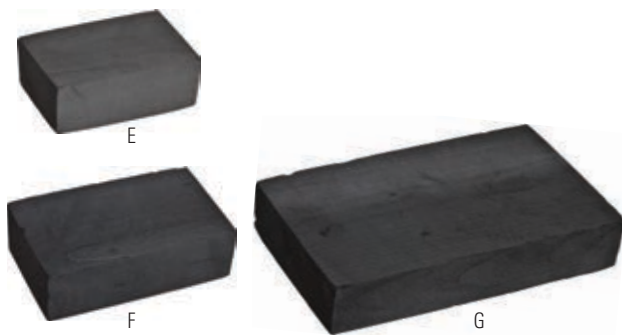

**CHARCOAL SOLDERING BLOCKS**

Made from select, close-grained, knot-free wood chemically prepared by a special process, the charcoal under flame creates a reducing atmosphere and reflects heat back into the work for effective soldering conditions. Heat is reflected to provide uniform intensity. Soft enough to be easily punctured to hold soldering work. Wrapping block in binding wire before use will retard cracking.

Order # 54-18940

Item	Description	WxLxH	12+	6+	1+
E	Soldering Block	2 1/4"x3 1/2"x1 1/2"	\$7.10	\$7.52	\$8.35
F	Soldering Block	3"x4 3/4"x1 1/2"	\$10.71	\$11.61	\$12.90
G	Soldering Block	4"x7"x1 1/2"	\$21.87	\$23.72	\$26.35



**MAGNESIA SOLDERING BLOCK**

Porous fibrous non-asbestos fire-proof material used as a surface for soldering. Reflects heat and is soft enough to allow work to be pinned or pressed into the block for wireless soldering. Longer lasting than charcoal. Withstands temperatures up to 2,000 degrees Fahrenheit (1,093.3 degrees Celsius).

Order # 54-1888

Order #	Description	WxLxH	12+	6+	1+
54-1888	Soldering Block	3"x6"x1 1/2"	\$4.69	\$5.09	\$5.65

**SOLDER BOARD WITH GROOVES**

Non-asbestos. Flat on one side with grooves on the other, this is used for holding shanks, chains, etc. Withstands temperatures up to 2000° F. Measures 7 1/2" x 7 1/4" x 7/8".

Order #	Description	WxLxH	12+	6+	1+
54-1789	Solder Board	7 1/2"x7 1/4"x7/8"	-	\$29.79	\$33.10



**PREMIUM SOLDERING PICK WITH SHIELD**

This soldering tool makes your job easier. With its non-slip grip and stainless steel heat shield, you'll enjoy extended use while protecting your hands. It is made in the USA and comes with two 1/16" diameter tungsten steel tips.

Order # 48-3000

Item	Description	12+	6+	1+
A	Replacement Tungsten Pick	\$8.54	\$9.05	\$10.05
	Soldering Pick with Shield	\$16.28	\$17.24	\$19.15



**TITANIUM SOLDERING PICS**

Titanium machined tip is built to last. Grooved aluminum handle is designed to quickly transfer heat away from the operator. Available in three colors for jobs that require different gold karats and colors. Overall length 6 1/4". Tip length 1 5/8". Not for use with platinum.

Order # 54-18170

Item	Description	Color	12+	6+	1+
B	Titanium Soldering Pick	Red	\$4.76	\$5.04	\$5.60
C	Titanium Soldering Pick	Gold	\$4.76	\$5.04	\$5.60
D	Titanium Soldering Pick	Blue	\$4.76	\$5.04	\$5.60



**SOLDERING PICKS**

**E. Niobium Pick:** Hardwood handle soldering picks Niobium point soldering pick has a melting temperature of 4,474 degrees Fahrenheit (2,467.8 degrees Celsius). Safe for platinum silver gold or any other

**F. Titanium Pick:** Wood handle with sharp-pointed tip for placing holding and positioning solder in just the right place. Solder will not adhere and wood will not heat up. Not for use with platinum.

**G. Tungsten Pick:** Tungsten high-temperature soldering pick is designed specifically for platinum. This pick withstands higher temperatures than titanium and does not contaminate platinum.

Order # 54-18050

Item	Description	12+	6+	1+
E	Niobium Pick	\$6.42	\$6.80	\$7.55
F	Titanium Pick	\$5.53	\$5.85	\$6.50
G	Tungsten Pick	\$6.42	\$6.80	\$7.55







**FIRESCOFF®**

Revolutionary spray ceramic coating that prevents oxidation and scale, acts as a flux, and features easy removal with just warm water. With Firescoff, no additional pickle flux is required, and no pickle solution is needed. Protects gemstones from heat oxidation in multiple soldering operations without waiting; consistent void-free, non-brittle, welds. Ideal for jewelry manufacturers, repair jewelers, and stone setters. Non-flammable. Odor-free, alcohol-free.

**Order # 54-4414**

Item	Description	Size	12+	6+	1+
A	Small Bottle	1 oz	\$9.90	\$10.49	\$11.65
B	Large Bottle	4½ oz	\$24.14	\$25.56	\$28.40
C	Bulk Dispenser	1000 ml bulk	\$193.34	\$201.74	\$210.15



**FIRESCOFF® RH CERAMIC FLUX FIRECOAT SPRAY**

Ceramic coating technology that protects and prevents rhodium plated jewelry from turning black during resizings or repair.

Order #	Description	12+	6+	1+
54-4412	Ceramic Flux Firecoat Spray 125ml	\$31.88	\$33.75	\$37.50
54-4412	Ceramic Flux Firecoat Spray 30ml	\$9.05	\$9.81	\$10.90



**DANDIX® PLASTIC FLUX**

Paste flux for use in low temperature brazing and silver soldering. Dissolves oxides at 800 degrees Fahrenheit (426.7 degrees Celsius) and is fluid between 1,100 degrees Fahrenheit and 1,600 degrees Fahrenheit (593.3 degrees Celsius and 871.1 degrees Celsius). Contains no fluoride.

**Order # 54-44160**

Item	Size	12+	6+	1+
D	16 oz	\$12.75	\$13.50	\$15.00
E	8 oz	\$8.50	\$9.00	\$10.00
F	1½ oz	\$3.78	\$4.10	\$4.55



**GRIFFLUX NO. 1**

A hard-soldering paste flux for use on all ferrous and non-ferrous metals and alloys.

**Order # 54-80700**

Item	Size	12+	6+	1+
G	1½ oz	\$4.92	\$5.14	\$5.35
H	8 oz	\$9.34	\$9.74	\$10.15
J	16 oz	\$16.24	\$16.94	\$17.65



**GRIFFITH SOFT SOLDER FLUX**

For use with lead-tin and lead-tin bismuth solders that melt below 450°F.

Item	Order #	Size	12+	6+	1+
A	54-8089	4 oz	\$6.07	\$6.34	\$6.60
B	54-8090	8 oz	\$8.19	\$8.54	\$8.90

**MAGIC BORIC® SOLDERING DIP**

Safe, non-flammable, longer-lasting soldering dip with built-in flux. Use for coating before soldering. No flux needed.

Item	Order #	Size	12+	6+	1+
C	54-4415	16 oz	\$7.91	\$8.26	\$8.60

**BATTERNS® SELF-PICKLING FLUX**

Self-pickling, hard-soldering flux is used for hard soldering on gold, silver, or platinum. Coat piece with this mixture of boric acid and denatured alcohol.

**Order # 54-40000**

Item	Size	12+	6+	1+
D	1 oz	\$2.32	\$2.52	\$2.80
E	3 oz	\$3.44	\$3.87	\$4.30
F	8 oz	\$4.15	\$4.50	\$5.00
G	16 oz	\$6.31	\$6.84	\$7.60
H	32 oz	\$11.33	\$12.29	\$13.65



**GRIFFITH SOFT SOLDER FLUX**

Use with precious metals which melt under 2000 degrees Fahrenheit.

**Order # 54-80800**

Item	Size	12+	6+	1+
J	1 oz	\$2.71	\$2.83	\$2.95
K	4 oz	\$3.45	\$3.60	\$3.75
L	8 oz	\$4.60	\$4.80	\$5.00
M	16 oz	\$8.37	\$8.74	\$9.10



**GRIFFITH PRIP'S FLUX**

A liquid hard soldering flux that prevents the formation of firecoat and firescale during soldering.

**Order # 54-80750**

Item	Size	12+	6+	1+
N	4 oz	\$3.82	\$3.98	\$4.15
P	8 oz	\$4.74	\$4.94	\$5.15
Q	16 oz	\$8.00	\$8.35	\$8.70
R	32 oz	\$11.50	\$12.00	\$12.50





A



B



C

D

E

**FLUXIT DISPENSER BOTTLE**

Dispenser bottle with 22-gauge needle tip for applying exact amount of flux.

Item	Order #	Description	12+	6+	1+
A	54-4015	Fluxit Bottle	\$4.68	\$4.95	\$5.50

**FLUX DISPENSER PUMP**

This compact dispenser pump is designed to dispense the right amount of flux into the well. The one-way pump holds the fluid in the well of the cap, preventing contamination of the unused fluid. For best results and to avoid clogging, the well should be emptied and the cap cleaned between use.

Item	Order #	Description	12+	6+	1+
B	54-4035	Flux Dispenser Pump	\$22.40	\$23.72	\$26.35

**SOLVENT DISPENSER**

These dispensers have no stopper or cap to remove. Just touch the dispensing dish with a brush, cloth, or other applicator and the solvent is brought to the surface the instant it is needed. Stainless steel valves seal contents in the bottle until used, preventing spills, dripping, and escaping fumes. Fluid pumped into the dish does not drip back into the bottle, keeping stored liquids uncontaminated. Made of static dissipative plastic with Teflon tube.

Order # 54-40360

Item	Description	Size	12+	6+	1+
C	Small	120 ml	\$16.19	\$16.90	\$17.60
D	Small Anti-Splash	120 ml	\$16.70	\$17.42	\$18.15
E	Large	180 ml	\$16.19	\$16.90	\$17.60

**GRIFFITH BORAX POWDER**

Used for making soldering and casting fluxes.

Order # 54-80200

Item	Description	Size	12+	6+	1+
F	Borax Powder	7 oz	\$5.08	\$5.72	\$6.35
	Borax Powder	16 oz	\$7.28	\$8.19	\$9.10

**GRIFFITH BORIC ACID POWDER**

Use as an anti-oxidizer during soldering or in making flux.

Order # 54-80350

Item	Description	Size	12+	6+	1+
G	Boric Acid Powder	7 oz	\$5.27	\$5.72	\$6.35
	Boric Acid Powder	16 oz	\$6.43	\$6.98	\$7.75

**GRIFFITH BORIC ACID GRANULES**

Use as an anti-oxidizer during soldering or in making flux.

Order # 54-80300

Item	Description	Size	12+	6+	1+
H	Boric Acid	7 oz	\$3.64	\$4.10	\$4.55
	Boric Acid	16 oz	\$6.23	\$6.75	\$7.50

**MAGIC BORAX™**

Borax Granular powder is an excellent, general purpose flux. Excellent for glazing clay crucibles to extend crucible life.

Item	Order #	Description	Size	12+	6+	1+
A	54-4432	Boric Acid Granular	16 oz	\$7.41	\$7.73	\$8.05

**MAGIC BORIC ACID POWDER®**

High-grade, superfine boric acid powder. Use as high-grade flux and deoxidizing agent. Can also be mixed with denatured alcohol to make soldering flux.

Item	Order #	Description	Size	12+	6+	1+
B	54-4433	Boric Acid Powder	16 oz	\$8.59	\$9.09	\$10.10

**MAGIC PICKLE®**

This safe pickle compound is a dry granular compound for cleaning and removing surface oxidation and fire scale. Produces a clean, bright surface. Requires heat. One tablespoon to one pint liquid.

Item	Order #	Description	Size	12+	6+	1+
C	54-4431	Pickle Compound	24 oz jar	\$7.31	\$7.63	\$7.95

**"BLACK MAGIC" PICKLE®**

A non-acid pickle can be used for all metals. No fumes. No corrosion. It is safe to use at the bench. Long lasting, not adversely affected by steel, this pre-measured dry compound is shipped in a one-gallon container. Fill with tap water for correct pickle formulation. Saves eight pounds in your shipping cost.

Item	Order #	Description	Size	12+	6+	1+
D	54-4435	Pickle Compound	1 gallon	\$9.69	\$10.26	\$11.40

**CITRIC ACID PICKLE**

Natures Touch Citric Acid Pickle is a mild solution. It can be used for sterling silver, gold, brass, copper, and stainless steel. This biodegradable solution is safe, yet effective.

Item	Order #	Description	Container Volume	12+	6+	1+
E	54-4600	Citric Acid Pickle	32 oz	\$11.56	\$12.24	\$13.60



A



B



C



D



E



F



G



H

Soldering Equipment and Supplies

Soldering Equipment and Supplies





**SPAREX PICKLE**

Dry granular, acid compound is used for pickling, cleaning, and removing surface oxidation and scale from copper and silver. This product is non-flammable and non-explosive. Requires heat.

Order # 45-12070

Item	Description	Size	12+	6+	1+
A	Pickle	2 1/2 lb bag	\$6.76	\$7.06	\$7.35
B	Pickle	10 oz can	\$3.68	\$3.84	\$4.00



**GRIFFITH PICKLE SAFE**

This dry, granular acid compound is used to pickle gold, silver, and other non-ferrous metal castings.

Order # 54-50200

Item	Description	Size	12+	6+	1+
C	Pickle Safe	10 oz	\$4.74	\$4.94	\$5.15
D	Pickle Safe	2 1/2 lb	\$9.43	\$9.84	\$10.25



**PICKLE POT**

Economical, pickle pot is made for basic pickling. It is well insulated with a stainless steel outer shell. Maximum temperature 150 degrees Fahrenheit. Comes with plastic lid to prevent the evaporation of the pickle solution.

Order #	Description	Size	12+	6+	1+
45-3015	Pickle Pot	16 oz	\$20.87	\$22.10	\$24.55



**FERRIS ELECTRIC PICKLERS**

Pickler automatically keeps solution at the right temperature. This prevents solution from boiling away. Plastic basket is included which will hold articles in solution.

Order # 45-30060

Item	Description	Size	12+	6+	1+
E	Pickler	12 oz	\$102.00	\$108.00	\$120.00
F	Replacement Basket	12 oz	\$16.41	\$17.37	\$19.30



**COPPER TONGS**

Use for pickling and acid solutions. Will not contaminate solutions or corrode.

Order # 57-06900

Item	Description	Length	12+	6+	1+
G	Curved Tip	8 1/2"	\$6.76	\$7.16	\$7.95
H	Fishtail Tip	8 1/2"	\$6.29	\$6.66	\$7.40

**SHG GEM GUARD**

The SHG Gem Guard is a two part solution that, when mixed together, can be applied to a stone to protect this stone from heat and splatter that may result from nearby welds. The solution mixes up quick, is easily applied, hardens, and protects within minutes, and cleans up in seconds. After the welding is complete, the Gem Guard can be easily scraped off with a fingernail and washed off with running water.

Order #	Description	1+
14-0139	SHG Gem Guard	\$30.95



**GREEN STOP-OFF PEN**

The most effective means to prevent solder flow, this product has been used by Stuller's own assembly department for many years. Test on a piece of paper before you solder. Shake well then use like a felt-tip marker to mask the areas where you do not want the solder to flow. Use the ultrasonic for cleaning after the solder job is complete.

Order #	Description	12+	6+	1+
54-4039	Green Stop-Off Pen	\$10.20	\$10.80	\$12.00



**THERMO SHIELD**

The new, revolutionary, environmentally safe, protective barrier for retarding the transfer of heat. This product will adhere to vertical, non-absorbent surfaces as well as to stones. You will no longer have to remove the stone. Dab the Thermo Shield on the area you would like to protect and hit it with the flame. No heat will transfer. Absorbs temperatures up to 3,000°F. Water soluble.

Order #	Description	12+	6+	1+
54-4030	Heat Blocker	\$16.02	\$17.37	\$19.30



**KOOL JOOL®**

Protects jewels from heat damage while soldering. Unnecessary to remove jewels from settings (except opals). The jewel will stay cool if flame is used for soldering. Rinses off in plain water. Eliminates oxidizing, will not turn when heated.

Order #	Description	12+	6+	1+
54-4026	Kool Jool	\$7.91	\$8.26	\$8.60



**MAGIC FLAME® CONCENTRATED SOLDERING COMPOUND, 8 OZ**

Use full strength for a superior, hard-soldering, paste flux. Can be thinned with water or alcohol for a great hard solder liquid flux.

- Temperature range 1100-1700 degrees Fahrenheit.
- Biodegradable
- Contains boric acid, borax, sodium flu borate.
- Excellent, fire-coat dip.

Order #	Description	Container Volume	12+	6+	1+
54-4440	Concentrated Soldering Compound	10oz	\$12.33	\$12.86	\$13.40





**TIX® FLUX**

A non-corrosive, liquid flux that works well with soft solder and has a melting temperature under 450 degrees Fahrenheit (232.2 degrees Celsius). Harmless to skin and clothing. Washes off with water even after drying.

Item	Order #	Description	Size	12+	6+	1+
A	54-4022	Flux	½ oz bottle	\$4.28	\$4.46	\$4.65

**TIX® ANTI-FLUX**

Liquid that brushes on to prevent solder from flowing to unwanted areas. Use for both hard and soft soldering.

Item	Order #	Description	Size	12+	6+	1+
B	54-4024	Anti-Flux	½ oz bottle	\$3.96	\$4.13	\$4.30

**PRO-CRAFT® YELLOW OCHRE**

When mixed with water or alcohol, yellow ochre creates a paste that is used to prevent solder flowing to unwanted areas such as previously soldered joints or the moving parts of a catch.

Item	Order #	Description	Size	12+	6+	1+
C	54-4055	Yellow Ochre	½ lb can	\$8.33	\$8.82	\$9.80

**GRIFFITH YELLOW OCHRE**

Mix with alcohol to produce an anti-flux for soldering.

Item	Order #	Description	Size	12+	6+	1+
D	54-4060	Yellow Ochre	2 oz jar	\$3.64	\$4.10	\$4.55

**GRIFFITH ANTI-FLUX**

Effectively prohibits the flow of solder to unwanted areas.

Item	Order #	Size	12+	6+	1+
E	54-4034	1 oz bottle	\$3.54	\$3.70	\$3.85

**SOLDER PRINTS™**

Solder Prints™ liquid formula quickly and easily exposes previously soldered joints before you heat the area, reducing work on older jewelry. - Apply to the jewelry surface using a non-metallic applicator or flux brush: solder joints will immediately show as darker lines, so you can see exactly where previous repairs have been preformed - Easily polish easy any joint discoloration

Order #	Description	12+	6+	1+
54-5500	Joint Detector	\$12.11	\$12.83	\$14.25



**TIX® SOLDER**

Hardest soft solder on earth, it has a melting point of 275 degrees Fahrenheit (135 degrees Celsius), and has a holding power of 4,300 PSI. Adheres to all ordinary, solder-able materials. Works well with gun, iron, torch, or soldering machine. No cadmium or bismuth, stays white, and does not tarnish. Can be used with silver.

Item	Order #	Description	Length	Per Unit	12+	6+	1+
A	54-4050	Tix Solder Sticks	3"	20	\$15.69	\$16.37	\$17.05

**STAY-BRITE SOLDER KIT**

High-strength silver-bearing solder that melts and flows at 430 degrees Fahrenheit (221.1 degrees Celsius). Cadmium-free and non-toxic. Provides strength without distortion caused by high temperature brazing. Retains bright silver finish after cooling. Kit contains 1/2 oz of solder and 1/2 oz flux.

Item	Order #	Description	12+	6+	1+
B	54-4020	Solder Kit	\$23.00	\$24.00	\$25.00



**MK3 PASTE SOLDER DISPENSER**

Manual solder dispenser designed to deposit paste solders with pinpoint accuracy. Use with Stuller paste solders syringes.

Order #	Description	12+	6+	1+
54-4010	MK3 Solder Dispenser	\$24.01	\$25.43	\$28.25



**DISPENSABLE BRAZING FLUX**

This product is a concentrated general-purpose brazing flux suitable for use on gold, silver, and most non-precious metals. The product is a homogenous blend of fluxing agents and a neutral binder that has been optimized for dispensing from syringes. This product is restrictive, which means that it tends to stay in place where it is applied. This allows excellent control over flux placement, usage, and effectiveness. Also, because of the tackiness of this product, it can be used as an aid in holding solder chips in the joint area.

Order #	Description	12+	6+	1+
54-4011	Dispensable Brazing Flux	\$2.76	\$2.93	\$3.25



**BINDING WIRE**

Bind parts together for soldering or stringing parts to be plated. Sold in 8 oz. spools.

Order # 43-63800		12+	6+	1+
Description	Wire Gauge			
Wire	24 Gauge	\$9.15	\$9.55	\$9.95
Wire	26 Gauge	\$7.87	\$8.21	\$8.55
Wire	27 Gauge	\$10.76	\$11.23	\$11.70
Wire	28 Gauge	\$10.86	\$11.33	\$11.80





# TESTERS



### PHOSVIEW™

This compact, self-contained screening device is designed to allow parcels of polished stones to be quickly analyzed to determine if they contain potential HPHT synthetics. PhosView cannot be used to screen for CVD synthetics, simulants or any natural diamond treatments. If any potential HPHT synthetics are indicated, built-in manipulator arms may be used to manually separate these from the remainder of the parcel. PhosView can accept colorless or near-colorless loose stones from the 0.003 carat (one third of a point, or 0.9mm) to one carat. Some set jewelry pieces may also be tested. PhosView is simple to operate: melee are placed in a removable sample tray which is part of the PhosView sample drawer. A single button is pressed to start a

special video mode which will indicate potential HPHT synthetics. If required one of the manipulator arms may be used to manually move these to a separate area of the sample tray while viewing them in real-time. If rings are being tested they may be placed on a conical mount in the sample drawer which is then closed. Rings may be rotated to check for any potential HPHT synthetics in real time. Other jewelry pieces may also be handled subject to their configuration and dimensions. Any stones which are indicated as potential HPHT synthetics should be submitted for further testing. Images may be saved for later use if required (requires a keyboard and mouse — not included).

What is Included —

- PhosView instrument
- IEC mains supply lead (county specific)
- Power supply
- Quick start guide
- Operating manual
- Test stone (for use when learning how to operate the instrument)
- One-year parts/service warranty

Order #	Description	1+
29-2000	PhosView	\$4,500.00



### PRESIDIUM® SYNTHETIC DIAMOND SCREENER

The Synthetic Diamond Screener was developed by Presidium to help screen out Type IIa colorless diamond, which is likely to be synthetic and created through chemical vapor deposition (CVD) or high pressure high temperature (HPHT) syntheses, from the natural Type Ia colorless diamond. When subjected to this deep UV irradiation, Type Ia and Type IIa diamonds each absorb different amount of UV light. Type IIa diamonds allow deeper UV light to pass through and thus its UV light absorption ability is low. This difference in the light absorption is significant enough to aid in differentiating between colorless Type Ia and Type IIa diamonds.

Item	Order #	Description	12+	6+	1+
A	56-7904	Diamond Screener	—	—	\$599.00
	56-7905	Presidium Universal Adapter 6V 600mA	\$18.54	\$19.34	\$20.15
	56-7906	Universal USB Adaptor 5V 500mA	\$18.54	\$19.34	\$20.15



A

### PRESIDIUM® MULTI TESTER III

The Presidium Multi Tester III is the only instrument needed to verify the authenticity of diamonds against moissanite, cubic zirconia, and other diamond simulants. Showcasing a new ergonomic design with a rubberized anti-slip grip, PMuT III promises greater ease of handling during testing. Presidium's multi tester is the world's first tester that tests for both diamonds and moissanite in a single instrument. Its measuring probes and electronics circuitries detect data from the gemstone being tested via a customized micro-controller, identifying diamonds and moissanite based on their thermal and electrical properties. PMuT III has a retractable probe tip that ensures consistent pressure against the gemstone during testing for more reliable results. With the industry's thinnest probe tip size of 0.6mm, PMuT III tests diamonds as small as 0.02 carats.

Item	Order #	Description	12+	6+	1+
B	56-7834	Multi Tester	—	—	\$209.00
	56-7905	Presidium Universal Adapter 6V 600mA	\$18.54	\$19.34	\$20.15



B

### PRESIDIUM® GEM INDICATOR

The Presidium Gem Indicator is the only handheld tester in the industry specifically for colored gemstones. It indicates up to 31 different types of colored gems based on their thermal conductivity and even features a color input function that allows users to select from a range of 12 common colors, thereby achieving more accurate results. It is recommended to use the Presidium Gem Indicator in environments at ambient temperatures of 23°C - 27°C. Calibration using the provided calibration disk is also recommended when starting to use the product or when using the product in different environments.

Item	Order #	Description	1+
C	56-7903	Probe Tip for PGI	\$46.00
D	56-7903	Gem Indicator	\$259.00



C



D

**ADAMAS BY PRESIDIUM®**

The epitome of style and cutting-edge technology, Adamas diamond and moissanite tester comes with changeable tips and allows you to replace any worn or damaged probe tip yourself, eradicating and reducing any equipment downtime. It can also be used with the special micro probe tip that is able to authenticate melee diamonds as small as 0.01 carats. A hallmark of design featuring dynamic LED display and a sleek ergonomic grip, the premium choice Adamas tester is precise, reliable, and made of excellent quality.

**Features—**

- Easy-to-use interchangeable probe tip
- Industry's thinnest probe tip for testing diamonds
- World's only micro probe tip
- In-built memory chip for up to 500 test records
- Dynamic display with super bright micro LED for clear and distinct results
- Sleek chrome-brushed ergonomic grip
- USB port for alternative power source and connectivity

**Benefits—**

- Detects diamonds, moissanite, and simulants instantly with metal alert
- Accurate testing on diamonds as small as 0.02 carats and diamond melees as small as 0.01 carats (with micro probe tip)
- Retractable thermoelectric probe tip that ensures constant pressure between probe and gemstone, for enhanced accuracy
- Light and portable for convenience
- Compatible with web application OMI to save and share your testing results

**Specifications—**

- Power & Battery
- 3-AAA Alkaline batteries (approximately 12 hours of continuous use)
  - USB Port to be used with USB cable and appropriate Presidium Universal USB Power Adapter Recommended Operating Conditions
  - Optimal Operating Temperature: 18°C - 27°C (65°F - 80°F)
  - Storage Temperature: 14°C - 51°C (57°F - 124°F)



Order # 56-7850

Item	Description	1+
A	Adamas	\$399.00
B	Micro tip	\$69.00
C	Replaceable probe tip	\$69.00

**PRESIDIUM® GEM TESTER**

Presidium Gem Tester provides a quick and easy way to identify diamonds and separate common colored gemstones from one another based on their thermal conductivity. Coated gemstones can also be generally tested with the Presidium Gem Tester. This unit also has a retractable probe tip that ensures consistent pressure against the gemstone during testing for more reliable results. With the industry's thinnest probe tip size of 0.6mm, the Presidium Gem Tester tests diamonds as small as 0.02 carats.

**Features—**

- Detachable probe pen with retractable thermoelectric probe tip that ensures constant pressure between probe and gemstone
- Industry's thinnest probe tip (0.6mm) for testing diamonds as small as 0.02 carats.
- Metal alert buzzer to ensure that probe tip is in contact with gemstone during testing.
- Clear and easy-to-read analog dial.
- Can differentiate between 15 types of gemstones.
- Built-in diamond and simulant test disc for reference

**Benefits—**

- Identifies diamonds and most colored gemstones
- Tests both polished and unpolished gemstones
- Tests gemstones as small as 0.02 carats
- Consistent and reliable results every time
- No waiting time between tests
- Simple and easy to use
- Runs on batteries (2-AAA)
- AC port to be used with appropriate Presidium
- Power adaptor (not included)
- Optimal operating temperature: 18°C - 27°C (65°F - 80°F)
- Storage temperature: 10°C - 51°C (50°F - 124°F)
- Replacement probe tip 56-7704



Item	Order #	Description	12+	6+	1+
D	56-7703	Presidium Gem Tester	\$191.17	\$202.41	\$224.90
E	56-7704	Replacement 6-Prong Pen	—	—	\$70.70

**GEMORO® TESTERS**

**A. GEMORO® TESTEROSSA®**

This next-generation ultimate tester for diamond fraud protection features enhanced moissanite testing technology for low conductivity stone identification. This innovative Gemoro tester has the sleekest ergonomic shape available that comfortably rests in and on your hand when held. It has intuitive finger grip pads for increased user-friendliness and ease of use. LED stone illumination and UV fluorescence detection. Precision retractable probe-tip with enhanced durability, and indestructible polycarbonate housing with molded rubber base for increased impact resistance if dropped. It features a super-fast 10 second warm-up time, plus a user programmable, talking (English, German, Italian, Spanish, French, Russian, Chinese, Japanese, and Arabic) or ringtone sounds, and glowing light bar/probe tip for quick stone identification (Green = Diamond, Blue = Moissanite, Yellow = Sapphire, and Red = Metal Alert). It even has a metal alert warning feature that informs you if the setting is touched, plus an auto-off function if accidentally left on. It can easily identify genuine sapphire watch crystals too. Includes a next-generation, low-profile Gemoro Ultradock 3 charging station, adjustable handy Gemoro Test Stone Magnifier attachment, loose stone holder, multi-voltage AC adapter, and comes stored in carbon-fiber style carrying case. Powered by a Micro USB or with its included rechargeable NiMH batteries (user may substitute 3-AAA alkaline batteries if desired). An unprecedented 10-year probe tip warranty and lifetime limited replacement warranty on the unit. Designed in the USA.



**B. GEMORO® ULTRA TESTER III**

Simultaneous diamond and moissanite tester that identifies, detects, and separates diamond from CZ and moissanite. Uses state-of-the-art ULTRA digital electronics, coupled with its even greater testing sensitivity make this tester the industry's most accurate, reliable, and popular combination tester in its class. GemOro sets the standard for the ultimate protection against diamond simulant fraud.



**C. GEMORO® PRO-D™ III TESTER**

The engineers at GemOro Superior Instruments have developed an enhanced version of their second generation PRO-D II simultaneous diamond and white sapphire tester. The third generation PRO-D 3 tester design is sleeker and more ergonomic and has even better testing sensitivity than before. Known for accuracy and reliability, GemOro sets the standard for protection against diamond simulant fraud. Patented.

**D. GEMORO® PRO-M III**

The engineers at GemOro Superior Instruments have developed an enhanced version of their second generation PRO-M II moissanite tester features advanced exclusive moissanite testing technology capable of identifying the widest range of the electrically conductive moissanite material available, including the new super low electrically conductive moissanite produced by Charles & Colvard Created Moissanite®. The PRO-M 3 is the only standalone moissanite tester recommended by Charles & Colvard. The third generation PRO-M 3 tester design is even sleeker and more ergonomic and has even better testing sensitivity than before. Known for accuracy and reliability, GemOro sets the standard for protection against diamond simulant fraud.



Item	Order #	Description	12+	6+	1+
A	56-7838	Gemoro® Testerossa	—	—	\$299.00
B	56-7830	GemOro® Ultra Tester III	—	—	\$199.00
C	56-7831	GemOro® Pro-D III™	—	—	\$119.00
D	56-7832	GemOro® PRO-M III	\$101.15	\$107.10	\$119.00
E	56-7833	GemOro® UltraDock™ III	\$22.95	\$23.95	\$24.95





A



B

**GEMLOGIS® CIEL 3-IN-1 MULTI TESTER**

A. The Gemlogis Ciel One combines thermal and electrical conductivity to distinguish the difference between diamond, moissanite and simulant. The Ciel One uses “Visible Violet Light” technology to illuminate the Moissanite which excites the atoms and improves electrical conductivity. This facilitates the tester in detecting Forever One™ Moissanite. The Ciel One also works seamlessly with the Pistachio Referential Meter to indicate a variety of popular gemstones such as sapphire, topaz, emerald and glass.

**Features—**

- “Visible Violet Light” technology to detect the Forever One™ Moissanite
- High-tech infrared innovation
- Portable and pocket-size for convenience of all users
- Quick & accurate testing of stones as small as 0.02 regardless of shape, rough, cut, loose, or mounted
- Includes lanyard, metal stone rest, and charging adapter
- Retractable tip maintains constant pressure against stone
- Two-year warranty
- Requires 3-AAA batteries

**PISTACHIO REFERENTIAL METER**

B. Designed to further expand the analog readings displayed on the Gemlogis Ciel 3-in-1 tester and Azure gem tester. It provides an instant, simple, and laboratory proven way to segregate diamond, moissanite and a variety of popular gemstones at an affordable price. This unique instrument communicates with the main unit, Gemlogis CIEL/AZURE, via an infrared interface that provides wireless usability.

**Features—**

- Foolproof reference test disc for diamond, simulant, and glass to ensure that the device provides accurate test results
- Testing size above 0.002 carats of any shape regardless of loose or mounted stones
- Batteries will last up to 80 hours of continuous usage
- Built-in power down function after 10 minutes of inactivity to maximize battery life.

Item	Order #	Description	1+
A	56-7712	Multi Tester	\$277.48
B	56-7713	Referential Meter	\$168.55



VIDEO

Find added video content on [Stuller.com/VideoCenter](http://Stuller.com/VideoCenter).



VIDEO

Find added video content on [Stuller.com/VideoCenter](http://Stuller.com/VideoCenter).

**GEMLOGIS® AZURE DIAMOND TESTER**

The Gemlogis Azure electronic diamond tester distinguishes diamonds from diamond simulants. It features a fast warm-up time and provides an instant test result on loose or mounted stones. Azure also communicates with PISTACHIO add-on tool (sold separately) via an infrared system to provide further analysis on the specific simulant or colored gemstone.

**Features—**

- Testing size above 0.02 carats of any shapes regardless of loose or mounted stones
- Retractable test tip designed to maintain a consistent pressure against the stones to avoid damages when excessive force is applied
- Operates on AAA alkaline batteries (included). Lasts up to two hours.
- Includes carry pouch and aluminum stone rest for handling loose stones
- Azure has a built-in power down function to maximize battery life span after 10 minutes of inactivity
- LED bar indicator: GREEN = Diamond or moissanite YELLOW = Metal RED ZONE (Centre LED's) = Simulant indication Round RED LED = Low battery warning I.R = Infrared signal READY = Ready for use
- Fast tip warm-up time of approximately 10 seconds
- Working temperature: 65°F to 86°F, relative humidity below 80%

Order #	Description	1+
56-7711	Diamond Tester	\$134.64

**GEMLOGIS LAPIS ONE**

The LAPIS ONE is a highly accurate, rechargeable multi tester that will distinguish the difference between diamond, moissanite, simulant and metal. The LAPIS ONE uses “Visible Violet Light” technology to illuminate the Moissanite which excites the atoms and improves electrical conductivity. This facilitates the tester to detect the Forever One Moissanite. The LAPIS ONE also features a unique ATC Solution (Ambient Temperature Compensation) for increased accuracy.

**Features—**

- “Visible Violet Light” technology to detect the Forever One Moissanite
- Unique ATC Solution
- Rechargeable Lithium Battery
- Retractable Tip maintains constant pressure against stone.
- Includes a lanyard, metal stone rest and charging adapter
- Quick & accurate testing of stones as small as 0.02 regardless of shape, rough, loose or mounted
- 10 hours of continuous operation
- Rechargeable Lithium Battery
- Two-year warranty

Order #	Description	1+
56-7715	Lapis	\$199.00



**CERES DUAL XL TESTER**

Differentiate between natural diamond and all common simulants, as well as moissanite. Operates on three AAA nickel-cadmium rechargeable batteries or on wall adapter (not included).

Order #	Description	1+
56-7807	Dual XL Tester	\$239.00



**CERES RELIANCE DIAMOND TESTER**

- AC powered only, no battery
- Metal warning buzzer
- Spring-loaded tip
- Auto shut-off
- Fast, four-second warm-up time
- Loose stone holder
- Diamond/simulant test plate
- Limited warranty does not cover tip, batteries, or adapter.

Item	Order #	Description	1+
A	56-7804	Diamond Tester	\$135.00
B	56-7805	Adapter	\$21.40



**CERES AC MODEL DIAMOND TESTER**

- AC powered only, no battery
- Metal warning buzzer
- Spring-loaded tip
- Auto shut-off
- Fast, four-second warm-up time
- Loose stone holder
- Diamond/simulant test plate
- Limited warranty does not cover tip, batteries, or adapter.

Order #	Description	1+
56-7806	Reliance Diamond Tester	\$120.00



**CERES CZECKPOINT DIAMOND TESTER**

- AC powered only, no battery
- Metal warning buzzer
- Spring-loaded tip
- Auto shut-off
- Fast, four-second warm-up time
- Loose stone holder
- Diamond/simulant test plate
- Limited warranty does not cover tip, batteries, or adapter.

Order #	Description	1+
56-7800	Checkpoint Diamond Tester	\$129.95







Back view showing pen holder

**GEMORO® AURACLE AGT3 DIGITAL GOLD & PLATINUM TESTER**

The advanced digital AGT3 is the ultimate verification instrument for gold and platinum testing. This state-of-the-art portable handheld tester has exceptional precision, is simple to use, and in seconds, provides accurate results showing both the digital karat value and gold percentage

- Tests all colors of gold from 6K to 24K and tests platinum
  - Alphanumeric LCD display shows both karat value and gold percentage
  - Two test modes: Fast Test Yellow and Enhanced Mode
  - Easy one-step calibration using either 14K or 18K yellow gold
  - Scratch resistant, durable nickel-plated stainless steel testing plate
  - Auto-check pen probe function
  - Sleek, contoured, and ergonomic design
  - Built-in storage compartment for pen probe
  - Easy-to-read LCD display
  - Automatic low battery indicator
  - Follow easy steps to identify non-gold, gold-plated, and gold-filled as NA
  - Simply touch pen probe to filed gold or platinum. Results are shown in seconds
  - Replaceable pen probe provides thousands of tests with proper care
  - Compact and portable
  - Powered by 9V alkaline battery (included) or 100V-240V AC adaptor
- Includes AGT3, pen probe, file, battery, AC adaptor, and rubberized carrying case.

Order # 56-76130

Item	Description	1+
A	Digital Tester	\$549.00
B	Replacement Pen	\$25.20

**GEMORO® AURACLE AGT BLUE MOBILE BLUETOOTH GOLD AND PLATINUM TESTER 10K-24K**

The revolutionary and best-performing AuRACLE gold tester from GemOro has evolved to a Bluetooth mobile version that makes it faster, easier and more convenient than ever before.

- Works with Low-Energy Bluetooth Apple and Android devices (Note: Android devices require Lollipop version OS or newer.)
- Compact and pocket-sized — No wires required
- Automatically calculates your unique buying price
- Automatically generates detailed email receipts for both your business and customer
- One touch easy calibration for consistent results
- May be calibrated using 10K, 14K, 18K, 22K, 24K, or platinum
- World's best performing gold testing technology with unmatched accuracy
- Tests all colors of gold in 10K, 14K, 18K, 22K, 24K, and platinum
- Follow easy steps to identify non-gold, gold-plated, and gold-filled as NOT GOLD
- Simply touch pen probe to gold or platinum for results
- Pen probe provides thousands of tests with proper care
- No messy gel. No staining chemicals. No dangerous acid.
- Includes AGT BLUE™ with built-in testing plate, pen probe, file, carrying case, and easy-to-follow tutorial instructions (mobile device not included)
- One-Year Limited Warranty

Order #	Description	1+
56-7615	Auracle AGT Blue	\$399.00



Phone not included



**GXL-NEXT TESTER**

The GXL-Next is the most complete electronic tester in the world. With the ability to test gold, silver, and platinum, it is the only tester you'll ever need. This tester has a full range of karat determination from 6 to 24 karats. The quick mode feature instantly test and measures yellow gold in 10, 14, 18, 20, 22, and 24 karats. Also the new mode allows for testing without the push of a button. the GXL-Next does require calibration with each use and is capable of 1000+ clear and clean per cartridge. Our liquid testing solution is harmless and contains no toxic chemicals.

Item	Order #	Description	1+
A	56-7620	GXL-Next Tester	\$549.00

Order # 56-76200

Item	Description	1+
B	Silver Testing Solution	\$18.60
C	Gold Testing Solution	\$18.60
D	AC/DC Power Supply	\$20.60
E	Silver Sensor	\$51.55
F	Sensor	\$51.55
G	Sensor Cap	\$3.15
	Test Wire Assembly	\$10.30
	Plastic Test Plate with Tri Wire	\$20.60
	Stainless Steel Test Plate with 2 Screws	\$15.45

**GXL-24 PRO GOLD TESTER**

State-of-the-art electronic gold testing technology allows for the measurement of low to high karat gold products. Assures the buyer of gold content in the most critical gold alloys. UL listed and includes a three-year warranty. Operates on two 9-volt batteries (not included).

Item	Order #	Description	WxLxH	1+
H	56-7630	GXL-24 Pro Gold Tester	12"x10"x3"	\$342.10

**GT-4000 GOLD TESTER**

Accurately measures white, yellow, pink, and green gold along with platinum in a full range to 24 karat. Accurate to the nearest karat in the 6 to 18 range, plus 20, 22, and 24 karat readings. Ecologically safe and does not mix harmful chemicals. UL listed and includes a three-year warranty. Operates on two 9-volt batteries.

Item	Order #	Description	WxLxH	1+
J	56-7635	GT-4000 Gold Tester	12"x9"x1 3/4"	\$344.80

**GT-3000 GOLD TESTER**

The most accurate low-cost tester available is backed by dependable service. The GT-3000 measures white, yellow, pink, and green gold in a full range of values from 6 to 18 karat. No mixing of chemicals or fluids. UL Listed.

Item	Order #	Description	WxLxH	1+
K	56-7640	GT-3000 Gold Tester	12"x9"x1 3/4"	\$227.15

**REPLACEMENTS FOR GXL AND GT TESTERS**

Order # 56-76470

Item	Description	1+
L	Pro Cleaning Solution	\$17.70
M	Replacement Tester Gel Tube	\$21.60
N	Replacement 4000 or 3000 Sensor	\$61.05







**MIZAR™ METAL TESTERS**

These electronic gold testers accurately and quickly determine gold karat values of yellow, white, green, and red gold, showing results on their LED displays. These units can also help identify platinum and can distinguish non-gold or gold plate for the true karat gold. Mizar electronic gold testers are very reliable, safe, fast, portable, and very easy-to-use.

- Note: For accuracy, all testers should be tested on a regular basis
- Sold with chemicals and has a six month shelf life after initial opening
- Made in the USA

**MIZAR™ ET18**

Determines gold karat values equal to or greater than 10K, 14K, 18K gold, and helps identify platinum. The ET 18 uses a 9-volt battery and has a one-year limited manufacturer's warranty.

Item	Order #	Description	1+
A	56-7603	ET18 Gold Tester	\$114.70
B	56-7601	Replacement Chemical	\$29.45

**MIZAR M24**

Determines 9K, 10K, 12K, 14K, 16K, 18K, 20K, 22K and 24K in seconds. Uses a 9 volt battery. Two-year limited manufacturer's warranty.

Item	Order #	Description	1+
C	56-7605	M24 Gold Tester	\$199.00
D	56-7606	Replacement Chemical	\$31.65

**DELUXE TEST ACID KIT**

A must-have for purchasing, appraising, and testing precious metals, this kit includes an eight-compartment wooden box, test acid for 10K, 14K, 18K, 22K, and silver, a gold testing star plate, and a black glass testing stone.

Item	Order #	Description	12+	6+	1+
E	56-0809	Deluxe Test Acid Kit	\$116.24	\$123.08	\$136.75
	56-8010	10K Gold	\$2.34	\$2.48	\$2.75
	56-8014	14K Gold	\$2.34	\$2.48	\$2.75
	56-8018	18K Gold	\$2.34	\$2.48	\$2.75
	56-8022	22K Gold	\$2.34	\$2.48	\$2.75
	56-8030	Silver	\$2.34	\$2.48	\$2.75

**GLASS BOTTLE TEST SET W/ STONE**

Use to appraise and test gold, silver, platinum, brass, nickel, and German silver. Shipped in a wooden case which contains three acid bottles with ground-glass stoppers and applicators, test stones, and a set of five testing needles. Acids not included.

Item	Order #	Description	1+
F	56-0807	8 Slot Box (only)	\$17.45
G	56-0806	3 Bottle Test Kit	\$78.40
H	56-0805	Deluxe Slot Box	\$22.70

**NEUTRALIZER SOLUTION**

The JSP neutralizer will prepare a test stone for accurate testing and also help spare your fingers and clothes from burns and stains while using gold testing acid. Simply drop the formula onto the test stone and clean with a tissue to prevent cross contamination with previous tests. If test acid comes in contact with skin or other objects, rub the neutralizing solution on the spill to stop further damage.

Item	Order #	Description	Container Volume	12+	6+	1+
J	56-8000	Neutralizer Solution	5 oz	\$7.14	\$8.16	\$10.20



**ACID BOTTLES**

Replacement bottles for holding chemicals used to test the accuracy of metals. Acids not included.

Item	Order #	Description	Container Volume	12+	6+	1+
A	56-9000	Square Acid Bottle	½ oz	\$5.52	\$5.76	\$6.00
B	56-9001	Round Acid Bottle	1½ oz	\$19.50	\$20.35	\$21.20



**TEST STONES**

Use for testing the karat value of gold. Rub the article to be tested and a test needle on the stone. Apply a test solution to determine karat value.

Item	Order #	Description	WxLxThickness	12+	6+	1+
C	56-7100	Stone	1½"×2"×1½"	\$13.05	\$13.82	\$15.35
D	56-7140	Genuine Arkansas	1½"×2½"×¼"	\$17.89	\$18.95	\$21.05
E	56-7101	Natural River Danube	1½"×2½"×¼"	\$11.35	\$12.02	\$13.35
F	56-7102	Black Glass	1½"×2½"×¾"	\$4.76	\$5.04	\$5.60

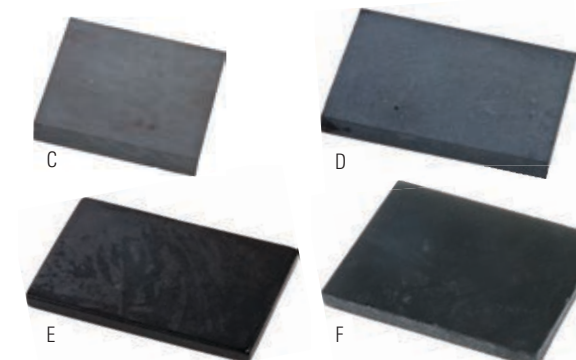

**TEST STONES**

Larger test stones are used for determining the karat value of articles being tested.

Item	Order #	Description	WxLxThickness	12+	6+	1+
G	56-7130	Glass Test Stone	3"×6"×¾"	\$16.83	\$17.82	\$19.80
H	56-7131	Natural Test Stone	4"×6"×¾"	\$24.06	\$25.47	\$28.30

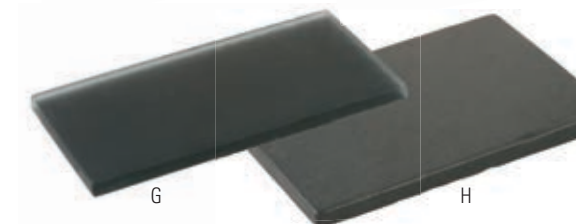

**RARE EARTH MAGNET**

Check for base metal (non-precious metals containing nickel or iron). Most items attracted by a magnet will not contain precious metal and most refiners will not accept them when you want to sell gold or silver. Neodymium magnets are brittle and can be broken or can splinter. One should wear gloves and protective glasses when handling these magnets. Magnets will lose their magnetic properties if heated above 175°F (80°C).

Order #	Description	WxLxH	12+	6+	1+
56-8001	Rare Earth Magnet	½"×2"×⅛"	\$9.48	\$10.04	\$11.15



**6 PIECE TEST NEEDLE SET**

Includes: 1- 8K, 1- 10K, 1- 12K, 1- 14K, 1- 18K, 1- 999S. Test needle pricing can change with the metal market.

Order #	Description	1+
56-7006	Test Needle Set	\$25.85



**GOLD TEST STAR PLATE**

Solid gold tips can be used to test for 10K, 14K, 18K, 21K, and 22K gold as well as silver. Measures 2¼" in diameter and is provided in a fitted case.

Order #	Description	12+	6+	1+
56-7007	Test Plate	\$72.97	\$77.27	\$85.85



# TWEEZERS

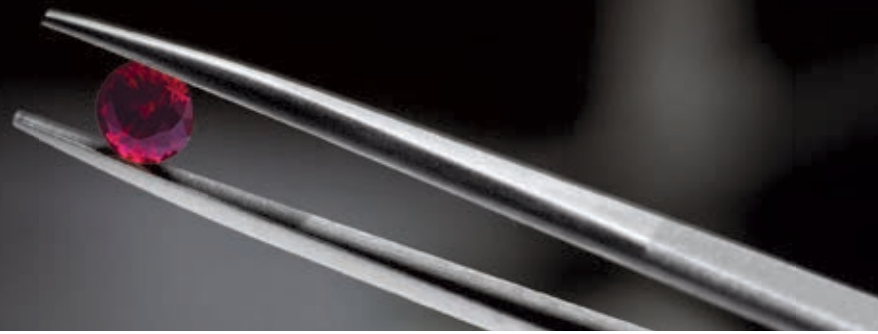

### IDEAL-TEK STAINLESS STEEL LOCKING TWEEZERS

Made of stainless steel, these tweezers feature serrated tips and handles as well as a locking system.

Order # 57-61880

Item	Description	Tip	Length	Color	12+	6+	1+
A	Ungrooved	Fine	6¼"	Dark Gray	\$18.66	\$19.76	\$21.95
B	Grooved	Medium	6¼"	Gray	\$18.66	\$19.76	\$21.95
C	Ungrooved	Fine	6¼"	Black	\$22.48	\$23.81	\$26.45
D	Grooved	Medium	6¼"	Black	\$22.48	\$23.81	\$26.45
E	Grooved	Fine	6¼"	Silver	\$18.66	\$19.76	\$21.95
F	Grooved	Fine	6¼"	Black	\$22.48	\$23.81	\$26.45



Fine



Medium/Grooved



### IDEAL-TEK STAINLESS STEEL NON-LOCKING TWEEZERS

Made of stainless steel, these tweezers offer serrated tips and handles.

Order # 57-61820

Item	Description	Tip	Length	12+	6+	1+
G	Ungrooved	Fine	6¼"	\$14.83	\$15.71	\$17.45
H	Grooved	Fine	6¼"	\$14.83	\$15.71	\$17.45
J	Ungrooved	Medium	6¼"	\$14.83	\$15.71	\$17.45
K	Grooved	Medium	6¼"	\$18.66	\$19.76	\$21.95
L	Grooved	Fine	6¼"	\$14.83	\$15.71	\$17.45



Fine



Medium/Grooved

### IDEAL-TEK TITANIUM TWEEZERS (NON MAGNETIC)

These tweezers are handcrafted to perfect tip symmetry and balance with polished edges and superior no-scratch/antiglare satin finish. The right tweezers and material make for a successful application.

Order # 57-61500

Item	Description	Tip	Length	Style	12+	6+	1+
A	Straight	Fine	4¾"	#1	\$24.44	\$25.88	\$28.75
B	Extra Sharp	Fine	4¾"	#3C	\$24.44	\$25.88	\$28.75
C	Sharp	Fine	5"	AA	\$16.11	\$17.06	\$18.95



### IDEAL-TEK PRECISION TWEEZERS

Made of anti-magnetic, anti-acid stainless steel, these tweezers have strong, thick, flat edges and a superior finish. Made of chromium, nickel, and molybdenum with low carbon content, applications for use include watchmaking, jewelry, and moderate chemical environments.

Order # 57-61600

#### STAINLESS STEEL

Item	Description	Tip	Length	Style	12+	6+	1+
D	Strong Flat Edge	Fine	4¾"	#00	\$17.72	\$18.77	\$20.85
E	Short	Fine	4¾"	#3C	\$17.72	\$18.77	\$20.85
F	Anti-Magnetic/Anti-Acid	Extra Fine	4¼"	#5	\$18.66	\$19.76	\$21.95
G	Curved	Extra Fine	4½"	#7	\$20.53	\$21.74	\$24.15
H	Anti-Magnetic/Anti-Acid	Extra Fine	5½"	SS	\$17.72	\$18.77	\$20.85
J	Anti-Magnetic/Anti-Acid	Fine	5"	AA	\$9.27	\$9.81	\$10.90
K	Anti-Magnetic/Anti-Acid	Fine	5"	MM	\$9.27	\$9.81	\$10.90

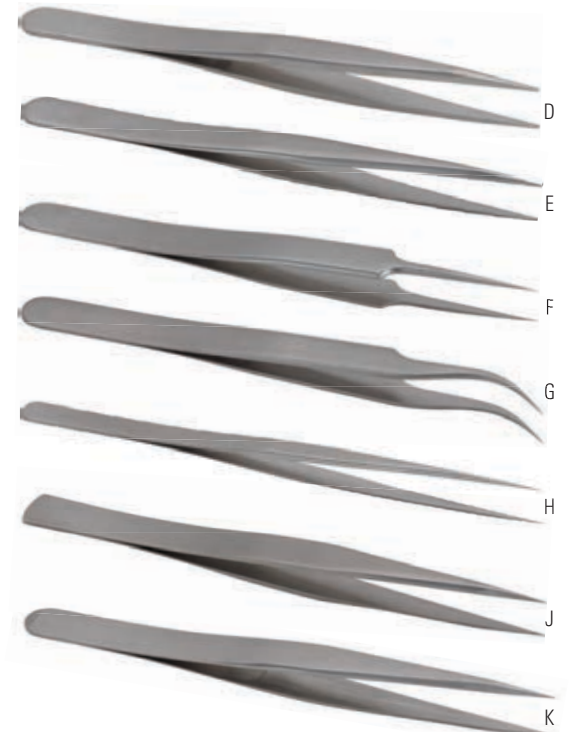

Order # 57-61940

#### INOX STEEL TWEEZERS

Item	Description	Tip	Length	12+	6+	1+
L	Diamond	Extra Fine	6¼"	\$20.61	\$21.83	\$24.25
M	Diamond	Fine	6¼"	\$20.61	\$21.83	\$24.25
N	Diamond	Medium	6¼"	\$20.61	\$21.83	\$24.25
P	Diamond	Large	6¼"	\$20.61	\$21.83	\$24.25
Q	Diamond	Extra Large	6¼"	\$20.61	\$21.83	\$24.25





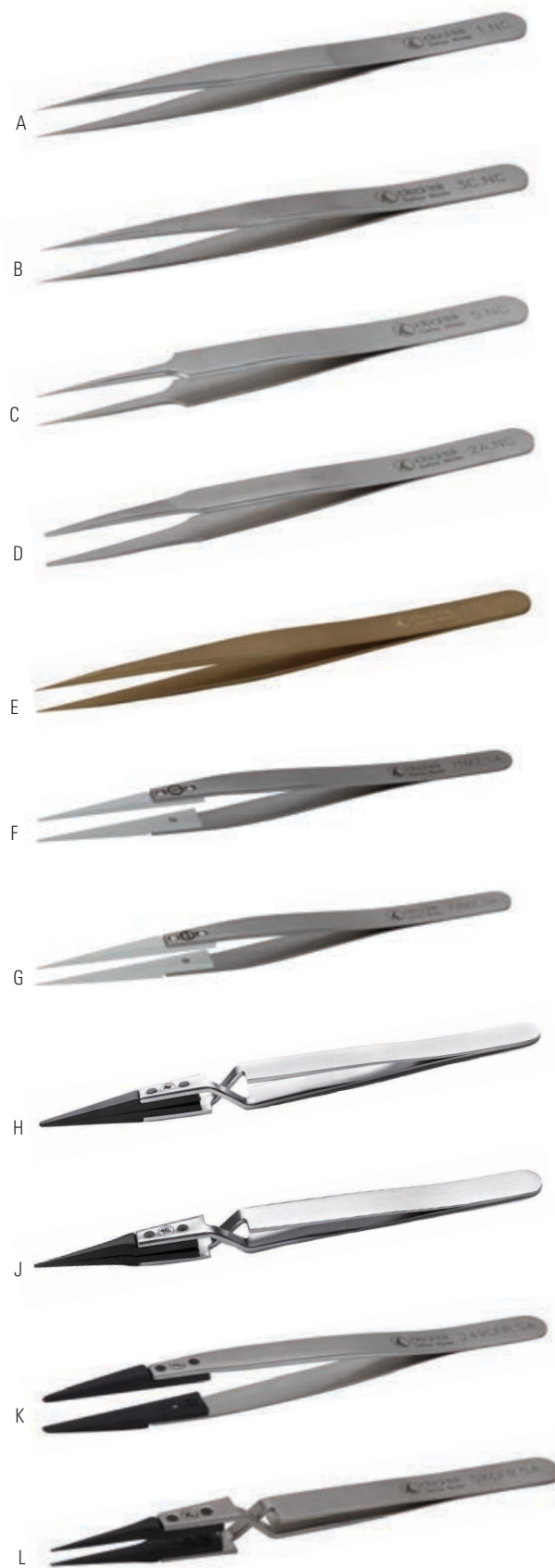

**IDEAL-TEK SUPER ALLOY TWEEZERS**

Made of chromium, nickel, and molybdenum super alloy, these tweezers offer strong, flat, accurate tips and a superior finish. Application includes aggressive chemical, salt, and acid environments.

**Order # 57-61700**

Item	Shape	Tip	Length	Style	12+	6+	1+
A	Flat Edge	Fine	4¾"	#1	\$27.16	\$28.76	\$31.95
B	Extra Sharp	Fine	4¼"	#3C	\$27.16	\$28.76	\$31.95
C	Sharp	Extra Fine	4¼"	#5	\$27.16	\$28.76	\$31.95
D	Flat Round	Fine	4¾"	#3C	\$27.16	\$28.76	\$31.95

**IDEAL-TEK BRASS TWEEZERS**

These tweezers offer strong, sharp tips. Made of a brass and copper zinc alloy, they offer good to excellent corrosion resistance to fresh water and steam. Applications include handling scratch-sensitive parts and watch components.

Item	Order #	Tip	Length	Style	12+	6+	1+
E	57-6178	Fine	5"	#2	\$17.81	\$18.86	\$20.95

**ZIRCONIA CERAMIC HIGH-TEMPERATURE TWEEZERS**

Ideal-Tek fine tip tweezers with replaceable ceramic tips (MZ-ZIRCONIA) feature an anti-magnetic, anti-acid stainless steel body.

Item	Order #	Description	Length	12+	6+	1+
F	57-7401	Fine Tip Tweezer	5¼"	\$37.53	\$39.74	\$44.15
G	57-7403	Very Fine Tip Tweezer	5¼"	\$37.61	\$39.83	\$44.25

**SOLDERING TWEEZERS**

Ideal-Tek fine, flat, round tip tweezers with replaceable plastic ESD PEEK (CP) tips feature a reverse action, anti-magnetic, anti-acid, stainless steel body.

Item	Order #	Description	Length	12+	6+	1+
H	57-6200	Soldering Tweezers	4¾"	\$26.99	\$28.58	\$31.75
J	57-6201	Soldering Tweezers	4¾"	\$26.99	\$28.58	\$31.75
K	57-7302	Tweezers with Strong Tips	5"	\$18.57	\$19.67	\$21.85
L	57-7304	Tweezers with Very Fine Tips	5"	\$21.68	\$22.95	\$25.50
	57-7303	Replacement Tips for 57-7302		\$5.61	\$5.94	\$6.60
	57-7305	Replacement Tips for 57-7304		\$5.61	\$5.94	\$6.60

**ANTI-MAGNETIC TWEEZERS**

These anti-magnetic, style 5 tweezers represent a quality unequalled in this price range. Offering an excellent matte finish and balance from the famous Dumont factory, the Dumont High-Tech line is a U.S. Eurotool® exclusive. Suitable for electronics, laboratories, light industry, optical, and camera assembly and repair.

Item	Order #	Description	Length	12+	6+	1+
A	57-5028	Dumont Anti-Magnetic Tweezers	4¾"	\$21.25	\$22.50	\$25.00

**DUMONT TWEEZERS**

These tweezers represent a quality unequalled in this price range. Offer an excellent matte finish and balance from the famous Dumont factory.

Item	Order #	Description	Length	12+	6+	1+
B	57-0445	Dumont Carbon Tweezers	4½"	\$39.70	\$42.03	\$46.70

**DUMONT DIAMOND TWEEZERS**

The Swiss-made Dumont diamond tweezers have finely serrated jaws to hold stones and small objects firmly. They offer an improved locking system, a superb finish, and balance with the legendary Dumont flexibility.

**Order # 57-60250**

Item	Tip	Metal Type	Length	12+	6+	1+
C	Fine	Stainless Steel	6½"	\$28.90	\$30.60	\$34.00
	Fine	Black Matte	6½"	\$28.90	\$30.60	\$34.00
D	Medium	Stainless Steel	6½"	\$28.90	\$30.60	\$34.00
E	Fine	Stainless Steel	6½"	\$30.60	\$32.40	\$36.00
F	Fine	Black Matte	6½"	\$33.41	\$35.37	\$39.30
	Medium	Stainless Steel	6½"	\$34.68	\$36.72	\$40.80
	Medium	Black Matte	6½"	\$33.41	\$35.37	\$39.30
G	Medium	Stainless Steel	6½"	\$30.56	\$32.36	\$35.95
H	Medium	Stainless Steel	6½"	\$26.35	\$27.90	\$31.00

**DUMONT TWEEZERS**

**Dumont – Finest Quality**  
**Dumont II – Excellent Quality**

**Pattern #3C** - Excellent for handling all miniature and micro-miniature parts. Shanks have tapered beveled edges with very sharp, honed points.

**Pattern #5** - Ideal for handling microscopic parts. Needle-like shape and sharpness.

**Pattern #7** - Excellent for handling all miniature and micro-miniature parts and components. Curved shanks have beveled edges and points are very sharp with a plain finish.

**Pattern A** - General utility tweezer used for assembly, inspection, and sorting. Thick shanks with flat edges enable the user to grip and hold the edge as well as the tip. Has plain points with wide blunt tips.

**Pattern AA** - Used for assembly, sorting, and soldering.

**Pattern SS** - Anti-acid, non-magnetic tweezer with fine, long narrow points.

**Order # 57-04000**

Item	Description	Length	Style	12+	6+	1+
J	Dumont II Stainless Steel	4½"	#3C	\$30.35	\$32.13	\$35.70
K	Dumont II Stainless Steel	4¼"	#5	\$28.05	\$29.70	\$33.00
L	Dumont II Stainless Steel	4½"	#7	\$34.00	\$36.00	\$40.00
M	Dumont Stainless Steel	4"	A	\$38.21	\$40.46	\$44.95
	Dumont II Stainless Steel	4¾"	AA	\$22.53	\$23.85	\$26.50
N	Dumont Carbon Steel	4½"	SS	\$31.45	\$33.30	\$37.00
P	Dumont Titanium	4¾"	#3	\$32.73	\$34.65	\$38.50
	Dumont Titanium	4¾"	AA	\$30.18	\$31.95	\$35.50



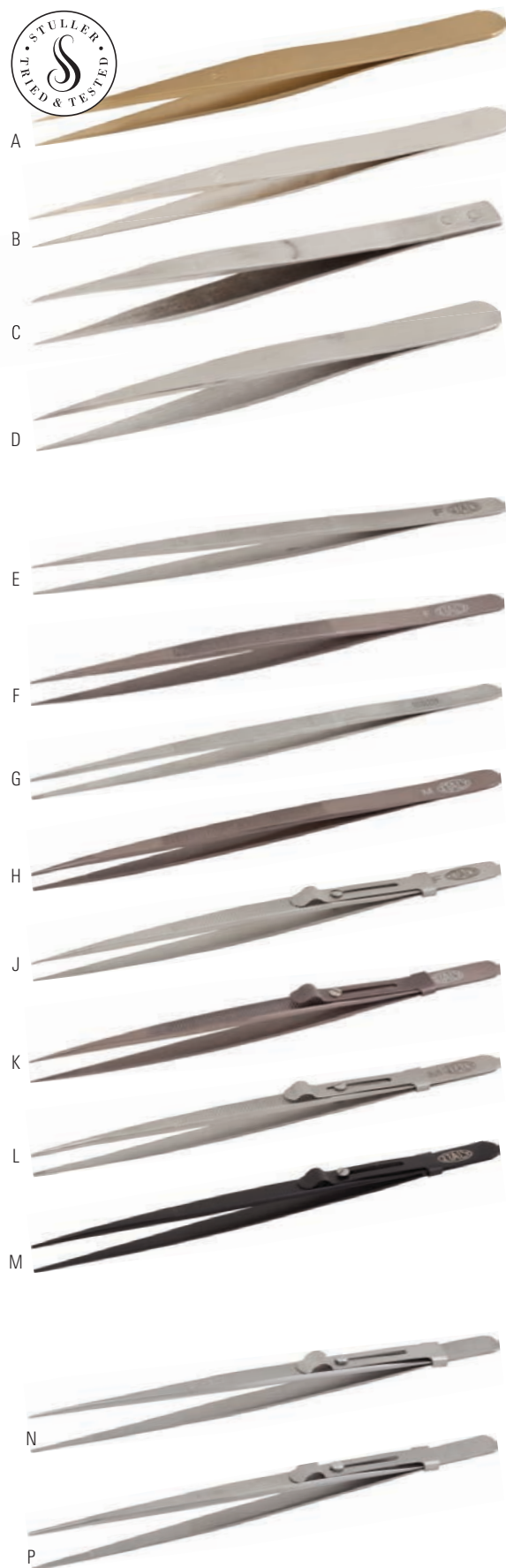

**PEER VIGOR PATTERN TWEEZERS**

Boley-style tweezers are used for general utility work. Shanks are tapered and have beveled edges.

**Pattern AM** - Heavy brass version excellent for handling parts that scratch easily.

**Pattern NN** - A short tweezer used for assembly, inspection, and sorting.

**Pattern RR** - Extra thick, heavy-duty tweezers.

**Pattern AA** - Use for assembly, inspection, sorting, soldering.

**Pattern MM** - Heavy-duty for assembly, sorting, and soldering.

**Order # 57-50350**

Item	Description	Length	Style	12+	6+	1+
A	Brass	5"	AM	\$25.50	\$27.00	\$30.00
B	Nickel-Plated	4½"	NN	\$16.41	\$17.37	\$19.30

ECONOMY

**Order # 57-50150**

C	Non-Magnetic	4¾"	AA	\$16.66	\$17.64	\$19.60
D	Anti-Magnetic	5"	MM	\$9.35	\$9.90	\$11.00

**SWISS DIAMOND TWEEZERS**

These high-quality, reasonably priced diamond tweezers are equal to the quality of more expensive brands. Available in black or matte stainless finish. Made in Italy.

**Order # 57-60520**

Item	Tip	Metal Type	Length	12+	6+	1+
E	Fine	Stainless Steel	6½"	\$11.48	\$12.15	\$13.50
F	Fine	Black Stainless Steel	6½"	\$11.48	\$12.15	\$13.50
G	Medium	Stainless Steel	6½"	\$10.41	\$11.03	\$12.25
H	Medium	Black Stainless Steel	6½"	\$11.48	\$12.15	\$13.50
J	Fine	Stainless Steel	6½"	\$11.48	\$12.15	\$13.50
K	Fine	Black Stainless Steel	6½"	\$11.48	\$12.15	\$13.50
L	Medium	Stainless Steel	6½"	\$10.41	\$11.03	\$12.25
M	Medium	Black Stainless Steel	6½"	\$11.48	\$12.15	\$13.50

**GENUINE SWISS DIAMOND TWEEZERS**

These self-locking tweezers are available in matte stainless steel finishes.

**Order # 57-60500**

Item	Tip	Metal Type	Length	12+	6+	1+
N	Fine	Stainless Steel	6"	\$39.06	\$41.36	\$45.95
P	Medium	Stainless Steel	6"	\$36.51	\$38.66	\$42.95

**RUSHIT INOX TWEEZERS**

These tweezers are made of a lightweight steel making working with them comfortable for long periods of time. The tweezers feature finely grooved tips to enable a good grip on the diamonds when picking and holding them.

**Order # 57-60400**

Item	Description	Length	12+	6+	1+
A	Extra-Fine Grip	6"	\$7.23	\$7.65	\$8.50
B	Fine Grip	6"	\$7.23	\$7.65	\$8.50
C	Medium-Fine Grip	6"	\$9.78	\$10.35	\$11.50
D	Large Grip	6"	\$9.78	\$10.35	\$11.50

**TITANIUM DIAMOND TWEEZERS**

These tweezers are superb quality and feature serrated points to allow the handling of stones with ease. They are very light and sensitive.

**Order # 57-62500**

Item	Tip	Length	12+	6+	1+
E	Medium	6"	\$50.41	\$53.37	\$59.30
F	Fine	6"	\$49.51	\$52.43	\$58.25

**DIAMOND TWEEZERS WITH SCOOP**

These diamond tweezers feature fine, serrated points and ribbed shanks.

Item	Order #	Description	Length	12+	6+	1+
G	<b>57-7660</b>	Tweezers with Scoop	7"	\$3.36	\$3.56	\$3.95

**SWISS PATTERN TWEEZERS WITH SATIN FINISH**

The satin soft touch provides a comfortable non-slip grip. These tweezers provide symmetry and balance for shaping, adjusting, and finishing.

**Order # 57-05700**

Item	Description	Length	Style	12+	6+	1+
H	Orange Grip Non-Slip	5"	#3	\$20.19	\$21.38	\$23.75
J	Orange Grip Non-Slip	5"	#5	\$24.44	\$25.88	\$28.75
K	Orange Grip Non-Slip	5"	#5A	\$24.44	\$25.88	\$28.75
L	Orange Grip Non-Slip	5"	#0	\$20.19	\$21.38	\$23.75
M	Orange Grip Non-Slip	5"	#2A	\$20.19	\$21.38	\$23.75







**ECONOMY BOLEY-STYLE TWEEZERS**

These general-utility tweezers are used for handling miniature parts and are heavier than style AA. Shanks are slightly longer, and the corner of the handle is rounded.

Order #	Description	Length	12+	6+	1+
57-5020	Boley-Style Tweezers	5"	\$3.40	\$3.60	\$4.00



**SMALL SOLDERING/UTILITY TWEEZERS**

Made of nickel-plated steel, these heavy-duty tweezers feature sharp and beveled edge points.

Order #	Description	Length	12+	6+	1+
57-7500	Soldering/Utility Tweezer	4¾"	\$4.59	\$4.86	\$5.40



**SCREW-HOLDING TWEEZERS**

Ideal for battery clamps and screws, the v-shaped notch makes it possible to hold the smallest screws for assembly.

Order #	Description	Length	12+	6+	1+
57-7525	Screw-Holding Tweezers	4¾"	\$9.35	\$9.90	\$11.00



**SPLIT RING TWEEZERS**

Easy-to-use tweezers open small to medium split rings. Just put the split ring under the claw and squeeze. They are made of stainless steel.

Order #	Description	Length	12+	6+	1+
57-7640	Split Ring Tweezers	4½"	\$4.21	\$4.46	\$4.95



**#D TWEEZERS END CUTTERS**

Transverse end cutter features a rounded cutting edge.

Order #	Metal Type	Length	12+	6+	1+
31-5039	Carbon Steel	3¾"	\$30.77	\$32.58	\$36.20



**LONG SOLDER/UTILITY TWEEZERS**

These heavy-duty tweezers are extra long with straight serrated points. Made of stainless steel.

Order #	Description	Length	12+	6+	1+
57-7505	Long Solder Tweezer	7"	\$4.89	\$5.18	\$5.75



**STONE/DIAMOND POCKET HOLDER**

Use to hold stones securely. Wire jaws contract into the body, and the plunger in the end opens wire jaws. This holder is small enough to fit in pocket.

Order #	Description	Length	1+
57-6015	Stone Pocket Holder	2"	\$5.60



**PRONGED HOLDING TWEEZERS**

Use for gripping and holding small objects such as stones and diamonds. A plunger in the handle opens the wire jaws that contract into the handle.

Order # 57-6016

Item	Description	Length	12+	6+	1+
A	3-Prong Holder	4¾"	\$4.76	\$5.04	\$5.60
B	4-Prong Holder	4¾"	\$4.68	\$4.95	\$5.50



**EASY LOOP GEM HOLDER**

The Easy Loop Gem Holder gently holds delicate stones the correct way for viewing. The two prongs hold the stone by its girdle to prevent scratching.

Order #	Description	Length	12+	6+	1+
57-6021	Easy Loop Gem Holder	4½"	\$4.38	\$4.64	\$5.15



**"SOFTIE" STONE TWEEZERS**

Never worry about damaging the edges of soft stones with our new "Softie" stone tweezers. They feature nylon attached to a fine stainless steel shank that gives this stone handling tool a nice tooth.

Order #	Description	Length	12+	6+	1+
57-7530	Softie Stone Tweezers	6½"	\$4.42	\$4.68	\$5.20



**PEARL-HOLDING TWEEZERS**

Tips are epoxy coated and will not damage pearls.

Order #	Description	Length	12+	6+	1+
57-6013	Holding Tweezers	5¾"	\$10.16	\$10.76	\$11.95



**JEWEL PICKERS**

The Jewel Picker is the ultimate tool for jewelry making, beading, stone setting, etc. This unique item was designed to replace sticky wax as a means to pick up stones to place them in a setting during the stone setting operation. The advantage of using this stick is that you can place your item with pin-point control. No more struggling with tweezers. When tip becomes dirty, just use steam, wash with warm water, or simply roll on adhesive tape to clean it up.

Order # 57-04500

Item	Description	12+	6+	1+
C	Small	\$8.20	\$8.69	\$9.65
D	Medium	\$8.20	\$8.69	\$9.65





**CROSS-LOCKING REVERSE-ACTION TWEEZERS**

Use to hold objects for soldering and can also be used in a variety of general applications. When pressure is applied to the handles, tips open. Once pressure is released from the handles, tips automatically close. Made of nickel-plated steel. Excellent heat sink when soldering.

Order # 57-76150

Item	Description	Length	12+	6+	1+
A	Blunt/Serrated Points	6½"	\$4.00	\$4.23	\$4.70
B	Sharp/Serrated Points	6½"	\$5.53	\$5.85	\$6.50
C	Sharp Points	4¾"	\$3.83	\$4.05	\$4.50



**FIVE-PIECE SOLDER/UTILITY TWEEZERS KIT**

Contains two self-closing general purpose tweezers and three utility/solder types in a deluxe pouch.

Order #	Description	12+	6+	1+
57-6038	Solder/Utility Kit	\$26.35	\$27.90	\$31.00



**FOUR-PIECE UTILITY TWEEZERS KIT**

This kit contains four popular tweezers in a handy PVC pouch. The set features the following styles: 4¾" general purpose, 6½" insulated cross-locking, 6½" bent nose, and 4½" cross-locking tweezers.

Order #	Description	12+	6+	1+
57-6037	Utility Tweezers Kit	\$9.31	\$9.86	\$10.95



**HALF-SHANK TWEEZERS**

These tweezers are designed specifically for the difficult task of holding half or quarter shanks in place while soldering with no fumbling or misalignment. Made of stainless steel with a third-hand base. Top arm of the tweezers swings out of the way when not in use.

Order # 57-76570

Item	Description	12+	6+	1+
D	Half-Shank Tweezers with Base	\$18.70	\$19.80	\$22.00
E	Half-Shank Tweezers	\$12.96	\$13.73	\$15.25

**THIRD HAND WITH TWEEZERS AND ROUND BASE**

Cross-locking tweezers are mounted on a heavy, non-tipping, round base. Ball-joint attachments located on the base allow work to be positioned at any angle. Free both hands by positioning pieces to be joined by solder or adhesive.

Order #	Description	Length	12+	6+	1+
54-0801	Third Hand with Tweezers	6½"	\$12.88	\$13.64	\$15.15



**SELF-LOCKING SOLDERING TWEEZERS**

Self-locking, soldering tweezers feature a fiber grip and heat-resistant handles.

Item	Order #	Description	Length	12+	6+	1+
A	57-7600	Straight Soldering Tweezers	6"	\$4.68	\$4.95	\$5.50
B	54-4560	Deluxe Third-Hand	6½"	\$15.73	\$16.65	\$18.50

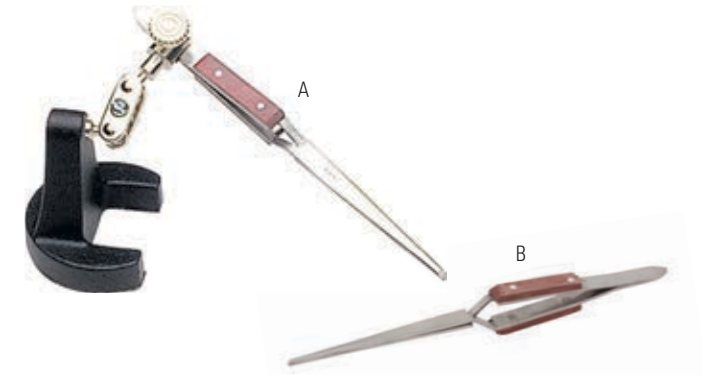

**TUNGSTEN-TIPPED TWEEZERS**

Tungsten-tipped tweezers are designed for platinum soldering. These cross locking, fiber-grip tweezers features replaceable tungsten-carbide tips.

Item	Order #	Description	Length	12+	6+	1+
C	57-6280	Tungsten-Tipped Tweezers	8¾"	\$40.08	\$42.44	\$47.15
D	57-6281	Replacement Tips Set of 2		\$8.29	\$8.78	\$9.75



**SELF-LOCKING SOLDERING TWEEZERS**

Self-locking, soldering tweezers feature a fiber grip and heat-resistant handles.

Order #	Description	Length	12+	6+	1+
57-7610	Curved Soldering Tweezers	6"	\$3.53	\$3.74	\$4.15



**TITANIUM TWEezer WITH FIBER GRIP**

Titanium cross-locking tweezers feature a fiber grip that will not contaminate platinum or other precious metals when soldering. These tweezers come to a fine point with finely serrated jaws for holding items securely.

Order #	Description	Length	12+	6+	1+
57-7631	Titanium Tweezers	6½"	\$27.67	\$29.30	\$32.55





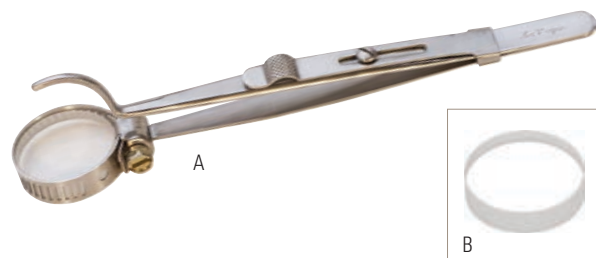

**LAVAQUE HEAD AND SHANK TWEEZERS**

The LaVaque locking tweezers allow the user to accurately align the ring shank with the head. The heat-resistant, replaceable glass allows the user to view all angles for perfect alignment. The glass is not intended for high heat, such as welding or platinum soldering.

**Order # 57-60010**

Item	Description	12+	6+	1+
A	Head and Shank Tweezers	\$23.76	\$25.16	\$27.95
B	Glass Lens for LaVaque Tweezers	\$6.16	\$6.53	\$7.25



**HEAD AND SHANK SOLDERING TWEEZERS**

Slide-locking, stainless steel tweezers with a curved, grooved tip and a flat, serrated base. Design holds setting and shank in position for easy soldering.

Order #	Description	Length	12+	6+	1+
<b>57-6000</b>	Soldering Tweezers	5½"	\$7.61	\$8.06	\$8.95



**RING SOLDERING TWEEZERS**

Holds ring from inside for easy soldering. Also holds two rings being soldered together as a set, which makes it ideal for wedding band sets.

Order #	Description	Length	12+	6+	1+
<b>48-2300</b>	Ring Soldering Tweezers	4¼"	\$4.68	\$4.95	\$5.50



**COPPER TONGS**

Use for pickling and acid solutions. Will not contaminate solutions or corrode.

**Order # 57-06900**

Item	Description	Length	12+	6+	1+
C	Curved Tip	8½"	\$6.76	\$7.16	\$7.95
D	Fishtail Tip	8½"	\$6.29	\$6.66	\$7.40



**ECONOMICAL STEAM TWEEZERS**

These are chrome-plated steam tweezers feature chemical resistant plastic coating on tips. Plastic coating may vary in color.

Order #	Description	Length	12+	6+	1+
<b>57-9200</b>	Steam Tweezers	11"	\$6.16	\$6.53	\$7.25



**COATED FORCEPS/STEAM TWEEZERS**

Use for handling items being steamed and/or cleaned in ultrasonics. Plastic coating on tips provide chemical resistance along with a firm grip for retrieving items without scratching. Made of nickel-plated steel. Plastic coating may vary in color.

**Order # 57-75100**

Item	Description	Length	12+	6+	1+
A	Cross-Locking	6½"	\$9.99	\$10.58	\$11.75
B	Straight	8"	\$9.35	\$9.90	\$11.00
C	Straight	10"	\$10.20	\$10.80	\$12.00



**BAMBOO TWEEZERS**

Tweezers made from bamboo have a gentle grip and will not damage small delicate objects. Bamboo tweezers are highly recommended for use in optical inspection and production environments. They have excellent insulation and are chemical-resistant.

**Order # 57-75170**

Item	Description	Length	12+	6+	1+
D	Small Pointed	6"	\$4.04	\$4.28	\$4.75
E	Large Pointed	9¾"	\$4.21	\$4.46	\$4.95
F	Large Flat Blunt	7"	\$4.89	\$5.18	\$5.75



**PLASTIC TWEEZERS**

Plastic tweezers work well for handling watch batteries or electronic parts for watches.

**Order # 57-75200**

Item	Color	Length	12+	6+	1+
G	White	4½"	\$0.77	\$0.81	\$0.90
H	Red	5"	\$1.23	\$1.31	\$1.45
J	Orange	7"	\$1.28	\$1.35	\$1.50



**HEMOSTAT FORCEPS**

Use as clamps when working with small articles. Made of stainless steel, these forceps feature box-joint construction and their serrated jaws to allow firm holding. Contains three position-locking device.

**Order # 46-45450**

Item	Description	Length	12+	6+	1+
K	Straight Forceps	5"	\$5.74	\$6.08	\$6.75
L	Curved Forceps	5"	\$5.53	\$5.85	\$6.50



**STEAMOSTAT**

Made of stainless steel, the Steamostat features PVC-covered tips for holding jewelry while steam cleaning.

Item	Order #	Description	Length	12+	6+	1+
M	<b>46-4555</b>	Steamostat	8"	\$9.78	\$10.35	\$11.50





# VIDEOS AND BOOKS



## JEWELRY MAKING

A. **62-4388 Gellars Blue Book Version 6.0.** This new Gellar's blue book set concentrates on jewelry repairs you'll learn how to set your price for repair prices and stay profitable with the sensitive customer. One-package set. **\$403.00**

B. **62-4590 Jewelry Handbook.** Practical guide to selecting the right jewelry for your lifestyle, budget, and body type. You'll learn the benefits and drawbacks of various setting. **\$22.70**

C. **62-4434 Jewelry Making** by Murray Bovin. Excellent book written in clean, easy-to-understand terms. Contains photographs and diagrams of fundamental processes and techniques such as enameling plating and etching. Softcover, 288-page, spiral-bound book. **\$32.50**

D. **62-4442 The Platinum Bench** by Jurgen J. Maerz. Step-by-step, this book features illustrated lessons on common platinum repair and fabrication projects as well as proper bench setup and casting. Learn how to size, clean, repair porosity, and much more. With more than 200 full-color photos to guide the way, this book will certainly earn a spot near every platinumsmith's bench. Softcover, 192-page book. **\$27.25**

E. **62-4438 JA Guide to Professional Fine Jewelry Craftsmanship.** This handy reference uses high-quality illustration to explain the most important components of jewelry artisanship. This book also helps identify causes and consequences of problems and sources of potential structural failures in jewelry design and fabrication. Softcover, 17 pages, spiral-bound. **\$89.90**

## BENCH JEWELERS

F. **62-4445 The Jeweler's Bench Reference.** by Harold O'Connor. Explains all types of jewelry-making techniques. Instructions on the care and use of equipment. Contains vital information about fabricating, soldering, stone setting, plating, and casting. Softcover, 67 pages, spiral-bound book. **\$18.35**

G. **62-4463 The Jeweler's Bench Book.** by Charles Lewton-Brain. With plentiful full-color illustrations, this book covers everything from the basics of bench design to ingenious tips for tool storage and arrangement. It also includes real-life tours of how renowned jewelers have set up their own bench areas. **\$39.75**

H. **62-4482 101 Bench Tips for Jewelers.** This books makes a jeweler's life more productive. The tips or trade secrets cover soldering, stone setting, and final polishing. This is an everyday bench source. Softcover, 120 pages. **\$44.30**

J. **62-4531 Profiting by Design.** Learn how to run a successful jewelry design business and have some fun along the way. A former gallery owner who also ran an award-winning design firm, Marlene Richey covers everything from identifying a target market and setting up shop to pricing, marketing, and selling your one-of-a-kind designs. **\$39.25**

K. **62-4620 The Jeweler's Studio Handbook.** This book guides you through the process of equipping your own jewelry studio and teaches you the techniques that will have you crafting one-of-a-kind metal jewelry in no time. **\$28.40**

## CASTING

A. **62-4432 Centrifugal Or Lost Wax Jewelry Casting** by Murray Bovin. This well-illustrated book is a must for anyone who does professional work. Covers mold making, waxing, forming, investing, burnout, and casting. Softcover, 144 pages, spiral-bound book. **\$24.25**

B. **62-4440 Practical Casting** by Tim McCreight. A handy bench reference that covers model making, spruing, investing, vacuum, and centrifugal and sand casting. It also covers unusual techniques such as steam and sling casting. Softcover, 122 pages, spiral-bound book. **\$19.55**

C. **62-4454 Jewelry Wax Modeling** by Adolfo Mattiello. This book takes you step-by-step through all aspects of design, layout, and carving with Matt™ tools. Contains clear instruction with more than 350 beautifully done black-and-white illustrations. 161 pages. **\$59.70**

D. **62-4479 Wax Modeling** by Adolfo Mattiello. This is an instructional book that shows how to get the most out of the Matt-Gun and extruding technique. Softcover, 113 pages. **\$27.85**

E. **21-0496 Wolf Precision Wax Carvers** by Kate Wolf. The author shares her 25 years of wax carving experience with tools specifically designed to revolutionize your wax carving process. Techniques are illustrated throughout this 22-page instruction booklet. Softcover. **\$13.45**

## METALS

F. **62-4433 Silversmithing and Art Metal** by Murray Bovin. Excellent reference guide for all who do metalsmithing. This book contains step-by-step text, detailed diagrams, and photographs of metal working, forming techniques, and the decorative process. Softcover, 184-page book. **\$25.80**

G. **62-4447 Moods in Wire** by Ed Sinclair. This book, with several hundred illustrations and 111 pages of explanation, provides a clear introduction to wire wrapping. Learn to make simple and fancy rings, bracelets, earrings, crosses, stick pins, and pendants. Softcover, 112 pages, spiral-bound book. **\$30.90**

H. **62-4471 The Complete Metalsmith** by Tim McCreight. An illustrated handbook describing everything from metals and their properties to tools and how to use them. Easy-to-follow index makes the answers easy to find. Softcover, 150 pages. **\$21.65**

J. **62-4488 Complete Metalsmith (Student Edition).** This book is perfect for hobbyists, students, and others who are just getting started in metalworking. It covers the basics, including a section on metal clay. 160 pages. **\$17.35**

K. **62-4488 Complete Metalsmith (Professional Edition).** This book is perfect for serious artists. It builds on what is learned in the student edition by covering the same material in greater depth and expanded information. 312 pages. **\$34.80**

L. **21-0541 Techniques of Jewelry Illustration and Color Rendering** by Adolfo Mattiello. This book provides a splendid array of methods and styles of jewelry illustrations. It includes a method of quick sketching based on the use of templates to guide the beginner as well as the advanced student in the production of precise renderings. Hardcover, 150 pages. **\$45.35**



A

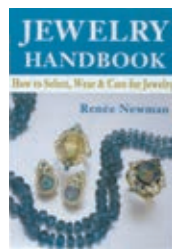

B



C



D



E

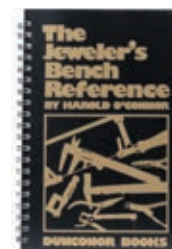

F



G



H

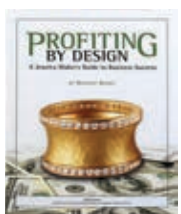

J



K



A

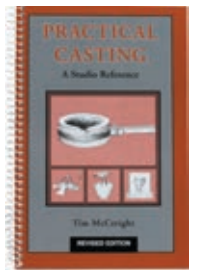

B



C

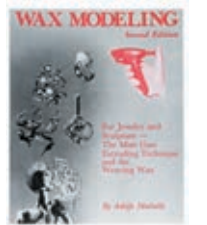

D



E



F



G



H



J



K



L



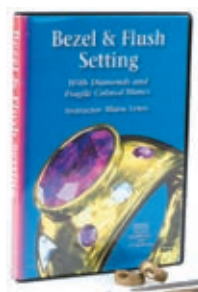
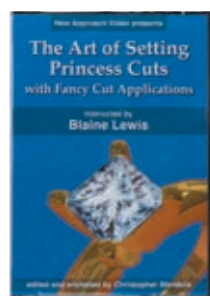
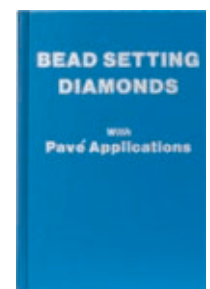
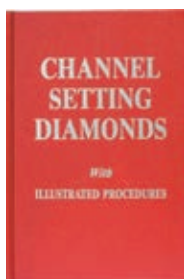
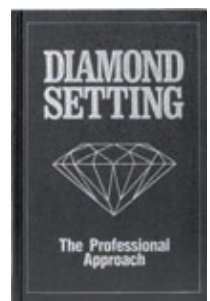
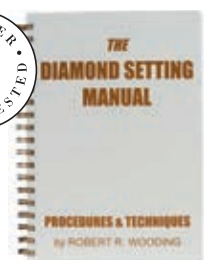

**SETTING**

**A. 62-4427 *The Diamond Setting Manual*** by Robert R. Wooding. This manual is an incredible step-by-step source for common diamond setting procedures. It is intended for experienced professional diamond setters, as well as students under the supervision of a qualified, diamond setting instructor. Softcover, 223 pages, spiral-bound book. **\$41.20**

**B. 62-4421 *Diamond Setting*** by Robert R. Wooding. The most complete, diamond setting book available. Teaches basic and advanced diamond setting with complete step-by-step details for a variety of procedures. Contains illustrated line drawings of necessary tool preparation, techniques, and procedures. Alternative methods to setting diamonds are also included. Hardcover, 178 pages. **\$30.90**

**C. 62-4423 *Channel Setting Diamonds*** by Robert R. Wooding. The most advanced, instructional book for channel-setting diamonds. Book is divided into two general sections. Topics covered include: inspection, layout, cutting channels, cutting bearings, inlaid channels, finishing, basic closed channel, basic open channel, curved channels, tapered channels, angular channels, and securing diamonds. Hardcover, 136 pages. **\$32.50**

**D. 62-4422 *Bead-Setting Diamonds with Pavé Applications*** by Robert R. Wooding. Step-by-step instruction book provides more than 250 close-up photographs of bead-setting tasks, supported by detailed line drawings where necessary, to clarify each phase of bead setting. Tool preparation presented in-depth is required to raise beads from plate metal and bright cutting. Hardcover, 192 pages. **\$30.90**

**E. 62-4391 *Diamond Setting Bead & Bright-Cut***. This video focuses on bead and bright-cut diamond setting. Learn how to bead-set stones and set multiple small stones in an easy-to follow sequence from drilling and sizing the stone seats to raising each bead through final bright cuts. DVD, Running time: 2 hours. **\$30.90**

**F. 62-4395 *The Art of Setting Princess Cuts***. Hundreds of tips for the stone setter to set princess-cut and fancy-cut stones in standard and V-prong settings. DVD, two hours, 30 minutes. **\$183.45**

**G. 62-4389 *Bezel & Flush Setting***. by Blaine Lewis. This two DVD set guides you step by step in bezel and flush setting diamonds and colored stones. Comes with two practice mountings, two sets of practice stones, one GRS® hard steel point, burnisher, and templates. DVD, Running time: 150 minutes (total). **\$183.45**

**SETTING DVDS**

Turn your DVD player into your private instructor. These DVDs enable you to learn and improve your craft by watching, listening, and allowing you to review each step as needed.

Item	Order #	Description	1+
H	62-4540	Basic Setting	\$25.80
J	62-4541	Oval Setting	\$25.80
K	62-4542	Pear Setting	\$25.80
L	62-4543	Marquise Setting	\$25.80
M	62-4544	Princess-Cut Setting	\$25.80
N	62-4545	Emerald-Cut Setting	\$25.80
P	62-4546	Bezel Setting	\$25.80

**ENGRAVING**

**A. 62-4393 *Engraving Methods & Techniques***. This two-DVD set puts years of engraving experience into a four-hour video presentation. Three of the world's most popular engraving methods are shown: hand engraving, chasing hammer engraving, and power-assisted hand engraving. DVD: Running time: four hours. **\$46.00**

**B. 62-4453 *The Jewelry Engravers Manual***. This book concentrates on jewelry engraving with special emphasis on lettering, monogramming, and ring engraving. Use of tools and proper work techniques are clearly described. Softcover, 143 pages. **\$9.95**

**C. 62-4387 *Up-Close with Sam Alfano***. Eight Special Stone Setting & Engraving demos by the master engraver and craftsman, Sam Alfano. Fast-paced, fun, and informative. Opens your eyes and mind to different stone setting and engraving techniques. He uses GRS equipment with traditional setting tools and burs while demonstrating these techniques. DVD, Running Time: 60 Minutes. **\$41.90**

**D. 62-4397 *Successful Jewelry Engraving***. Sam Alfano presents this instructional video, designed to get you up to speed in the jewelry engraving field quickly. Learn basic to advanced techniques that local stores and manufacturers demand. Learn high-end techniques of relief engraving, sculpting, bright-cut leaf borders, and more. DVD, Running Time: 120 minutes. **\$54.65**

**E. 62-4459 *The Expert's Guide to Graver Sharpening***. This DVD is sponsored by Sam Alfano. He will teach the professional jeweler with step-by-step close-ups of how to sharpen square, flat, and round gravers. Get the tips and tricks to engraving. DVD, Running Time: 60 Minutes **\$51.50**

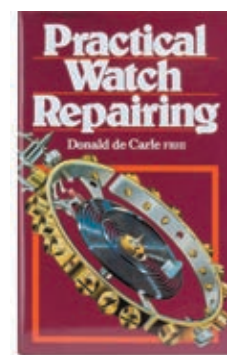

**CLOCK AND WATCH REPAIR**

**F. 62-4511 *Practical Clock Repairing***. by Donald de Carle, FBHI. Deals with the usual faults likely to develop in each type of movement in general use, from grandfather to alarm clocks. All tools and equipment are described and illustrated, along with information on proper use. With 400 illustrations. Hardcover, 240 pages. **\$53.75**

**G. 62-4514 *Practical Watch Repairing***. by Donald de Carle, FBHI. This book contains 550 illustrations describing the theories and processes of repairing and adjusting the modern watch precisely and with meticulous detail. Hardcover, 299 pages. **\$18.35**



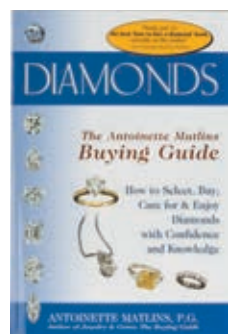

A

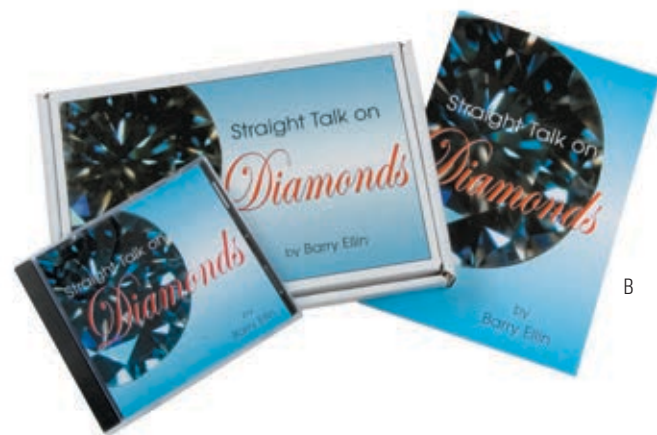

B

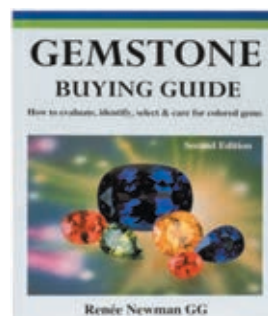

C

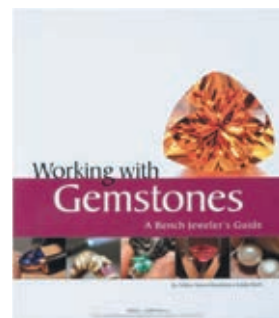

D

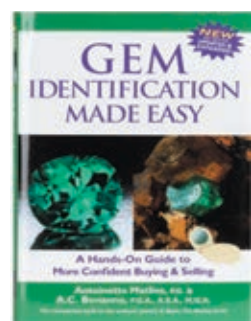

E

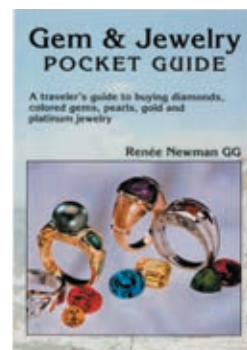

F

## DIAMONDS

A. **62-4476 *Diamond Buying Guide*** by Antoinette Matlins. This comprehensive guide, from diamond expert and best-selling author Antoinette Matlins, is the "unofficial bible" for all diamond buyers who want to get the most for their money. 220 pages.

**\$20.10**

B. **62-4455 *Straight Talk on Diamonds*** by Barry Ellin. This is a short course on diamonds, explaining diamond quality in a clear and concise manner. The book and CD set stresses how the different quality factors affect value. The book contains dozens of pictures and diagrams that are easy to follow. Perfect for salespeople at jewelry stores or anyone new to the field of diamonds.

**\$88.65**

## GEMSTONES

C. **62-4465 *Gemstone Buying Guide*** by Renée Newman GG. Written for both consumers and professionals in an easy-to-read format, this guide features more than 150 colored photos. A comprehensive guide to evaluating, identifying, selecting, and caring for a variety of colored gemstones. 148 pages.

**\$24.75**

D. **62-4497 *Working with Gemstones*** by Arthur Skuratowicz and Julie Nash. Sharing their insights on how to work on gem-set jewelry, this book discusses the various gemstones that react to heat and pressure, mountings modifications, and what tools to use for the different characteristics of the gemstones being mounted. Softcover.

**\$37.65**

E. **62-4467 *Gem Identification Made Easy*** by Antoinette L. Matlins & A.C. Bonanno. This book explains in nontechnical terms how to use pocket, portable, and laboratory instruments to identify diamonds and colored gems. It also shows how to separate real gems from imitations and look-a-likes. Hardcover, 270 pages.

**\$38.10**

F. **62-4464 *Gem & Jewelry Pocket Guide*** by Renée Newman, G.G. A traveler's guide to buying diamonds, colored gems, pearls, gold, and platinum jewelry. It can be used as a consumer guide, sales training tool, or a reference for jewelry professionals. 160 pages.

**\$14.65**

## PEARLS

A. **62-4466 *Pearl Buying Guide*** by Renée Newman GG. This indispensable guide has details on judging pearl quality and value. Author Renée Newman is a gemologist with broad experience in pricing, evaluating, and selling gemstones and jewelry. 156 pages.

**\$26.00**

B. **62-4478 *The Pearl Book*** by Antoinette Matlins. This revised and updated third edition is a comprehensive, authoritative guide that tells readers everything they need to know about pearls, to fully understand them and appreciate them, and to avoid any unexpected and costly disappointments now and in future generations. 232 pages.

**\$24.75**

C. **62-4605 *Making Designer Freshwater Pearl Jewelry Book***. Pearls are not only available in classic round and glistening white form but also in a range of exotic and beautiful colors and shapes. The popularity of the pearl in fashion has never been greater. This is the first jewelry-making book focused on pearls no longer only seen at church and weddings. The projects range from casual design to bohemian and classic styles, to unique signature pieces in contemporary styles.

**\$28.40**

D. **62-4608 *Pearls***. An indispensable scientifically grounded reference work about pearls that resembles an exciting novel. The book covers the characteristics of pearls and cultured pearls. All pearl treatments and modern analysis methods are explained, including microscopes, UV lamps, x-ray devices, and others. This standard book offers a fantastic insight into five millennia of pearl history.

**\$160.70**

## JEWELRY

E. **62-5100 *Jewelry & Gems: The Buying Guide*** by Antoinette Matlins, P.G. This easy-to-read guide to buying diamonds, pearls, colored gemstones, gold, and jewelry will give every buyer the confidence and knowledge to do their job well. There is always a thrill with buying a one-of-a-kind gemstone, diamond, or piece of jewelry. The author makes it easy for any professional buyer. Hardcover, 352 pages.

**\$22.70**

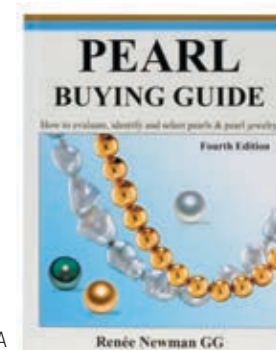

A

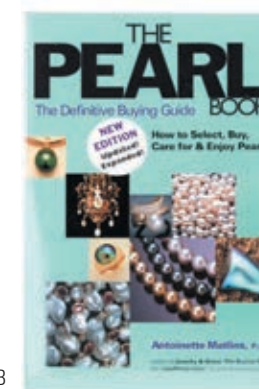

B



C



D



E



# WATCH TOOLS AND SUPPLIES



### BECO TECHNIC TOGGLE PRESS

Beco Technic Toggle Press is a professional device suitable for closing watch cases and setting crystals. Due to the zero-point-fixing, it prevents the user from breaking cases or glasses. Please order dies separately.

Order # 59-0760

Description	12+	6+	1+
Toggle Press	\$262.65	\$278.10	\$309.00
Adapter for Toggle Press	\$15.55	\$16.22	\$16.90



### BECO WINDING PRESS

Beco Technic PROFI PRESS winding press with snap-on dies

Order # 59-0761

Description	12+	6+	1+
Winding Press	\$118.15	\$125.10	\$139.00
Platform Adapter for Winding Press	\$26.17	\$27.31	\$28.45

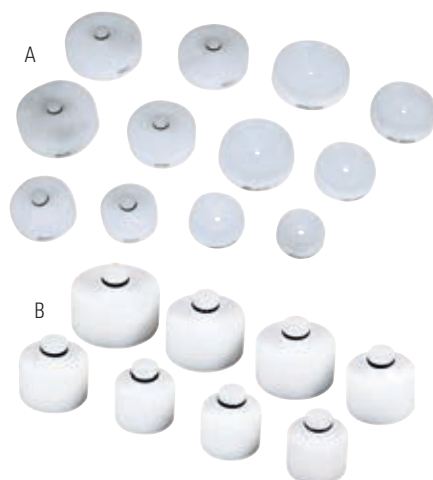

### DIE SETS

A. Expanding Set with six double concave dies Ø 27,5-55 mm with inside thread M6 and six plane dies Ø 35-55 mm with shaft 10 mm for winding press 59-0761 (support 59-0761 needed) and toggle press 59-0760 (support 59-0760 needed)

B. Standard set of eight dies with O-Ring (4 x plane, 4 x concave, Ø 22, 26, 30, 34 mm) for toggle press (59-0760)

Item	Order #	Description	12+	6+	1+
A	59-0762	Expanding Set with 6 double concave dies	\$70.85	\$75.02	\$83.35
B	59-0763	Standard set of 8 dies with O-Ring	\$41.14	\$43.56	\$48.40

### A. BECO AQUA FIX WATCH CASE OPENER

This vice is used for opening and closing waterproof watch screw cases, including the following accessories:

- Two adjustable jaws for watch cases with slots
- Two adjustable jaws for watch cases with straight edges
- Two adjustable jaws for watch cases with holes
- Two adjustable jaws for use with Rolex® Oyster® watch cases
- One holder for jaws with precision fixing
- One case holder with four changeable jaws

### B. BECO TECHNIC DIE SET

Beco Technic set of 24 pieces Delrin® dies with brass thread M6

Item	Order #	Description	12+	6+	1+
A	59-0781	Watch Case Opener	\$269.88	\$285.75	\$317.50
B	59-0764	Die Set of 24	\$162.27	\$171.81	\$190.90

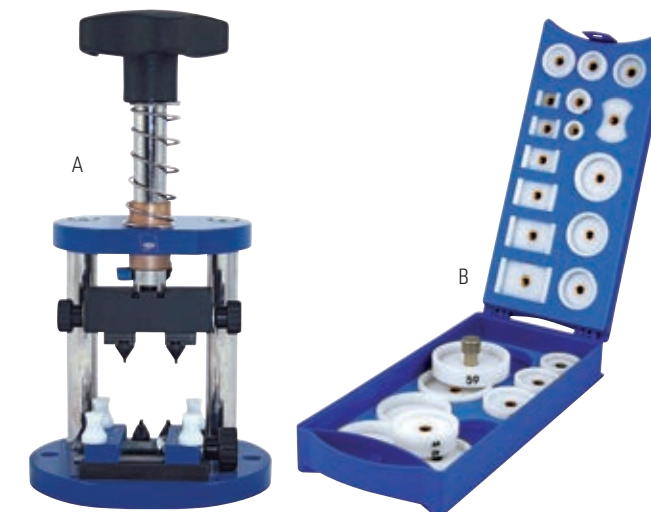

Rolex® and Oyster® are registered trademarks of Rolex Watch USA, Inc. The products offered herein are not manufactured, authorized or endorsed by Rolex Watch USA, Inc.

### DOUBLE SCREW CASE PRESS WITH 24 DIES

This high-quality case press will help you with all of your watch repair needs. Re-attach the watch backs without worrying about breaking the crystal. Choose from 24 nylon dies to match any watch back.

Order #	Description	1+
59-0793	Watch Case Press	\$279.95



### LG OPENALL WATERPROOF CASE WATCH SET

Specially designed for use in opening Rolex® Oyster® cases, the six tempered rings accurately interlock with the edges on genuine Rolex cases. Sturdy cast frame fits any bench vise. Built-in, adjustable case holder fits all size watches. Ring sizes are 18.5, 20.5, 22.5, 26.5, 28.3, 29.5 millimeters. Made in the USA.

Item	Order #	Description	Gauge Size	12+	6+	1+
C	59-0650	Case Wrench Set	18.5-29.5 mm	\$65.03	\$68.85	\$76.50

### REPLACEMENTS

Order # 59-06510

D	LG Openall Base	\$13.60	\$14.40	\$16.00	
E	Replacement Rings	18.5 mm	\$8.46	\$8.96	\$9.95
F	Replacement Rings	20.2 mm	\$8.46	\$8.96	\$9.95
G	Replacement Rings	22.5 mm	\$8.46	\$8.96	\$9.95
H	Replacement Rings	26.5 mm	\$8.46	\$8.96	\$9.95
J	Replacement Rings	28.3 mm	\$8.46	\$8.96	\$9.95
K	Replacement Rings	29.5 mm	\$8.46	\$8.96	\$9.95

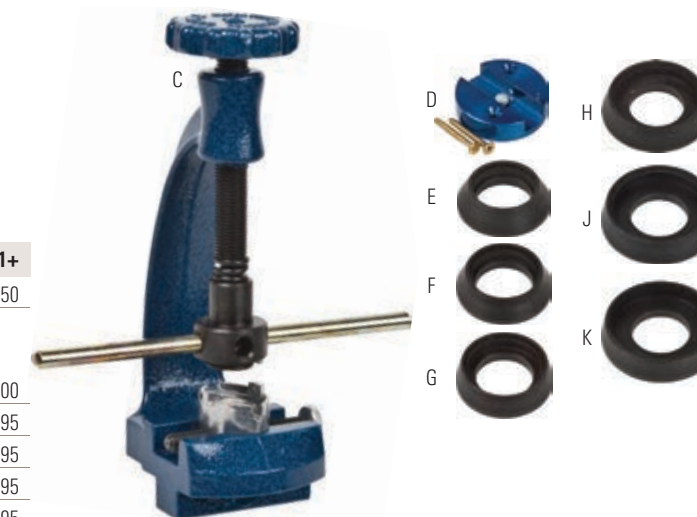

Rolex® and Oyster® are registered trademarks of Rolex Watch USA, Inc. The products offered herein are not manufactured, authorized or endorsed by Rolex Watch USA, Inc.





**CASE PRESS WITH METAL DIES**

Combination case closer/crystal press features 14 reversible, turned aluminum dies with 28 sizes. Dies screw onto the upper and lower parts so that they can be inverted for case closing or crystal fitting. Cast metal body with angled leverage arm for proper closure.

Item	Order #	Description	12+	6+	1+
A	59-0797	Combination Case Press	\$38.34	\$40.59	\$45.10
B	59-0794	Extra-Large Round Aluminum (set of 6)	\$33.49	\$35.46	\$39.40



**BERGEON WRENCH JAXA - SWISS MADE**

The new Bergeon wrench Jaxa is especially designed to open large watch cases. Its ergonomic shape ensures comfortable handling during the work process.

- Suitable for 18mm up to 62 mm
- 4 pieces of insets for both polygonal and grooved cases as well as for cases with holes or notches
- Including a flexible ruler
- Delivered in practical plastic box

Order #	Description	12+	6+	1+
59-0780	Bergeon Wrench Jaxa	\$162.35	\$171.90	\$191.00



**CASE PRESS WITH NYLON DIES**

C. Made of cast metal to ensure strength, this case press contains an assortment of nylon dies that will not scratch or mar crystals. Dies snap on and off easily. Configuration is face down which allows the repair person to see the back being closed. Includes 14 dies (7 sizes: 18, 20, 24, 28, 30, 32, and 36 mm).



D. Larger snap-on nylon dies to fit our 59-0795:132008:T. This set is designed for larger oversized watches that are very popular and most have snap-on case backs. There are a total of six pieces three flat on both sides 35 40 and 45mm and three double sided concave that are 40/42.5 45/47.5 and 50/52.5mm concave.



E. 12 assorted nylon dies fit all size watches and are used to close snap-on watch backs, install bezel rings, and make battery changes.

Item	Order #	Description	12+	6+	1+
C	59-0795	Case Press	\$24.65	\$26.10	\$29.00
D	59-0790	Large Nylon Dies	\$16.07	\$17.01	\$18.90
E	59-0798	Nylon Round Dies (set of 12)	\$9.90	\$10.49	\$11.65

**LG MASTER CASE OPENER**

Opens all sizes and shapes of waterproof cases. Gets a tight, non-slip grip that will not scratch or mar. Sold with four sets of pins for case backs with notches, holes, knurled, or polygon. Made in the USA.

Item	Order #	Description	12+	6+	1+
A	59-0550	Case Opener	\$74.50	\$78.89	\$87.65
B	59-0555	Replacement Pins	\$28.35	\$30.02	\$33.35



**WATCH CASE OPENER**

High-quality waterproof watch case wrench is a new, larger style of watch case back openers. (max opening dimensions - 54.5 mm)

Order #	Description	1+
59-0565	Watch Case Opener with Pins	\$27.50



**BERGEON CASE OPENER SET FOR USE WITH ROLEX® OYSTER® WATCHES**

For use in opening Rolex Oyster® waterproof watches, this unit comes with six milled rings (18.5, 20.2, 22.5, 26.5, 28.3, and 29.5mm). Made in Switzerland.

Order #	Description	1+
59-0645	Watch Case Opener	\$185.00

*Rolex® and Oyster® are registered trademarks of Rolex Watch USA, Inc. The products offered herein are not manufactured, authorized or endorsed by Rolex Watch USA, Inc.*

**WATCH CASE OPENER SET**

Watch case opener in wooden box, complete with set of pins. (max opening dimensions - 36.5 mm)

Order #	Description	1+
59-0562	Watch Case Opener with Pins	\$11.00
59-0561	12-Piece Replacement Pins	\$1.80





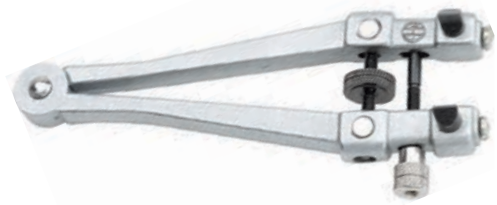

**STAINLESS STEEL CASE OPENER V-STYLE**  
This universal watch case opener will remove various types of screw-on case backs. (max opening dimensions - 35.5 mm)

Order #	Description	12+	6+	1+
59-0563	V-Style Case Opener	\$28.26	\$29.93	\$33.25



**STAINLESS STEEL CASE OPENER**  
This new opener is made for screw-back watch cases. The 4½" handle provides enough leverage to open those stubborn watch case backs. (max opening dimensions - 57 mm)

Order #	Description	12+	6+	1+
59-0564	Case Opener	\$18.91	\$20.03	\$22.25



**POCKET-SIZED CASE OPENER**  
This wrench is used for opening waterproof cases. It is compact and convenient with tempered pins and an adjusting wheel.

Order #	Description	W x H x D	12+	6+	1+
59-0487	Case Opener	2½" x ½" x 1½"	\$3.91	\$4.14	\$4.60



**WATCH CASE-CLOSING PLIERS**  
Provides safe and dependable closing of watch cases. Jaws close parallel with circular, rubber-padded, hinged discs.

Item	Order #	Description	Length	12+	6+	1+
A	46-8050	Closing Pliers	7½"	\$11.22	\$11.88	\$13.20
B	46-8055	Set of Replacement Pads		\$1.89	\$1.97	\$2.05



**CASE OPENER**  
This suction-type case opener is great for lifting the back off of screw-back and waterproof watch cases after back has been loosened. Rubber end does not scratch cases or crystals. Made in Switzerland.

Order #	Description	12+	6+	1+
59-0472	Case Opener	\$3.83	\$4.05	\$4.50



**CASE OPENER TOOL**  
The case opener tool is used for removing snap-on case backs. This case opener allows a precise adjustment with an anti-skid case holder mounted on a spring. It comes with two sets of hardened steel blades in two-millimeter and four-millimeter sizes and one Delrin® die.

Order #	Description	12+	6+	1+
59-0903	Case Opener	\$142.12	\$150.48	\$167.20

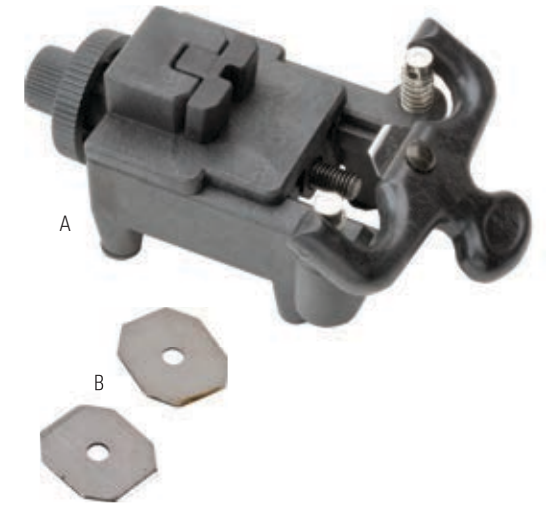

**SNAP-BACK CASE OPENER**  
Snap-Back case opener opens watch cases quickly and easily. The blade is reversible for multiple uses.

Item	Order #	Description	12+	6+	1+
A	59-0482	Snap-Back Case Opener	\$86.19	\$91.26	\$101.40
B	59-0489	Replacement Blade for 59-0482	\$30.68	\$32.02	\$33.35



**SNAPPY CASE OPENER**  
Designed to make opening watch cases easier. Just position the point between the case back and the case, then slowly push. The blade pops under the back and the watch case easily opens.

Order #	Description	12+	6+	1+
59-0473	Snappy Case Opener	\$9.27	\$9.81	\$10.90



**NARROW END WATCH CASE OPENER**  
Ideal for smaller watches, this compact, comfortable-to-hold tool quickly and smoothly opens press-fit and snap-on case backs. Press the four-millimeter blade into the notch; then lift to pop the back off.

Order #	Description	12+	6+	1+
59-0412	Watch Case Opener	\$7.61	\$8.06	\$8.95



**WATCH CASE OPENER**  
This easy-to-use watch case opener works well for snap-type case backs.

Order #	Description	12+	6+	1+
59-0411	Watch Case Opener	\$4.89	\$5.18	\$5.75



**WATCH CASE KNIFE**  
Easy-to-use watch case opener for snap-type case backs.

Order #	Description	Length	12+	6+	1+
59-0475	Watch Case Opener	3½"	\$3.74	\$3.96	\$4.40

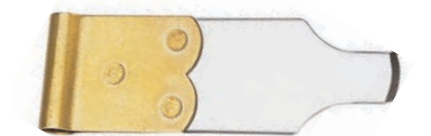

**POCKET-SIZED CASE OPENER**  
This is a handy, pocket-sized case opener.

Order #	Description	W x L	12+	6+	1+
59-0410	Case Opener	2¾" x ¾"	\$3.87	\$4.10	\$4.55



**CASE KNIFE**

Sturdy German-made case knife with a comfortable red, cushion grip PVC handle. The blade has a single bevel edge for removing case backs. Knife is made from well-tempered tool steel.

Order #	Description	Length	12+	6+	1+
59-0476	Case Knife	4½"	\$15.34	\$16.25	\$18.05



**BLADE-STYLE WATCHCASE OPENER**

Use for opening friction-fit cases. The universally popular shape gives the watchmaker the small handle necessary to obtain the proper grip when trying to open watch case backs. Blade is made of tempered steel set in a hardwood, non-roll handle.

Order #	Description	Length	12+	6+	1+
59-0470	Watch Case Opener	4½"	\$4.55	\$4.82	\$5.35

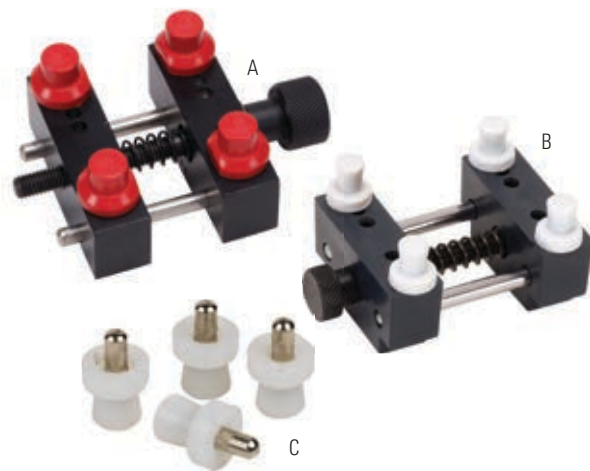

**CASE OPENERS**

These case openers accept medium and large watches that are found in today's market. It will securely hold watch cases without marring or scratching the watch case.

Item	Order #	Description	12+	6+	1+
A	64-4080	Large Case Opener	\$14.03	\$14.85	\$16.50
B	64-4077	Medium Case Opener	\$6.46	\$6.84	\$7.60
C	64-4078	Replacement Pins (4)	\$5.70	\$6.03	\$6.70

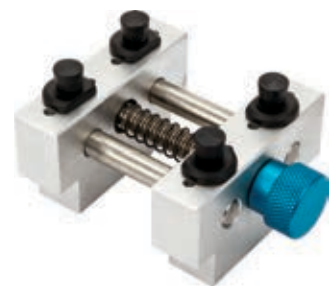

**WATCH HOLDER**

Order #	Description	12+	6+	1+
64-4076	Watch Holder	\$17.76	\$18.80	\$20.89



**WOODEN CASE VISE**

Will securely hold and not mar any waterproof case while the back is being unscrewed.

Order #	Description	12+	6+	1+
64-4079	Wooden Case Vise	\$5.02	\$5.31	\$5.90

**TWO WAY HOLDER**

Each side has two sets of cutouts for different size movements.

Item	Order #	Description	12+	6+	1+
A	59-0961	2-Way Holder	\$25.25	\$26.73	\$29.70
B	64-4000	2-Way Movement Holder	-	-	\$36.35



**A. BECO CASING CUSHION 70 MM**

VOH casing cushion with black Stamoid, Ø 70 mm

**B. BECO CASING CUSHION 55 MM**

VOH casing cushion with black Stamoid, Ø 50 mm

**Order # 59-0779**

Item	Description	Diameter	12+	6+	1+
C	Beco Casing Cushion	70mm	\$17.64	\$18.68	\$20.75
D	Beco Casing Cushion	50mm	\$14.45	\$15.30	\$17.00

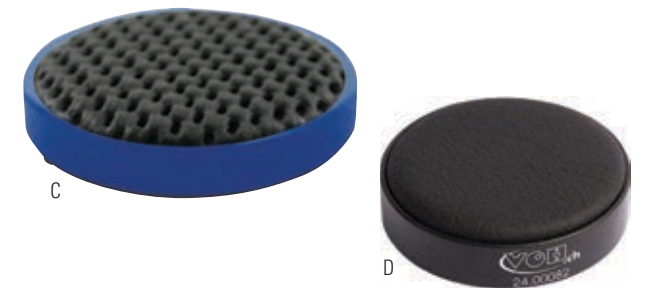

**BERGEON CASE CUSHION**

Held together firmly with a sturdy metal ring, this vinyl pad will hold crystals comfortably without scratching. Ideal for supporting watches while opening or closing cases.

Order #	Description	Diameter	12+	6+	1+
64-5102	Case Cushion	2"	\$49.81	\$52.74	\$58.60



**DELUXE EVEREADY® BATTERY TOOL KIT**

Contains the tools you need to change a battery in a convenient, faux-leather pouch. Has a zipper and elastic bands to keep tools securely in place. Shipped with a complete list of tools for easy replacement.

Order #	Description	1+
59-2500	Battery Tool Kit	\$31.15



**WATCH TOOL KIT**

This watch kit is specifically designed for watch battery replacement of all brand name watches. The tools included will allow you to open the watch back, remove the old watch battery, safely handle all components, replace your watch batteries, size or replace your watchband, replace or adjust watchband clasp, or remove watchband links.

- Yellow case opener
- Aluminum spring bar tool
- Watchmakers hammer
- Blue band opener
- Bracelet holding block
- Pocket case opener
- 1.6mm screwdriver
- Case holder
- 2.0mm screwdriver
- Multifunction watchband remover
- Plastic tweezers

Order #	Description	1+
59-2600	Watch Tool Kit	\$40.80



Find added video content on [Stuller.com/VideoCenter](http://Stuller.com/VideoCenter).





**WATCH/BRACELET CUTTING TOOL**

This bracelet cutting tool is used for pressing out and screwing out metal pins of watch bracelets

Order #	Description	12+	6+	1+
59-0772	Cutting Tool	\$100.51	\$106.43	\$118.25
59-0772	Replacement Pins	\$12.83	\$13.39	\$13.95



**MULTIPURPOSE WATCHBAND PRESS**

Complete system for removing screw-type case bars, band pins, and friction link pins. Made in Switzerland. Includes

- One screwdriver with blade
- Nylon case protector
- Pin holder
- Band holder with eight slots (2.5mm, 2.75mm, 3.0mm, 3.25mm, 3.5mm, 4.0mm, 4.5mm, 5.0mm)
- Set of seven pins (0.4mm, 0.6mm, 0.7mm, 0.8mm, 1.0mm, 1.5mm, 2.0mm)

Item	Order #	Description	12+	6+	1+
A	59-0805	Watch Strap Press	\$22.10	\$23.40	\$26.00
B	59-0806	Replacement Pins (6 sizes)	\$15.05	\$15.93	\$17.70



**WATCHBAND TOOL KIT**

This well-made system is used for removing and fitting pins. Constructed with a heavy, plastic band holder and a sturdy wooden base (90 x 80 mm) 51/8 x 31/4". Includes band holder with eight slots, pin holder with knurled handle (5 mm), a set of six pins (0.4mm, 0.6mm, 0.8mm, 1.0mm, 1.5mm, 2.0mm), and a wooden base. Made in Switzerland.

Order #	Description	12+	6+	1+
59-0804	Watch Band Tool Kit	\$27.16	\$28.76	\$31.95



**DELUXE WATCHBAND TOOL SET**

This is an excellent tool for all size watchbands and includes extra pins (0.8mm and 1.0mm) with hand tools.

Order # 59-0809

Item	Description	12+	6+	1+
C	Watch Band Tool	\$23.42	\$24.80	\$27.55
	1.0mm Replacement Pin	-	\$1.94	\$2.15
	0.8mm Replacement Pin	-	\$1.94	\$2.15

**PIN REMOVING KIT**

Practical and economical kit works well for removing friction pins from watch bracelets. Hammer included.

Item	Order #	Description	12+	6+	1+
D	59-0402	Pin Removing Kit	\$16.15	\$17.10	\$19.00

**REPLACEMENT PIN PUNCH**

Replacement pins for 59-0402 and 59-0809. Can be used with both kits.

Item	Order #	Description	Pin Size	12+	6+	1+
E	59-0403	Watch Band Pin Remover Tip	.80mm	\$0.85	\$0.90	\$1.00
F	59-0404	Watch Band Pin Remover Tip	1.0mm	\$0.85	\$0.90	\$1.00
G	59-0405	Replacement Pin Punch	.80mm	\$4.17	\$4.41	\$4.90
H	59-0406	Replacement Pin Punch	1.0mm	\$4.17	\$4.41	\$4.90



**WOOD BRACELET HOLDER**

The Eurotool® bracelet holder is made from the perfect medium because wood will not scratch precious metals. Holding a watch bracelet while removing pins or screws is difficult, but it becomes routine with this tool. Slits of various widths allow the user to handle any thickness of bracelet, and a hole in the middle of the holder allows one to push out bracelet pins. This is a must for every bench.

Order #	Description	12+	6+	1+
59-0400	Bracelet Holder	\$5.06	\$5.36	\$5.95



**LINK PIN REMOVER**

Use to remove pins from metal link bands. Made of Keltec II glass-filled nylon. Includes two extra spacers to accommodate all bracelet sizes. Pusher pin is made of hardened tool steel. Will not scratch or mar gold or silver. Four pins included: two 1.0mm, one 0.65mm, and one 0.85mm.

Item	Order #	Description	12+	6+	1+
A	59-0800	Link Pin Remover	\$11.01	\$11.66	\$12.95
B	59-0813	Replacement Pins	\$3.23	\$3.42	\$3.80

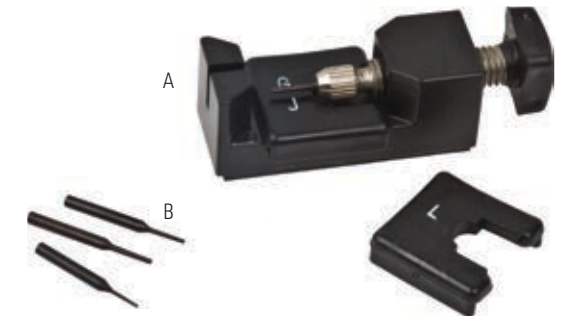

**DELUXE BRACELET PIN REMOVING SET**

Use this handy tool to remove tough watchband pins.

Item	Order #	Description	12+	6+	1+
C	64-5008	Bracelet Pin Remover	\$18.91	\$20.03	\$22.25
D	64-5009	Replacement Pin	\$1.96	\$2.07	\$2.30



**MULTIFUNCTION WATCH TOOL**

This handy tool is perfect for removing watchband pins. Comes with one 0.80mm pin. The 0.70mm pin works great for removing links from our Ceramic Couture watches.

Item	Order #	Description	Per Pack	12+	6+	1+
E	59-0807	Multi-Function Watch Tool		\$8.93	\$9.45	\$10.50
F	59-0815	.70mm Replacement Pin Set (3 pack)		\$5.14	\$5.45	\$6.05
	59-0808	.80mm Replacement Pin Set (3 pack)		\$5.14	\$5.45	\$6.05



**LINK PIN REMOVER**

This link pin remover is essential for removing pins from watch bracelets. Made of Keltec II glass-filled nylon, this unit includes two extra spacers to accommodate all bracelet sizes and two extra push pins.

Item	Order #	Description	Tip Size	12+	6+	1+
G	59-0810	Link Pin Remover		\$14.41	\$15.26	\$16.95

REPLACEMENT PARTS

Item	Order #	Description	Tip Size	12+	6+	1+
H	59-0811	Standard Pusher Pin	4mm	\$2.51	\$2.66	\$2.95
	59-0812	Medium Pusher Pin	7mm	\$2.51	\$2.66	\$2.95
	59-0814	Large Pusher Pin	12mm	\$2.51	\$2.66	\$2.95

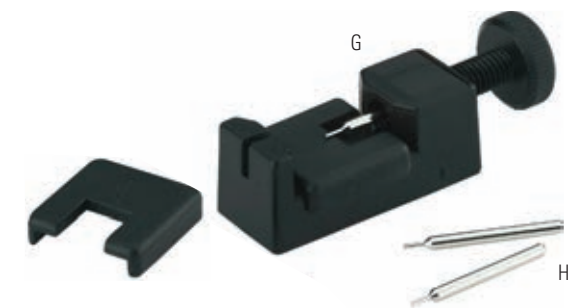

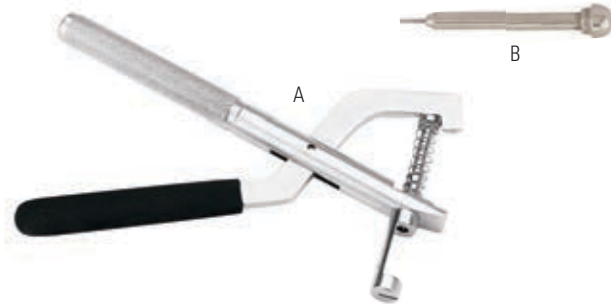

**BRACELET PIN REMOVING PLIERS**

Quickly remove pins from watch bracelets with these easy-to-use pliers. Non-slip handles provide excellent leverage to handle even the most stubborn pins.

Item	Order #	Description	Pin Size	12+	6+	1+
A	64-5003	Economy Pin Pliers		\$19.64	\$20.79	\$23.10
B	64-5004	Replacement Pin	.80 mm	\$2.17	\$2.30	\$2.55
	64-5004	Replacement Pin	1.0 mm	\$2.17	\$2.30	\$2.55



**PIN PUSHER**

Tempered steel blade.

Order #	Description	12+	6+	1+
59-0300	Pin Pusher	\$4.55	\$4.82	\$5.35



**SPECIAL PLIERS FOR REMOVING BRACELET LINKS**

Bracelet link removing pliers

Order #	Description	12+	6+	1+
59-0774	Bracelet Link Removing Pliers	\$19.47	\$20.61	\$22.90



**SPECIAL PLIERS FOR REMOVING BRACELET LINKS**

Bracelet link removing pliers

Order #	Description	12+	6+	1+
59-0773	Bracelet Link Removing Pliers	\$23.72	\$25.11	\$27.90



**WATCHBAND LINK REMOVER**

Easily adjust watchbands using this tool. Perfect for removing clip springs in link watchbands.

Order #	Description	Length	12+	6+	1+
64-5000	Link Remover	5 1/2"	\$9.35	\$9.90	\$11.00



**WATCH BRACELET SCREW REMOVER**

This great new tool is the only way to go when removing double-ended screws. Made of nearly unbreakable, high-impact glass-filled nylon, this tool features one fixed screwdriver blade and one turnable blade. Blades are tempered steel and both are held fast and perfectly aligned to make removing stubborn screws easy.

Order #	Description	12+	6+	1+
64-5010	Screw Remover	\$16.58	\$17.55	\$19.50



**BECO WATCH HAND SETTER**

The Beco Watch Hand Setter uses zero-point-fixing and an attachment for optional movement holders and intermediate plates for adjusting. Flat & Tapered insert. Dimensions: 120mm x 65mm x 55mm (H x W x D)

Includes stake sizes

- 0.5mm
- 0.7mm
- 0.9mm
- 1.2mm
- 1.5mm
- 1.7mm

Order #	Description	12+	6+	1+
59-0770	Hand Setter	\$160.65	\$170.10	\$189.00

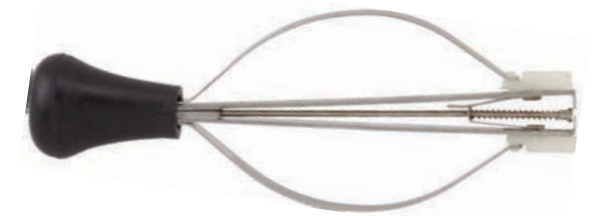

**ECONOMY WATCH HAND REMOVER**

Removes hands on bracelet watches and small instruments.

Order #	Description	12+	6+	1+
58-2799	Watch Hand Remover	\$6.12	\$6.48	\$7.20

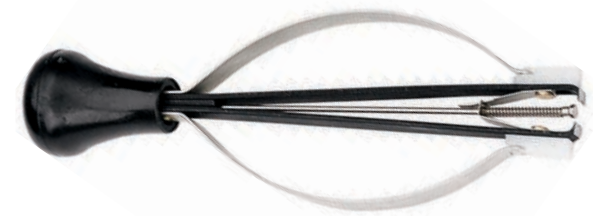

**BERGEON PRESTO REMOVER**

Pusher blocks have fiber tips that will not mar the dial. Jaws retract when side springs are passed. Center plunger holds the hands firmly.

Order #	Description	12+	6+	1+
58-2800	#1 Hand Remover	\$58.61	\$62.06	\$68.95



**LEVERS FOR WATCH HAND**

These watch hand removers made of non-magnetic stainless steel. This watch hand remover works as a lever. You put the ends on either side and under the hands; then just lift off the hands.

Order #	Description	12+	6+	1+
59-0901	Watch Hand Lever	\$12.33	\$13.05	\$14.50





**BECO GLASS REMOVAL TOOL**

This glass-removing tool for plastic glasses is also suitable to open pushed on cases under 40mm.

Order #	Description	12+	6+	1+
59-0765	Glass Removal Tool	\$155.63	\$164.78	\$183.09



**CRYSTAL LIFT AND PLATE**

Removes and inserts 10 to 45mm unbreakable crystals without dismantling the watch. Simple turning action opens and closes the brass jaws. Made in Switzerland.

Order #	Description	12+	6+	1+
64-5104	Bergeon Crystal Lift/Plate	\$73.31	\$77.63	\$86.25
64-5105	Economy Lift/Plate	\$18.49	\$19.58	\$21.75



**RODICO® CLEANING COMPOUND**

Special watchmaker's product removes fingerprints, stains, and excess oil. Soft and pliable, it comes with two sticks per box.

Order #	Description	Size	12+	6+	1+
58-2805	Rodico Cleaning Compound	16 oz	\$14.92	\$15.80	\$17.55



**UV LIGHT BOX**

This UV light box is designed to speed up the curing time for all UV glues.

Order #	Description	12+	6+	1+
12-2054	UV Light Box	\$36.51	\$38.66	\$42.95



**"UV" CLEAR GLASS ADHESIVE**

Creates a crystal clear bond. Expose to UV light to cure in seconds. Use for bonding glass to metal for bonding light colored stained glass (not recommended for deep colored stained glass). 3cc syringe.

Order #	Description	12+	6+	1+
12-2053	Clear Glass Adhesive	\$6.62	\$6.91	\$7.20



**SUC ROCKET CRYSTAL CEMENT**

Highly adhesive, quality cement ensures greater holding power. Can be used on any unbreakable crystal or foilback jobs. Needlepoint tube ensures proper use and does not permit the cement to solidify in the nozzle.

Order #	Description	12+	6+	1+
12-2100	Crystal Cement (20 second curing time)	\$6.21	\$6.48	\$6.75

**"RE-NEW-ALL" PLASTIC RENEWER**

Makes any plastic watch crystal look brand new. Wheel is charged with compound, and plastic crystal is gently buffed.

Order #	Description	Size	12+	6+	1+
47-3100	Crystal Polisher	6-oz bar	\$5.29	\$5.52	\$5.75



**POLYWATCH® SCRATCH REMOVER**

Removes scratches from plastic watch crystals. Simply polish scratch area with a piece of wool for two to three minutes and renew the luster of that worn out crystal.

Order #	Description	Size	12+	6+	1+
64-5100	Scratch Remover	5 grams	\$5.57	\$5.90	\$6.55



**A. WATCH MASKING TAPE 3MM WIDE**

Adhesive Masking tape for masking, protection of watch, jewelry etc.

**B. WATCH MASKING TAPE 6MM WIDE**

Adhesive Masking tape for masking, protection of watch, jewelry etc.

Item	Order #	Description	12+	6+	1+
A	47-3231	Tape 3mm Wide	\$8.79	\$9.17	\$9.55
B	47-3231	Tape 6mm Wide	\$10.21	\$10.66	\$11.10

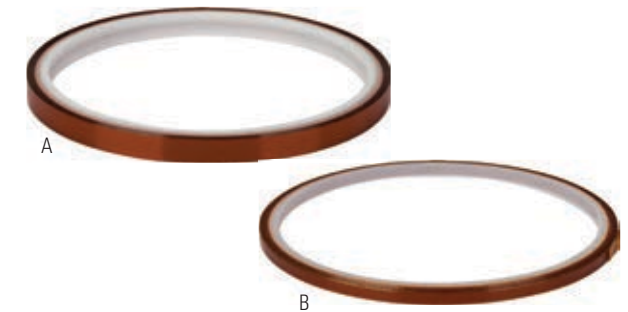

**COMPOUND 7 SILICONE WATCH SEALANT**

Silicone compound withstands high pressures and vacuums. No leaking in water or air even under the most drastic conditions. Unaffected by temperatures - 280°F to 485°F. Will not evaporate, vaporize, harden, break down, and will not effect watch oils.

Order #	Description	12+	6+	1+
58-2557	Silicone Watch Case Sealant	\$6.59	\$6.98	\$7.75



**MICRO-LUBE 2, SYRINGE**

Stem and winding gear lubricant in a 5cc syringe with one tip.

Order #	Description	Size	12+	6+	1+
58-2556	Gear Lubricant in Syringe	5 cc	\$6.67	\$6.96	\$7.25



**MICRO-LUBE 2, JAR**

Stem and winding gear lubricant extra-fine grease exceptional for stem and winding gears. Will not run or spread. Perfect for chronographs.

Order #	Description	Size	12+	6+	1+
58-2558	Gear Lubricant	1 oz jar	\$4.05	\$4.22	\$4.40





**DIP OILER SET**

Non-rolling handles are color-coded for quick identification. Oilers are 3/4" overall; shaft, 2/4". Comes with one each of green, red, blue, and black dips.

Order #	Description	12+	6+	1+
58-2555	Dip Oiler Set (4 piece set)	\$9.44	\$9.99	\$11.10

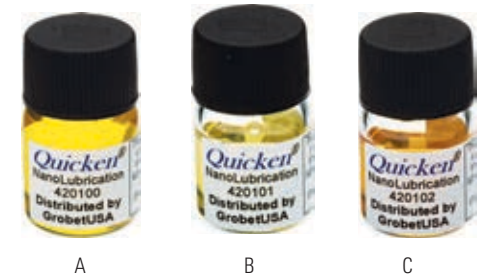

**QUICKEN® LUBE**

NanoLube contains NanoDiamonds, which act as ball bearings and eliminate friction and wear. NanoDiamonds are 0.1-4 nanometer synthetic diamond ball bearings that never wear out. On average, it takes 80,000 NanoLube particles to span the width of a human hair and all particles are spherical, synthetic diamond.

Item	Order #	Description	Size	1+
A	58-2540	NanoLube for Clock	2 ml jar	\$27.60
B	58-2541	NanoLube for Watch	2 ml jar	\$27.60
C	58-2542	NanoLube for Multi Purpose Watch	2 ml jar	\$27.60



**MOEBIUS WATCH AND CLOCK OIL**

These efficient and reliable high-quality lubricants work well for wrist watches, pocket watches, and small and large clocks. Feature very good adherence, non-toxic, and good viscosity. Range of application: -36°C to +80°C.

Item	Order #	Description	Size	1+
D	58-2550	Quartz Watch Oil	20 ml jar	\$42.00
E	58-2551	Wrist Watch Oil	20 ml jar	\$46.50
F	58-2552	Pocket Watch Oil	20 ml jar	\$20.90
G	58-2553	Clock Oil	20 ml jar	\$20.90



**GASKET ASSORTMENT**

A wide selection of popular sizes, meticulously separated by thickness. Comes with four pieces each of 36 different diameters (14.5 to 32.0mm). For use with Seiko®, Citizen®, and most modern quartz watches.



Item	Order #	Thickness	12+	6+	1+
H	59-1050	.04 mm	\$7.45	\$7.78	\$8.10
J	59-1052	.05 mm	\$7.45	\$7.78	\$8.10
K	59-1054	.06 mm	\$7.45	\$7.78	\$8.10
L	59-1056	.07 mm	\$7.45	\$7.78	\$8.10

*Rolex® and Oyster® are registered trademarks of Rolex Watch USA, Inc. The products offered herein are not manufactured, authorized or endorsed by Rolex Watch USA, Inc.*



**66-PIECE THIN O-RING ASSORTMENT**

Comes with three each of 22 popular numbers.

Order #	Description	12+	6+	1+
59-1062	Thin O-Ring Gasket Assortment	\$20.93	\$21.84	\$22.75

**90-PIECE O-RING GASKET ASSORTMENT**

Three each of 30 popular numbers.

Order #	Description	12+	6+	1+
59-1061	O-Ring Gasket Assortment	\$20.70	\$21.60	\$22.50



**90-PIECE FLAT GASKET ASSORTMENT**

Three each of 30 popular numbers.

Order #	Description	12+	6+	1+
59-1060	Flat Gasket Assortment	\$46.37	\$48.38	\$50.40



**105-PIECE CASEBACK GASKET ASSORTMENT FOR USE WITH ROLEX® WATCHES**

Comes with three each of 35 sizes, flat and round.

Order #	Description	12+	6+	1+
59-1065	Caseback Gasket Assortment	\$60.40	\$63.02	\$65.65

*Rolex® and Oyster® are registered trademarks of Rolex Watch USA, Inc. The products offered herein are not manufactured, authorized or endorsed by Rolex Watch USA, Inc.*



**54-PIECE FLAT-CASEBACK GASKET ASSORTMENT**

Three each of 18 popular numbers.

Order #	Description	12+	6+	1+
59-1064	Flat Gasket Assortment	\$23.18	\$24.19	\$25.20



**SILICONE SEALANT BOX**

Keep watch gaskets lubricated and flexible with the silicone sealant box. Sponges are impregnated with silicone grease. Simply insert your gaskets, close the lid, and twist for a gasket with a tighter, longer seal.

Order #	Description	12+	6+	1+
64-5112	Silicone Sealant Box	\$5.01	\$5.23	\$5.45



Watch Tools and Supplies

Watch Tools and Supplies





**SCREWDRIVER SET WITH STAND**

Kit Order # 59-0906

Blade Size	Color	12+	6+	1+
Set of .8, 1, 1.2, 1.4, 1.6, 1.8, 2mm	Multi	\$101.15	\$107.10	\$119.00

**SCREWDRIVER REPLACEMENT BLADES**

Screw driver replacement blades for 59-0906, .08 mm pack of 3.

Order # 59-0906

Blade Size	Color	12+	6+	1+
.08mm	Orange	\$2.51	\$2.66	\$2.95
1mm	Gray	\$2.51	\$2.66	\$2.95
1.2mm	Yellow	\$2.51	\$2.66	\$2.95
1.4mm	Black	\$2.51	\$2.66	\$2.95
1.6mm	Red	\$2.51	\$2.66	\$2.95
1.6mm	Purple	\$3.36	\$3.56	\$3.95
1.8mm	Purple	\$2.51	\$2.66	\$2.95
2mm	Green	\$2.51	\$2.66	\$2.95



**OPTICAL SCREWS**

Assorted yellow and white screws for eyeglasses.



Order #	Description	12+	6+	1+
58-2500	Optical Screw Assortment	\$13.56	\$14.36	\$15.95



**SCREW-HOLDING TWEEZERS**

Ideal for battery clamps and screws, the v-shaped notch makes it possible to hold the smallest screws for assembly.

Order #	Description	Length	12+	6+	1+
57-7525	Screw-Holding Tweezers	4 3/8"	\$9.35	\$9.90	\$11.00



**BERGEON ROLLER REMOVER**

V-slot slips between hub of staff and seat of roller. Slight pressure on sides of tool is sufficient to lift roller from balance seat. Extra fine jaws permit use on both small and standard sizes.

Order #	Description	12+	6+	1+
47-1026	Roller Remover	\$30.56	\$32.36	\$35.95

**BERGEON PLASTIC BLOWER**

Large capacity, tough plastic air reservoir. Ridges on body preventing rolling. Plastic washer in body is treated to prevent drying out.

Order #	Description	Length	12+	6+	1+
59-0484	Plastic Blower	4 1/2"	\$26.05	\$27.59	\$30.65



**DUST BLOWER**

Rubber blower that is compact, high quality, and handy to use.

Order #	Description	WxL	12+	6+	1+
23-0900	Dust Blower	1 3/4"x3 1/2"	\$4.63	\$4.91	\$5.45



**CLOCK AND INSTRUMENT CLEANING BRUSHES**

Bristles are available in varying degrees of hardness for cleaning and dusting clocks, instruments, and parts. Bristles measure 4 1/2" (114mm) long and 5/8" (16mm) deep. Overall length 10 1/4" (260mm).

**Half-Hard Cleaning Brushes:** For general cleaning

**Half-Soft Cleaning Brushes:** For more delicate parts

**Soft Cleaning Brushes:** For removing dust

Item	Order #	Description	12+	6+	1+
A	58-2700	Half-Hard Cleaning Brushes	\$6.38	\$6.75	\$7.50
B	58-2701	Half-Soft Cleaning Brushes	\$6.59	\$6.98	\$7.75
C	58-2702	Soft Cleaning Brushes	\$7.18	\$7.61	\$8.45



**FIBERBOARD BENCH PLATE**

This enameled fiberboard will not warp and features grooved edges to prevent parts from rolling off.

Order #	Description	WxLxH	12+	6+	1+
13-3805	Fiberboard Bench Plate	9"x16"x1/4"	\$8.93	\$9.45	\$10.50



**ANTI-STATIC BENCH MAT**

Flexible mat is used for organizing tools and projects.

Order #	Description	WxL	12+	6+	1+
59-0488	Light Green Mat	14"x9 1/2"	\$11.50	\$12.00	\$12.50



**THE ORIGINAL FLORIDA PITHWOOD**

Box of selected button pith is ideal for holding small parts for inspection and cleaning oil from parts. Assorted pieces.



Order #	Description	12+	6+	1+
58-2704	Florida Pithwood	\$5.70	\$6.03	\$6.70



**IMPORTED PEGWOOD**

Selected orangewood for cleaning pivot holes and various other uses. Approximately 18-24 sticks per bundle.

Order #	Diameter	Length	12+	6+	1+
58-2703	2mm	5 3/4"	\$7.52	\$7.97	\$8.85





5 3/4" W x 10 1/4" L x 1 1/4" Thickness

A

**ORGANIZATION TRAYS AND VIALS**

These paper-covered trays feature magnetic closure and a clear view lid. Vials have swing-top lids. Small bottle: 6mm hole  
Large bottle: 10mm hole

Item	Order #	Description	12+	6+	1+
A	59-2115	Black Tray (24 lime green vials)	\$22.72	\$23.71	\$24.70
B	59-2105	Black Tray (36 black vials)	\$18.49	\$19.30	\$20.10
C	59-2110	Large Plastic Vial with Lime Green Lid	\$0.92	\$0.96	\$1.00
D	59-2100	Small Plastic Vial with Black Lid	\$0.60	\$0.62	\$0.65



6" W x 9 1/2" L x 1" Thickness

B



1/2" H

C



1/2" W x 1 1/2" H

D



**WATCH REPAIR TRAY WITH COVER**

Six-compartment tray features a clear cover. They are stackable.

Order #	Description	WxL H	12+	6+	1+
15-2073	Repair Tray with Cover	9 1/2"x4 3/8"x3/4"	\$15.26	\$16.16	\$17.95



**TRANSPARENT DUST COVER**

This transparent dust cover will keep your watch parts free of dust. The blue color tray with six storage compartments (three small, two large and a round center) for easy separation and division. With a durable plastic cover, it works better than the old-time glass ones. Compact size 4" x 3".

Order #	Description	12+	6+	1+
59-0905	Dust Cover	\$6.63	\$7.02	\$7.80



**MOVEMENT TRAYS**

Stackable round trays feature five compartments.

Order #	Description	WxH	12+	6+	1+
15-2074	Movement Trays (set of 6)	3 1/4"x3/4"	\$11.18	\$11.66	\$12.15



**CLEAR GLASS MOVEMENT DISH WITH KNOB**

This movement dish does an excellent job of keeping dust from entering. Edges of cover and cup are ground to form a tight seal.

Order #	Description	WxH	12+	6+	1+
58-2705	Movement Cover and Tray	3 1/2"x2 1/4"	\$18.19	\$19.26	\$21.40

**GLASS ALCOHOL CUP**

This plain alcohol cup is used for benzene or other solutions. Edges of covers and cups are ground to form a tight seal, keeping dust from entering and protecting solutions from evaporation.

Order #	Description	Size	12+	6+	1+
64-5116	Alcohol Cup	8 oz jar	\$21.25	\$22.50	\$25.00



4" diameter x 2 3/4" H

**ROUND TIN CANS**

Made of tin, these are perfect for storing watch parts, stones, or findings.



Order #	Description	WxH	12+	6+	1+
15-2075	Tin Cans (pack of 12)	2"x3/4"	\$12.33	\$13.37	\$14.85



**NO-LINT, ANTI-TARNISH TISSUES**

Best quality. Made in the USA.



Order #	Description	WxL	12+	6+	1+
23-5550	Anti-Tarnish Tissue (box of 1,000)	4"x4"	\$5.60	\$5.93	\$6.59



**DELUXE SPRING BAR TOOL**

With replaceable stainless steel screw end tips, these are used for the removal of spring bars from watches.

Item	Order #	Description	12+	6+	1+
A	47-8900	Deluxe Spring Bar Tool	\$4.76	\$5.04	\$5.60
B	47-8910	Pointed Tip	\$1.91	\$2.03	\$2.25
C	47-8911	Forked Tip	\$1.91	\$2.03	\$2.25



**SPRING BAR TOOL**

Use to change spring bars. They feature a millimeter scale on the handle with screw-in tips.

Item	Order #	Description	12+	6+	1+
D	47-8920	Spring Bar Tool	\$5.06	\$5.36	\$5.95
E	47-8921	Round Tip	\$0.89	\$0.95	\$1.05
F	47-8922	Forked Tip	\$0.89	\$0.95	\$1.05
G	47-8930	Spring Bar Remover	\$4.59	\$4.86	\$5.40

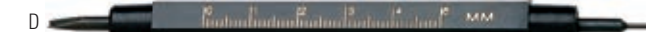





**BERGEON SPRING BAR GAUGE**

Specially designed tool is used to gauge the space between case ends in order to select proper size spring bar.

Item	Order #	Description	12+	6+	1+
	64-4085	Spring Bar Gauge	\$9.31	\$9.86	\$10.95



**EZ CHANGE SPRING BAR KITS AND REFILLS**

This 84-piece Spring Bar Kit includes 12 pieces of each per vial: 10mm, 12mm, 14mm, 16mm, 18mm, 20mm, and 22mm. Refills may be ordered by size.

Order #	Description	Length	12+	6+	1+
59-2050	84-Piece Kit	3/8-7/8	\$32.33	\$35.06	\$38.95



**STAINLESS STEEL DOUBLE SHOULDER SPRING BARS**

Kit consists of 288 pieces total. Color of holding case may vary.

Order #	Description	12+	6+	1+
59-2020	Spring Bar Assortment Kit (288-Pieces)	\$15.82	\$16.51	\$17.20



**SEMI-STAINLESS STEEL DOUBLE SHOULDER SPRING BARS**

Kit consists of 400 semi-stainless pieces of the most commonly used spring bars. 200 pieces are extra thin and 200 pieces are regular. Made of semi-stainless steel.

Order #	Description	12+	6+	1+
59-2030	Spring Bar Assortment Kit (400-Pieces)	\$13.80	\$14.40	\$15.00



**DOUBLE SHOULDER SPRING BAR KIT**

Includes 700 regular pieces total.

- 100-5/16" (.90mm)
- 100-3/8" (1.10mm)
- 100-7/16" (1.20mm)
- 100-1/2" (1.50mm)
- 100-5/8" (1.80mm)
- 100-11/16" (1.90mm)
- 100-3/4" (2.10mm)



Order #	Description	1+
59-1500	Spring Bar Kit (700-Pieces)	\$15.75



**EXTRA-THIN SEMI-STAINLESS SPRING BAR KIT**

Includes 200 semi-stainless pieces total.

- 20- #1 (1/4")
- 20- #2 (5/16")
- 20- #3 (3/8")
- 20- #4 (7/16")
- 20- #5 (1/2")
- 20- #6 (9/16")
- 20- #7 (5/8")
- 20- #8 (11/16")
- 20- #9 (3/4")
- 20- #10 (13/16")



Item	Order #	Description	12+	6+	1+
A	59-2010	Spring Bar Kit (200-Pieces)	\$11.99	\$12.69	\$14.10
B	59-2000	Spring Bar Kit (200-Pieces)	\$14.58	\$15.44	\$17.15



**STAINLESS STEEL STRAIGHT BRACELET PIN ASSORTMENT**

60-piece assortment offering six each of 10 diameters (0.8mm through 1.8mm in 0.1mm increments). 30mm length.



Order #	Description	12+	6+	1+
58-2502	Bracelet Pin Assortment	\$8.59	\$9.09	\$10.10



**STAINLESS STEEL STAMPED END BRACELET PINS ASSORTMENT**

One end is stamped for a tight friction fit. 27mm length with five different diameters (0.8mm, 0.9mm, 1.0mm, 1.1mm, and 1.2mm). Each pin size comes with a heavy and light stamp.

Order #	Description	12+	6+	1+
58-2501	60-Piece Pin Assortment	\$8.59	\$9.09	\$10.10



**COTTER PIN ASSORTMENT**

Five pieces each in 36 different lengths: 4.5mm to 22.00mm in 0.5mm increments. All in 0.9mm diameter, being the most commonly used.

Description	Length (mm)	12+	6+	1+
Cotter Pin Assortment		\$25.33	\$26.82	\$29.80
Refills (by size, 10 pieces per vial)	4.5-22.0	\$2.55	\$2.70	\$3.00



**HOW TO ORDER**

In the continental U.S., orders placed before 5:00 p.m. (4:00 p.m. Pacific time) will be shipped the same day. Canadian accounts must place orders by 3:00 p.m. Canada local time for same day shipping. International accounts must place orders by 2:00 p.m. Central time for same-day shipping. Place orders toll-free by phone, fax, email [sales@Stuller.com](mailto:sales@Stuller.com), or on [Stuller.com](http://Stuller.com).

**STULLER.COM**

Take advantage of quick and easy ordering and enjoy the following benefits:

- Check current pricing and availability on more than 200,000 products — 24/7, 365 days a year.
- Place orders quickly and accurately.
- Track shipments, view previous orders, and print any of your invoices.
- Use Schedule Order to add to your cart all day and submit your order automatically at your predetermined time.
- Live, text-based chat is available to assist you Monday through Friday, 9:00 a.m. to 6:00 p.m. Central time.
- For WEB ASSISTANCE call 877-619-2174.

Click SIGN UP at the top of [Stuller.com](http://Stuller.com) to create your online account. We'll verify your information and send an email confirmation that your login/password is ready for use. Go to [Stuller.com](http://Stuller.com), click Login, and enter it for full access to the site. Use the Quick Order feature on the home page when you know exactly what you want to order.

**PHONE**

U.S. and CANADA PHONE: 800-877-7777	INTERNATIONAL PHONE: 337-262-7700
--	--------------------------------------

To ensure accuracy when placing orders for an item, be prepared to give the following information: account number, account name, your name, complete series number, karat, color, size, quantity, conditional sale number (if applicable).

**FAX**

24/7-HOUR FAX: 800-444-4741	24/7-HOUR FAX: 337-981-1655
-----------------------------	-----------------------------

**SHIPPING INFORMATION**

Most items in this catalog are available for same-day shipping, next-day delivery. Ground delivery and motor freight service is available for items that are too large or too heavy for next-day delivery to be cost effective. Your sales consultant will discuss alternative shipping options with you when you order. Freight and insurance are billed at the time of shipment.

- **TRUCK SHIPMENTS/UPS/FEDEX**

All carriers are responsible and liable for any damages that occur during transit. If you suspect any damage or shortage caused during transit, do not sign freight bill or receipt without making a notation on the freight bill. Retain all packing material and shipping cartons until the carrier has made an inspection. File a claim directly with the carrier within 15 days. Stuller CANNOT file a claim for you. Additional charges for inside delivery, lift gate and, COD.

- **HAZARDOUS MATERIALS SHIPPING**

The Department of Transportation (DOT) governs the labeling, packaging, and handling of certain materials. These standards increase costs from shipping companies for handling (currently an additional \$20–\$30 to each separate package or chemical). Some of your packaging amounts may change. We continually update our shipping policies and try to minimize the DOT charges where possible. Material Safety Data Sheets are sent with all required items and contain important safety recommendations and emergency procedures. Additional copies are available by contacting Tools Customer Service. Keep on file for quick reference. No returns on hazardous. Must be hazmat certified to return.

**CANCELLATIONS AND RETURNS**

When ordering online, we encourage you to use the Schedule Order feature, which will allow you to make changes to your order prior to it being submitted at your cutoff time.

Once an order has been submitted online, by telephone, or fax, you will need to contact a sales associate to determine whether your order can be changed or cancelled.

**WHERE AND HOW TO RETURN**

We want you to be happy with everything you purchase from us. If you are not satisfied and need to return merchandise, we will give you full credit, provided you follow these procedures (Excludes special ordered, non-returnable items.).

- Simply go to [Stuller.com/StartMyReturn](http://Stuller.com/StartMyReturn) to create a return request. Once you've completed the request, the system will generate a unique barcode and merchandise return form for your convenience.

or

- Send the completed Merchandise Return Form or a copy of the original invoice with the returned items. Easily download a copy of our merchandise return form at [Stuller.com>Returns](http://Stuller.com>Returns). Please include the reason for return.

Return merchandise in its original condition and packaging, including envelopes, bags, and boxes. Merchandise should be securely packaged and insured. Stuller is not responsible for returns that are damaged in transit.

Insure for full value and return to  
**Stuller, Inc., Attn: Customer Returns**  
**302 Rue Louis XIV, Lafayette, LA 70508**

All returns must be shipped prepaid (no CODs).

Upon receiving your return, we will exchange, replace, or credit. You will receive credit in the same manner as you paid for the merchandise.

Stuller is not responsible for returns that are damaged in transit. Items with manufacturing defects may be returned for exchange. Items that were altered, cut, or manufactured to your specifications cannot be accepted for credit or exchange. Be aware that normal shipping charges do apply to the exchange order.

Refused, undeliverable, or merchandise returned that was not purchased from Stuller will be charged for the shipping costs of returning it to you.

Thank you for adhering to these policies. If you have any questions concerning the return of merchandise or credit for the return of merchandise, please contact our Customer Service Department at **800-877-7777**, press 3, or [info@Stuller.com](mailto:info@Stuller.com). Or view [Stuller.com>Returns](http://Stuller.com>Returns) for further assistance and forms.



### CÓMO HACER PEDIDOS

En los Estados Unidos contiguos, los pedidos hechos antes de las 5:00 p.m. (4:00 p.m. Zona Pacífico) serán enviados el mismo día. Los clientes de Canadá deberán hacer sus pedidos a las 3:00 p.m. a más tardar, para que estos puedan ser enviados el mismo día. Los demás clientes internacionales deberán hacer sus pedidos a las 2:00 p.m. Zona Centro a más tardar, para que estos puedan ser enviados el mismo día. Puede hacer pedidos a través de llamadas telefónicas gratuitas, fax, correo electrónico a la dirección sales@Stuller.com, o en nuestra página de internet Stuller.com.

### STULLER.COM

Haga sus pedidos a través de nuestra página de internet, y disfrute de los siguientes beneficios:

- Verifique precios y disponibilidad de más de 200,000 productos – 24/7, 365 días de año.
- Procese sus pedidos con facilidad y precisión.
- Rastree sus pedidos, accese pedidos previos, e imprima cualquiera de sus facturas.
- Use Schedule Order para agregar a su bolsa de compras durante el día y su orden será procesada automáticamente a la hora que usted predetermine.
- Chat en vivo disponible para atenderlo de lunes a viernes de las 9:00 a.m. a las 6:00 p.m. Zona Centro.
- Para asistencia de Web llame al 877-619-2174.

Presione SIGN UP en la parte de arriba de Stuller.com para crear su cuenta en nuestra página de internet. Nosotros verificaremos su información y le enviaremos un correo electrónico confirmando que su ID de inicio y contraseña están listos para ser usados. Una vez que reciba este correo, vaya a Stuller.com, presione Login, y ponga los datos para poder tener acceso completo a nuestra página de internet. Use Quick Order en la página principal cuando sepa exactamente lo que desea ordenar.

### TELÉFONO

E.U.A. y CANADA	INTERNACIONAL
TELÉFONO: 800-877-7777	TELÉFONO: 337-262-7700

Cuando llame para hacer un pedido, y para asegurarnos que este sea correcto, favor de tener la siguiente información a la mano: número de cuenta, nombre de la cuenta, su nombre, número del artículo, tipo de kilate, color, dimensión, cantidad y número de venta condicional (si aplica).

### FAX

FAX 24/7: 800-444-4741	FAX 24/7: 337-981-1655
------------------------	------------------------

### DEVOLUCIONES Y CANCELACIONES

Cuando ordene por nuestra página de internet, le recomendamos que use Schedule Order, con lo cual podrá hacer cambios a su pedido antes de que este sea procesado a su hora límite.

Una vez que su orden sea procesada en nuestra página de internet, por teléfono o por fax, usted tendrá que contactar a uno de nuestros agentes de ventas para determinar si puede hacer cambios o cancelar su pedido.

### DÓNDE Y CÓMO HACER DEVOLUCIONES

Nosotros esperamos que usted quede satisfecho con todo lo que compra de nuestra compañía. Si no está satisfecho y necesita devolver mercancía, le daremos crédito completo por el costo del artículo siempre y cuando siga los siguientes procedimientos (excluye pedidos especiales y productos no retornables):

- Simplemente vaya a [Stuller.com/StartMyReturn](http://Stuller.com/StartMyReturn) para generar una solicitud de devolución. Una vez que haya completado la solicitud, el sistema generará un código de barra único y un formato para regresar mercancía para mayor conveniencia.

o

- Envíe el Formato de Devolución de Mercancía o una copia de la factura original junto con el producto que desea devolver. Fácilmente descargue una copia del formato para devolver mercancía en [Stuller.com>Returns](http://Stuller.com>Returns). Favor de incluir la razón de la devolución.

Regrese la mercancía en su condición original y con el empaque original, incluyendo sobres, bolsas y cajas. Los artículos deberán ser cuidadosamente empaquetados y asegurados. Stuller no se hará responsable por devoluciones que sean dañadas en el proceso de envío.

Asegure el producto por su valor total, y devuelva a **Stuller, Inc., Attn: Customer Returns**  
**302 Rue Louis XIV, Lafayette, LA 70508**

Todas las devoluciones deberán ser prepagadas (No CODs).

En cuanto recibamos su devolución cambiaremos, reemplazaremos o acreditaremos su cuenta. Recibirá crédito de la misma manera en que pago por la mercancía.

Stuller no es responsable por devoluciones que sean dañadas durante el envío. Productos con defectos de fábrica pueden ser cambiados. Productos que sean alterados, cortados o manufacturados a sus especificaciones no podrán ser aceptados para cambio o devolución de crédito. Tenga en cuenta que cargos de envío aplicarán al cambiar una orden.

En caso de que la mercancía sea devuelta porque se ha negado a recibirla, no se ha podido entregar, o la mercancía devuelta no haya sido comprada en Stuller, se le cobrarán los costos de devolución de envío a usted.

Gracias por seguir estos procedimientos. Si tiene alguna pregunta en cuanto a la devolución de mercancía o el crédito de alguna devolución, favor de contactar a nuestro departamento de Servicio al Cliente al número **800-877-7777**, presione el 3 o [info@Stuller.com](mailto:info@Stuller.com). Para mayor asistencia o formatos visite [Stuller.com>Returns](http://Stuller.com>Returns).

**WEIGHTS AND MEASURES**

TO CONVERT	MULTIPLY BY	TO OBTAIN
Centimeters	0.3937	Inches
Cubic Centimeters	0.06102	Cubic Inches
Cubic Inches	16.39	Cubic Centimeters
Cubic Feet	28.32	Cubic Centimeters
Feet	30.48	Centimeters
Feet	0.3048	Meters
Grams	0.64301	Pennyweights (DWT)
Grams	0.03527	Ounces, Avoir
Grams	0.03215	Ounces, Troy
Inches	2.54	Centimeters
Inches	25.4	Millimeters
Kilograms	35.274	Ounces, Avoir
Kilograms	32.1507	Ounces, Troy
Kilograms	643.014	Pennyweights ((DWT)
Kilograms	2.205	Pounds, Avoir
Liters	1.057	Quarts (Liquid)
Meters	3.281	Feet
Meters	39.37	Inches
Meters	1.094	Yards
Millimeters	0.03937	Inches
Ounces, Avoir	28.35	Grams
Ounces, Avoir	.9115	Ounces, Troy
Ounces, Avoir	18.2291	Pennyweights ((DWT)
Ounces, Troy	20	Pennyweights ((DWT)
Ounces, Troy	0.0311	Kilograms
Ounces, Troy	1.0971	Ounces, Avoir
Ounces, Troy	31.1035	Grams
Pennyweights ((DWT)	1.5552	Grams
Pennyweights ((DWT)	0.001555	Kilograms
Pennyweights ((DWT)	0.05486	Ounces, Avoir
Pennyweights (DWT)	0.05	Ounces, Troy
Pounds, Avoir	0.4536	Kilograms
Pounds, Avoir	16	Ounces, Avoir
Pounds, Avoir	14.5833	Ounces, Troy
Pounds, Troy	12	Ounces, Troy
Square Centimeters	0.155	Square Inches
Square Feet	144	Square Inches
Square Inches	6.452	Square Centimeters
Square Inches	645.2	Square Millimeters
Square Millimeters	0.00155	Square Inches
Yard	0.9144	Meters

GRAM WEIGHT	
1 gram	= 15.43 grains Troy
1 grain	= 0.0648 grams
1.555 grams	= 1 pennyweight (DWT)
1 grain	= 64.80 milligrams
31.104 grams	= 1 ounce Troy
1 milligram	= .015432 grams
28.35 grams	= 1 ounce Avoir
1 gram	= .035274 Avoir oz
1 gram	= .032151 Troy oz

TROY WEIGHT	
Used in weighing precious metals	
24 grains	= 1 pennyweight (DWT)
1 kilogram	= 2.68 pounds
20 DWT	= 1 ounce Troy
1 kilogram	= 32.15 Troy ozs
12 ounces	= 1 pound Troy
1 kilogram	= 2.2046 lbs. Avoir
5,760 grains	= 1 pound Troy
1 kilogram	= 35.2740 oz. Avoir
480 grains	= 1 Troy oz
1 kilogram	= 15,432 grains
Troy oz	= 1.0972 Avoir oz

AVOIRDUPOIS WEIGHT	
Used in weighing base metals	
16 drams (or drachms)	= 1 oz Avoir
1 pound Avoir	= 14.5833 Troy oz
16 ounces	= 1 pound Avoir
1 ounce Avoir	= 0.914 Troy oz
16 ounces	= 7,000 grains
1 pound Avoir	= 7,000 grains
28 pounds	= 1 quarter English
1 ounce Avoir	= 437.5 grains
4 quarters	= 1 hundredweight (cwt.)
1 pound Avoir	= .4359 kilo
20 hundredweight	= 1 ton Avoir

**CIRCLES AND SQUARES CIRCUMFERENCES/AREAS**

**Rules relating to circles and squares**

The circumference of a circle is the diameter times 3.1416. The area of a circle is the radius squared times 3.1416. The area of a square is the length of one side squared.

SIZE IN INCHES	CIRCUMFERENCE OF CIRCLE (IN)	AREA OF CIRCLE	AREA OF SQUARE
1	3.142	.7854	1.000
2	6.283	3.142	4.000
3	9.425	7.069	9.000
4	12.57	12.57	16.00
5	15.71	19.64	25.00
6	18.85	28.27	36.00
7	21.99	38.48	49.00
8	25.13	50.27	64.00
9	28.28	63.62	81.00
10	31.42	78.54	100.00
11	34.56	95.03	121.00

**TEMPERATURE CONVERSION**

Conversion Formulas °F = (9/5 x °C) + 32° °C = 5/9 (°F - 32°)

°F	°C	°F	°C	°F	°C	°F	°C	°F	°C	°F	°C
600	316	830	443	1120	604	1410	766	1640	893	1930	1054
610	321	840	449	1130	610	1420	771	1650	899	1940	1060
620	327	850	454	1140	616	1430	777	1660	904	1950	1066
630	332	860	460	1150	621	1440	782	1670	910	1960	1071
640	338	870	466	1160	627	1450	788	1680	916	1970	1077
650	343	880	471	1170	632	1460	793	1690	921	1980	1082
660	349	890	477	1180	638	1470	799	1700	927	1990	1088
670	354	900	482	1190	643	1480	804	1710	932	2000	1093
680	360	910	488	1200	649	1490	810	1720	938	2010	1099
690	366	920	493	1210	654	1500	816	1730	943	2020	1104
700	371	930	499	1220	660	1510	821	1800	982	2030	1110
710	377	1000	538	1230	666	1520	827	1810	988	2040	1116
720	382	1010	543	1240	671	1530	832	1820	993	2050	1121
730	388	1020	549	1250	677	1540	838	1830	999	2060	1127
740	393	1030	554	1260	682	1550	843	1840	1004	2070	1132
750	399	1040	560	1270	688	1560	849	1850	1010	2080	1138
760	404	1050	566	1280	693	1570	854	1860	1016	2090	1143
770	410	1060	571	1290	699	1580	860	1870	1021	2100	1149
780	416	1070	577	1300	704	1590	866	1880	1027	2110	1154
790	421	1080	582	1310	710	1600	871	1890	1032	2120	1160
800	427	1090	588	1320	716	1610	877	1900	1038	2130	1166
810	432	1100	593	1330	721	1620	882	1910	1043		
820	438	1110	599	1400	760	1630	888	1920	10		



GAUGES TO INCHES TO MILLIMETERS

B & S GAUGE	INCH DECIMAL	MILLIMETER	INCH FRACTION
2	.0258	6.543	—
—	0.250	6.350	1/4
—	0.234	5.953	15/64
3	0.229	5.827	—
—	0.219	5.556	7/32
4	0.204	5.189	—
—	0.203	5.154	11/64
—	0.188	4.762	3/16
5	0.182	4.621	—
—	0.172	4.366	11/64
6	0.162	4.115	—
—	0.156	3.969	5/32
7	0.144	3.664	—
—	0.141	3.572	9/64
8	0.128	3.263	—
—	0.125	3.175	1/8
9	0.114	2.906	—
—	0.109	2.778	7/64
10	0.102	2.588	—
—	0.094	2.381	3/32
11	0.091	2.304	—
12	0.081	2.052	—
—	0.078	1.984	5/64
13	0.072	1.828	—
14	0.064	1.628	—
—	0.063	1.588	1/16
15	0.057	1.449	—

B & S GAUGE	INCH DECIMAL	MILLIMETER	INCH FRACTION
16	0.051	1.291	—
—	0.047	1.191	3/64
17	0.045	1.149	—
18	0.040	1.024	—
19	0.036	0.912	—
20	0.032	0.812	—
—	0.031	0.795	1/32
21	0.028	0.723	—
22	0.025	0.644	—
23	0.023	0.573	—
24	0.020	0.511	—
25	0.018	0.455	—
26	0.016	0.405	—
—	0.016	0.396	1/64
27	0.014	0.360	—
28	0.013	0.321	—
29	0.011	0.286	—
30	0.010	0.255	—
31	0.009	0.226	—
32	0.008	0.200	—
33	0.007	0.180	—
34	0.006	0.160	—
35	0.006	0.142	—
36	0.005	0.130	—
37	0.005	0.114	—
38	0.004	0.100	—

SERIES #	PAGE										
ALLOY/GRAIN	359	HERCULOY	360	SIZING STOCK -	24143	69	3353	398	3663	398	
ANIMAL		HORSESHOE		SQUARE	372	24283	71	3363	397	3667	399
STAMPINGS	394	STAMPINGS	393	SIZING STOCK -	24313	71	3364	397	3669	397	
ART BRASS	360	LASER WIRE KIT	366	TRIANGLE	372	24314	71	3365	390	3674	398
BEZEL STOCK	373	LASER WIRE		SOLDER WIRE	382	24913	70	3372	390	3683	397
BOX3	78	SPOOL	366	SPEED WIRE	367	24914	70	3382	390	3709	389
BOYS HEAD		LOW DOME		SQUARE		24915	70	3383	390	3710	389
STAMPINGS	389	WIRE	371	STAMPINGS	385	262	68	3384	390	3713	389
BRASS GRAIN	360	NATURE		SQUARE WIRE	372	263	68	3385	390	3746	399
BRONZE CUBES	360	STAMPINGS	394	SR5.6	72	2770	549	3387	390	3756	390
CASTING		OCTAGON		SR6	72	28293	71	3391	399	3757	395
GRAIN	354, 356	STAMPINGS	387	SR7	72	28294	71	3392	399	3758	395
CHIP SOLDER	381	OVAL		STAR		28506	71	3393	388	3761	393
CHRISTMAS		STAMPINGS	384	STAMPINGS	391	3134	399	3394	399	3773	397
STAMPINGS	393	PASTE SOLDER	383	TEARDROP		3138	400	3390	388	3800	388
CROSS		PLATINUM		STAMPINGS	387	3139	400	3396	388	3801	388
STAMPINGS	391	SOLDER	380	TRIANGLE		3140	400	3397	388	3812	395
DIAMOND		RBAT	54	STAMPINGS	388	3141	400	3398	388	3813	398
CUT WIRE	376	RBAT101	54	TUBING	374	3142	400	3399	390	3814	396
DIAMOND		RD1	72	WHITE BRONZE		3165	398	3400	397	3817	395
STAMPINGS	386	RD2	72	GRAIN	360	3166	398	3401	399	3824	398
DOG TAGS	400	RD3	72	YGF HALF		3168	397	3419	390	3830	398
EBAT	52, 53, 53, 55	RECTANGLE		ROUND WIRE	371	3169	399	3420	390	3831	398
EBAT1.5V	57	STAMPINGS	386	101	71	3170	399	3482	390	3832	398
EBAT12V	57	RING BLANKS	375	102	71	3178	397	3536	397	3837	399
EBAT9V	56, 57	ROUND		109	71	3183	399	3539	390	3842	395
EBATAA	56, 57	STAMPINGS	384	20312	69	3184	398	3540	397	3850	396
EBATAAA	56, 57	ROUND WIRE	364	20313	69	3192	396	3541	397	3861	395
EBATAAAA	56	SHAMROCK		20999	71	3210	397	3542	397	3862	398
EBATC	56, 57	STAMPINGS	394	21459	549	3213	396	3543	397	3877	396
EBATCHARGER	58	SHEET	361	21460	549	3215	399	3544	390	3878	396
EBATD	56, 57	SILVER		21461	549	3218	398	3548	399	3879	396
EBATHA	57	COMPARISON	401	22467	72	3224	397	3597	396	3880	399
EBATSP	53	SILVER GRAIN	358	22485	71	3251	390	3598	396	3881	396
FABRICATED		SILVER PATTERN		22532	71	3252	390	3600	399	3882	396
METALS	348	WIRE	377	23040	2	3253	390	3601	398	3883	396
FINE SILVER		SILVER SLIT COIL	376	2305	549	3257	398	3602	399	3884	396
BEZEL	376	SILVER SOLDER		2306	549	3258	397	3606	396	3885	396
GIRLS HEAD		STRIP	382	23373	71	3261	398	3607	399	3886	396
STAMPINGS	389	SILVER TWISTED		23384	549	3267	390	3608	395	3888	396
GOLD SOLDER	378	WIRE	376	23406	549	3279	397	3620	396	3889	396
GOLD SOLDER -		SIZING STOCK	370	23822	72	3282	397	3621	395	3891	388
COLOR MATCH	380	SIZING STOCK -		23853	72	3283	397	3631	395	3892	388
GOLD STRIP	363	COMFORT FIT	371	23860	72	3286	397	3632	398	3893	396
GRAIN		SIZING STOCK -		24035	69	3287	390	3637	398	3894	396
REPLINISHER	360	FLAT	369	24055	70	3291	390	3638	398	3898	395
HALF MOON		SIZING STOCK -		24056	70	3295	399	3643	396	3903	400
STAMPINGS	391	HALF ROUND	370	24057	69	3296	388	3652	395	863	70
HEART		SIZING STOCK -		24058	69	3297	388	3656	389	864	70
STAMPINGS	388, 392	PREFORM	368	24059	69	3345	399	3660	398	865	70

All items are priced at jeweler's cost, are sold each, unless otherwise noted, and are subject to change without notice. Visit [Stuller.com](http://Stuller.com) for our complete product selections, current pricing, and quantity price breaks. | 635

SERIES #	PAGE										
866	70	10-7032	24	10-8091	6	10-8182	38	10-9143	21	11-0909	134
867	70	10-7033	24	10-8092	6	10-8190	39	10-9144	21	11-0910	134
94	71	10-7034	24	10-8093	6	10-8191	39	10-9145	21	11-2203	8
10-1077	24	10-7035	24	10-8094	6	10-8192	39	10-9146	21	11-2204	8
10-1078	24	10-7036	23	10-8100	7	10-8208	38, 477	10-9162	477	11-2205	8
10-1079	24	10-7037	23	10-8101	7	10-8320	16	10-9163	477	11-2660	9
10-4080	25	10-7038	23	10-8102	7	10-8321	40	11-0651	49	11-3009	37
10-4203	265	10-7039	23	10-8103	7	10-8322	40	11-0652	49	11-3010	37
10-4204	265	10-7040	23	10-8104	7	10-8324	232	11-0700	13	11-3060	9
10-4210	265	10-7041	23	10-8105	7	10-8325	232	11-0701	13	11-3100	9
10-4500	265	10-7042	23	10-8106	7	10-8326	233	11-0702	13	11-3101	9
10-4510	265	10-7043	23	10-8107	7	10-8327	11	11-0703	13	11-3102	9
10-4551	13	10-7044	23	10-8108	7	10-8330	232	11-0704	13	11-3103	9
10-4552	13	10-7050	24, 37	10-8109	7	10-8340	14	11-0705	13	11-3110	9
10-4553	13	10-7060	38	10-8110	7	10-8342	14	11-0706	13	11-3177	497
10-4554	13	10-7061	38	10-8111	7	10-8343	14	11-0707	13	11-3200	9
10-4555	265	10-7062	38	10-8112	7	10-8344	14	11-0708	13	11-3201	9
10-5510	265	10-7063	38	10-8113	7	10-8407	6	11-0709	13	11-3202	9
10-5520	265	10-7064	38	10-8114	7	10-8408	6	11-0710	13	11-3203	9
10-6000	6	10-7065	38	10-8115	7	10-8409	6	11-0711	13	11-3204	9
10-6015	265	10-7070	39, 498	10-8116	7	10-8410	6	11-0720	15	11-3205	9
10-6090	8	10-7071	39, 498	10-8117	7	10-8420	6	11-0721	15	11-3206	9
10-6091	8	10-7072	39, 498	10-8120	39	10-9098	21	11-0722	15	11-3330	9
10-6092	8	10-7073	39, 498	10-8121	39	10-9099	21	11-0723	15	11-3390	10
10-6093	8	10-7074	39, 498	10-8122	8	10-9100	21	11-0724	15	11-3391	10
10-6094	8	10-7075	39, 498	10-8123	8	10-9101	21	11-0725	15	11-3392	10
10-6095	8	10-7076	39, 498	10-8124	8	10-9102	21	11-0726	15	11-3400	10
10-6100	6	10-7080	492	10-8125	8	10-9103	21	11-0730	15	11-3401	10
10-6102	6	10-7090	492	10-8126	8	10-9104	18, 20, 21	11-0731	15	11-3402	10
10-6103	6	10-7100	24	10-8127	38	10-9105	21	11-0732	15	11-3403	10
10-6104	6	10-7101	24	10-8128	38	10-9106	21	11-0736	15	11-3404	10
10-7000	22	10-7102	24	10-8131	8	10-9107	21	11-0737	15	11-3405	10
10-7001	22	10-7103	24	10-8132	8	10-9108	21	11-0739	15	11-3406	10
10-7002	22	10-7104	24	10-8140	17	10-9109	21	11-0740	15	11-3408	10
10-7005	22	10-7105	24	10-8141	17	10-9110	21	11-0741	15	11-3418	13
10-7006	22	10-7106	24	10-8142	17	10-9111	21	11-0745	15	11-3420	13
10-7007	22	10-7107	24	10-8143	17	10-9112	21	11-0746	15	11-3421	13
10-7010	22	10-7108	23	10-8151	8	10-9113	21	11-0747	15	11-3422	13
10-7011	22	10-7120	24	10-8152	8	10-9114	21	11-0750	16	11-3423	13
10-7012	22	10-7121	24	10-8153	8	10-9115	18	11-0751	16	11-3424	13
10-7015	22	10-7122	24	10-8155	8	10-9117	18	11-0752	16	11-3425	13
10-7016	22	10-7125	24	10-8164	17	10-9130	21	11-0758	14	11-3426	13
10-7017	22	10-7140	23	10-8165	17	10-9131	21	11-0800	16	11-3427	13
10-7020	22	10-8075	7	10-8166	17	10-9132	21	11-0900	134	11-3428	13
10-7021	22	10-8076	7	10-8167	17	10-9133	21	11-0901	134	11-3429	13
10-7022	22	10-8077	7	10-8168	17	10-9134	20	11-0902	134	11-3430	11
10-7025	22	10-8078	7	10-8173	17	10-9135	21	11-0903	134	11-3431	11
10-7026	22	10-8079	7	10-8174	17	10-9136	21	11-0904	134	11-3500	10
10-7027	22	10-8081	7	10-8175	17	10-9140	21	11-0906	134	11-3501	10
10-7030	24	10-8082	7	10-8176	17	10-9141	21	11-0907	134	11-3502	10
10-7031	24	10-8090	6	10-8181	38	10-9142	21	11-0908	134	11-3503	10

SERIES #	PAGE										
11-3504	10	11-6001	26	11-6074	36	11-6146	30	11-6223	35	11-6317	34
11-3505	10	11-6002	26	11-6080	29	11-6147	30	11-6244	36	11-6320	34
11-3506	12	11-6003	26	11-6081	29	11-6148	30	11-6245	36	11-6322	34
11-3507	12	11-6004	26	11-6082	29	11-6149	30	11-6246	36	11-6324	28
11-3520	11	11-6005	26	11-6083	29	11-6150	30	11-6247	36	11-6325	28
11-3521	11	11-6006	26	11-6084	29	11-6151	30	11-6248	36	11-6326	28
11-3522	11	11-6007	26	11-6085	29	11-6155	30	11-6249	36	11-6327	28
11-3523	11	11-6008	26	11-6086	29	11-6156	30	11-6255	39	11-6328	28
11-3524	11	11-6009	26	11-6087	29	11-6157	30	11-6256	39	11-6329	28
11-3525	11	11-6010	263	11-6088	29	11-6158	30	11-6257	39	11-6330	28
11-3526	11	11-6012	26	11-6091	32	11-6159	30	11-6260	25	11-6331	28
11-3527	11	11-6013	26	11-6092	32	11-6160	30	11-6261	25	11-6333	28
11-3528	11	11-6014	26	11-6093	32	11-6165	31	11-6262	35	11-6334	28
11-3529	11	11-6015	26	11-6094	32	11-6166	31	11-6263	35	11-6335	28
11-4260	25	11-6016	26	11-6095	32	11-6167	31	11-6264	35	11-6336	28
11-4261	25	11-6017	26	11-6096	32	11-6168	31	11-6266	35	11-6350	32
11-4270	25	11-6018	26	11-6100	27	11-6169	31	11-6267	35	11-6351	32
11-4271	25	11-6019	26	11-6101	27	11-6171	31	11-6268	35	11-6353	32
11-4280	25	11-6020	26	11-6102	27	11-6172	32	11-6269	35	11-6354	32
11-4281	25	11-6021	26	11-6103	27	11-6175	31	11-6270	35	11-6356	32
11-4290	25	11-6022	263	11-6105	27	11-6176	31	11-6271	35	11-6357	32
11-4291	25	11-6023	263	11-6106	27	11-6177	31	11-6272	35	11-6360	33
11-4300	25	11-6025	26	11-6107	27	11-6178	31	11-6274	35	11-6361	33
11-4301	25	11-6026	26	11-6108	27	11-6179	31	11-6275	35	11-6362	33
11-4310	25	11-6027	26	11-6110	27	11-6181	31	11-6276	35	11-6363	33
11-4311	25	11-6028	26	11-6111	27	11-6185	31	11-6277	35	11-6364	33
11-4320	25	11-6029	26	11-6112	27	11-6186	31	11-6280	36	11-6366	33
11-4321	25	11-6030	26	11-6113	27	11-6187	31	11-6281	36	11-6367	33
11-4330	25	11-6031	26	11-6115	27	11-6188	31	11-6282	36	11-6368	33
11-4331	25	11-6032	26	11-6116	27	11-6189	31	11-6283	36	11-6369	33
11-4340	25	11-6033	26	11-6117	27	11-6190	31	11-6290	36	11-6370	33
11-4341	25	11-6034	26	11-6118	27	11-6191	31	11-6291	36	11-6371	33
11-4350	25	11-6040	26	11-6120	27	11-6192	31	11-6292	36	11-6372	33
11-4351	25	11-6041	26	11-6121	30	11-6193	32	11-6293	36	11-6373	33
11-4360	25	11-6042	26	11-6124	30	11-6195	32	11-6294	36	11-6374	33
11-4361	25	11-6043	26	11-6125	30	11-6196	32	11-6295	36	11-6375	33
11-4370	25	11-6044	26	11-6126	30	11-6197	32	11-6296	36	11-6376	33
11-4371	25	11-6045	26	11-6127	30	11-6198	32	11-6297	36	11-6411	20
11-4380	25	11-6046	26	11-6128	30	11-6199	32	11-6300	34	11-6412	20
11-4381	25	11-6047	26	11-6129	30	11-6201	35	11-6301	34	11-6413	20
11-4390	25	11-6048	26	11-6130	30	11-6202	35	11-6302	34	11-6414	20
11-4391	25	11-6049	26	11-6131	30	11-6203	35	11-6303	34	11-6415	20
11-4400	25	11-6052	26	11-6135	30	11-6204	35	11-6304	34	11-6512	19
11-4401	25	11-6060	29	11-6136	30	11-6210	35	11-6305	34	11-6514	19
11-5100	23	11-6061	29	11-6137	30	11-6211	35	11-6307	34	11-6515	19
11-5102	23	11-6062	29	11-6138	30	11-6212	35	11-6310	34	11-6516	19
11-5103	23	11-6063	29	11-6139	30	11-6213	35	11-6312	34	11-6517	19
11-5104	23	11-6064	29	11-6140	30	11-6220	35	11-6313	34	11-6518	19
11-5105	23	11-6065	36	11-6141	30	11-6221	35	11-6315	34	11-6519	19
11-6000	26	11-6072	36	11-6145	30	11-6222	35	11-6316	34	11-6520	31



SERIES #	PAGE										
11-6521	31	11-8148	28	12-2111	43	13-1000	331	13-3765	88	14-0154	239
11-6522	31	11-8150	28	12-2112	43	13-1699	314	13-3766	88	14-0155	239
11-6523	31	11-8152	29	12-2113	44	13-1701	315, 333	13-3771	88	14-0157	542
11-6524	31	11-8154	29	12-2114	43	13-1708	314	13-3800	88	14-0160	542
11-6525	31	11-8156	29	12-2115	44	13-1709	315, 333	13-3805	623	14-0161	543
11-6526	19	11-8158	29	12-2117	42	13-1722	330	13-4300	332	14-0200	238
11-6527	19	11-8162	29	12-2118	42	13-1723	315, 333	13-8122	332	14-0410	562
11-6528	19	11-8164	37	12-2120	42	13-1724	315, 333	13-8123	332	14-0420	562
11-6530	33	11-8166	37	12-2121	45	13-1781	330	14-0008	549	14-0522	557
11-6531	33	11-8168	37	12-2122	43	13-1790	328	14-0009	549	14-0523	557
11-6532	33	11-8170	37	12-2125	42	13-1791	328	14-0012	555	14-0524	557
11-6533	33	11-8172	29	12-2131	45	13-1792	331	14-0013	555	14-0525	557
11-6534	33	11-8174	29	12-2132	45	13-1798	330	14-0014	555	14-0526	557
11-6535	33	11-8180	34	12-2135	45	13-1799	329	14-0015	555	14-0527	557
11-6540	33	11-8182	34	12-2136	44	13-1800	329	14-0016	555	14-0600	556
11-6541	33	11-8184	34	12-2137	43	13-1801	329	14-0017	555	14-0601	556
11-6542	33	11-8186	34	12-2138	44	13-1802	329	14-0018	561	14-0602	556
11-6543	33	11-8190	22	12-2270	99, 252	13-1803	329	14-0021	550	14-0603	556
11-6544	33	11-8192	22	12-2300	252	13-1805	329	14-0022	550	14-0604	556
11-6545	33	11-8194	22	12-3000	46	13-1806	329	14-0024	550	14-0605	556
11-6600	37	11-8196	22	12-3010	100	13-1808	329	14-0025	550	14-0606	556
11-6601	37	11-8197	22	12-3020	101	13-1810	331	14-0090	554	14-0607	556
11-6602	37	11-8198	22	12-3050	100	13-1818	330	14-0092	554	14-0701	557
11-6603	37	11-8200	133	12-3107	100	13-1819	330	14-0110	540	14-0751	557
11-6620	34	11-8204	22	12-3109	100	13-1820	331	14-0115	541	14-0753	558
11-7100	40	11-8205	22	12-3110	100	13-1821	329	14-0116	541	14-0755	552
11-7101	40	11-8206	21	12-3115	100	13-1823	331	14-0117	541	14-0756	551
11-7102	141	11-8207	21	12-3117	100	13-1824	331	14-0120	541	14-0757	551
11-8040	16	11-8210	133	13-0430	86	13-1825	331	14-0121	541	14-0758	551
11-8041	16	11-8211	133	13-0436	87	13-1826	331	14-0122	541	14-0759	551
11-8042	16	11-8212	133	13-0438	87	13-1831	331	14-0123	541	14-0760	551
11-8043	16	11-8220	133	13-0449	86	13-1833	331	14-0124	541	14-0761	558
11-8044	16	11-8230	133	13-0455	84	13-1834	331	14-0125	541	14-0765	552
11-8045	16	11-8235	133	13-0456	85	13-1840	310	14-0127	541	14-0769	190, 559
11-8099	35	11-8240	22	13-0457	85	13-1841	331	14-0128	541	14-0770	190, 552
11-8100	27	11-8242	22	13-0458	85	13-1901	335	14-0129	541	14-0771	552
11-8110	27	11-8244	22	13-0459	85	13-1902	335	14-0130	541	14-0772	552
11-8114	28	11-8246	22	13-0460	88	13-1903	335	14-0132	541	14-0777	559
11-8116	28	11-8278	18	13-0461	85	13-2016	332	14-0135	541	14-0778	559
11-8118	28	11-8279	18	13-0462	85	13-2030	335	14-0136	541	14-0779	559
11-8120	28	11-8280	18	13-0463	85	13-2031	335	14-0139	575	14-0780	558
11-8122	28	11-8281	18	13-0464	85	13-2032	335	14-0141	543	14-0781	558
11-8124	28	12-0451	43	13-0465	85	13-2033	335	14-0143	542	14-0782	552, 558
11-8126	28	12-2030	252	13-0466	85	13-3000	93	14-0145	543	14-0783	558
11-8134	28	12-2050	42	13-0467	85	13-3001	93	14-0146	238	14-0789	544
11-8136	28	12-2051	44	13-0468	85	13-3002	93	14-0147	239	14-0811	543
11-8138	28	12-2053	618	13-0469	85	13-3030	93	14-0148	239	14-0812	542
11-8140	28	12-2054	618	13-0470	85	13-3200	92	14-0149	239	14-1002	544
11-8142	28	12-2056	45	13-0510	89	13-3205	93	14-0150	239	14-1015	555
11-8144	28	12-2080	252	13-0516	89	13-3207	93	14-0151	239	14-1016	555
11-8146	28	12-2100	618	13-0517	89	13-3760	88	14-0153	239	14-1017	555

SERIES #	PAGE										
14-1024	555	14-1659	552	14-5063	190, 554	15-2066	76	16-3990	109	16-6006	105
14-1025	555	14-1660	190, 553	14-5064	190, 554	15-2067	76	16-3991	109	16-6007	105
14-1026	555	14-1661	190, 553	14-5065	190, 554	15-2068	76	16-3992	109	16-6009	105
14-1220	553	14-1662	190, 553	15-0012	206	15-2069	76	16-4001	109	16-6010	105
14-1300	556	14-1663	190, 553	15-0501	207	15-2070	77	16-4002	108	16-6011	104
14-1301	556	14-1664	190, 553	15-0502	207	15-2071	77	16-4005	109	16-6012	104
14-1302	556	14-1665	190, 553	15-0503	207	15-2073	624	16-4006	109	16-6013	104
14-1303	556	14-1667	558	15-0504	207	15-2074	624	16-4007	109	16-6014	104
14-1306	556	14-1780	562	15-0505	207	15-2075	625	16-4008	109	16-6016	104
14-1307	556	14-1781	559	15-0506	207	15-2081	209	16-4262	107	16-6017	104
14-1308	556	14-1790	190, 559	15-0509	206	15-2082	209	16-4314	107	16-6018	104
14-1309	556	14-1795	190, 559	15-0510	206	15-2083	210	16-4402	106	16-6019	104
14-1402	556	14-1840	559	15-0511	206	15-2084	210	16-4464	106	16-6021	104
14-1403	556	14-1845	559	15-0512	206	15-5050	278	16-4562	106	16-6022	104
14-1404	556	14-1850	559	15-0513	206	15-5055	278	16-4624	106	16-6023	104
14-1500	544	14-1855	559	15-0514	206	15-5060	278	16-5965	106	16-6024	104
14-1501	544	14-2010	563	15-0515	206	16-0510	113	16-5966	106	16-6025	104
14-1502	544	14-2011	563	15-0516	206, 207	16-0520	113	16-5967	106	16-6026	104
14-1503	544	14-2030	563	15-0517	206, 207	16-0540	113	16-5968	106	16-6027	104
14-1504	544	14-2031	563	15-0518	206	16-0550	113	16-5969	106	16-6028	104
14-1505	544	14-2032	563	15-0519	206	16-0551	112	16-5970	106	16-6029	104
14-1506	544	14-2040	563	15-0520	206, 207	16-0552	112	16-5971	106	16-6052	104
14-1507	544	14-2050	552, 563	15-0521	207	16-0560	112	16-5972	106	16-6053	104
14-1508	544	14-2055	563	15-0522	207	16-0565	112	16-5973	106	16-6054	104
14-1509	544	14-2350	552	15-0524	206	16-0570	112	16-5974	106	16-6055	104
14-1510	544	14-2865	173	15-0525	206, 207	16-0575	112	16-5975	106	16-6057	104
14-1511	544	14-3120	567	15-0526	154	16-0580	112	16-5976	106	16-6058	104
14-1520	145	14-3125	567	15-0530	206	16-0585	112	16-5979	106	16-6059	104
14-1523	546	14-4492	244	15-0531	206	16-0590	112	16-5981	106	16-6070	104
14-1600	553	14-4493	244	15-0580	216	16-0595	112	16-5982	106	16-6071	104
14-1601	553	14-4494	244	15-1000	205	16-0598	113	16-5984	106	16-6072	104
14-1602	553	14-4495	244	15-1105	204	16-0599	113	16-5985	105	16-7000	105
14-1603	553	14-4496	244	15-1109	204	16-2250	111	16-5986	105	16-7001	105
14-1607	560	14-4497	244	15-1110	204	16-2256	111	16-5987	105	16-7002	105
14-1609	560	14-4498	244	15-1112	204	16-2257	111	16-5988	105	16-7003	105
14-1610	560	14-4990	244	15-1116	204	16-2597	111	16-5989	105	16-7007	105
14-1620	562	14-4997	244	15-2009	205	16-2701	111	16-5990	105	16-7008	105
14-1621	561	14-4999	244	15-2050	208	16-3100	113	16-5991	105	16-7009	105
14-1622	561	14-5000	244	15-2051	209	16-3111	113	16-5992	105	16-7010	105
14-1623	561	14-5002	244	15-2052	209	16-3112	113	16-5993	105	16-7050	107
14-1624	560	14-5004	244, 291	15-2053	209	16-3980	109	16-5994	105	16-7051	107
14-1625	560	14-5005	244, 291	15-2054	209	16-3981	109	16-5995	105	16-7052	107
14-1626	560	14-5010	550	15-2055	209	16-3982	109	16-5996	105	16-7053	108
14-1627	561	14-5015	550	15-2056	209	16-3983	109	16-5997	105	16-7054	108
14-1628	543	14-5020	550	15-2057	209	16-3984	109	16-5998	105	16-7055	109

SERIES #	PAGE										
17-0746	432, 518	17-1260	488	17-4514	494	17-6243	490	17-7719	491	18-0545	96
17-0747	432, 518	17-1270	488	17-4515	494	17-6245	490	17-7722	491	18-1530	117
17-0748	501	17-1383	491	17-4516	494	17-6255	490	17-7726	491	18-1725	114
17-0749	501	17-1384	491	17-4517	494	17-6256	490	17-8700	498	18-1730	114
17-0750	501	17-1385	491	17-4518	494	17-6257	490	17-8710	498	18-1735	114
17-0751	501	17-2005	490	17-4839	494	17-6265	490	17-8720	498	18-1740	114
17-0752	501	17-2006	490	17-4890	495	17-6266	490	17-8732	498	18-1750	114
17-0756	554	17-2007	490	17-4900	494	17-6430	491	17-8734	498	18-1760	114
17-0757	556	17-3150	496	17-4902	494	17-6431	491	17-8743	498	18-1770	114
17-0760	500	17-3153	497	17-4904	494	17-6432	491	17-9001	499	18-1780	114
17-0762	500	17-3154	496	17-4906	494	17-6433	491	17-9002	499	18-1790	114
17-0763	500	17-3155	496	17-4908	494	17-7100	492	17-9003	499	18-1810	114
17-0764	500	17-3315	497	17-4910	494	17-7101	492	17-9004	499	18-1811	114
17-0765	500	17-3317	497	17-4912	494	17-7102	492	17-9460	479	18-1812	114
17-0770	500	17-3320	496	17-4914	494	17-7103	492	17-9470	479	18-1813	114
17-0775	500	17-3325	496	17-4916	494	17-7104	492	17-9480	479	18-1814	114
17-0776	500	17-3400	496	17-4918	494	17-7105	492	17-9490	479	18-1815	114
17-0780	224	17-3401	496	17-4920	494	17-7106	493	17-9550	498	18-1816	114
17-0786	224	17-3410	496	17-5000	479	17-7107	493	17-9552	498	18-1817	114
17-0788	224	17-3413	496	17-5011	479	17-7160	491	17-9560	479	18-1818	114
17-0790	224	17-3414	496	17-5013	479	17-7162	491	17-9562	479	18-1819	114
17-0792	224	17-3519	495	17-5025	479	17-7163	491	17-9570	479	18-1821	114
17-0798	224	17-3520	495	17-5026	479	17-7164	491	17-9580	479	18-1822	114
17-0800	500	17-3559	495	17-5533	489	17-7165	491	17-9590	479	18-1823	114
17-0801	500	17-3560	495	17-5544	489	17-7166	491	18-0500	95	18-1824	114
17-0802	500	17-3599	495	17-5545	489	17-7170	491	18-0502	95	18-1825	114
17-0803	500	17-3600	495	17-5546	489	17-7175	491	18-0504	138	18-1826	114
17-0820	500	17-3639	495	17-5560	489	17-7200	489	18-0505	138	18-1827	114
17-0823	501	17-3640	495	17-5565	489	17-7203	489	18-0506	138	18-1829	114
17-0846	432, 518	17-3659	495	17-5566	489	17-7224	489	18-0507	138	18-1831	114
17-0847	432	17-3660	495	17-5603	489	17-7227	489	18-0509	137	18-1833	114
17-0881	225	17-3679	495	17-5604	489	17-7245	490	18-0510	95	18-1835	114
17-0882	225	17-3680	495	17-5605	489	17-7250	489	18-0516	95	18-1837	114
17-0883	225	17-3681	495	17-5606	489	17-7251	489	18-0517	95	18-1840	114
17-0884	225	17-3711	495	17-5607	488	17-7252	489	18-0518	95	18-1845	114
17-0905	499	17-3720	495	17-5608	488	17-7253	489	18-0519	95	18-1850	114
17-1000	501	17-3769	495	17-5609	488	17-7254	489	18-0520	95	18-1855	114
17-1020	501	17-3770	495	17-5610	488	17-7255	488	18-0521	95	18-1860	114
17-1105	495	17-4499	494	17-5611	488	17-7257	488	18-0525	95	18-1865	114
17-1106	495	17-4500	494	17-5612	488	17-7258	489	18-0526	95	18-1870	114
17-1107	495	17-4501	494	17-5713	490	17-7301	493	18-0530	96	18-1875	114
17-1108	495	17-4502	494	17-5714	490	17-7302	493	18-0531	96	18-1880	114
17-1109	495	17-4503	494	17-5715	490	17-7303	493	18-0532	96	18-1885	114
17-1110	492	17-4505	494	17-6150	495	17-7304	493	18-0535	96	18-1886	114
17-1111	492	17-4506	494	17-6151	495	17-7510	490	18-0537	96	18-1890	135
17-1120	493	17-4507	494	17-6152	495	17-7513	490	18-0538	96	18-1891	135
17-1201	494	17-4508	494	17-6153	495	17-7515	490	18-0539	96	18-1892	135
17-1202	495	17-4510	494	17-6154	495	17-7516	490	18-0540	96	18-1893	135
17-1203	495	17-4511	494	17-6156	495	17-7517	490	18-0541	96	18-1894	119
17-1204	495	17-4512	494	17-6157	495	17-7519	490	18-0542	96	18-1895	119
17-1207	495	17-4513	494	17-6235	490	17-7610	490	18-0543	96	18-1896	119

SERIES #	PAGE										
18-1897	119	18-2607	118	18-4060	115	18-5026	115	19-5030	132	20-2922	136
18-1898	119	18-2608	118	18-4061	115	18-5027	115	19-5031	132	20-2924	136
18-1899	119	18-2609	118	18-4062	115	18-5028	115	19-6000	132	20-2930	136
18-1960	119	18-2611	118	18-4063	115	18-5029	115	19-6001	132	20-2932	136
18-1961	119	18-3010	117	18-4064	115	18-5031	115	19-6002	132	20-2934	136
18-1962	119	18-3012	117	18-4065	115	18-5033	115	19-6003	132	21-0003	8
18-1963	119	18-3014	117	18-4066	115	18-5035	115	19-6004	132	21-0016	184
18-1964	119	18-3015	117	18-4067	115	18-5037	115	19-6005	132	21-0025	170
18-1965	119	18-3016	117	18-4068	115	18-5040	115	19-6010	133	21-0025	305
18-2070	119	18-3018	117	18-4069	115	18-5042	115	19-6011	133	21-0053	171
18-2071	119	18-3021	117	18-4070	115	18-5045	115	19-6012	133	21-0080	171
18-2072	119	18-3023	117	18-4075	115	18-5047	115	19-6013	133	21-0081	171
18-2073	119	18-3380	118	18-4110	115	18-5050	115	19-9247	137	21-0082	171
18-2074	119	18-3390	118	18-4111	115	18-5052	115	19-9250	139	21-0083	171
18-2075	119	18-3400	118	18-4112	115	18-5057	115	19-9252	139	21-0084	171
18-2076	119	18-3410	118	18-4113	115	18-5089	133	19-9260	137	21-0160	173
18-2077	119	18-3420	118	18-4114	115	18-5180	97	19-9270	139	21-0162	173
18-2078	119	18-3430	118	18-4115	115	18-5188	120	19-9272	139	21-0180	172
18-2079	119	18-3460	118	18-4116	115	18-5189	120	19-9273	130, 139	21-0181	172
18-2080	119	18-3480	118	18-4117	115	18-5337	117	19-9276	137	21-0183	172
18-2160	119	18-3500	118	18-4118	115	18-5338	117	19-9277	137	21-0184	172
18-2161	119	18-3520	118	18-4119	115	18-5339	117	19-9280	135	21-0186	172
18-2162	119	18-3540	118	18-4120	115	18-5340	117	20-1040	120	21-0187	172
18-2163	119	18-3560	118	18-4121	115	18-5342	117	20-1041	120	21-0188	172
18-2164	119	18-3580	118	18-4122	115	18-5343	117	20-1042	120	21-0189	172
18-2165	119	18-3610	118	18-4123	115	18-5344	117	20-1043	120	21-0207	156
18-2166	119	18-3611	118	18-4124	115	18-5345	117	20-1044	120	21-0208	156
18-2167	119	18-4009	117	18-4125	115	18-5346	117	20-1045	120	21-0209	156
18-2168	119	18-4010	117	18-4126	115	18-5347	117	20-1046	120	21-0215	159
18-2169	119	18-4012	117	18-4127	115	19-3152	121	20-1047	120	21-0216	159
18-2170	119	18-4014	117	18-4128	115	19-3160	121	20-1048	120	21-0217	159
18-2171	119	18-4015	117	18-5000	116	19-3220	114	20-1049	120	21-0218	159
18-2172	119	18-4016	117	18-5005	116	19-3860	121	20-1050	120	21-0219	159
18-2173	119	18-4018	117	18-5009	115	19-5000	132	20-1051	120	21-0220	159
18-2174	119	18-4021	117	18-5010	115	19-5001	132	20-1052	120	21-0221	159
18-2592	118	18-4023	117	18-5011	115	19-5002	132	20-1053	120	21-0222	159
18-2593	118	18-4025	117	18-5012	115	19-5006	132	20-1200	135	21-0223	159
18-2594	118	18-4027	117	18-5013	115	19-5008	132	20-1205	135	21-0224	159
18-2595	118	18-4029	117	18-5014	115	19-5009	132	20-1206	135	21-0225	159
18-2596	118	18-4031	117	18-5015	115	19-5010	132	20-1207	135	21-0226	159
18-2597	118	18-4050	115	18-5016	115	19-5014	132	20-1208	135	21-0227	159
18-2598	118	18-4051	115	18-5017	115	19-5015	132	20-1209	135	21-0228	159
18-2599	118	18-4052	115	18-5018	115	19-5017	132	20-1210	135	21-0229	159
18-2600	118	18-4053	115	18-5019	115	19-5020	132	20-1211	135	21-0230	159
18-2601	118	18-4054	115	18-5020	115	19-5021	132	20-2820	136	21-0231	159
18-2602											



SERIES #	PAGE										
21-0239	159	21-0435	160	21-0534	157	21-0712	166	21-1346	157	21-5001	148
21-0245	159	21-0436	156	21-0535	157	21-0713	166	21-1347	157	21-5002	148
21-0246	159	21-0440	165	21-0536	157	21-0714	166	21-1350	157	21-5003	148
21-0247	159	21-0441	165	21-0537	157	21-0715	166	21-1351	157	21-5004	148
21-0248	159	21-0442	165	21-0538	157	21-0716	166	21-1352	157	21-5005	148
21-0249	159	21-0443	165	21-0539	157	21-0717	166	21-1355	157	21-5006	148
21-0250	168	21-0444	165	21-0540	161	21-0718	166	21-1356	157	21-6550	168
21-0255	168	21-0445	165	21-0541	161, 601	21-0719	166	21-1357	157	21-6925	187
21-0256	168	21-0446	165	21-0542	161	21-0720	166	21-1358	157	21-6930	187
21-0257	159	21-0449	165	21-0544	159	21-0721	166	21-1359	157	21-6935	187
21-0258	159	21-0452	8	21-0545	159	21-0722	166	21-1360	157	21-6940	187
21-0260	165	21-0455	162	21-0546	159	21-0723	166	21-1361	157	21-6945	187
21-0261	165	21-0456	162	21-0547	159	21-0724	166	21-1362	157	21-6950	187
21-0262	165	21-0460	185	21-0555	264	21-0725	166	21-1363	157	21-6960	187
21-0263	165	21-0465	292	21-0620	163	21-0726	166	21-1364	157	21-6965	187
21-0264	165	21-0470	167	21-0621	163	21-0727	166	21-1365	157	21-6966	187
21-0265	165	21-0474	167	21-0622	163	21-0955	158	21-1366	157	21-6970	187
21-0266	160	21-0476	167	21-0623	163	21-0956	158	21-1367	157	21-7000	187
21-0267	160	21-0478	167	21-0624	163	21-0957	158	21-1368	157	21-7001	187
21-0268	160	21-0480	167	21-0625	163	21-0958	158	21-1369	157	21-7002	187
21-0269	161	21-0482	167	21-0626	163	21-0960	139	21-1370	157	21-7003	187
21-0279	161	21-0484	167	21-0627	163	21-1000	169	21-1371	157	21-7005	148
21-0308	156	21-0486	167	21-0628	163	21-1100	169	21-1372	157	21-7007	187
21-0309	156	21-0488	167	21-0630	163	21-1125	168	21-1383	186	21-7008	188
21-0320	156	21-0489	167	21-0631	163	21-1127	168	21-1411	162	21-7009	188
21-0321	156	21-0490	167	21-0632	163	21-1128	170, 306	21-1412	162	21-7010	188
21-0322	156	21-0491	292	21-0633	163	21-1140	169	21-1414	162	21-7011	187
21-0323	156	21-0492	292	21-0634	164	21-1150	169	21-1416	162	21-7012	187
21-0325	166	21-0493	292	21-0640	164	21-1200	25, 293	21-1418	162	21-7013	187
21-0382	165	21-0494	292	21-0641	164	21-1201	25, 293	21-1419	162	21-7014	187
21-0383	165	21-0495	162	21-0642	164	21-1202	25, 293	21-1422	162	21-7015	187
21-0390	158	21-0496	162, 601	21-0643	164	21-1203	25, 293	21-1423	162	21-7026	187
21-0392	166	21-0498	8	21-0650	163	21-1204	25, 293	21-1424	162	21-7040	149
21-0393	166	21-0499	292	21-0651	164	21-1205	25, 293	21-1425	162	21-7042	149
21-0394	166	21-0501	292	21-0652	164	21-1206	25, 293	21-1427	162	21-7043	149
21-0395	186	21-0508	162	21-0653	163	21-1207	25, 293	21-1778	200	21-7044	149
21-0396	186	21-0519	160	21-0660	164	21-1208	25, 293	21-2510	169	21-7045	149
21-0400	184	21-0520	160	21-0661	164	21-1209	25, 293	21-2520	169	21-7046	149
21-0401	184	21-0521	160	21-0662	164	21-1210	25, 293	21-2600	170	21-7047	197
21-0402	184	21-0522	160	21-0663	164	21-1211	25, 293	21-2601	170	21-7048	197
21-0403	184	21-0523	160	21-0670	164	21-1305	186	21-2602	170	21-7049	149, 197
21-0410	184	21-0524	160	21-0672	164	21-1306	186	21-2603	76	21-7050	192
21-0420	185	21-0525	160	21-0673	164	21-1307	186	21-2800	159	21-7051	192
21-0421	185	21-0526	160	21-0674	164	21-1308	186	21-2812	159	21-7052	192
21-0422	185	21-0527	160	21-0680	164	21-1331	186	21-2817	159	21-7053	149
21-0429	185	21-0528	160	21-0681	164	21-1332	186	21-2822	159	21-7054	149
21-0430	160	21-0529	160	21-0682	164	21-1339	186	21-2835	158	21-7055	149
21-0431	160	21-0530	160	21-0683	164	21-1340	157	21-2880	158	21-7056	149
21-0432	160	21-0531	157	21-0684	164	21-1341	157	21-2895	158	21-7057	197
21-0433	160	21-0532	157	21-0710	166	21-1342	157	21-4999	148	21-7058	197
21-0434	160	21-0533	157	21-0711	166	21-1345	157	21-5000	148	21-7059	149, 197

SERIES #	PAGE										
21-7060	149, 197	21-9148	163	22-1152	148	22-4773	196	22-5929	181	22-7946	192
21-7400	200	21-9149	163	22-1153	148	22-4776	196	22-5930	181	22-8000	192
21-7401	200	21-9150	163	22-1170	150	22-4778	196	22-5940	181	22-8150	191
21-7602	200	21-9151	163	22-1180	149	22-4779	197	22-5941	181	22-8152	191
21-7603	200	21-9152	163	22-1185	148	22-5506	178	22-5951	180	22-8700	194
21-7604	200	21-9153	163	22-1200	150	22-5507	178	22-6006	178	22-8701	194
21-7700	200	21-9154	163	22-1201	150	22-5509	178	22-6007	178	22-8702	194
21-7701	200	21-9161	164	22-1300	147	22-5600	178	22-6008	178	22-8711	194
21-7710	200	21-9162	164	22-1301	147	22-5700	179	22-6009	178	22-8712	194
21-7720	200	21-9163	164	22-1302	147	22-5701	179	22-7403	182, 183	22-8770	194
21-7827	188	21-9165	164	22-1304	146	22-5702	179	22-7424	182	22-9001	154
21-7828	188	21-9166	164	22-1305	148	22-5703	179	22-7425	182	22-9002	154
21-7829	188	21-9167	164	22-1600	153	22-5800	179	22-7426	182	23-0001	221
21-7830	188	22-0085	171	22-2110	154	22-5811	149, 177	22-7427	182	23-0002	221
21-7831	188	22-0088	171	22-2111	154	22-5840	177	22-7428	182	23-0043	518
21-7832	188	22-0089	171	22-2112	154	22-5844	176	22-7429	183	23-0049	203
21-7833	188	22-0090	171	22-2160	142	22-5845	177	22-7431	183	23-0050	203
21-7834	188	22-0091	171	22-2165	193	22-5849	177	22-7432	183	23-0051	203
21-7835	188	22-0092	171	22-2170	145	22-5850	174	22-7435	178	23-0052	203
21-7836	188	22-0093	171	22-2180	145	22-5855	174	22-7436	178	23-0053	203
21-7970	188	22-0094	171	22-2190	144	22-5856	174	22-7437	183	23-0054	203
21-7975	188	22-0095	171	22-2200	143	22-5860	174	22-7438	183	23-0065	220
21-7976	188	22-0096	171	22-3600	146	22-5865	174	22-7439	183	23-0073	203
21-7980	188	22-0097	171	22-3602	146	22-5868	176	22-7440	182, 183	23-0074	203
21-9010	200	22-0133	171	22-3603	146	22-5869	175	22-7500	517	23-0075	203
21-9050	154	22-0510	194	22-3604	146	22-5870	176	22-7502	517	23-0076	203
21-9099	155	22-1000	152	22-3700	193	22-5871	176	22-7503	517	23-0077	203
21-9101	155	22-1005	152	22-3702	193	22-5880	174	22-7506	517	23-0078	203
21-9102	155	22-1008	152	22-4610	193	22-5885	174	22-7508	432, 517	23-0080	203
21-9103	155	22-1029	154	22-4620	146, 192	22-5889	176	22-7511	517	23-0082	202
21-9104	155	22-1035	154	22-4624	192	22-5896	176	22-7512	517	23-0083	202
21-9114	155	22-1045	152	22-4631	192	22-5900	174	22-7910	148, 191	23-0900	623
21-9115	155	22-1047	152	22-4634	192	22-5901	175	22-7911	148, 191	23-1000	222
21-9116	155	22-1051	151	22-4700	193	22-5902	175	22-7912	148, 191	23-1010	222
21-9117	155	22-1053	151	22-4701	193	22-5903	175	22-7913	191	23-1012	222
21-9118	155	22-1055	151	22-4702	193	22-5904	175	22-7913KIT	191	23-1015	222
21-9120	155	22-1056	151	22-4720	187	22-5905	175	22-7914	191	23-1020	222
21-9121	155	22-1057	151	22-4725	188	22-5906	175	22-7914KIT	191	23-1022	222
21-9122	155	22-1060	151	22-4727	148, 188	22-5907	175	22-7921	189	23-1030	223
21-9137	163	22-1061	151	22-4731	199	22-5908	175	22-7922	189	23-1032	223
21-9138	163	22-1062	151	22-4739	199	22-5915	175	22-7923	189	23-1034	223
21-9139	163	22-1070	151	22-4740	199	22-5916	174	22-7930	191	23-2000	223
21-9140	163	22-1100	153	22-4741	199	22-5917	175	22-7931	191	23-2400	503
21-9141	163	22-1101	152	22-4745	198	22-5922	178	22-7932	191	23-2401	503
21-914											

SERIES #	PAGE										
23-5710	212	25-0444	410	26-2602	313	26-4099	91	26-4162	249	28-0552	231
23-5850	214	25-0457	407	26-2603	313	26-4100	91	26-4163	249	28-0554	231
23-5851	214	25-0550	409	26-2604	312	26-4101	91	26-4164	240	28-0555	231
23-5854	214	25-0570	409	26-3660	250	26-4102	91	26-4165	251	28-0557	231
23-5858	214	25-0571	409	26-3770	241	26-4103	91	26-4166	251	28-0558	231
23-5859	214	25-0572	100	26-3780	241	26-4105	249	26-4167	248	28-0559	231
23-5874	211	25-0573	410	26-3781	241	26-4106	249	26-4168	99, 252	28-0560	231
23-5900	223	25-0574	409	26-3850	241	26-4107	91	26-4169	99, 252	28-0561	231
23-5901	215	25-0575	408	26-3852	241	26-4107	249	26-4172	414	28-0562	231
23-5904	215	25-0579	407	26-3853	241	26-4108	249	26-4173	414	28-0563	231
23-5905	223	25-0580	409	26-3879	228	26-4112	252	26-4174	414	28-0564	231
23-5906	205	25-0581	409	26-3920	240	26-4113	251	26-4175	414	28-0565	231
23-5915	222	25-0582	407	26-3925	240	26-4114	92	26-4176	414	28-0566	231
23-5920	222	25-0583	407	26-3926	240	26-4115	564	26-4178	414	28-0567	231
23-5928	211	25-0584	407	26-3928	240	26-4116	564	26-4180	257	28-0568	231
23-5929	211	25-0585	407	26-3985	255	26-4117	564	26-4181	257	28-0569	231
23-5931	211	25-0600	410	26-3986	255	26-4118	564	26-4182	92, 250	28-0570	231
23-5950	210	25-0602	410	26-3990	255	26-4119	564	26-4185	249	28-0571	231
23-6015	224	25-1233	408	26-3991	255	26-4120	91	26-4191	255	28-0572	231
23-6020	224	25-1234	408	26-3999	254	26-4122	564	26-4196	246	28-0573	231
23-6021	224	25-1235	408	26-4000	254	26-4123	564	26-4201	342	28-0574	231
23-6200	222	25-1236	408	26-4001	254	26-4124	564	26-4205	99, 251	28-0575	231
23-6205	223	25-1237	408	26-4002	254	26-4125	91	26-4215	251	28-0576	231
23-6206	223	25-1241	407	26-4009	242	26-4126	91	26-5000	250	28-0577	231
23-6208	211	25-1347	96	26-4011	242	26-4129	248	26-5001	250	28-0578	231
23-6209	222	25-1348	412	26-4013	242	26-4130	248	26-5100	245	28-0579	231
23-6210	222	25-1350	410	26-4014	255	26-4131	248	26-5101	245	28-0580	231
23-6211	222	25-1353	410	26-4015	255	26-4134	249	26-5118	564	28-0601	230
23-6212	222	25-2002	411	26-4016	255	26-4135	257	26-5119	564	28-0602	230
23-6500	215	25-2003	411	26-4017	255	26-4136	256	26-5200	245	28-0603	230
23-6501	215	26-1000	122	26-4018	255	26-4137	257	26-5300	245	28-0604	230
23-6502	215	26-1000	251	26-4019	254	26-4138	257	26-5400	251	28-0605	230
23-6610	215	26-1002	251	26-4037	243	26-4139	248	26-5500	245	28-0606	230
23-6611	215	26-1003	237	26-4038	243	26-4140	256	26-5600	245	28-0607	230
23-6612	215	26-1600	251	26-4039	236	26-4144	103	26-6000	98	28-0608	230
24-1125	140	26-1800	247	26-4040	255	26-4145	564	26-6001	98	28-0609	230
24-1126	140	26-1801	247	26-4041	255	26-4146	564	26-6002	98	28-0610	230
24-1127	140	26-1802	247	26-4042	255	26-4147	250	26-6003	98	28-0611	230
24-1128	140	26-1803	247	26-4043	255	26-4148	91	26-6006	99	28-0612	230
24-1129	141	26-1804	247	26-4055	291	26-4149	251	26-6008	46, 316	28-0613	230
24-1130	141	26-1805	247	26-4057	291	26-4150	414	26-6009	45	28-0614	230
24-1131	141	26-1806	247	26-4073	246	26-4151	250	26-6010	45	28-0615	230
24-1132	141	26-1807	247	26-4079	246	26-4152	250	28-0422	406	28-0616	230
24-1133	141	26-1808	247	26-4080	246	26-4154	250	28-0423	406	28-0617	230
24-1134	141	26-1809	247	26-4081	246	26-4155	103	28-0425	406	28-0618	230
24-1135	141	26-1810	247	26-4082	246	26-4156	248, 249	28-0440	406	28-0619	230
24-1136	141	26-1811	247	26-4083	246	26-4157	248	28-0460	406	28-0620	230
24-1137	141	26-1812	247	26-4086	246	26-4158	91	28-0472	406	28-0621	230
25-0000	410	26-1813	247	26-4089	246	26-4159	91	28-0540	231	28-0622	230
25-0001	410	26-2600	313	26-4094	246	26-4160	254	28-0550	231	28-0623	230
25-0440	409	26-2601	315	26-4098	246	26-4161	254	28-0551	231	28-0624	230

SERIES #	PAGE										
28-0625	230	28-0731	229	28-5873	235	29-0068	515	29-4702	343	29-6005	338
28-0626	230	28-0732	229	28-5874	235	29-0069	515	29-4703	343	29-6010	337
28-0627	230	28-0733	229	28-5875	235	29-0100	518	29-4704	343	29-6012	337
28-0628	230	28-0734	229	28-5876	235	29-0101	519	29-4705	343	29-6013	337
28-0629	230	28-0736	229	28-5877	235	29-0102	519	29-4706	343	29-6014	337
28-0630	230	28-0737	229	28-5878	235	29-1300	340	29-4707	343	29-6015	337
28-0631	230	28-0739	229	28-5879	235	29-1301	340	29-4708	343	29-6016	339
28-0660	233	28-0740	229	28-5880	235	29-1302	340	29-4709	343	29-6017	339
28-0661	233	28-0741	229	28-5881	235	29-1303	340	29-4710	343	29-6020	336
28-0662	233	28-0751	229	28-5882	235	29-1304	340	29-4711	343	29-6021	336
28-0663	233	28-0752	229	28-6001	23	29-1310	344	29-4714	343	29-6022	336
28-0664	233	28-0753	229	28-6005	23	29-1311	344	29-4715	343	29-6023	336
28-0665	233	28-0754	229	28-6006	23	29-1400	346	29-4720	343	29-6024	336
28-0666	233	28-0755	229	29-0003	513	29-1401	346	29-4721	343	29-6025	339
28-0667	233	28-0757	229	29-0004	513	29-1402	346	29-4726	347	29-6030	337
28-0668	233	28-0758	229	29-0005	512	29-1404	346	29-4727	347	29-6031	337
28-0669	233	28-0759	229	29-0006	512	29-1405	346	29-4728	347	29-6032	337
28-0670	233	28-1000	235	29-0007	512	29-1408	346	29-4730	344	29-6035	336
28-0671	233	28-1980	405	29-0008	513	29-1499	311	29-4731	340	29-6036	336
28-0672	233	28-1990	402	29-0009	514	29-1501	311	29-4732	340	29-6037	336
28-0673	233	28-1991	402	29-0010	433, 514	29-1502	311	29-4738	344	29-6040	338
28-0674	233	28-1992	404	29-0012	433, 514	29-1503	311	29-4739	344	29-6041	338
28-0675	233	28-1994	402	29-0013	515	29-1504	311	29-4740	309	29-6042	338
28-0676	233	28-1996	404	29-0014	515	29-1505	311	29-4741	309	29-6043	338
28-0677	233	28-1997	403	29-0015	516	29-1520	311	29-4744	309	29-6044	338
28-0678	233	28-1998	403	29-0016	516	29-1521	311	29-4749	309	29-6045	338
28-0679	233	28-2002	404	29-0017	513	29-1522	311	29-4755	309	29-6047	337
28-0680	233	28-2003	404	29-0019	513	29-1523	311	29-4756	309	29-6048	337
28-0681	230	28-2004	404	29-0020	514	29-1524	311	29-4758	245	29-6049	337
28-0682	231	28-2005	403	29-0021	513	29-1602	308	29-4763	345	29-6050	337
28-0686	228	28-2006	403	29-0022	513	29-1605	310	29-4764	345	29-6051	337
28-0687	228	28-2007	405	29-0026	512	29-1652	308	29-4765	345	29-6052	337
28-0688	231	28-2008	405	29-0027	512	29-1655	308	29-4777	329	29-6060	339
28-0700	229	28-2009	405	29-0028	512	29-2000	578	29-4778	329	29-6070	336
28-0705	229	28-2114	287, 288	29-0029	512	29-2503	341	29-4780	310	29-6071	336
28-0712	229	28-2115	236	29-0030	514	29-2504	341	29-4781	346	29-6072	336
28-0713	229	28-2116	236	29-0032	342	29-2505	316, 341	29-4782	310	29-6073	336
28-0714	229	28-2118	237	29-0035	516	29-2601	338	29-4783	310	29-6074	336
28-0715	229	28-3010	235	29-0040	515	29-2602	338	29-4790	342	29-6075	336
28-0716	229	28-3011	235	29-0045	513	29-2603	338	29-4811	346	29-6100	341
28-0717	229	28-3012	235	29-0046	513	29-2605	337	29-4812	346	29-6105	344
28-0718	229	28-3013	235	29-0047	513	29-2606	340	29-4840	312	29-6110	343
28-0719	229	28-3014	235	29-0048	513	29-2710	314	29-4841	312	29-6111	343
28-0720	229	28-3015	235	29-0049	513	29-2711	314	29-4842	312	29-6112	343
28-0721	229	28-4000	230	29-0050	515	29-2712	314	29-4848	312		



SERIES #	PAGE										
29-7201	339	31-2440	268	31-5932	275	31-7626	276	34-2013	110, 475	34-2257	283
29-7202	339	31-2451	268	31-5954	275	31-7627	277	34-2014	110, 475	34-2260	285
29-7600	347	31-2462	268	31-5966	275	31-7629	277	34-2015	475	34-2261	285
29-7601	347	31-2484	268	31-5970	274	31-7636	277	34-2016	475	34-2262	284
29-7602	347	31-2496	268	31-5982	274	31-7715	279	34-2100	290	34-2263	284
29-7603	347	31-3720	269	31-5994	274	31-8002	271	34-2103	290	34-2266	287
29-7700	347	31-3731	269	31-6191	275	31-8004	271	34-2110	290	34-2267	287
29-7701	347	31-3742	269	31-6200	275	31-8008	271	34-2113	290	34-2268	287
29-7702	347	31-3754	269	31-6222	275	31-8010	271	34-2114	290	34-2270	285
29-7703	347	31-3840	267	31-6244	275	31-8014	271	34-2115	290	34-2271	284
29-7704	347	31-3850	267	31-6256	275	31-8016	271	34-2130	283, 284, 291	34-2273	284
31-0271	268	31-4581	275	31-6371	275	31-8026	272	34-2131	283, 284, 291	34-2274	284
31-0280	268	31-4590	275	31-6380	275	31-8028	272	34-2132	284, 291	34-2277	284
31-0291	268	31-4612	275	31-6402	275	31-8032	272	34-2132	291	34-2279	285
31-0302	268	31-4634	275	31-6424	275	31-8034	272	34-2156	282, 283, 284	34-2280	285
31-0314	268	31-4646	275	31-6436	275	31-8038	272	34-2157	282, 284	34-2281	285
31-0590	269	31-4660	274	31-6450	273	31-8040	272	34-2158	282, 285	34-2283	285
31-0602	269	31-4682	274	31-6472	273	31-8044	272	34-2159	284	34-2286	282, 284
31-0680	269	31-4704	274	31-6494	273	31-8046	272	34-2175	289	34-2289	284
31-0690	269	31-4900	275	31-6506	273	31-8048	271	34-2190	290	34-2293	283
31-0702	269	31-4912	275	31-6790	277	31-8050	271	34-2207	290	34-2294	283
31-0714	269	31-4924	275	31-6802	277	31-8052	271	34-2208	290	34-2295	284
31-1110	268	31-4936	275	31-6814	277	31-8054	271	34-2209	289	34-2297	284
31-1120	268	31-4940	274	31-6828	277	31-8056	270	34-2210	289	34-2298	291
31-1131	268	31-4952	274	31-6833	279	31-8060	270	34-2211	284	34-2299	290
31-1142	268	31-4964	274	31-6840	278	31-8062	270	34-2212	284	34-2302	25
31-1153	268	31-5039	594	31-6852	278	31-8064	270	34-2213	283, 289	34-2303	290
31-1164	268	31-5051	274	31-7000	276	31-8066	270	34-2214	289	34-2304	290
31-1176	268	31-5060	274	31-7012	276	31-9910	278	34-2215	282, 288	34-2305	475
31-1271	268	31-5082	274	31-7034	276	33-6029	135	34-2217	290	34-2307	285
31-1280	268	31-5104	274	31-7046	276	33-6032	135	34-2219	289	34-2308	284
31-1291	268	31-5116	274	31-7050	276	33-6350	135	34-2220	288	34-2309	284
31-1302	268	31-5120	273	31-7106	270	33-6355	135	34-2224	243	34-2310	289
31-1313	268	31-5132	273	31-7142	276	33-8301	277	34-2229	257	34-2319	284
31-1324	268	31-5144	273	31-7154	276	33-8302	277	34-2231	257	34-2325	284
31-1431	269	31-5241	274	31-7166	276	33-9220	267	34-2232	257	34-2327	284
31-1440	269	31-5250	274	31-7202	276	33-9235	278	34-2233	243, 257	34-2346	284
31-1451	269	31-5272	274	31-7214	276	33-9240	267	34-2234	243, 257	34-2347	284
31-1462	269	31-5294	274	31-7252	276	33-9500	279	34-2239	473	34-2351	291
31-1473	269	31-5306	274	31-7274	276	33-9501	279	34-2240	283	34-2352	291
31-1484	269	31-5310	273	31-7286	276	33-9502	279	34-2241	283	34-2353	291
31-1496	269	31-5332	273	31-7290	276	33-9503	279	34-2242	282	34-2354	288
31-2117	269	31-5354	273	31-7336	277	33-9810	269	34-2243	282	34-2355	288
31-2118	269	31-5580	275	31-7420	276	34-1000	475	34-2246	473	34-2359	291
31-2120	269	31-5592	275	31-7432	276	34-1010	286	34-2247	473	34-2364	289
31-2121	269	31-5614	275	31-7454	276	34-1012	286	34-2248	473	34-2370	290
31-2132	268	31-5626	275	31-7466	276	34-2000	475	34-2249	473	34-2375	282, 288
31-2141	273	31-5630	274	31-7470	276	34-2001	475	34-2250	284	34-2376	288
31-2142	273	31-5642	274	31-7576	277	34-2002	475	34-2251	284	34-2377	288
31-2143	273	31-5901	275	31-7612	277	34-2008	475	34-2254	284	34-2402	288
31-2430	268	31-5910	275	31-7624	277	34-2010	475	34-2255	282	34-3000	292

SERIES #	PAGE										
34-3002	292	35-2610	299	35-5600	303	36-2597	263	36-3501	260	37-0366	324
34-4003	289	35-2611	298	35-5602	303	36-2600	258	36-3502	260	37-0367	324
34-4006	289	35-2612	303	35-5609	304	36-2601	258	36-3503	260	37-0409	327
34-4007	289	35-2613	298	35-5610	303	36-2602	258	36-3504	260	37-1202	327
34-6100	280	35-2614	299	35-5617	306	36-2603	258	36-3505	260	37-1220	327
34-6105	280	35-2615	298	35-5628	301	36-2604	258	36-3506	260	37-1240	327
34-6110	287	35-2616	295	35-5700	161	36-2609	263	36-3511	260	37-1241	327
34-6112	287	35-2617	295	36-1200	261	36-2640	262	36-3512	260	37-1552	321
34-6113	281	35-2620	298	36-1202	261	36-2641	262	36-3513	260	37-1553	321
34-6114	281	35-2621	298	36-1204	261	36-2642	262	36-3514	260	37-1554	321
34-6115	281	35-2622	298	36-1205	261	36-2643	262	36-3515	260	37-1555	321
34-6116	281	35-2625	299	36-1206	261	36-2644	262	36-3518	260	37-1600	320
34-6117	281	35-2626	299	36-1556	251	36-2645	261	36-3523	260	37-1601	320
34-6301	101, 228	35-2650	299	36-2540	262	36-2646	261	36-3524	260	37-1602	320
34-6302	228	35-2800	296	36-2541	262	36-2647	261	36-3525	260	37-1603	320
35-0140	305	35-2810	307	36-2542	262	36-2648	262	36-3526	260	37-1604	320
35-0300	305	35-2820	296	36-2543	262	36-2649	262	36-3527	260	37-1605	320
35-0425	299	35-2840	296	36-2545	262	36-2650	261	36-3528	260	37-1606	320
35-0705	304	35-2860	296	36-2546	262	36-2700	259	36-3529	260	37-1607	320
35-0800	170, 306	35-2880	296	36-2547	262	36-2701	259	36-3530	260	37-1608	320
35-0802	170, 306	35-2900	297	36-2548	262	36-2702	259	36-3532	260	37-1613	322
35-0805	170, 305	35-2902	296	36-2549	262	36-2703	259	36-3535	260	37-1614	322
35-0806	170, 305	35-2903	296	36-2550	258	36-2704	259	36-3536	260	37-1615	322
35-1086	295	35-2909	297	36-2551	258	36-2705	259	36-3537	260	37-1616	322
35-1087	295	35-2910	297	36-2552	258	36-2706	259	36-3538	260	37-1617	322
35-1094	294	35-2912	296	36-2553	258	36-2707	259	36-3542	260	37-1618	322
35-1095	295	35-2914	296	36-2554	258	36-2708	259	36-3543	260	37-1619	322
35-1200	301	35-2915	296	36-2555	258	36-2709	259	36-3544	260	37-1620	322
35-1234	293	35-2916	297	36-2556	258	36-2710	259	36-6500	261	37-1621	322
35-1237	280	35-2917	294	36-2557	258	36-2711	259	36-6501	261	37-1622	322
35-1520	302	35-2940	307	36-2559	258	36-2712	259	36-6502	261	37-1623	320
35-1522	302	35-2941	307	36-2560	258	36-2713	259	36-6510	261	37-1624	320
35-1524	302	35-2942	307	36-2561	258	36-2714	259	36-6511	261	37-1625	320
35-1526	302	35-2945	297	36-2563	258	36-2715	259	36-6512	261	37-1626	320
35-1528	302	35-2947	297	36-2564	258	36-2719	259	36-6513	261	37-1627	320
35-1529	302	35-2964	307	36-2565	258	36-2720	259	36-6520	261	37-1628	320
35-1797	302	35-2980	297	36-2566	258	36-2721	259	36-6521	261	37-1629	320
35-1798	302	35-2981	297	36-2567	258	36-2722	259	36-6522	261	37-1630	320
35-1803	302	35-2982	297	36-2570	258	36-2723	259	36-6531	261	37-1631	320
35-1812	300	35-2983	297	36-2571	258	36-2724	259	36-6532	261	37-1632	320
35-1813	300	35-2998	296	36-2572	258	36-2725	259	36-6550	261	37-1633	320
35-1814	300	35-2999	296	36-2573	258	36-2726	259	36-6551	261	37-1634	320
35-1817	300	35-5100	304	36-2574	258	36-2727	259	36-8000	264	37-1635	320
35-1818	301	35-5104	304	36-2580	258	36-2732	259	36-8630	264	37-1636	320
35-1821	301	35-5106	304	36-2581	258	36-2733	259	36-8			

SERIES #	PAGE										
37-2170	324	38-0004	66	38-4016	61	38-4069	61	38-5039	61	38-6031	60
37-2171	324	38-0011	66	38-4017	61	38-4070	61	38-5040	61	38-6032	60
37-2180	326	38-0012	66	38-4018	61	38-4071	61	38-5041	61	38-6033	60
37-5300	325	38-0100	63	38-4019	61	38-4072	61	38-5042	61	38-6034	60
37-5310	325	38-0101	63	38-4020	61	38-4073	61	38-5043	61	38-6035	60
37-5320	325	38-0102	63	38-4021	61	38-4074	61	38-5044	61	38-6036	60
37-5321	325	38-0106	63	38-4022	61	38-4076	61	38-5045	61	38-6037	60
37-5360	325	38-0107	63	38-4023	61	38-4078	61	38-5046	61	38-6038	60
37-5400	323	38-0108	63	38-4024	61	38-4082	61	38-5047	61	38-6050	67
37-5401	323	38-0189	65	38-4025	61	38-4084	61	38-5048	61	38-6051	67
37-5500	325	38-0190	75	38-4026	61	38-4086	61	38-5049	61	38-6052	67
37-5502	325	38-0192	75	38-4027	61	38-4088	61	38-5050	61	38-6053	67
37-5840	325	38-0193	75	38-4028	61	38-4092	61	38-5051	61	38-6054	67
37-5900	325	38-0194	75	38-4029	61	38-4093	61	38-5052	61	38-6060	67
37-5902	325	38-0907	63	38-4030	61	38-4094	61	38-5053	61	38-6061	67
37-7000	326	38-0908	63	38-4031	61	38-4096	61	38-5054	61	38-6062	67
37-7001	326	38-1000	74, 317	38-4032	61	38-4098	61	38-5055	61	38-6063	67
37-7002	326	38-1001	74	38-4033	61	38-5001	61	38-5056	61	38-6064	67
37-7003	326	38-1002	74, 317	38-4034	61	38-5002	61	38-5057	61	38-7000	69
37-7004	326	38-1003	74, 317	38-4035	61	38-5003	61	38-5058	61	38-7001	69
37-7071	326	38-1005	73	38-4036	61	38-5004	61	38-5059	61	38-7002	69
37-7072	326	38-1006	74	38-4038	61	38-5005	61	38-5060	61	38-7003	69
37-7073	326	38-1007	73	38-4039	61	38-5006	61	38-5061	61	38-7005	69
37-7600	477	38-1008	73	38-4040	61	38-5008	61	38-5062	61	38-7006	64
37-7601	477	38-1009	73	38-4041	61	38-5009	61	38-5063	61	38-7007	64
37-7846	279	38-1010	73	38-4042	61	38-5012	61	38-5064	61	38-7010	69
37-7856	279	38-1011	73	38-4043	61	38-5013	61	38-5065	61	38-7011	69
37-8330	279	38-1012	73	38-4044	61	38-5014	61	38-5066	61	38-7012	69
37-8336	279	38-1013	74	38-4045	61	38-5015	61	38-5067	61	38-7013	69
37-8500	256	38-1015	73	38-4046	61	38-5016	61	38-5068	61	38-7014	69
37-8501	256	38-1016	73	38-4048	61	38-5018	61	38-5069	61	38-7015	69
37-8502	256	38-3100	79	38-4049	61	38-5019	61	38-5070	61	38-7016	69
37-8503	256	38-3101	79	38-4050	61	38-5020	61	38-5071	61	38-7017	69
37-8504	256	38-3102	79	38-4051	61	38-5021	61	38-5072	61	38-7050	64
37-8505	256	38-3250	46	38-4052	61	38-5022	61	38-5073	61	38-7052	64
37-8506	256	38-3300	79	38-4053	61	38-5023	61	38-5074	61	38-7060	64
37-8507	256	38-4001	61	38-4054	61	38-5024	61	38-5075	61	38-7062	64
37-8508	256	38-4002	61	38-4055	61	38-5025	61	38-5076	61	38-7070	64
37-8509	256	38-4003	61	38-4056	61	38-5026	61	38-5077	61	38-7071	64
37-8510	256	38-4004	61	38-4057	61	38-5027	61	38-5078	61	38-7085	65
37-8600	256	38-4005	61	38-4058	61	38-5028	61	38-5079	61	38-7086	65
37-8601	256	38-4006	61	38-4059	61	38-5029	61	38-5080	61	38-7087	65
37-8602	256	38-4007	61	38-4060	61	38-5030	61	38-5082	61	38-7088	65
37-8603	256	38-4008	61	38-4061	61	38-5031	61	38-5084	61	38-7090	64
37-8790	279	38-4009	61	38-4062	61	38-5032	61	38-5086	61	38-7091	64
37-8792	279	38-4010	61	38-4063	61	38-5033	61	38-5088	61	38-7092	64
37-8794	279	38-4011	61	38-4064	61	38-5034	61	38-5092	61	38-7093	64
37-9000	236	38-4012	61	38-4065	61	38-5035	61	38-5093	61	38-7096	66
38-0000	66	38-4013	61	38-4066	61	38-5036	61	38-5094	61	38-7097	66
38-0001	66	38-4014	61	38-4067	61	38-5037	61	38-5096	61	38-7098	66
38-0003	66	38-4015	61	38-4068	61	38-5038	61	38-5098	61	38-7099	66

SERIES #	PAGE										
38-7100	64	38-7204	70	43-1274	7	45-1207	574	45-4080	416	45-8016	430
38-7101	64	38-7205	70	43-1275	7	45-1208	574	45-4081	416	45-8019	430
38-7104	64	38-7209	70	43-1276	7	45-2000	417	45-4082	416	45-8024	430
38-7105	64	38-7210	70	43-1277	7	45-2010	428	45-4083	416	45-8041	430
38-7109	66	38-7211	70	43-1279	7	45-2020	428	45-4084	416	45-8043	430
38-7112	65	38-7212	70	43-1280	19, 23, 25, 37, 105	45-2030	428	45-4085	416	45-8045	430
38-7113	65	38-8010	67			45-2040	428	45-4086	416	45-8046	430
38-7114	63	38-8012	67	43-1281	37	45-2060	426	45-4100	423	45-8047	430
38-7116	65	38-9006	77	43-1282	37, 105	45-2080	426	45-4140	424	45-8048	430
38-7117	65	38-9008	77	43-1283	17, 25, 37	45-2100	426	45-4141	424	45-8050	430
38-7118	65	38-9019	79	43-1284	37	45-2120	426	45-4142	424	45-8051	430
38-7120	62	38-9022	73	43-1286	37	45-2140	426	45-4143	424	45-8052	430
38-7121	65	38-9023	68	43-1288	34, 37	45-2160	426	45-4145	424	45-8060	431
38-7122	65	38-9024	65	43-1289	34, 37	45-2180	428	45-4146	424	45-8061	431
38-7125	65	38-9025	65	43-1300	31, 37	45-2200	426	45-4147	424	45-8062	431
38-7126	65	39-0626	95	43-1301	31, 37	45-2220	426	45-4148	424	45-8063	431
38-7130	62	39-1800	95	43-1302	37	45-2230	425	45-4149	424	45-8064	431
38-7131	62	39-1830	136	43-1303	37	45-2231	425	45-4150	424	45-8065	431
38-7133	62	39-1831	136	43-1304	37	45-2232	425	45-4152	424	45-8066	431
38-7134	62	39-1832	136	43-1305	37	45-2233	424	45-4153	424	45-8067	431
38-7140	67	39-1833	136	43-1306	37	45-2234	425	45-4154	424	45-8068	431
38-7141	67	39-2500	179	43-5120	421	45-2260	426	45-4155	428	45-8800	430
38-7142	67	39-2560	179	43-5121	421	45-2500	426	45-4160	427	45-8801	430
38-7143	67	39-2561	179	43-5122	421	45-2510	426	45-4162	427	45-8802	430
38-7144	67	39-2570	179	43-6380	577	45-2520	426	45-4163	427	45-8804	430
38-7154	67	39-2575	179	43-6400	577	45-2530	426	45-4179	428	46-0000	456
38-7155	68	39-2580	179	43-6410	577	45-3006	574	45-4997	429	46-0001	436
38-7156	68	39-2585	179	43-6420	577	45-3007	574	45-4998	429	46-0002	436
38-7160	68	39-2590	179	43-6421	421	45-3015	574	45-5000	429	46-0003	436
38-7161	68	39-2595	179	43-6422	421	45-4000	422	45-5002	429	46-0004	436
38-7162	68	41-4150	428	43-6423	421	45-4001	422	45-5004	429	46-0005	436
38-7163	68	41-4155	428	43-6424	421	45-4002	422	45-6400	420	46-0006	436
38-7165	68	41-4160	428	45-0130	429	45-4005	422	45-6401	420	46-0008	436
38-7167	68	41-4165	428	45-0135	429	45-4006	422	45-6402	420	46-0009	436
38-7170	69	43-0500	307	45-0150	417	45-4007	422	45-6404	420	46-0010	436
38-7171	69	43-0501	307	45-0151	417	45-4030	419	45-6405	420	46-0011	436
38-7172	69	43-0540	307	45-0312	428	45-4037	419	45-6410	420	46-0012	436
38-7188	62	43-0600	103	45-0320	420	45-4040	423	45-6411	420	46-0013	436
38-7189	62	43-0606	499	45-0321	420	45-4044	419	45-6412	420	46-0014	436
38-7191	62	43-0607	499	45-0322	420	45-4050	422	45-6414	420	46-0016	436
38-7192	62	43-0610	499	45-0323	420	45-4052	422	45-6420	421	46-0017	436
38-7193	62	43-1260	7	45-0324	420	45-4053	422	45-7119	419	46-0018	436
38-7194	62	43-1261	7	45-0326	420	45-4054	422	45-7120	419	46-0019	438
38-7195	60	43-1262	7	45-0330	420	45-4055	422	45-7990	429	46-0023	438
38-7196	60	43-1264	7	45-0334	420	45-4056	422	45-7995	429	46-0027	437
38-7197	60	43-1265	7	45-0400	421	45-4057	422, 423	45-8000	430	46-0035	439
38-7198	60	43-1266	7	45-0402	421	45-4058	422, 423	45-8001	430	46-0036	439
38-7201	70	43-1267	7	45-0403	421	45-4059	423	45-8003	430	46-0037	439
38-720											



SERIES #	PAGE										
46-0040	439	46-0524	443	46-2410	413	46-4028	461	46-7898	438	47-3140	484
46-0041	439	46-0526	443	46-2430	454	46-4029	461	46-7900	434	47-3150	485
46-0042	439	46-0528	443	46-2600	452	46-4030	450	46-7901	434	47-3151	485
46-0043	439	46-0530	443	46-2610	452	46-4035	449	46-7903	437	47-3152	485
46-0044	439	46-0535	443	46-2620	452	46-4040	65	46-7905	437	47-3153	485
46-0045	439	46-0536	443	46-2630	452	46-4050	460	46-8000	443	47-3154	485
46-0046	439	46-0537	443	46-2640	452	46-4051	460	46-8001	443	47-3155	485
46-0047	439	46-0538	443	46-2650	452	46-4052	460	46-8002	443	47-3156	485
46-0048	439	46-0539	446	46-2690	452	46-4053	460	46-8003	443	47-3200	482
46-0049	439	46-0541	445	46-2700	453	46-4545	222, 599	46-8004	443	47-3205	482
46-0050	439	46-0542	444	46-2710	453	46-4550	222, 599	46-8005	443	47-3210	482
46-0053	439	46-0543	444	46-2720	453	46-4555	222, 599	46-8007	443	47-3211	482
46-0054	439	46-0544	444	46-2730	453	46-5005	463	46-8050	610	47-3215	482
46-0055	437	46-0545	444	46-2740	453	46-5015	463	46-8055	610	47-3221	486
46-0056	437	46-0546	444	46-2750	453	46-5016	463	46-8140	434	47-3222	482
46-0057	455	46-0547	444	46-2790	453	46-5020	463	46-8142	434	47-3223	486
46-0058	447	46-0548	444	46-2850	462	46-5060	462	46-8150	434	47-3224	486
46-0059	447	46-0549	444	46-2900	455	46-5100	462	46-8152	434	47-3225	486
46-0060	437	46-1000	442	46-2905	455	46-5120	462	46-8160	434	47-3226	487
46-0061	437	46-1020	442	46-3030	455	46-5140	462	46-8162	434	47-3227	487
46-0062	455	46-1040	442	46-3050	456	46-5160	462	46-8163	435	47-3228	487
46-0063	445	46-1060	442	46-3057	456	46-5200	462	46-8164	435	47-3229	487
46-0064	462	46-1080	442	46-3060	455	46-5320	450	46-8170	434	47-3230	482
46-0066	445	46-1100	442	46-3070	72, 446	46-6016	441	46-9003	80, 446	47-3231	619
46-0067	445	46-1140	442	46-3080	449	46-7001	441	46-9005	449	47-3232	487
46-0068	445	46-1200	442	46-3085	445	46-7002	441	46-9006	462	47-3235	482
46-0070	460	46-1260	442	46-3480	447	46-7003	441	46-9010	449	47-3236	482
46-0170	444	46-1500	446	46-3482	463	46-7004	441	47-1026	622	47-3240	485
46-0175	444	46-1503	446	46-3483	463	46-7006	441	47-2304	476	47-3241	485
46-0180	444	46-1520	445	46-3990	454	46-7007	441	47-2305	476	47-3242	485
46-0380	454	46-1521	445	46-3994	461	46-7008	441	47-2306	476	47-3243	485
46-0399	442	46-1522	445	46-3995	83	46-7009	441	47-2307	476	47-3244	485
46-0400	442	46-1523	445	46-3997	83	46-7010	441	47-2308	476	47-3245	484
46-0401	442	46-1524	445	46-4000	454	46-7011	440	47-2309	476	47-3246	483
46-0402	442	46-1525	445	46-4002	461	46-7012	440	47-2560	110	47-3247	483
46-0403	442	46-1526	445	46-4004	454	46-7013	440	47-2580	110, 477	47-3250	481
46-0404	456	46-2070	448	46-4005	83	46-7014	440	47-2590	110, 477	47-3255	481
46-0405	456	46-2071	448	46-4006	80, 446	46-7017	440	47-2600	110, 477	47-3257	481
46-0406	449	46-2082	444	46-4007	83	46-7018	441	47-2608	110, 477	47-3260	484
46-0499	458	46-2083	444	46-4009	447	46-7020	441	47-2610	110, 477	47-3261	485
46-0500	459	46-2084	444	46-4010	459	46-7021	440	47-2701	474	47-3262	485
46-0501	459	46-2085	444	46-4011	447	46-7190	435	47-2712	476	47-3263	485
46-0503	459	46-2086	444	46-4013	81	46-7291	435	47-3065	519	47-3264	485
46-0504	458	46-2087	444	46-4013	458	46-7490	435	47-3067	519	47-3265	484
46-0508	80, 458	46-2088	444	46-4014	81, 458	46-7590	435	47-3068	433, 519	47-3266	483
46-0509	458	46-2089	444	46-4015	448	46-7892	435	47-3085	418	47-3267	484
46-0513	80, 458	46-2090	444	46-4016	448	46-7893	435	47-3087	418	47-3270	482
46-0515	83, 446	46-2091	444	46-4017	80	46-7894	435	47-3088	418	47-3271	483
46-0516	82, 446	46-2092	444	46-4020	461	46-7895	438	47-3100	619	47-3274	482
46-0520	443	46-2093	444	46-4021	451	46-7896	438	47-3120	484	47-3275	482
46-0522	443	46-2400	413	46-4025	461	46-7897	438	47-3130	484	47-3276	482

SERIES #	PAGE										
47-3280	481	47-4091	418, 548	47-4195	468	47-5033	507	47-5302	480	48-1806	457
47-3281	481	47-4092	418	47-4196	468	47-5034	507	47-5304	480	48-2300	598
47-3282	481	47-4093	418, 548	47-4198	468	47-5037	508	47-5305	480	48-3000	569
47-3285	481	47-4094	469, 548	47-4200	467	47-5038	510	47-5306	480	48-4000	93
47-3290	481	47-4095	469	47-4201	468	47-5039	508	47-5307	480	48-7500	415
47-3291	481	47-4096	469	47-4203	467	47-5041	504	47-5308	480	48-7510	415
47-3297	481	47-4097	469	47-4208	468	47-5042	504	47-5309	480	48-7512	415
47-3299	483	47-4098	548	47-4213	466	47-5043	504	47-5310	480	48-7514	81, 414
47-3300	483	47-4099	548	47-4215	466	47-5044	504	47-5312	480	48-7520	414
47-3301	483	47-4101	418	47-4216	418, 466, 548	47-5047	507	47-5324	480	48-7525	298
47-3302	483	47-4104	469	47-4218	469	47-5052	509	47-6010	418	48-7526	298
47-3380	483	47-4106	466	47-4220	470	47-5053	506	47-6011	418	48-7535	414
47-3384	484	47-4108	466	47-4221	464	47-5054	506	47-7000	478	48-7537	413
47-3385	483	47-4109	469	47-4222	465	47-5055	505	47-7006	478	48-7540	415
47-3970	469	47-4111	466	47-4223	465	47-5056	505	47-7011	478	48-7550	415
47-3971	469	47-4119	466	47-4224	466	47-5057	509	47-8002	237	49-0995	523
47-3972	469	47-4122	92	47-4225	466	47-5058	505	47-8014	237	49-0996	523
47-3974	469	47-4123	471	47-4233	476	47-5061	509	47-8016	237	49-0997	523
47-3975	469	47-4127	470	47-4235	465	47-5160	508	47-8900	625	49-0998	523
47-4008	474	47-4128	470	47-4399	472	47-5164	508	47-8910	625	49-1000	522
47-4019	474	47-4129	470	47-4402	472	47-5215	511	47-8911	625	49-1001	522
47-4020	474	47-4132	470	47-4404	472	47-5216	511	47-8920	625	49-1002	522
47-4021	474	47-4133	470	47-4405	472	47-5219	511	47-8921	625	49-1003	522
47-4022	474	47-4135	469	47-4406	472	47-5220	511	47-8922	625	49-1004	522
47-4023	474	47-4137	504	47-4407	472	47-5222	511	47-8930	625	49-1005	522
47-4024	474	47-4140	478	47-4408	472	47-5223	511	48-1000	93	49-1006	522
47-4025	474	47-4141	470, 476	47-4409	472	47-5230	510	48-1010	93	49-1007	522
47-4033	466, 467	47-4142	470, 476	47-4752	466, 469	47-5231	510	48-1020	93	49-1008	522
47-4038	469	47-4143	476	47-4753	469	47-5235	510	48-1032	93	49-1010	522
47-4039	469	47-4144	476	47-4768	471	47-5236	510	48-1034	93	49-1011	522
47-4040	467	47-4145	475	47-4769	475	47-5237	510	48-1035	93	49-1012	522
47-4041	467	47-4146	475	47-4775	471	47-5240	511	48-1036	227	49-1013	522
47-4042	467	47-4147	470, 474	47-4993	470	47-5241	511	48-1043	227	49-1014	522
47-4043	467	47-4148	470, 474	47-4994	470	47-5242	508	48-1044	227	49-1018	522
47-4045	467	47-4149	474	47-4995	470	47-5243	509	48-1045	227	49-3002	523
47-4046	467	47-4150	474	47-4999	466	47-5260	503	48-1046	227	49-3003	523
47-4048	467	47-4156	472	47-5007	503	47-5261	503	48-1047	227	49-3004	523
47-4049	467	47-4160	172	47-5008	503	47-5262	503	48-1048	227	49-3006	523
47-4050	469	47-4161	172	47-5009	503	47-5263	503	48-1049	227	49-3008	523
47-4051	469	47-4162	172	47-5012	503	47-5264	503	48-1050	94	49-4001	521
47-4052	469	47-4163	172	47-5013	503	47-5265	503	48-1060	94	49-4002	521
47-4054	469	47-4164	172	47-5014	503	47-5266	503	48-1065	94	49-4003	521
47-4057	548	47-4165	172	47-5015	503	47-5267	503	48-1067	93	49-4004	521
47-4064	469	47-4166	172	47-5020	484	47-5268	503	48-1350	92	49-4005	521
47-4069	418	47-4172									

SERIES #	PAGE										
49-4050	521	49-7235	524	50-4209	522	52-0904	536	52-5416	535	53-1025	98
49-4060	521	49-7240	524	50-4220	521	52-0905	536	52-5420	535	53-1026	98
49-4070	521	49-7245	524	50-4222	521	52-0906	536	52-5425	535	53-1027	98
49-4080	521	49-7246	524	50-4223	521	52-0907	536	52-5430	535	53-1028	98
49-4100	521	49-7251	524	50-4224	521	52-0908	536	52-5440	538	53-1029	98
49-4120	521	50-1000	522	50-4225	521	52-0909	536	52-5450	538	53-1030	98
49-4140	521	50-1001	522	50-4226	521	52-0910	536	52-5470	535	53-1031	98
49-4200	522	50-1002	522	50-4227	521	52-1011	539	52-5500	535	53-1032	98
49-4201	522	50-1003	522	51-0000	533	52-1012	168, 539	52-5501	535	53-1033	98
49-4202	522	50-1004	522	51-0560	306	52-1025	537	52-5502	535	53-1034	98
49-4203	522	50-1005	522	51-0565	306	52-1026	537	52-5503	535	53-1035	98
49-4204	522	50-1006	522	51-0569	306	52-1027	537	52-5504	535	53-1200	229
49-4205	522	50-1007	522	51-0950	317	52-1028	537	52-5505	535	53-1201	229
49-4206	522	50-1008	522	51-0951	317	52-1029	537	52-5506	535	53-1203	229
49-4207	522	50-1010	522	51-0952	317	52-1030	537	52-5507	535	53-1206	229
49-4208	522	50-1011	522	51-1000	224	52-1031	537	52-5508	535	53-1207	229
49-4209	522	50-1012	522	51-2005	527	52-1032	537	52-9500	169, 253	53-1208	229
49-4220	521	50-1013	522	51-2034	531	52-1034	538	52-9501	253	53-1209	229
49-4221	521	50-1014	522	51-2036	531	52-1035	539	52-9502	253	53-1210	229
49-4222	521	50-1015	522	51-2037	530	52-1036	539	52-9504	253	53-1211	229
49-4223	521	50-1016	522	51-2075	527	52-1037	534	52-9505	253	53-1212	229
49-4224	521	50-1018	522	51-2076	527	52-1038	534	52-9506	253	53-1213	229
49-4225	521	50-1020	522	51-2077	530	52-1039	534	52-9660	169, 253	53-1216	229
49-4226	521	50-1022	522	51-2089	530	52-1040	534	53-0200	79	53-1400	94
49-4227	521	50-4001	521	51-2096	533	52-1041	534	53-0201	79	53-1402	94
49-4230	520	50-4002	521	51-2097	532	52-1042	534	53-0202	79	53-1406	94
49-4300	525	50-4003	521	51-2098	532	52-1043	534	53-0203	79	53-1409	99
49-6000	523	50-4004	521	51-2105	529	52-1045	536	53-0215	79	53-1412	99
49-6001	523	50-4005	521	51-2106	529	52-1046	536	53-0601	90	53-1425	99
49-6002	523	50-4006	521	51-2108	529	52-1054	536	53-0603	90	53-1442	94
49-6003	523	50-4008	521	51-2109	529	52-1055	536	53-0700	256	53-1725	97
49-6004	523	50-4010	521	51-2110	529	52-1056	536	53-1000	98	53-1726	97
49-6005	523	50-4020	521	51-2111	529	52-1057	536	53-1001	98	53-1905	284, 291
49-6006	523	50-4030	521	51-2112	529	52-1058	536	53-1002	98	53-2800	81, 457
49-6007	523	50-4040	521	51-4060	532	52-1059	536	53-1003	98	53-2801	81
49-6008	523	50-4050	521	51-4061	532	52-1060	536	53-1004	98	53-6200	80, 457
49-6010	523	50-4060	521	51-4062	532	52-1061	539	53-1005	98	53-8030	463
49-6011	523	50-4070	521	51-4063	533	52-1062	536	53-1006	98	53-8070	457
49-6012	523	50-4080	521	51-4068	528	52-1063	536	53-1007	98	53-9326	450
49-6013	523	50-4100	521	51-4069	528	52-1065	537	53-1008	98	54-0500	548
49-6014	523	50-4120	521	51-4072	528	52-1066	538	53-1009	98	54-0801	565, 597
49-6016	523	50-4140	521	51-4074	527	52-1070	538	53-1010	98	54-0802	565
49-6018	523	50-4200	522	51-4075	527	52-1080	537	53-1011	98	54-0900	218
49-7200	524	50-4201	522	51-4076	526	52-5140	537	53-1012	98	54-1100	568
49-7210	524	50-4202	522	51-4080	528	52-5400	535	53-1013	98	54-1101	568
49-7211	524	50-4203	522	51-4081	528	52-5401	535	53-1014	98	54-1104	566
49-7212	524	50-4204	522	51-4082	528	52-5406	535	53-1015	98	54-1105	566
49-7213	524	50-4205	522	51-4083KIT	528	52-5408	535	53-1021	98	54-1108	566
49-7220	524	50-4206	522	51-4090	527	52-5410	535	53-1022	98	54-1109	566
49-7221	524	50-4207	522	52-0902	536	52-5412	535	53-1023	98	54-1112	566
49-7230	524	50-4208	522	52-0903	536	52-5414	535	53-1024	98	54-1113	566

SERIES #	PAGE										
54-1115	549	54-4034	576	54-4462	221, 516	54-5605	177	55-2556	413	56-7647	585
54-1117	549	54-4035	572	54-4463	511	54-5802	180	55-2557	413	56-7648	585
54-1118	549	54-4036	173, 572	54-4468	221	54-5803	180	55-2558	413	56-7649	585
54-1119	549	54-4037	173, 572	54-4470	220	54-7000	566	55-2559	413	56-7650	585
54-1120	566	54-4038	173, 572	54-4478	220	54-8000	46	55-2560	413	56-7703	580
54-1122	549	54-4039	575	54-4479	220	54-8020	572	55-2561	413	56-7704	580
54-1200	566	54-4050	577	54-4490	220	54-8021	572	55-2622	412	56-7711	582
54-1201	566	54-4055	576	54-4491	220	54-8025	173	55-2623	412	56-7712	582
54-1202	564	54-4060	576	54-4492	220	54-8026	173	55-2722	412	56-7713	582
54-1784	568	54-4097	225	54-4493	220	54-8027	173	55-2723	412	56-7715	583
54-1785	568	54-4200	307	54-4520	220	54-8030	572	55-2922	412	56-7800	583
54-1789	569	54-4392	217	54-4530	559	54-8031	572	55-2923	412	56-7804	583
54-1800	568	54-4393	217	54-4535	190, 553	54-8035	572	55-3022	412	56-7805	583
54-1805	569	54-4394	217	54-4536	190, 553	54-8036	572	55-3023	412	56-7806	583
54-1810	569	54-4395	217	54-4537	190, 553	54-8041	173, 429	55-3122	412	56-7807	583
54-1815	569	54-4397	217	54-4538	190, 553	54-8042	173, 429	55-3123	412	56-7830	581
54-1817	569	54-4400	218	54-4560	565, 597	54-8043	173, 429	55-3222	412	56-7831	581
54-1818	569	54-4401	218	54-4566	547	54-8070	570	55-3223	412	56-7832	581
54-1819	569	54-4402	217	54-4567	547	54-8071	570	55-3230	412	56-7833	581
54-1880	567	54-4403	217	54-4568	547	54-8072	570	55-3322	412	56-7834	579
54-1888	568	54-4404	218	54-4569	547	54-8075	571	55-3335	412	56-7838	581
54-1890	567	54-4405	218	54-4581	547	54-8076	571	55-3336	412	56-7850	580
54-1891	567	54-4407	218	54-4600	573	54-8077	571	55-3337	412	56-7903	579
54-1892	567	54-4408	218	54-4700	219	54-8078	571	55-3340	411	56-7904	579
54-1894	568	54-4411	195	54-4710	219	54-8080	571	56-0805	586	56-7905	579
54-1895	568	54-4412	195, 570	54-4720	219	54-8081	571	56-0806	586	56-7906	579
54-1896	568	54-4413	195	54-4730	219	54-8082	571	56-0807	586	56-8000	586
54-1900	567	54-4414	195, 570	54-4740	219	54-8083	571	56-0809	586	56-8001	587
54-1901	567	54-4415	571	54-4750	219	54-8089	571	56-7006	587	56-8010	586
54-1902	567	54-4416	570	54-4760	219	54-8090	571	56-7007	587	56-8014	586
54-1904	567	54-4417	570	54-4770	219	54-9000	150	56-7100	587	56-8018	586
54-1905	567	54-4418	570	54-4780	219	54-9002	150	56-7101	587	56-8022	586
54-1906	567	54-4425	216	54-4790	219	54-9010	173	56-7102	587	56-8030	586
54-1910	567	54-4427	173	54-4800	219	54-9012	173	56-7130	587	56-9000	587
54-1911	567	54-4430	216	54-4810	219	55-2401	413	56-7131	587	56-9001	587
54-1912	567	54-4431	573	54-4820	219	55-2402	413	56-7140	587	57-0400	591
54-2520	195	54-4432	195, 573	54-4830	219	55-2403	413	56-7601	586	57-0420	82, 591
54-4000	571	54-4433	195, 573	54-4840	219	55-2407	413	56-7603	586	57-0430	591
54-4002	571	54-4435	573	54-4850	219	55-2522	412	56-7605	586	57-0440	591
54-4004	571	54-4439	218	54-4860	219	55-2523	412	56-7606	586	57-0450	595
54-4006	571	54-4440	575	54-4870	219	55-2540	411	56-7607	427	57-0451	595
54-4008	571	54-4444	220	54-5005	428	55-2541	411	56-7613	584	57-0570	593
54-4010	383, 577	54-4445	173	54-5020	574	55-2542	411	56-7615	584	57-0571	593
54-4011	577	54-4447	218	54-5022	574	55-2543	411	56-7618	584	57-0572	593
54-4015	572	54-4450	216	54							



SERIES #	PAGE										
57-0691	574, 598	57-6174	590	57-7625	596	58-2702	623	59-0772	614	59-2105	77, 624
57-5015	592	57-6178	590	57-7631	597	58-2703	623	59-0773	451, 616	59-2110	77, 624
57-5020	594	57-6180	589	57-7635	591	58-2704	623	59-0774	451, 616	59-2115	77, 624
57-5025	592	57-6181	589	57-7636	591	58-2705	624	59-0779	613	59-2500	58, 613
57-5030	82, 591	57-6182	588	57-7640	72, 82, 594	58-2799	617	59-0780	609	59-2600	58, 613
57-5035	592	57-6183	588	57-7657	596	58-2800	617	59-0781	607	59-2700	342
57-5042	592	57-6184	588	57-7658	596	58-2805	618	59-0790	608	59-3000	53, 59
57-6000	598	57-6185	588	57-7660	82, 593	59-0300	616	59-0793	607	59-3002	59
57-6001	598	57-6187	588	57-7770	549	59-0400	615	59-0794	608	61-0517	319
57-6002	598	57-6188	588	57-9200	222, 598	59-0402	614	59-0795	608	61-0518	319
57-6013	82, 595	57-6189	588	58-1030	102	59-0403	614	59-0797	608	61-0519	319
57-6015	595	57-6190	588	58-1400	236	59-0404	614	59-0798	608	61-0535	319
57-6016	595	57-6191	588	58-1412	406	59-0405	614	59-0800	615	61-0536	319
57-6017	595	57-6192	588	58-2200	236	59-0406	614	59-0804	614	61-0537	319
57-6021	595	57-6193	588	58-2400	236	59-0410	611	59-0805	614	61-0538	319
57-6025	591	57-6194	589	58-2410	237	59-0411	611	59-0806	614	61-0540	319
57-6026	591	57-6195	589	58-2422	102	59-0412	611	59-0807	615	61-0544	319
57-6027	591	57-6196	589	58-2423	102	59-0470	612	59-0808	615	61-0547	317
57-6028	591	57-6197	589	58-2430	101	59-0472	610	59-0809	614	61-0548	317
57-6029	591	57-6198	589	58-2432	101	59-0473	611	59-0810	615	61-0552	319
57-6030	591	57-6200	590	58-2434	101, 228	59-0475	611	59-0811	615	61-0554	319
57-6031	591	57-6201	590	58-2436	101	59-0476	612	59-0812	615	61-1331	49
57-6032	591	57-6250	593	58-2438	103	59-0482	611	59-0813	615	61-1332	49
57-6033	591	57-6260	593	58-2439	250	59-0484	623	59-0814	615	61-1333	49
57-6037	596	57-6280	597	58-2440	457, 516	59-0487	610	59-0815	615	61-1335	49
57-6038	596	57-6281	597	58-2450	236	59-0488	59, 623	59-0901	617	61-1336	49
57-6040	593	57-7302	590	58-2452	236	59-0489	611	59-0903	610	61-1510	51
57-6041	593	57-7303	590	58-2454	236	59-0550	609	59-0905	624	61-1520	51
57-6042	593	57-7304	590	58-2456	236	59-0555	609	59-0906	534, 622	61-1530	51
57-6043	593	57-7305	590	58-2462	525	59-0561	609	59-0961	612	61-1540	51
57-6050	592	57-7401	590	58-2465	525	59-0562	609	59-1000	53, 59	61-1550	51
57-6052	592	57-7403	590	58-2470	525	59-0563	610	59-1001	55	61-1555	51
57-6060	592	57-7405	339	58-2500	622	59-0564	610	59-1002	55	61-1556	51
57-6062	592	57-7406	339	58-2501	627	59-0565	609	59-1038	270	61-1557	51
57-6072	592	57-7500	594	58-2502	627	59-0645	608	59-1039	36	61-1558	51
57-6082	592	57-7505	594	58-2503	627	59-0650	607	59-1050	620	61-1559	51
57-6085	592	57-7510	221, 599	58-2505	627	59-0651	607	59-1052	620	61-1560	51
57-6086	592	57-7515	221, 599	58-2540	620	59-0652	607	59-1054	620	61-1595	50
57-6087	592	57-7516	221, 599	58-2541	620	59-0653	607	59-1056	620	61-1596	50
57-6088	592	57-7517	221, 599	58-2542	620	59-0654	607	59-1060	621	61-1597	50
57-6150	589	57-7518	221, 599	58-2550	620	59-0655	607	59-1061	621	61-1598	50
57-6151	589	57-7519	221, 598	58-2551	620	59-0656	607	59-1062	620	61-1599	50
57-6152	589	57-7520	599	58-2552	620	59-0659	607	59-1064	621	61-1600	50
57-6160	589	57-7521	599	58-2553	620	59-0760	606	59-1065	621	61-1601	50
57-6161	589	57-7522	599	58-2555	620	59-0761	606	59-1500	627	61-1602	50
57-6163	589	57-7525	594, 622	58-2556	619	59-0762	606	59-2000	627	61-1603	50
57-6164	589	57-7530	595	58-2557	619	59-0763	606	59-2010	627	61-1604	50
57-6165	589	57-7600	565, 597	58-2558	619	59-0764	607	59-2020	626	61-1630	50
57-6171	590	57-7610	597	58-2559	200	59-0765	618	59-2030	626	61-1635	50
57-6172	590	57-7615	565, 596	58-2700	623	59-0770	617	59-2050	626	61-1640	51
57-6173	590	57-7620	596	58-2701	623	59-0771	451	59-2100	77, 624	61-1645	51

SERIES #	PAGE										
61-1646	51	62-4459	603	69-1102	503	77-1105	123	77-1223	123	77-1427	124
61-1647	51	62-4463	600	69-1103	503	77-1106	123	77-1225	123	77-1429	124
61-1648	51	62-4464	604	69-1104	503	77-1107	123	77-1227	123	77-1430	124
61-1649	318	62-4465	604	77-1003	122	77-1108	123	77-1229	123	77-1431	124
61-1655	50, 318	62-4466	605	77-1004	122	77-1109	123	77-1231	123	77-1433	124
61-1660	50	62-4467	604	77-1005	122	77-1110	123	77-1233	123	77-1435	124
61-1700	51	62-4471	601	77-1006	122	77-1111	123	77-1235	123	77-1437	124
61-1710	50, 318	62-4476	604	77-1007	122	77-1112	123	77-1237	123	77-1440	124
61-1740	308	62-4478	605	77-1008	122	77-1113	123	77-1247	123	77-1442	124
61-1741	308	62-4479	601	77-1009	122	77-1114	123	77-1299	123	77-1445	124
61-1742	308	62-4482	600	77-1010	122	77-1115	123	77-1309	127	77-1447	124
61-1743	308	62-4488	601	77-1011	122	77-1116	123	77-1310	127	77-1450	124
61-3000	317	62-4497	604	77-1012	122	77-1117	123	77-1312	127	77-1460	124
61-3010	317	62-4511	603	77-1013	122	77-1118	123	77-1313	127	77-1470	124
61-3020	317	62-4514	603	77-1014	122	77-1119	123	77-1314	127	77-1480	124
61-3030	317	62-4531	600	77-1015	122	77-1120	123	77-1315	127	77-1497	124
61-9424	501	62-4540	602	77-1016	122	77-1121	123	77-1316	127	77-1498	124
62-0040	319	62-4541	602	77-1017	122	77-1122	123	77-1317	127	77-1499	124
62-0044	319	62-4542	602	77-1018	122	77-1123	123	77-1318	127	77-1506	124
62-1240	318	62-4543	602	77-1019	122	77-1124	123	77-1319	127	77-1507	124
62-1241	318	62-4544	602	77-1020	122	77-1125	123	77-1320	127	77-1508	124
62-1242	318	62-4545	602	77-1021	122	77-1127	123	77-1322	127	77-1509	124
62-1243	318	62-4546	602	77-1022	122	77-1129	123	77-1323	127	77-1510	124
62-1244	318	62-4590	600	77-1023	122	77-1130	123	77-1325	127	77-1512	124
62-1245	318	62-4605	605	77-1024	122	77-1131	123	77-1327	127	77-1514	124
62-1246	318	62-4608	605	77-1025	122	77-1133	123	77-1330	127	77-1515	124
62-1247	318	62-4620	600	77-1026	122	77-1135	123	77-1331	127	77-1516	124
62-1248	318	62-5100	605	77-1027	122	77-1137	123	77-1335	127	77-1518	124
62-4387	603	64-4000	612	77-1028	122	77-1140	123	77-1340	127	77-1521	124
62-4388	600	64-4010	223	77-1029	122	77-1142	123	77-1350	127	77-1523	124
62-4389	602	64-4076	613	77-1030	122	77-1145	123	77-1370	127	77-1525	124
62-4391	602	64-4077	612	77-1031	122	77-1147	123	77-1380	127	77-1527	124
62-4393	603	64-4078	612	77-1033	122	77-1150	123	77-1390	127	77-1529	124
62-4395	602	64-4079	612	77-1035	122	77-1197	123	77-1398	127	77-1531	124
62-4397	603	64-4080	612	77-1037	122	77-1198	123	77-1409	124	77-1533	124
62-4421	602	64-4085	626	77-1040	122	77-1199	123	77-1410	124	77-1535	124
62-4422	602	64-5000	616	77-1042	122	77-1209	123	77-1412	124	77-1537	124
62-4423	602	64-5003	616	77-1045	122	77-1210	123	77-1413	124	77-1540	124
62-4427	602	64-5004	616	77-1047	122	77-1211	123	77-1414	124	77-1542	124
62-4432	601	64-5008	615	77-1050	122	77-1212	123	77-1415	124	77-1545	124
62-4433	601	64-5009	615	77-1055	122	77-1213	123	77-1416	124	77-1547	124
62-4434	600	64-5010	616	77-1060	122	77-1214	123	77-1417	124	77-1550	124
62-4438	600	64-5100	619	77-1065	122	77-1215	123	77-1418	124	77-1560	124
62-4440	601	64-5102	613	77-1070	122	77-1216	123	77-1419	124	77-1608	125
62-4442	6										

# Series Index

SERIES #	PAGE								
77-1621	125	77-2121	128	77-2812	131	77-3108	131	77-5908	130
77-1622	125	77-2123	128	77-2813	131	77-3109	131	77-5910	130
77-1623	125	77-2125	128	77-2814	131	77-3110	131	77-5912	130
77-1625	125	77-2127	128	77-2815	131	77-3111	131	77-5914	130
77-1630	125	77-2140	128	77-2816	131	77-3112	131	77-5916	130
77-1631	125	77-2206	128	77-2817	131	77-3113	131	77-5918	130
77-1640	125	77-2207	128	77-2818	131	77-3114	131	77-6205	234
77-1706	127	77-2208	128	77-2819	131	77-3115	131	77-6206	234
77-1707	127	77-2209	128	77-2820	131	77-3116	131	77-6207	234
77-1708	127	77-2210	128	77-2821	131	77-3117	131	77-6208	234
77-1709	127	77-2211	128	77-2823	131	77-3118	131	77-6209	234
77-1710	127	77-2212	128	77-2825	131	77-3121	131	77-6210	234
77-1712	127	77-2213	128	77-2827	131	77-3123	131	77-6211	234
77-1714	127	77-2214	128	77-2829	131	77-4118	131	77-6212	234
77-1716	127	77-2215	128	77-2830	131	77-4123	131	77-6213	234
77-1718	127	77-2216	128	77-2835	131	77-4131	131	77-6214	234
77-1721	127	77-2218	128	77-2840	131	77-4151	131	77-6215	234
77-1723	127	77-2221	128	77-2845	131	77-5103	128	77-6216	234
77-1725	127	77-2223	128	77-2850	131	77-5104	128	77-6217	234
77-1728	127	77-2225	128	77-2900	97	77-5105	128	77-6218	234
77-1740	127	77-2240	128	77-2901	97	77-5106	128	77-6219	234
77-1806	126	77-2310	125	77-2902	97	77-5107	128	77-6220	234
77-1807	126	77-2312	125	77-2903	97	77-5108	128	77-6221	234
77-1808	126	77-2506	233	77-2904	97	77-5109	128	77-6223	234
77-1809	126	77-2507	233	77-2905	97	77-5110	128	77-6409	129
77-1810	126	77-2508	234	77-2906	97	77-5111	128	77-6412	129
77-1812	126	77-2509	234	77-2907	97	77-5112	128	77-6509	130
77-1814	126	77-2512	234	77-2908	97	77-5113	128	77-6510	130
77-1816	126	77-2605	234	77-2909	97	77-5114	128	77-6512	130
77-1818	126	77-2606	234	77-2910	97	77-5115	128	77-6516	130
77-1821	126	77-2607	234	77-2911	97	77-5116	128	77-6521	130
77-1823	126	77-2608	234	77-2912	97	77-5117	128	77-6709	129
77-1825	126	77-2609	234	77-2913	97	77-5118	128	77-6710	129
77-1827	126	77-2610	234	77-2914	97	77-5119	128	77-6712	129
77-1829	126	77-2611	234	77-2915	97	77-5120	128	77-6714	129
77-1840	126	77-2612	234	77-2916	97	77-5121	128	77-6810	129
77-1915	126	77-2613	234	77-2917	97	77-5122	128	77-6812	129
77-1920	126	77-2614	234	77-2918	97	77-5123	128	77-6816	129
77-2023	127	77-2615	234	77-2919	97	77-5308	128	77-6909	130
77-2029	127	77-2616	234	77-2920	97	77-5309	128	77-6910	130
77-2035	127	77-2617	234	77-2921	97	77-5310	128	80-0004	316
77-2040	127	77-2618	234	77-2922	97	77-5409	129, 130	80-0005	316
77-2106	128	77-2620	234	77-2930	97	77-5410	130	90-0000	48
77-2107	128	77-2621	234	77-2931	97	77-5412	129, 103	90-0100	48
77-2108	128	77-2622	234	77-2940	97	77-5414	130	90-0200	48
77-2109	128	77-2623	234	77-3008	131	77-5416	130	90-0300	48
77-2110	128	77-2699	234	77-3010	131	77-5421	130	90-1000	49
77-2112	128	77-2808	131	77-3012	131	77-5510	129		
77-2114	128	77-2809	131	77-3014	131	77-5512	129		
77-2116	128	77-2810	131	77-3016	131	77-5516	129		
77-2118	128	77-2811	131	77-3018	131	77-5709	129		





**S** STULLER

Stuller.com | 800 877 7777